

**PHILIPS**

Data handbook



Electronic  
components  
and materials

**Integrated circuits**

**Book IC18**

**1987**

**Microprocessors and peripherals**

**Elcoma** – Philips Electronic Components and Materials Division – embraces a world-wide group of companies operating under the following names:

**IBRAPE**



Miniwatt

Signetics

**Mullard**

**VALVO**

**PHILIPS**

Elcoma offers you a technological partnership in developing your systems to the full. A partnership to which we can bring

- world-wide production and marketing
- know-how
- systems approach
- continuity
- broad product line
- fundamental research
- leading technologies
- applications support
- quality



## MICROPROCESSORS AND PERIPHERALS

Contents .....	xi
Ordering information .....	xiii
Product status and definitions .....	xiv
<b>Section1 – Quality and Reliability</b>	
Quality and Reliability .....	1.3
<b>Section 2 – Microprocessor Products</b>	
Index .....	2.1
<b>Section 3 – Microcontroller Products</b>	
Not included in this book; for data see book “Microcontrollers and peripherals”	
<b>Section 4 – Package outlines</b>	
Index .....	4.1
<b>Section 5 – Alphanumeric Index</b>	
Alphanumeric Index .....	5.3

Signetics reserves the right to make changes, without notice, in the products, including circuits, standard cells, and/or software, described or contained herein in order to improve design and/or performance. Signetics assumes no responsibility or liability for the use of any of these products, conveys no license or title under any patent, copyright, or mask work right to these products, and makes no representations or warranties that these products are free from patent, copyright, or mask work right infringement, unless otherwise specified. Applications that are described herein for any of these products are for illustrative purposes only. Signetics makes no representation or warranty that such applications will be suitable for the specified use without further testing or modification.

#### LIFE SUPPORT APPLICATIONS

Signetics' Products are not designed for use in life support appliances, devices, or systems where malfunction of a Signetics Product can reasonably be expected to result in a personal injury. Signetics' customers using or selling Signetics' Products for use in such applications do so at their own risk and agree to fully indemnify Signetics for any damages resulting in such improper use or sale.

Signetics registers eligible circuits under  
the Semiconductor Chip Protection Act.

© Copyright 1987 Signetics Corporation

All rights reserved.

## **GENERAL CONTENTS**

**Contents**

**Ordering information**

**Product status definitions**



# Contents

## Microprocessor Products

Ordering Information .....	vii
Product Status .....	viii
<b>Section 1 – QUALITY AND RELIABILITY</b>	
Quality and Reliability .....	1-3
<b>Section 2 – MICROPROCESSOR PRODUCTS</b>	
SCN2641 Asynchronous Communications Interface .....	2-3
SCN2651 Programmable Communications Interface (PCI) .....	2-16
SCN2652/68652 Multi-Protocol Communications Controller (MPCC) .....	2-32
SCN2653/68653 Polynomial Generator Checker (PGC) .....	2-52
SCN2661/68661 Enhanced Programmable Communications Interface (EPCI) .....	2-70
SCN2671 Programmable Keyboard and Communication Controller (PKCC) .....	2-87
SCN2672 Programmable Video Timing Controller (PVTC) .....	2-109
SCB2673 Video Attributes Controller (VAC) .....	2-132
SCN2674 Advanced Video Display Controller (AVDC) .....	2-145
SCB2675 Color/Monochrome Attributes Controller (CMAC) .....	2-177
SCB2675T Turbo Color/Monochrome Attributes Controller (Turbo-CMAC) .....	2-188
SCB2677 Video Attributes Controller (VAC) .....	2-199
SCN2681 Dual Asynchronous Receiver/Transmitter (DUART) .....	2-211
SCC2691 Universal Asynchronous Receiver/Transmitter (UART) .....	2-230
SCC2692 Dual Asynchronous Receiver/Transmitter (DUART) .....	2-247
SCC2698 Octal Universal Asynchronous Receiver/Transmitter (Octal UART) .....	2-266
SCC63484 Advanced CRT Controller (ACRTC) .....	2-285
SCN68000 16-/32-Bit Microprocessor .....	2-340
SCN68010 16-Bit Virtual Memory Microprocessor .....	2-402
SCB68154 Interrupt Generator .....	2-471
SCB68155 Interrupt Handler .....	2-482
SCB68171 Very Little Serial Interface Chip (VLSIC) .....	2-499
SCB68172 VMEbus Controller (BUSCON) .....	2-504
SCC68173 VMSbus Controller (VMSCON) .....	2-530
SCB68430 Direct Memory Access Interface (DMAI) .....	2-544
SCN68562 Dual Universal Serial Communications Controller (DUSCC) .....	2-565
SCN68681 Dual Asynchronous Receiver/Transmitter (DUART) .....	2-612
SCC68692 Dual Asynchronous Receiver/Transmitter (DUART) .....	2-632
<b>Section 4 – PACKAGE OUTLINES</b>	
A Plastic Leaded Chip Carrier .....	4-3
D Plastic Small Outline .....	4-6
F Hermetic CERDIP .....	4-8
I Hermetic SDIP .....	4-9
N Plastic DIP .....	4-13
P Grid Array .....	4-18
<b>Section 5 – ALPHANUMERIC INDEX</b>	
Alphanumeric Index .....	5-3



# Ordering Information

## Microprocessor Products

### PART NUMBERING SYSTEM

Example:

**S C N 6 8 4 5 4 C 6 N 4 8**

Microprocessor Division Identifier - Always SC

Process/Power Variation  
 N = N - Channel  
 C = C - MOS\*  
 B = Bipolar

Basic Part Number  
 See individual data sheets.

Pin Count  
 14, 16, 20, 24, 28, 40, 48, etc.

Package  
 I = Ceramic    A = PLCC  
 N = Plastic    P = PGA  
 F = Cerdip

Temperature	Timing Variation					
	Spd	Sym	Spd	Sym	Spd	Sym
01	1	21	1	41	1	
02	2	22	2	42	2	
03	3	23	3	43	3	
04	4	24	4	44	4	
05	5	25	5	45	5	
06	6	26	6	46	6	
07	7	27	7	47	7	
08	8	28	8	48	8	
09	9	29	9	49	9	
10	A	30	0	50	0	
11	B	31	1	51	1	
12	C	32	2	52	2	
13	D	33	3	53	3	
14	E	34	4	54	4	
15	F	35	5	55	5	
16	6	36	6	56	6	
17	7	37	7	57	7	
18	8	38	8	58	8	
19	9	39	9			
20	0	40	0			

Unless otherwise noted.

\*CMOS designed may be part of basic part type.

# Product Status

Microprocessor Products

## DEFINITIONS

<b>Data Sheet Identification</b>	<b>Product Status</b>	<b>Definition</b>
<i>Objective Specification</i>	<b>Formative or In Design</b>	This data sheet contains the design target or goal specifications for product development. Specifications may change in any manner without notice.
<i>Preliminary Specification</i>	<b>Preproduction Product</b>	This data sheet contains preliminary data and supplementary data will be published at a later date. Signetics reserves the right to make changes at any time without notice in order to improve design and supply the best possible product.
<i>Product Specification</i>	<b>Full Production</b>	This data sheet contains Final Specifications. Signetics reserves the right to make changes at any time without notice in order to improve design and supply the best possible product.





# Section 1 Quality and Reliability

**Microprocessor Products**



# Quality and Reliability

## Microprocessor Products

### INTRODUCTION

The Microprocessor Division was formed in 1979 when it became apparent that microprocessor circuits and their peripheral devices would become increasingly important system components to the OEM customer base. Because of performance to cost ratios, reduced power requirements and inherent reliability, these components provide the solution to designers' complex system requirements.

NMOS became the dominant technology because of the simplicity of its design and processing and its large historical reliability data base. To date, NMOS has serviced 95% of the division's device requirements. Bipolar devices are used to a limited extent as interface drivers between the NMOS system components and CRT displays.

The Microprocessor Division serves a broad base of customers with its product lines of eight and sixteen bit microprocessors, microcontrollers, and data communication and CRT peripheral circuits. The division's customers range from large mainframe computer manufacturers to small systems users, and the division can generally satisfy all the microprocessor requirements of any customer.

Our goal is to establish ourselves as the preferred alternate source in both the 68000 microprocessor and the 80XX microcontroller product areas and at the same time become the prime supplier of the interface and peripheral circuits required to integrate the parts within a system. Our design philosophy is to give superior performance while minimizing the overall number of parts required for the overall system.

The terms quality and reliability are often misinterpreted. In general, quality refers to the condition of a device when received; reliability covers extent of useful life. Quality is readily measurable; reliability is predictable and verifiable based on historical evidence.

### MICROPROCESSOR DIVISION RELIABILITY

No amount of stress testing can improve a product's reliability. Stress tests are used to measure and define an end of life which can be expected from a family of products. Reliability as well as quality must be built in through proper design, processing, assembly, testing and handling. For Signetics' Microprocessor Division parts, accelerated life test data show an extremely reliable product line and serve as one input for continuous product reliability improvement.

### DESIGN

Product quality and reliability begin in design. Strategic questions directly affecting reliability must be answered. How much static protection is required on input leads? Do formal design rules exist? Can they ever be violated? What method is used to anticipate future processes or "shrinks"?

Within Signetics' Microprocessor Division, rigid guidelines are in effect to ensure compliance with our design rules. Design rules, once established, are inviolate.

### QUALIFICATION TESTING

Signetics' Microprocessor Division verifies device reliability through a series of qualification tests and a continuous reliability monitor program, Sure III (Systematic Uniform Reliability Evaluation).

All new fab processes at Signetics are qualified by stress testing parts from a variety of production lots. This accelerated stress testing is shown in the table.

### SURE III

Continuous reliability monitoring is performed via our SURE III program. Devices are ran-

domly selected from production lots and subjected to the same environmental stresses noted in the table. The program is administered by the Corporate Reliability Engineering Group, which publishes a summary of results on a quarterly basis.

The SURE III program covers two functions: Monitoring short term and long term reliability performance.

### LONG-TERM AUDIT

One hundred devices from each generic family are subjected to each of the following stresses every other four weeks:

- High Temperature Operating Life —  $T_J = 150^\circ\text{C}$ , 1000 hours — (Static Biased or Dynamic Operation, as appropriate);
- Temperature-Humidity Biased Life —  $85^\circ\text{C}$ , 85% RH, 1000 hours, static biased;
- Temperature Cycling (Air-Air) —  $-65^\circ\text{C}$  to  $+150^\circ\text{C}$ , 1000 cycles.

### SHORT-TERM MONITOR

Every week 20-piece samples from each generic family are run to 96 hours of pressure pot (15 psig,  $121^\circ\text{C}$ , 100% saturated steam), 300 cycles of thermal shock ( $-65^\circ\text{C}$  to  $+150^\circ\text{C}$ ) and 168 hours of high temperature operating life ( $T_J = 150^\circ\text{C}$ , static or dynamic operation).

In addition, each Signetics assembly plant performs SURE product monitor stresses weekly on each generic family and molded package, by pin count and frame type. Fifty pieces are subjected to 300 cycles of thermal shock (Cond. C) and 100 devices are subjected to pressure pot stress at 20 psig for 72 hours (168 hour equivalent at 15 psig).

# Quality and Reliability

## Accelerated Life Stress Tests

TEST	TEST CONDITION	NUMBER OF DEVICES	DURATION
DHTL	Dynamic high temperature life	$T_A @ 125^\circ\text{C}$ (operating)	52
SHTL	Static high temperature life	$T_A @ 125^\circ\text{C}$ (operating)	52
THBS	Biased temperature humidity life	$85^\circ\text{C}/85\%$ RH (operating)	52
PPOT	Pressure pot (autoclave)	$121^\circ\text{C}/15$ psig (storage)	52
TMSK	Thermal shock	$-55^\circ\text{C}/125^\circ\text{C}$ liq. to liq. (storage)	77
TMCL	Temperature cycle (air-to-air)	$-65^\circ\text{C}/150^\circ\text{C}$ (storage)	77

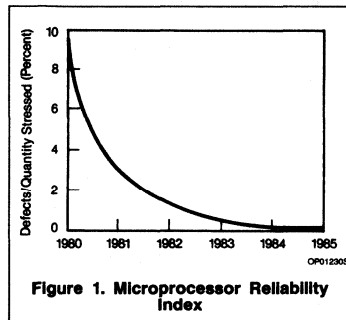

Figure 1 shows the relative improvement in Sure III performance for the Microprocessor Division for the past five years. This curve combines all the stress tests and plots the overall percentage defective by year. Clearly, the reliability of our product line is improving, and more importantly, it is consistent and predictable.

## SIGNETICS' QUALITY IMPROVEMENT PROGRAM

Signetics began its Quality Improvement Program in 1980, and developed it around the concepts outlined in the book, "Quality is Free," by Phil Crosby.

This program, which is actively supported by top management, defines Quality as "Conformance to the Specification." With this definition in mind, our performance standard is "Zero Defects." Tracking charts measuring

quality improvement targets are used and displayed throughout the Division.

Microprocessor Division personnel are all actively involved in this program. Our people have taken formal training in Quality College and have pledged to "Do It Right the First Time, On Time." Administrative personnel promise to "Make Certain" of their own work.

The program improves quality through education, commitment and feedback.

Internally, there are many signs of the program's success. The SURE III Reliability Assurance Monitor shows improved results in each of the past three years. In-line quality improvements are impressive. All new products are placed on QRA Hold until completion of environmental stress testing; all significant process changes go through qualification prior to release to production; test programs are controlled and released only after extensive engineering correlation; wafers with less than the required minimum number of good die are scrapped to avoid jeopardizing product quality.

These are examples of how the Quality Improvement Program functions internally. However, the real measure of the program is customer belief in and acceptance of our improvement.

Over the past few years, customers have verified a continuous improvement in the quality and reliability of Microprocessor Division parts. Figure 2 shows the improvement in visual mechanical and electrical outgoing quality levels over the past several years.

In addition to the marked improvement in our AOQ (Average Outgoing Quality), we have become a qualified source for the 80XX and the 68000 families, as well as our own proprietary peripheral circuits, for more than 200 customers. We have developed Ship-to-Stock programs for several key accounts, eliminating the need for costly incoming inspection by our customers.

The improved reliability of our parts has allowed several customers to drop their requirements for burn-in for high reliability programs. This, of course, has lowered their costs significantly and has allowed them to improve their over-all system reliability.

Reliability testing is an important monitor of our manufacturing process. Signetics' microprocessor parts not only meet specifications when shipped but continue to operate satisfactorily throughout their lifetime.

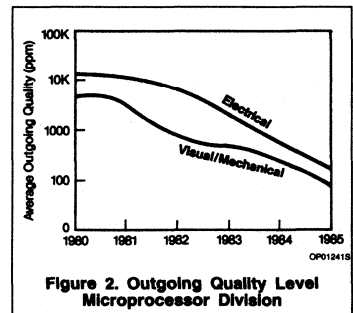

# Section 2

## Microprocessor Products

### INDEX

<b>SCN2641</b>	Asynchronous Communications Interface .....	2-3
<b>SCN2651</b>	Programmable Communications Interface (PCI) .....	2-16
<b>SCN2652/68652</b>	Multi-Protocol Communications Controller (MPCC) .....	2-32
<b>SCN2653/68653</b>	Polynomial Generator Checker (PGC) .....	2-52
<b>SCN2661/68661</b>	Enhanced Programmable Communications Interface (EPCI) .....	2-70
<b>SCN2671</b>	Programmable Keyboard and Communication Controller (PKCC) .....	2-87
<b>SCN2672</b>	Programmable Video Timing Controller (PVTC) .....	2-109
<b>SCB2673</b>	Video Attributes Controller (VAC) .....	2-132
<b>SCN2674</b>	Advanced Video Display Controller (AVDC) .....	2-145
<b>SCB2675</b>	Color/Monochrome Attributes Controller (CMAC) .....	2-177
<b>SCB2675T</b>	Turbo Color/Monochrome Attributes Controller (Turbo-CMAC) .....	2-188
<b>SCB2677</b>	Video Attributes Controller (VAC) .....	2-199
<b>SCN2681</b>	Dual Asynchronous Receiver/Transmitter (DUART) .....	2-211
<b>SCC2691</b>	Universal Asynchronous Receiver/Transmitter (UART) .....	2-230
<b>SCC2692</b>	Dual Asynchronous Receiver/Transmitter (DUART) .....	2-247
<b>SCC2698</b>	Octal Universal Asynchronous Receiver/Transmitter (Octal UART) .....	2-266
<b>SCC63484</b>	Advanced CRT Controller (ACRTC) .....	2-285
<b>SCN68000</b>	16-/32-Bit Microprocessor .....	2-340
<b>SCN68010</b>	16-Bit Virtual Memory Microprocessor .....	2-402
<b>SCB68154</b>	Interrupt Generator .....	2-471
<b>SCB68155</b>	Interrupt Handler .....	2-482
<b>SCB68171</b>	Very Little Serial Interface Chip (VLSIC) .....	2-499
<b>SCB68172</b>	VMEbus Controller (BUSCON) .....	2-504
<b>SCC68173</b>	VMSbus Controller (VMSCON) .....	2-530
<b>SCB68430</b>	Direct Memory Access Interface (DMAI) .....	2-544
<b>SCN68562</b>	Dual Universal Serial Communications Controller (DUSCC) .....	2-565
<b>SCN68681</b>	Dual Asynchronous Receiver/Transmitter (DUART) .....	2-612
<b>SCC68692</b>	Dual Asynchronous Receiver/Transmitter (DUART) .....	2-632



# SCN2641

## Asynchronous Communications Interface

Product Specification

### Microprocessor Products

#### DESCRIPTION

The Signetics SCN2641 is a universal asynchronous data communications controller chip that interfaces directly to most 8-bit microprocessors and may be used in a polled or interrupt-driven system environment. The SCN2641 accepts programmed instructions from the microprocessor while supporting asynchronous serial data communications in full- or half-duplex mode.

The SCN2641 serializes parallel data characters received from the microprocessor for transmission. Simultaneously, it can receive serial data and convert it into parallel data characters for input to the microcomputer.

The SCN2641 contains a baud rate generator which can be programmed to either accept an external clock or to generate internal transmit or receive clocks. Sixteen different baud rates can be selected under program control when operating in the internal clock mode.

The SCN2641 is constructed using Signetics n-channel silicon gate depletion load technology and is packaged in a 24-pin DIP.

#### FEATURES

- 5- to 8-bit characters plus parity
- 1, 1½ or 2 stop bits transmitted
- Odd, even or no parity
- Parity, overrun and framing error detection
- Line break detection and generation
- False start bit detection
- Automatic serial echo mode (echoplex)
- Local or remote maintenance loopback mode
- Baud rate:
  - DC to 1M bps (1X clock)
  - DC to 62.5K bps (16X clock)
  - DC to 15.625K bps (64X clock)
- Internal or external baud rate clock
- 16 internal rates
- Double-buffered transmitter and receiver
- Single +5V power supply
- 400 mil package width

#### APPLICATIONS

- Intelligent terminals
- Network processors
- Front-end processors
- Remote data concentrators
- Serial peripherals

#### PIN CONFIGURATIONS

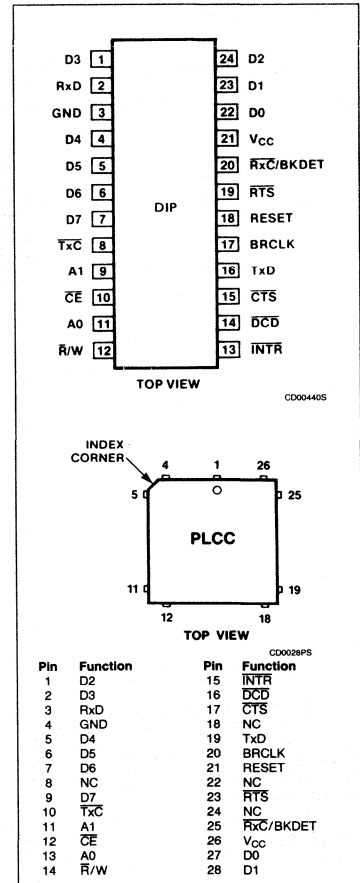

## Asynchronous Communications Interface

SCN2641

## ORDERING INFORMATION

PACKAGES	$V_{CC} = 5V \pm 5\%$ , $T_A = 0^\circ\text{C to } 70^\circ\text{C}$
Plastic DIP	SCN2641CC1N24
Plastic LCC	SCN2641CC1A28

## BLOCK DIAGRAM

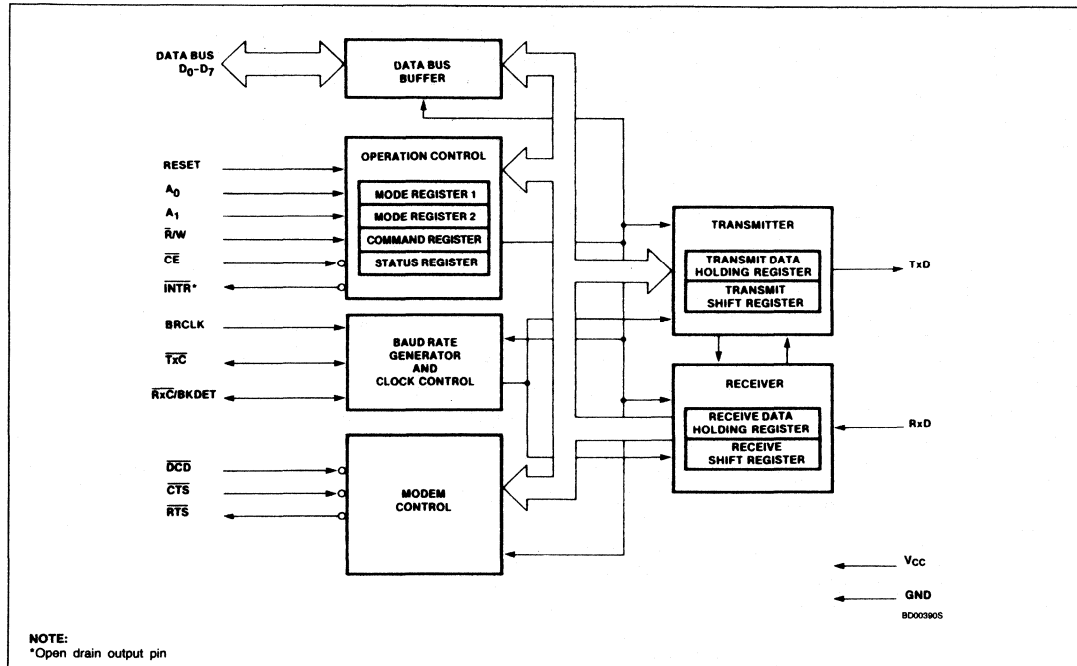

## BLOCK DIAGRAM

The SCN2641 consists of five major sections: the transmitter, receiver, timing, operation control and modem control. These sections communicate with each other via an internal data bus and an internal control bus. The internal data bus interfaces to the microprocessor data bus via a data bus buffer.

## Operation Control

This functional block stores configuration and operation commands from the CPU and generates appropriate signals to various internal sections to control the overall device operation. It contains read and write circuits to permit communications with the microprocessor via the data bus and contains mode registers 1 and 2, the command register, and the status register. Details of register addressing are presented in the SCN2641 programming section of this data sheet.

## Timing

The SCN2641 contains a baud rate generator (BRG) which is programmable to accept external transmit or receive clocks or to divide an external clock to perform data communications. The unit can generate 16 commonly used baud rates, any one of which can be selected for full-duplex operation. See Table 1.

## Receiver

The receiver accepts serial data on the Rx̄D pin, converts this serial input to parallel format, checks for certain errors and sends an "assembled" character to the CPU.

## Transmitter

The transmitter accepts parallel data from the CPU, appends start and stop bits, and, optionally, a parity bit, and outputs a composite serial stream of data on the Tx̄D output pin.

## Modem Control

The modem control section provides interfacing for two input signals and one output signal used for "handshaking" and status indication between the CPU and a modem.

## INTERFACE SIGNALS

The SCN2641 interface signals can be grouped into two types: the CPU-related signals (shown in Table 2), which interface the SCN2641 to the microprocessor system and the device-related signals (shown in Table 3), which are used to interface to the communications device or system.

## OPERATION

The functional operation of the SCN2641 is programmed by a set of control words supplied by the CPU. These control words speci-



## Asynchronous Communications Interface

## SCN2641

Table 1. Baud Rate Generator Characteristics (BRCLK = 3.6864MHz)

MR23 - 20	BAUD RATE	ACTUAL FREQUENCY 16X CLOCK	PERCENT ERROR	DIVISOR
0000	50	0.8kHz	—	4608
0001	75	1.2	—	3072
0010	110	1.7596	-0.022	2095
0011	134.5	2.152	—	1713
0100	150	2.4	—	1536
0101	300	4.8	—	768
0110	600	9.6	—	384
0111	1200	19.2	—	192
1000	1800	28.8	—	128
1001	2000	32.055	0.174	115
1010	2400	38.4	—	96
1011	3600	57.6	—	64
1100	4800	76.8	—	48
1101	7200	115.2	—	32
1110	9600	153.6	—	24
1111	19200	307.2	—	12

fy items such as baud rate, number of bits per character, etc. The programming procedure is described in the SCN2641 programming section of this data sheet.

After programming, the SCN2641 is ready to perform the desired communications functions. The receiver performs serial to parallel conversion of data received from a modem or equivalent device. The transmitter converts parallel data received from the CPU to a serial bit stream. These actions are accomplished within the framework specified by the control words.

### Receiver

The SCN2641 is conditioned to receive data when the  $\overline{\text{DCD}}$  input is low and the  $\text{RxEN}$  bit in the command register is true. The receiver looks for a high-to-low transition of the start bit on the  $\text{RxD}$  input line. If a transition is detected, the state of the  $\text{RxD}$  line is sampled again after a delay of one-half of a bit time. If  $\text{RxD}$  is now high, the search for a valid start bit is begun again. If  $\text{RxD}$  is still low, a valid start bit is assumed and the receiver continues to sample the input line at one bit time intervals until the proper number of data bits, the parity bit, and one stop bit have been assembled. The data is then transferred to the receive data holding register, the  $\text{RxRDY}$

bit in the status register is set, and the  $\overline{\text{INTR}}$  output is asserted. If the character length is less than 8 bits, the high-order unused bits in the holding register are set to zero. The parity error, framing error, and overrun error status bits are strobed into the status register on the positive-going edge of  $\text{RxC}$  corresponding to the received character boundary. If the stop bit is present, the receiver will immediately begin its search for the next start bit. If the stop bit is absent (framing error), the receiver will interpret a space as a start bit if it persists into the next bit time interval. If a break condition is detected ( $\text{RxD}$  is low for the entire character as well as the stop bit), only one character consisting of all zeros (with the  $\text{FE}$  status bit set) will be transferred to the holding register. The  $\text{RxD}$  input must return to a high condition before a search for the next start bit begins.

Pin 20 can be programmed to be a break detect output by appropriate setting of  $\text{MR27} - \text{MR24}$ . If so, a detected break will cause that pin to go high. When  $\text{RxD}$  returns to mark for one  $\text{RxC}$  time, pin 20 will go low. Refer to the break detection timing diagram.

### Transmitter

The SCN2641 is conditioned to transmit data when the  $\text{CTS}$  input is low and the  $\text{TxEN}$

command register bit is set. The SCN2641 indicates to the CPU that it can accept a character for transmission by setting the  $\text{TxRDY}$  status bit and asserting the  $\overline{\text{INTR}}$  output. When the CPU writes a character into the transmit data holding register, these conditions are negated. Data is transferred from the holding register to the transmit shift register when it is idle or has completed transmission of the previous character. The  $\text{TxRDY}$  conditions are then asserted again. Thus, one full character time of buffering is provided.

The transmitter automatically sends a start bit followed by the programmed number of data bits, the least significant bit being sent first. It then appends an optional odd or even parity bit and the programmed number of stop bits. If, following transmission of the data bits, a new character is not available in the transmit holding register, the  $\text{TxD}$  output remains in the marking (high) condition and the  $\text{TxEMT}/\text{DSCHG}$  status bit and the  $\overline{\text{INTR}}$  output are asserted. Transmission resumes when the CPU loads a new character into the holding register. The transmitter can be forced to output a continuous low (BREAK) condition by setting the send break command bit ( $\text{CR3}$ ) high.

## Asynchronous Communications Interface

SCN2641

Table 2. CPU-Related Signals

PIN NAME	PIN NO.		INPUT/OUTPUT	FUNCTION
	DIP	PLCC		
V <sub>CC</sub>	21	26	I	+5V supply input
GND	3	4	I	Ground
RESET	18	21	I	A high on this input performs a master reset on the SCN2641. This signal asynchronously terminates any device activity and clears the mode, command and status registers. The device assumes the idle state and remains there until initialized with appropriate control words.
A <sub>1</sub> - A <sub>0</sub>	9, 11	11, 13	I	Address lines used to select internal SCN2641 registers.
$\bar{R}/W$	12	14	I	Read command when low, write command when high.
$\bar{CE}$	10	12	I	Chip enable command. When low, indicates that control and data lines to the SCN2641 are valid and that the operation specified by the $\bar{R}/W$ , A <sub>1</sub> and A <sub>0</sub> inputs should be performed. When high, places the D <sub>0</sub> - D <sub>7</sub> lines in the 3-State condition.
D <sub>7</sub> - D <sub>0</sub>	7-4,1, 24-22	9,7-5, 2,1, 28,27	I/O	8-bit, 3-State data bus used to transfer commands, data and status between the SCN2641 and the CPU. D <sub>0</sub> is the least significant bit; D <sub>7</sub> the most significant bit.
INTR	13	15	O	Interrupt request output (open drain). This output is asserted (low) under the following conditions. 1. When the transmitter holding register (THR) is ready to accept a data character from the CPU. This corresponds to assertion of status bit SR0. If this is the only condition asserting the output, the output will be negated (high) when the THR is loaded by the CPU, or if the transmitter is disabled via command register bit CR0. 2. When the receiver holding register (RHR) has a character ready to be read by the CPU. This corresponds to assertion of status bit SR1. If this is the only condition asserting the output, the output will be negated (high) when the RHR is read by the CPU, or if the receiver is disabled via command register bit CR2. 3. When the transmitter has completed serialization of the last character loaded by the CPU. This corresponds to assertion of status bit SR2. If this is the only condition asserting the output, the output will be negated (high) when the THR is loaded by the CPU. 4. When a change of state has occurred at the DCD input while either the receiver or the transmitter are enabled. This corresponds to assertion of status bit SR2. If this is the only condition asserting the output, the output will be negated (high) when the status register is read by the CPU.

**PROGRAMMING**

Prior to initiating data communications, the SCN2641 operational mode must be programmed by performing write operations to the mode and command registers. The SCN2641 can be reconfigured at any time during program execution. A flowchart of the initialization process appears in Figure 1.

The internal registers of the SCN2641 are accessed by applying specific signals to the  $\bar{CE}$ ,  $\bar{R}/W$ , A<sub>1</sub> and A<sub>0</sub> inputs. The conditions

necessary to address each register are shown in Table 4.

Reading or loading the mode registers is done as follows: the first write (or read) operation addresses mode register 1 and a subsequent operation addresses mode register 2. If more than the required number of accesses are made, the internal sequencer recycles to point at the first register. The pointer is reset to mode register 1 by a RESET input or by performing a read com-

mand register operation, but is unaffected by any other read or write operation.

The SCN2641 register formats are summarized in Tables 5, 6, 7 and 8. Mode registers 1 and 2 define the general operational characteristics of the SCN2641, while the command register controls the operation within this basic framework. The SCN2641 indicates its status in the status register. These registers are cleared when a RESET input is applied.

**Mode Register 1 (MR1)**

Table 5 illustrates mode register 1. Bits MR11 and MR10 select the baud rate multiplier. 1X, 16X and 64X multipliers are programmable if the external clock input option is selected by MR24 or MR25.

MR13 and MR12 select a character length of 5, 6, 7 or 8 bits. The character length does not include the parity bit (if programmed), and does not include the start and stop bits.

MR14 controls parity generation. If enabled, a parity bit is added to the transmitted character and the receiver performs a parity check on incoming data. MR15 selects odd or even parity when parity is enabled by MR14.

MR17 and MR16 select character framing of 1, 1.5 or 2 stop bits (If 1X baud rate is

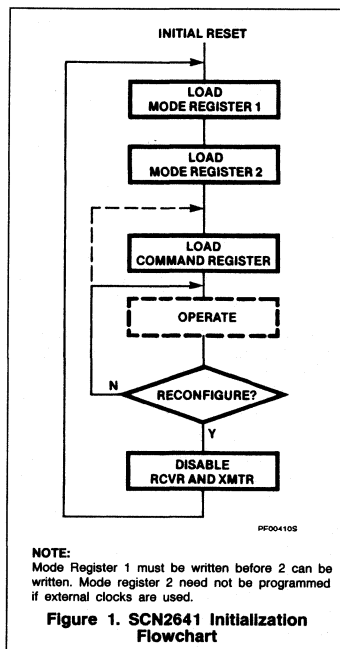
## Asynchronous Communications Interface

SCN2641

programmed, 1.5 stop bits default to 1 stop bit on transmit).

The bits in the mode register affecting character assembly and disassembly (MR12 – MR16) can be changed dynamically (during active receive/transmit operation). The character mode register affects both the transmitter and receiver; therefore, character changes should be made when RxEN and TxEN = 0 or when TxEN = 1 and the transmitter is marking in half-duplex mode (RxEN = 0).

To effect assembly/disassembly of the next received/transmitted character, MR12 – MR15 must be changed within n-bit times of the assertion of RxRDY/TxRDY. (n = smaller of the new and old character lengths.)

### Mode Register 2 (MR2)

Table 6 illustrates mode register 2. MR23, MR22, MR21 and MR20 control the frequency of the internal baud rate generator (BRG). Sixteen rates are selectable as per Table 1. MR23 – MR20 are don't cares if external clocks are selected (MR25 – MR24 = 0). The individual rates are given in Table 1.

MR24 – MR27 select the receive and transmit clock source (either the BRG or an external input) and the function at pins 8 and 20 (Refer to Table 6).

### Command Register (CR)

Table 7 illustrates the command register. Bits CR0 (TxEN) and CR2 (RxEN) enable or disable the transmitter and receiver respectively. If the transmitter is disabled, it will complete the transmission of the character in the transmit shift register (if any) prior to terminating operation. The TxD output will then remain in the marking state (high), while the TxRDY and TxEMT status bits go low. Disabling the receiver causes the RxRDY status bit to go low. If the receiver is disabled, it will terminate operation immediately. Any character being assembled will be negated. A 0-to-1 transition of CR2 will initiate start bit search on the second Rx $\overline{C}$  rising edge following the transition.

Bit CR5 (RTS) controls the RTS output. Data at the output is the logical complement of the register data.

Setting CR3 will force and hold the TxD output low (spacing condition) at the end of the current transmitted character. Normal operation resumes when CR3 is cleared. The user should wait at least one bit time after terminating the break before loading the THR with the next character to be transmitted.

Setting CR4 causes the error flags in the status register (SR3, SR4 and SR5) to be cleared. This is a one-time command. There is no internal latch for this bit.

**Table 3. Device-Related Signals**

PIN NAME	DIP	PLCC	INPUT/OUTPUT	FUNCTION
BRCLK	17	20	I	Clock input to the internal baud rate generator (see Table 1). Not required if external receiver and transmitter clocks are used.
$\overline{RxC}/$ BKDET	20	25	I/O	Receiver clock. If external receiver clock is programmed, this input controls the rate at which the character is to be received. Its frequency is 1X, 16X or 64X the baud rate, as programmed by mode register 1. Data are sampled on the rising edge of the clock. If internal receiver clock is programmed, this pin can be a 1X/16X clock or a break detect output pin.
RxD	2	3	I	Serial data input to the receiver. "Mark" is high, "space" is low.
$\overline{TxC}$	8	10	I/O	Transmitter clock. If external transmitter clock is programmed, this input controls the rate at which the character is transmitted. Its frequency is 1X, 16X or 64X the baud rate, as programmed by mode register 1. The transmitted data changes on the falling edge of the clock. If internal transmitter clock is programmed, this pin can be a 1X/16X clock output.
TxD	16	19	O	Serial data output from the transmitter. "Mark" is high, "space" is low. Held in mark condition when the transmitter is disabled.
$\overline{DCD}$	14	16	I	Data carrier detect input. Must be low in order for the receiver to operate. Its complement appears as status register bit SR6. Causes a low output on INTR when its state changes if CR2 or CR0 = 1. If DCD goes high while receiving, the Rx $\overline{C}$ is internally inhibited. Operation of the receiver resumes on the second $\overline{RxC}$ rising edge following assertion of DCD.
$\overline{CTS}$	15	17	I	Clear to send input. Must be low in order for the transmitter to operate. If it goes high during transmission, the character in the transmit shift register will be transmitted before termination.
$\overline{RTS}$	19	23	O	General-purpose output which is the complement of command register bit CR5. Normally used to indicate request to send. See Command Register (CR5) for details.

**Table 4. Register Addressing**

$\overline{CE}$	A <sub>1</sub>	A <sub>0</sub>	$\overline{R}/W$	FUNCTION
1	X	X	X	3-State data bus
0	0	0	0	Read receive holding register
0	0	0	1	Write transmit holding register
0	0	1	0	Read status register
0	0	1	1	Invalid
0	1	0	0	Read mode registers 1/2
0	1	0	1	Write mode registers 1/2
0	1	1	0	Read command register
0	1	1	1	Write command register

**NOTE:**  
See AC characteristics section for timing requirements.

## Asynchronous Communications Interface

## SCN2641

When CR5 (RTS) is set, the RTS pin is forced low. A 1-to-0 transition of CR5 will cause  $\overline{\text{RTS}}$  to go high (inactive) one TxC time after the last serial bit has been transmitted. If a 1-to-0 transition of CR5 occurs while data is being transmitted,  $\overline{\text{RTS}}$  will remain low (active) until both the THR and the transmit shift register are empty and then go high one TxC time later.

The SCN2641 can operate in one of four submodes. The operational submode is determined by CR7 and CR6. CR7 – CR6 = 00 is the normal mode, with the transmitter and receiver operating independently in accordance with the mode and status register instructions.

CR7 – CR6 = 01 places the SCN2641 in the automatic echo mode. Clocked, regenerated received data are automatically directed to the TxD line while normal receiver operation continues. The receiver must be enabled (CR2 = 1), but the transmitter need not be enabled. CPU-to-receiver communications continue normally, but the CPU-to-transmitter link is disabled. Only the first character of a break condition is echoed. The TxD output will go high until the next valid start is detected. The following conditions are true while in automatic echo mode:

1. Data assembled by the receiver are automatically placed in the transmit holding register and retransmitted by the transmitter on the TxD output.
2. The transmitter is clocked by the receive clock.

3. The  $\overline{\text{INTR}}$  pin will reflect only the data set change condition.
4. The TxEN command (CR0) is ignored.

Two diagnostic submodes can also be configured. In local loopback mode (CR7 – CR6 = 10), the following loops are connected internally:

1. The transmitter output is connected to the receiver input.
2.  $\overline{\text{RTS}}$  is connected to  $\overline{\text{CTS}}$ .
3. The receiver is clocked by the transmitter clock.
4. The  $\overline{\text{RTS}}$  and TxD outputs are held high.
5. The  $\overline{\text{CTS}}$ ,  $\overline{\text{DCD}}$  and RxD inputs are ignored.

Additional requirements to operate in the local loopback mode are that CR0 (TxEN), CR1 and CR5 (RTS) must be set to 1. CR2 (RxEN) is ignored by the SCN2641.

The second diagnostic mode is the remote loopback mode (CR7 – CR6 = 11). In this mode:

1. Data assembled by the receiver are automatically placed in the transmit holding register and retransmitted by the transmitter on the TxD output.
2. The transmitter is clocked by the receive clock.
3. No data is sent to the local CPU, but the error status conditions (PE, OE, FE) are set.
4. The  $\overline{\text{INTR}}$  output is held high.

5. CR0 (TxEN) is ignored.
6. All other signals operate normally.

**Status Register**

The data contained in the status register (as shown in Table 8) indicate receiver and transmitter conditions and modem/data set status.

SR0 is the transmitter ready (TxRDY) status bit. It is valid only when the transmitter is enabled. If equal to 0, it indicates that the transmit holding register has been loaded by the CPU and the data has not been transferred to the transmit shift register. If set equal to 1, it indicates that the holding register is ready to accept data from the CPU. This bit is initially set when the transmitter is enabled by CR0, unless a character has previously been loaded into the holding register. It is not set when the automatic echo or remote loopback modes are programmed. When this bit is set, the  $\overline{\text{INTR}}$  output pin is low, except in the automatic echo and remote loopback modes.

SR1, the receiver ready (RxRDY) status bit, indicates the condition of the receive data holding register. If set, it indicates that a character has been loaded into the holding register from the receive shift register and is ready to be read by the CPU. If equal to 0, there is no new character in the holding register. This bit is cleared when the CPU reads the receive data holding register or when the receiver is disabled by CR2. When set, the  $\overline{\text{INTR}}$  output is low.

**Table 5. Mode Register 1 (MR1)**

MR17	MR16	MR15	MR14	MR13	MR12	MR11	MR10
Stop Bit Length		Parity Type	Parity Control	Character Length		Mode and Baud Rate Factor	
00 = Invalid 01 = 1 stop bit 10 = 1½ stop bits 11 = 2 stop bits		0 = Odd 1 = Even	0 = Disabled 1 = Enabled	00 = 5 bits 01 = 6 bits 10 = 7 bits 11 = 8 bits		00 = Invalid 01 = 1X rate 10 = 16X rate 11 = 64X rate	

**NOTE:**

Baud rate factor applies only if external clock is selected. Factor is 16X if internal clock is selected.

**Table 6. Mode Register 2 (MR2)**

MR27 – MR24								MR23 – MR20	
TxC	RxC	Pin 8	Pin 20	TxC	RxC	Pin 8	Pin 20	Baud Rate Selection	
0000	E	E	TxC	RxC	1000	E	E	NF	RxC/TxC
0001	E	I	TxC	1X	1001	E	I	TxC	BKDET
0010	I	E	1X	RxC	1010	I	E	NF	RxC
0011	I	I	1X	1X	1011	I	I	1X	BKDET
0100	E	E	TxC	RxC	1100	E	E	NF	RxC/TxC
0101	E	I	TxC	16X	1101	E	I	TxC	BKDET
0110	I	E	16X	RxC	1110	I	E	NF	RxC
0111	I	I	16X	16X	1111	I	I	16X	BKDET

**NOTES:**

E = External clock      NF = No function; output not valid  
I = Internal clock (BRG)      1X and 16X are clock outputs

## Asynchronous Communications Interface

SCN2641

Table 7. Command Register (CR)

CR7	CR6	CR5	CR4	CR3	CR2	CR1	CR0
Operating Mode		Request To Send	Reset Error	Force Break	Receive Control (RxEN)		Transmit Control (TxEN)
00 = Normal operation 01 = Automatic echo mode 10 = Local loopback 11 = Remote loopback		0 = Force RTS output high after TxSR serialization 1 = Force RTS output low	0 = Normal 1 = Reset error flags in status register (FE, OE, PE)	0 = Normal 1 = Force break	0 = Disable 1 = Enable	Not used. Must be programmed to '1'	0 = Disable 1 = Enable

Table 8. Status Register (SR)

SR7	SR6	SR5	SR4	SR3	SR2	SR1	SR0
	Data Carrier Detect	Framing Error	Overrun Error	Parity Error	TxE <sub>MT</sub> /D <sub>S</sub> CHG	RxRDY	TxRDY
Not used	0 = DCD input is high 1 = DCD input is low	0 = Normal 1 = Framing Error	0 = Normal 1 = Overrun Error	0 = Normal 1 = Parity error	0 = Normal 1 = Change in DCD or transmit shift register is empty	0 = Receive holding register empty 1 = Receive holding register has data	0 = Transmit holding register busy 1 = Transmit holding register empty

The TxEMT/DSCHG bit, SR2, when set, indicates either a change of state of the DCD input (when CR2 or CR0 = 1) or that the transmit shift register has completed transmission of a character and no new character has been loaded into the transmit data holding register. TxEMT will not go active until at least one character has been transmitted. It is cleared by loading the transmit data holding register. The DSCHG condition is enabled when the TxEN = 1 or RxEN = 1. It is cleared when the status register is read by the CPU. If the status register is read twice and SR2 = 1

while SR6 remains unchanged, then a TxEMT condition exists. When SR2 is set, the INTR output is low.

SR3, when set, indicates a received parity error when parity is enabled by MR14. This bit is cleared when the receiver is disabled and by a reset error command, CR4.

The overrun error status bit, SR4, indicates that the previous character loaded into the receive holding register was not read by the CPU at the time a new received character was transferred into it. This bit is cleared

when the receiver is disabled and by the reset error command, CR4.

Bit SR5 signifies that the received character was not framed by a stop bit; i.e., only the first stop bit is checked. If RHR = 0 when SR5 = 1, a break condition is present. The bit is reset when the receiver is disabled and when the reset error command is given.

SR6 reflects the condition of the DCD input. A low input sets the status bit and a high input clears it.

## Asynchronous Communications Interface

SCN2641

ABSOLUTE MAXIMUM RATINGS<sup>1</sup>

SYMBOL	PARAMETER	RATING	UNIT
T <sub>A</sub>	Operating ambient temperature <sup>2</sup> range	0 to +70	°C
T <sub>STG</sub>	Storage temperature range	-65 to +150	°C
	All voltages with respect to ground <sup>3</sup>	-0.5 to +6.0	V

DC ELECTRICAL CHARACTERISTICS<sup>4, 5, 6</sup>

SYMBOL	PARAMETER	TEST CONDITIONS	LIMITS			UNIT
			Min	Typ	Max	
<b>Input voltage</b>						
V <sub>IL</sub> V <sub>IH</sub>	Low High		2		0.8	V
<b>Output voltage</b>						
V <sub>OL</sub> V <sub>OH</sub> <sup>7</sup>	Low High	I <sub>OL</sub> = 2.2mA I <sub>OH</sub> = -400μA	2.4		0.4	V
I <sub>IL</sub>	Input leakage current	V <sub>IN</sub> = 0 to V <sub>CC</sub>			10	μA
<b>3-State output leakage current</b>						
I <sub>LH</sub> I <sub>LL</sub>	Data bus high Data bus low	V <sub>O</sub> = 4V V <sub>O</sub> = 0.45V			10 10	μA
I <sub>CC</sub>	Power supply current				150	mA

CAPACITANCE T<sub>A</sub> = 25°C, V<sub>CC</sub> = 0V

SYMBOL	PARAMETER	TEST CONDITIONS	LIMITS			UNIT
			Min	Typ	Max	
<b>Capacitance</b>						
C <sub>IN</sub> C <sub>OUT</sub> C <sub>I/O</sub>	Input Output Input/Output	f <sub>c</sub> = 1MHz Unmeasured pins tied to ground			20 20 20	pF

## Asynchronous Communications Interface

SCN2641

AC ELECTRICAL CHARACTERISTICS  $T_A = 0^\circ\text{C}$  to  $+70^\circ\text{C}$ ,  $V_{CC} = 5V \pm 5\%$ <sup>4, 5, 6</sup>

SYMBOL	PARAMETER	TEST CONDITIONS	LIMITS			UNIT
			Min	Typ	Max	
<b>Pulse width</b>						
$t_{RES}$	Reset		1000			ns
$t_{CE}$	Chip enable		250			
$t_{CED}$	CE to CE delay		600			
<b>Setup and hold time</b>						
$t_{AS}$	Address setup		10			ns
$t_{AH}$	Address hold		10			
$t_{CS}$	$\bar{R}/\bar{W}$ control setup		10			
$t_{CH}$	$\bar{R}/\bar{W}$ control hold		10			
$t_{DS}$	Data setup for write		150			
$t_{DH}$	Data hold for write		10			
$t_{RXS}$	Rx data setup		300			
$t_{RXH}$	Rx data hold		350			
$t_{DD}$	Data delay time for read	$C_L = 150\text{pF}$			200	ns
$t_{DF}$	Data bus floating time for read	$C_L = 150\text{pF}$			100	
<b>Input clock frequency</b>						
$f_{BRG}$	Baud rate generator		1	3.6864	4	MHz
$f_{R/T}$ <sup>10</sup>	$\overline{\text{Tx}}\overline{\text{C}}$ or $\overline{\text{Rx}}\overline{\text{C}}$		DC		1	
<b>Clock state</b>						
$t_{BRH}$ <sup>9</sup>	Baud rate high		90			ns
$t_{BRL}$ <sup>9</sup>	Baud rate low		90			
$t_{R/TH}$	$\overline{\text{Tx}}\overline{\text{C}}$ or $\overline{\text{Rx}}\overline{\text{C}}$ high		480			
$t_{R/TL}$ <sup>10</sup>	$\overline{\text{Tx}}\overline{\text{C}}$ or $\overline{\text{Rx}}\overline{\text{C}}$ low		480			
$t_{TXD}$	TxD delay from falling edge of $\overline{\text{Tx}}\overline{\text{C}}$	$C_L = 150\text{pF}$			650	ns
$t_{TCS}$	Skew between TxD changing and falling edge of $\overline{\text{Tx}}\overline{\text{C}}$ output <sup>8</sup>	$C_L = 150\text{pF}$		0		

## NOTES:

- Stresses above those listed under Absolute Maximum Ratings may cause permanent damage to the device. This is a stress rating only and functional operation of the device at these or at any other condition above those indicated in the operation section of this specification is not implied.
- For operating at elevated temperatures, the device must be derated based on  $+150^\circ\text{C}$  maximum junction temperature.
- This product includes circuitry specifically designed for the protection of its internal devices from the damaging effects of excessive static charge. Nonetheless, it is suggested that conventional precautions be taken to avoid applying any voltages larger than the rated maxima.
- Parameters are valid over operating temperature range unless otherwise specified.
- All voltage measurements are referenced to ground. All time measurements are at the 50% level for inputs (except  $t_{BRH}$  and  $t_{BRL}$ ) and at 0.8V and 2.0V for outputs. Input levels swing between 0.4V and 2.4V, with a transition time of 20ns maximum.
- Typical values are at  $+25^\circ\text{C}$ , typical supply voltages and typical processing parameters.
- $\overline{\text{INTR}}$  output is open drain.
- Parameter applies when internal transmitter clock is used.
- $t_{BRH}$  and  $t_{BRL}$  measured at  $V_{IH}$  and  $V_{IL}$  respectively.
- In asynchronous local loopback mode, using 1X clock, the following parameters apply:
  - $f_{R/T} = 0.83\text{MHz}$  max
  - $t_{R/TL} = 700\text{ns}$  min

# Asynchronous Communications Interface

# SCN2641

## TIMING DIAGRAMS

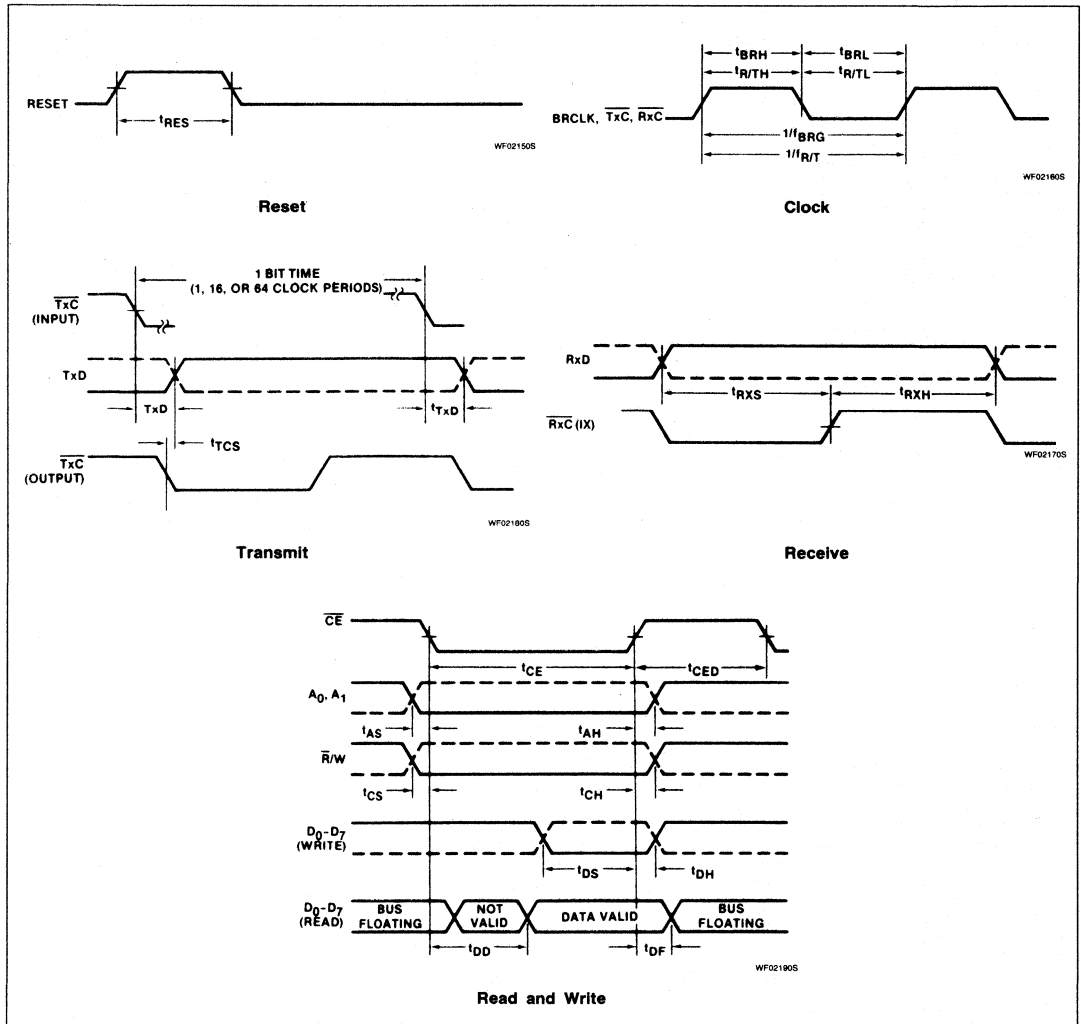



# Asynchronous Communications Interface

SCN2641

## TIMING DIAGRAMS (Continued)

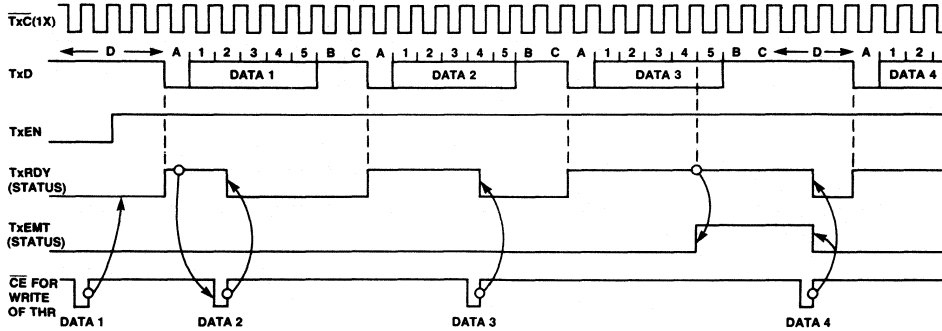

WF042205

**NOTES:**

- A = Start bit
- B = Stop bit 1
- C = Stop bit 2
- D = TxD marking condition
- TxE<sub>MT</sub> goes low at the beginning of the last data bit, or, if parity is enabled, at the beginning of the parity bit.

**TxRDY, TxEMT (Shown for 5-bit characters, no parity, 2 stop bits)**

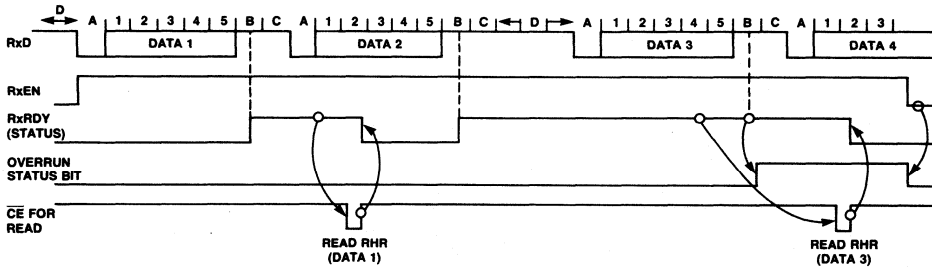

WF042305

**NOTES:**

- A = Start bit
- B = Stop bit 1
- C = Stop bit 2
- D = TxD marking condition
- Only one stop bit is detected.

**RxRDY (Shown for 5-bit characters, no parity, 2 stop bits)**

2

# Asynchronous Communications Interface

# SCN2641

## TIMING DIAGRAMS (Continued)

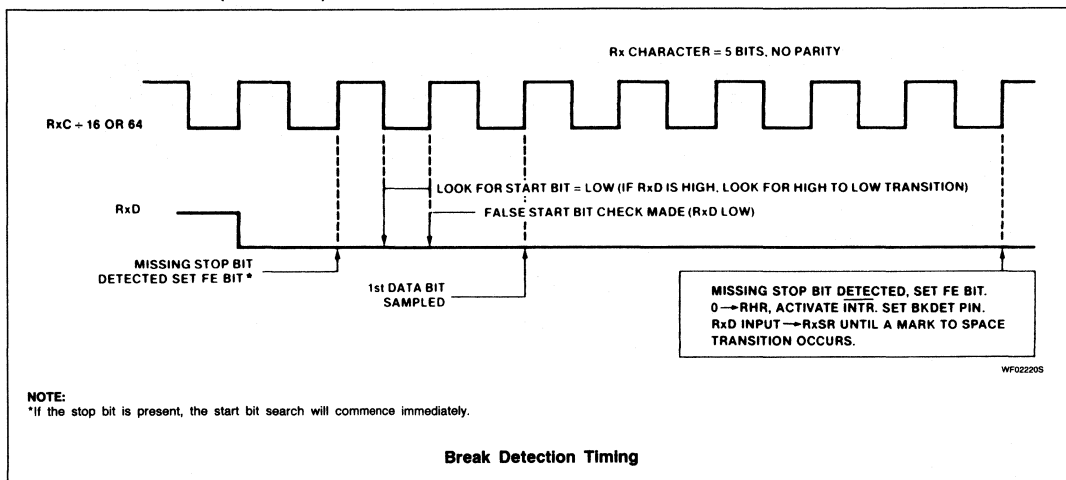

## TYPICAL APPLICATIONS

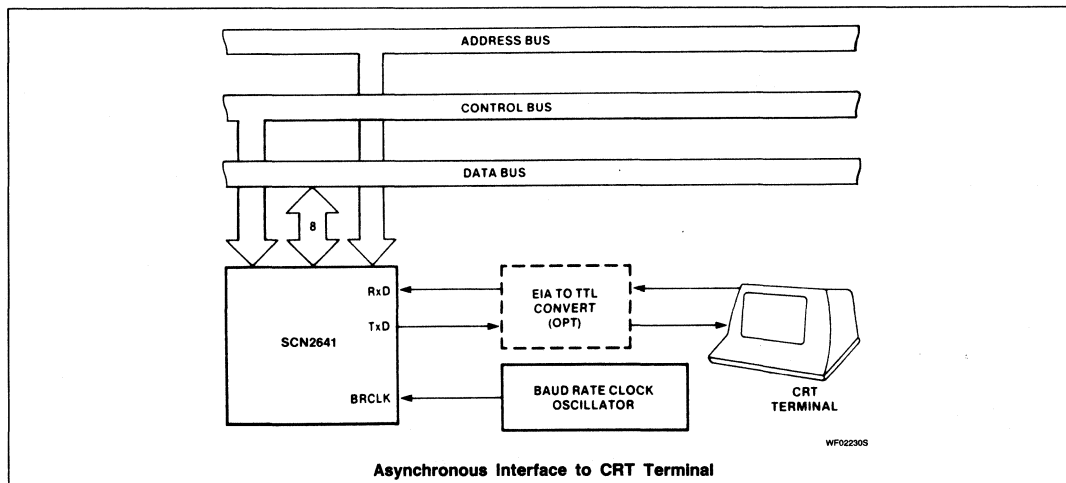

# Asynchronous Communications Interface

# SCN2641

## TYPICAL APPLICATIONS (Continued)

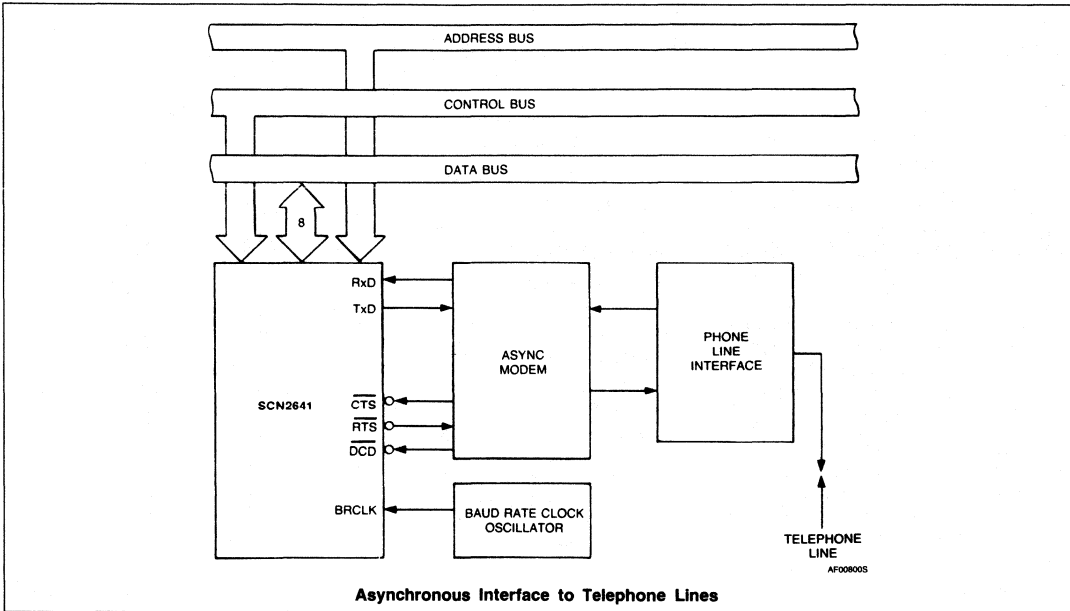

**2**

# SCN2651

## Programmable Communications Interface (PCI)

Microprocessor Products

Product Specification

### DESCRIPTION

The Signetics SCN2651 PCI is a universal synchronous/asynchronous data communications controller chip designed for microcomputer systems. It interfaces directly to the Signetics SCN2650 microprocessor and may be used in a polled or interrupt driven system environment. The SCN2651 accepts programmed instructions from the microprocessor and supports many serial data communication disciplines, synchronous and asynchronous, in the full or half-duplex mode.

The PCI serializes parallel data characters received from the microprocessor for transmission. Simultaneously, it can receive serial data and convert it into parallel data characters for input to the microcomputer.

The SCN2651 contains a baud rate generator which can be programmed to either accept an external clock or to generate internal transmit or receive clocks. Sixteen different baud rates can be selected under program control when operating in the internal clock mode.

The PCI is constructed using Signetics n-channel silicon gate depletion load technology and is packaged in a 28-pin DIP.

### FEATURES

- Synchronous operation
  - 5- to 8-bit characters
  - Single or double SYN operation
  - Internal character synchronization
  - Transparent or non-transparent mode
  - Automatic SYN or DLE-SYN insertion
  - SYN or DLE stripping
  - Odd, even, or no parity
  - Local or remote maintenance loopback mode
  - Baud rate: DC to 1M bps (1X clock)

- Asynchronous operation
  - 5- to 8-bit characters
  - 1, 1 1/2 or 2 stop bits
  - Odd, even, or no parity
  - Parity, overrun and framing error detection
  - Line break detection and generation
  - False start bit detection
  - Automatic serial echo mode
  - Local or remote maintenance loopback mode
  - Baud rate: DC to 1M bps (1X clock)  
DC to 62.5k bps (16X clock)  
DC to 15.625k bps (64X clock)
- Internal or external baud rate clock
- 16 Internal rates - 50 to 19,200 baud
- Double buffered transmitter and receiver
- Full or half duplex operation
- TTL compatible inputs and outputs
- Single 5V power supply
- No system clock required
- 28-pin dual in-line package

### APPLICATIONS

- Intelligent terminals
- Network processors
- Front-end processors
- Remote data concentrators
- Computer to computer links
- Serial peripherals

### PIN CONFIGURATION

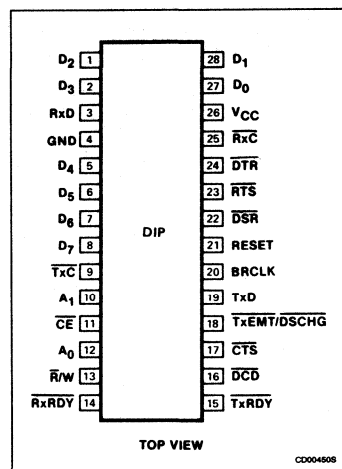

# Programmable Communications Interface (PCI)

# SCN2651

## ORDERING INFORMATION

PACKAGES	V <sub>CC</sub> = 5V ± 5%		
	Commercial	Automotive	Military
	0 to +70°C	-40°C to + 85°C	-55°C to +125°C
Ceramic DIP	SCN2651CC1I28	Contact Factory	Contact Factory
Plastic DIP	SCN2651CC1N28	Contact Factory	Not available

**2**

## BLOCK DIAGRAM

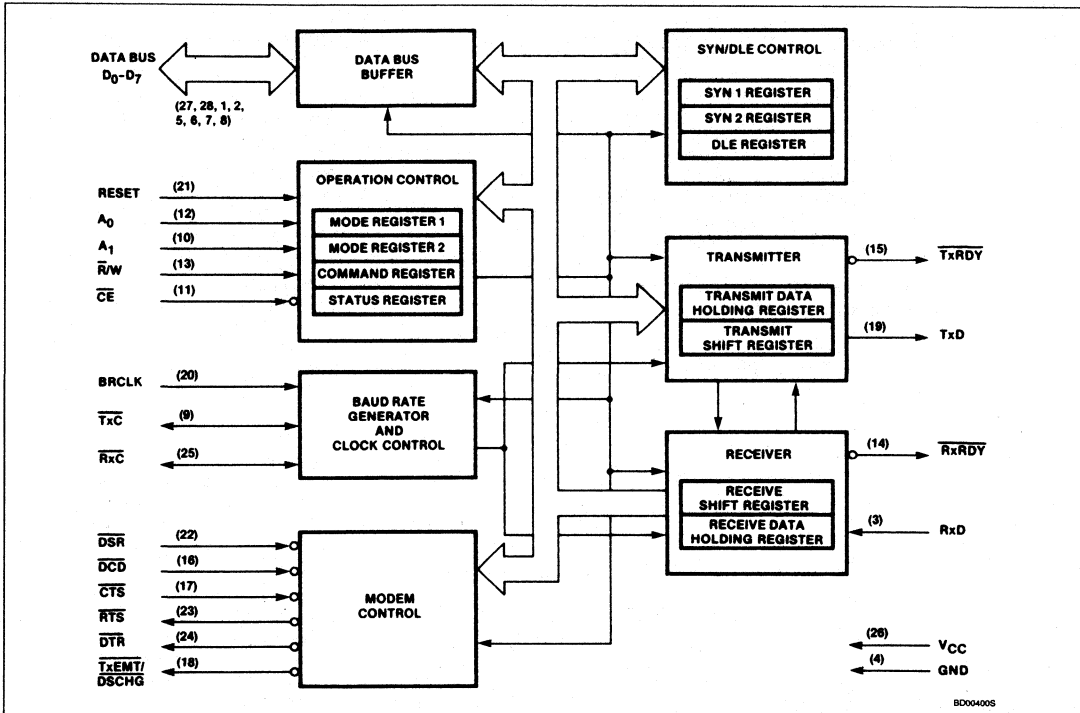

BD004006

## Programmable Communications Interface (PCI)

SCN2651

## PIN DESCRIPTION

PIN NO.	SYMBOL	NAME AND FUNCTION	TYPE
27, 28, 1, 2, 5-8	D <sub>0</sub> -D <sub>7</sub>	8-bit data bus	I/O
21	RESET	Reset	I
12,10	A <sub>0</sub> -A <sub>1</sub>	Internal register select lines	I
13	R/W	Read or write command	I
11	CE	Chip enable input	I
22	DSR	Data set ready	I
24	DTR	Data terminal ready	O
23	RTS	Request to send	O
17	CTS	Clear to send	I
16	DCD	Data carrier detected	I
18	TxE <sub>MT</sub> /D <sub>S</sub> CHG	Transmitter empty or data set change	O
9	TxC	Transmitter clock	I/O
25	RxC	Receiver clock	I/O
19	TxD	Transmitter data	O
3	RxD	Receiver data	I
15	TxRDY	Transmitter ready	O
14	RxRDY	Receiver ready	O
20	BRCLK	Baud rate generator clock	I
26	V <sub>CC</sub>	+5V supply	I
4	GND	Ground	I

**Table 1. Baud Rate Generator Characteristics**  
Crystal Frequency = 5.0688MHz

BAUD RATE	THEORETICAL FREQUENCY 16X CLOCK	ACTUAL FREQUENCY 16X CLOCK	PERCENT ERROR	DIVISOR
50	0.8KHz	0.8KHz	—	6336
75	1.2	1.2	—	4224
110	1.76	1.76	—	2880
134.5	2.152	2.1523	0.016	2355
150	2.4	2.4	—	2112
300	4.8	4.8	—	1056
600	9.6	9.6	—	528
1200	19.2	19.2	—	264
1800	28.8	28.8	—	176
2000	32.0	32.081	0.253	158
2400	38.4	38.4	—	132
3600	57.6	57.6	—	88
4800	76.8	76.8	—	66
7200	115.2	115.2	—	44
9600	153.6	153.6	—	33
19200*	307.2	316.8	3.125	16

## NOTES:

- \*Error at 19200 can be reduced to zero by using crystal frequency 4.9152MHz.
- 16X clock is used in asynchronous mode. In synchronous mode, clock multiplier is 1X.

## BLOCK DIAGRAM

The PCI consists of these six major sections: the transmitter, receiver, timing, operation control, modem control and SYN/DLE control. These sections communicate with each other via an internal data bus and an internal

control bus. The internal data bus interfaces to the microprocessor data bus via a data bus buffer.

## Operation Control

This functional block stores configuration and operation commands from the CPU and gen-

erates appropriate signals to various internal sections to control the overall device operation. It contains read and write circuits to permit communications with the microprocessor via the data bus and contains mode registers 1 and 2, the command register, and the status register. Details of register addressing and protocol are presented in the PCI programming section of this data sheet.

## Timing

The PCI contains a baud rate generator (BRG) which is programmable to accept external transmit or receive clocks or to divide an external clock to perform data communications. The unit can generate 16 commonly used baud rates, any one of which can be selected for full duplex operation (see Table 1).

## Receiver

The receiver accepts serial data on the RxD pin, converts this serial input to parallel format, checks for bits or characters that are unique to the communication technique and sends an "assembled" character to the CPU.

## Transmitter

The transmitter accepts parallel data from the CPU, converts it to a serial bit stream, inserts the appropriate characters or bits (based on the communication technique) and outputs a composite serial stream of data on the TxD output pin.

## Modem Control

The modem control section provides interfacing for three input signals and three output signals used for "handshaking" and status indication between the CPU and a modem.

## SYN/DLE Control

This section contains control circuitry and three 8-bit registers storing the SYN1, SYN2, and DLE characters provided by the CPU. These registers are used in the synchronous mode of operation to provide the characters required for synchronization, idle fill and data transparency.

## INTERFACE SIGNALS

The PCI interface signals can be grouped into two types: the CPU-related signals (shown in Table 2), which interface the SCN2651 to the microprocessor system, and the device-related signals (shown in Table 3), which are used to interface to the communications device or system.

## Programmable Communications Interface (PCI)

SCN2651

Table 2. CPU-Related Signals

PIN NAME	PIN NO.	INPUT/OUTPUT	FUNCTION
V <sub>CC</sub>	26	I	+5V supply input
GND	4	I	Ground
RESET	21	I	A high on this input performs a master reset on the SCN2651. This signal asynchronously terminates any device activity and clears the mode, command and status registers. The device assumes the idle state and remains there until initialized with the appropriate control words.
A <sub>1</sub> - A <sub>0</sub>	10, 12	I	Address lines used to select internal PCI registers.
$\bar{R}/W$	13	I	Read command when low, write command when high.
$\overline{CE}$	11	I	Chip enable command. When low, indicates that control and data lines to the PCI are valid and that the operation specified by the $\bar{R}/W$ , A <sub>1</sub> and A <sub>0</sub> inputs should be performed. When high, places the D <sub>0</sub> - D <sub>7</sub> lines in the 3-State condition.
D <sub>7</sub> - D <sub>0</sub>	8, 7, 6, 5, 2, 1, 28, 27	I/O	8-bit, 3-State data bus used to transfer commands, data and status between PCI and the CPU. D <sub>0</sub> is the least significant bit; D <sub>7</sub> the most significant bit.
$\overline{TxRDY}$	15	O	This output is the complement of status register bit SR0. When low, it indicates that the transmit data holding register (THR) is ready to accept a data character from the CPU. It goes high when the data character is loaded. This output is valid only when the transmitter is enabled. It is an open drain output which can be used as an interrupt to the CPU.
$\overline{RxRDY}$	14	O	This output is the complement of status register bit SR1. When low, it indicates that the receive data holding register (RHR) has a character ready for input to the CPU. It goes high when the RHR is read by the CPU, and also when the receiver is disabled. It is an open drain output which can be used as an interrupt to the CPU.
$\overline{TxEMT}/\overline{DSCHG}$	18	O	This output is the complement of status register bit SR2. When low, it indicates that the transmitter has completed serialization of the last character loaded by the CPU, or that a change of state of the $\overline{DSR}$ or $\overline{DCD}$ inputs has occurred. This output goes high when the status register is read by the CPU, if the TxEMT condition does not exist. Otherwise, the THR must be loaded by the CPU for this line to go high. It is an open drain output which can be used as an interrupt to the CPU.

**OPERATION**

The functional operation of the SCN2651 is programmed by a set of control words supplied by the CPU. These control words specify items such as synchronous or asynchronous mode, baud rate, number of bits per character, etc. The programming procedure is described in the PCI programming section of this data sheet.

After programming, the PCI is ready to perform the desired communications functions. The receiver performs serial to parallel conversion of data received from a modem or equivalent device. The transmitter converts parallel data received from the CPU to a serial bit stream. These actions are accomplished within the framework specified by the control words.

**Receiver**

The SCN2651 is conditioned to receive data when the  $\overline{DCD}$  input is low and the RxEN bit in the command register is true. In the asynchronous mode, the receiver looks for a high to low transition of the start bit on the RxD input line. If a transition is detected, the state of the RxD line is sampled again after a delay of one-half of a bit time. If RxD is now high,

the search for a valid start bit is begun again. If RxD is still low, a valid start bit is assumed and the receiver continues to sample the input line at one bit time intervals until the proper number of data bits, the parity bit, and the stop bit(s) have been assembled. The data is then transferred to the receive data holding register, the RxRDY bit in the status register is set, and the  $\overline{RxRDY}$  output is asserted. If the character length is less than 8 bits, the high order unused bits in the holding register are set to zero. The parity error, framing error, and overrun error status bits are strobed into the status register on the positive going edge of  $\overline{RxC}$  corresponding to the received character boundary. If a break condition is detected (RxD is low for the entire character as well as the stop bit(s)), only one character consisting of all zeros (with the FE status bit set) will be transferred to the holding register. The RxD input must return to a high condition before a search for the next start bit begins.

When the PCI is initialized into the synchronous mode, the receiver first enters the hunt mode on a 0 to 1 transition of RxEN (CR2). In this mode, as data is shifted into the receiver

shift register a bit at a time, the contents of the register are compared to the contents of the SYN1 register. If the two are not equal, the next bit is shifted in and the comparison is repeated. When the two registers match, the hunt mode is terminated and character assembly mode begins. If single SYN operation is programmed, the SYN detect status bit is set. If double SYN operation is programmed, the first character assembled after SYN1 must be SYN2 in order for the SYN detect bit to be set. Otherwise, the PCI returns to the hunt mode. (Note that the sequence SYN1 - SYN1 - SYN2 will not achieve synchronization). When synchronization has been achieved, the PCI continues to assemble characters and transfer them to the holding register, setting the RxRDY status bit and asserting the  $\overline{RxRDY}$  output each time a character is transferred. The PE and OE status bits are set as appropriate. Further receipt of the appropriate SYN sequence sets the SYN detect status bit. If the SYN stripping mode is commanded, SYN characters are not transferred to the Holding Register. Note that the SYN characters used to establish initial synchronization are not transferred to the holding register in any case.

## Programmable Communications Interface (PCI)

SCN2651

Table 3. Device-Related Signals

PIN NAME	PIN NO.	INPUT/OUTPUT	FUNCTION
BRCLK	20	I	5.0688MHz clock input to the internal baud rate generator. Not required if external receiver and transmitter clocks are used.
$\overline{\text{RxC}}$	25	I/O	Receiver clock. If external receiver clock is programmed, this input controls the rate at which the character is to be received. Its frequency is 1X, 16X or 64X the baud rate, as programmed by mode register 1. Data is sampled on the rising edge of the clock. If internal receiver clock is programmed, this pin becomes an output at 1X the programmed baud rate.*
$\overline{\text{TxC}}$	9	I/O	Transmitter clock. If external transmitter clock is programmed, this input controls the rate at which the character is transmitted. Its frequency is 1X, 16X or 64X the baud rate, as programmed by mode register 1. The transmitted data changes on the falling edge of the clock. If internal transmitter clock is programmed, the pin becomes an output at 1X the programmed baud rate.*
RxD	3	I	Serial data input to the receiver. "Mark" is high, "Space" is low.
TxD	19	O	Serial data output from the transmitter. "Mark" is high, "space" is low. Held in mark condition when the transmitter is disabled.
$\overline{\text{DSR}}$	22	I	General purpose input which can be used for data set ready or ring indicator condition. Its complement appears as status register bit SR7. Causes a low output on $\overline{\text{TxE}}/\overline{\text{DSCHG}}$ when its state changes.
$\overline{\text{DCD}}$	16	I	Data carrier detect input. Must be low in order for the receiver to operate. Its complement appears as status register bit SR6. Causes a low output on $\overline{\text{TxE}}/\overline{\text{DSCHG}}$ when its state changes.
$\overline{\text{CTS}}$	17	I	Clear to send input. Must be low in order for the transmitter to operate. If it goes high during transmission, the character in the transmit shift register will be transmitted before termination.
$\overline{\text{DTR}}$	24	O	General purpose output which is the complement of command register bit CR1. Normally used to indicate data terminal ready.
$\overline{\text{RTS}}$	23	O	General purpose output which is the complement of command register bit CR5. Normally used to indicate request to send.

**NOTE:**\* $\overline{\text{RxC}}$  and  $\overline{\text{TxC}}$  outputs have short circuit protection max.  $C_L = 100\text{pF}$ **Transmitter**

The PCI is conditioned to transmit data when the  $\overline{\text{CTS}}$  input is low and the TxEN command register bit is set. The SCN2651 indicates to the CPU that it can accept a character for transmission by setting the TxRDY status bit and asserting the  $\overline{\text{TxDY}}$  output. When the CPU writes a character into the transmit data holding register, these conditions are negated. Data is transferred from the holding register to the transmit shift register when it is idle or has completed transmission of the previous character. The TxRDY conditions are then asserted again. Thus, one full character time of buffering is provided.

In the asynchronous mode, the transmitter automatically sends a start bit followed by the programmed number of data bits, the least significant bit being sent first. It then appends an optional odd or even parity bit and the programmed number of stop bits. If, following transmission of the data bits, a new character is not available in the transmit holding register, the TxD output remains in the marking (high) condition and the  $\overline{\text{TxE}}/\overline{\text{DSCHG}}$  out-

put and its corresponding status bit are asserted. Transmission resumes when the CPU loads a new character into the holding register. The transmitter can be forced to output a continuous low (BREAK) condition by setting the send break command bit high.

In the synchronous mode, when the SCN2651 is initially conditioned to transmit, the TxD output remains high and the TxRDY condition is asserted until the first character to be transmitted (usually a SYN character) is loaded by the CPU. Subsequent to this, a continuous stream of characters is transmitted. No extra bits (other than parity, if commanded) are generated by the PCI unless the CPU fails to send a new character to the PCI by the time the transmitter has completed sending the previous character.

Since synchronous communication does not allow gaps between characters, the PCI asserts TxEMT and automatically "fills" the gap by transmitting SYN1s, SYN1 - SYN2 doublets, or DLE - SYN1 doublets, depending on the state of MR16 and MR17. Normal transmission of the message resumes when a new

character is available in the transmit data holding register. If the send DLE bit in the command register is true, the DLE character is automatically transmitted prior to transmission of the message character in THR.

**PCI PROGRAMMING**

Prior to initiating data communications, the SCN2651 operational mode must be programmed by performing write operations to the mode and command registers. In addition, if synchronous operation is programmed, the appropriate SYN/DLE registers must be loaded. The PCI can be reconfigured at any time during program execution. However, if the change has an effect on the reception of a character the receiver should be disabled. Alternatively if the change is made 1/2 RxC periods after RxRDY goes active it will affect the next character assembly. A flowchart of the initialization process appears in Figure 1.

The internal registers of the PCI are accessed by applying specific signals to the  $\overline{\text{CE}}$ ,  $\overline{\text{R/W}}$ ,  $A_1$  and  $A_0$  inputs. The conditions necessary to address each register are shown in Table 4.



Programmable Communications Interface (PCI)

SCN2651

2

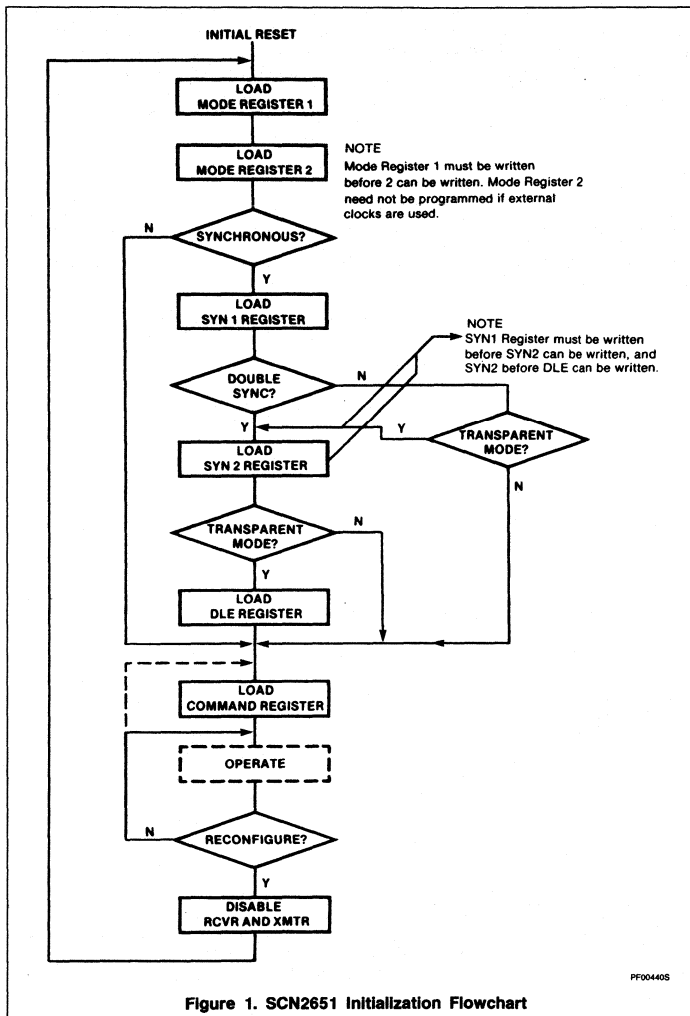

Figure 1. SCN2651 Initialization Flowchart

PF004405

Table 4. SCN2651 Register Addressing

CE	A <sub>1</sub>	A <sub>0</sub>	R/W	FUNCTION
1	X	X	X	3-State data bus
0	0	0	0	Read receive holding register
0	0	0	1	Write transmit holding register
0	0	1	0	Read status register
0	0	1	1	Write SYN1/SYN2/DLE registers
0	1	0	0	Read mode registers 1/2
0	1	0	1	Write mode registers 1/2
0	1	1	0	Read command register
0	1	1	1	Write command register

NOTE:  
See AC Characteristics section for timing requirements.

The SYN1, SYN2, and DLE registers are accessed by performing write operations with the conditions A<sub>1</sub> = 0, A<sub>0</sub> = 1, and R/W = 1. The first operation loads the SYN1 register. The next loads the SYN2 register, and the third loads the DLE register. Reading or loading the mode registers is done in a similar manner. The first write (or read) operation addresses mode register 1, and a subsequent operation addresses mode register 2. If more than the required number of accesses are made, the internal sequencer recycles to point at the first register. The pointers are reset to SYN1 register and mode register 1 by a RESET input or by performing a "read command register" operation, but are unaffected by any other read or write operation.

The SCN2651 register formats are summarized in tables 5, 6, 7 and 8. Mode registers 1 and 2 define the general operational characteristics of the PCI, while the command register controls the operation within this basic framework. The PCI indicates its status in the status register. These registers are cleared when a RESET input is applied.

**Mode Register 1 (MR1)**

Table 5 illustrates mode register 1. Bits MR11 and MR10 select the communication format and baud rate multiplier. 00 specifies synchronous mode and 1X multiplier. 1X, 16X, and 64X multipliers are programmable for asynchronous format. However, the multiplier in asynchronous format applies only if the external clock input option is selected by MR24 or MR25.

MR13 and MR12 select a character length of 5, 6, 7, or 8 bits. The character length does not include the parity bit, if programmed, and does not include the start and stop bits in asynchronous mode.

MR14 controls parity generation. If enabled, a parity bit is added to the transmitted character and the receiver performs a parity check on incoming data. MR15 selects odd or even parity when parity is enabled by MR14.

In asynchronous mode, MR17 and MR16 select character framing of 1, 1.5, or 2 stop bits. (If 1X baud rate is programmed, 1.5 stop bits default to 1 stop bit on transmit). In synchronous mode, MR17 controls the number of SYN characters used to establish synchronization and for character fill when the transmitter is idle. SYN1 alone is used if MR17 = 1, and SYN1 - SYN2 is used when MR17 = 0. If the transparent mode is specified by MR16, DLE - SYN1 is used for character fill and SYN detect, but the normal synchronization sequence is used. Also DLE stripping and DLE detect (with MR14 = 0) are enabled.

## Programmable Communications Interface (PCI)

SCN2651

**Mode Register 2 (MR2)**

Table 6 illustrates mode register 2. MR23, MR22, MR21, and MR20 control the frequency of the internal baud rate generator (BRG). Sixteen rates are selectable. When driven by a 5.0688MHz input at the BRCLK input

(pin 20), the BRG output has zero error except at 134.5, 2000, and 19,200 baud, which have errors of +0.016%, +0.235%, and +3.125% respectively.

TR25 and MR24 select either the BRG or the external inputs Tx $\bar{C}$  and Rx $\bar{C}$  as the clock

source for the transmitter and receiver, respectively. If the BRG clock is selected, the baud rate factor in asynchronous mode is 16X regardless of the factor selected by MR11 and MR10. In addition, the corresponding clock pin provides an output at 1X the baud rate.

**Table 5. Mode Register 1 (MR1)**

MR17	MR16	MR15	MR14	MR13	MR12	MR11	MR10
		<b>Parity Type</b>	<b>Parity Control</b>	<b>Character Length</b>		<b>Mode and Baud Rate Factor</b>	
<b>Asynch: Stop bit length</b> 00 = Invalid 01 = 1 Stop bit 10 = 1½ Stop bits 11 = 2 Stop bits		0 = Odd 1 = Even	0 = Disabled 1 = Enabled	00 = 5 Bits 01 = 6 Bits 10 = 7 Bits 11 = 8 Bits		00 = Synchronous 1X rate 01 = Asynchronous 1X rate 10 = Asynchronous 16X rate 11 = Asynchronous 64X rate	
<b>Synch: Number of syn char</b> 0 = Double SYN 1 = Single SYN	<b>Synch: Transparency control</b> 0 = Normal 1 = Transparent						

**NOTE:**

Baud rate factor in asynchronous applies only if external clock is selected. Factor is 16X if internal clock is selected. Mode must be selected (MR11, MR10) in any case.

**Table 6. Mode Register 2 (MR2)**

MR27	MR26	MR25	MR24	MR23	MR22	MR21	MR20
Not used		<b>Transmitter Clock</b>	<b>Receiver Clock</b>	<b>Baud Rate Selection</b>			
		0 = External 1 = Internal	0 = External 1 = Internal	0000 = 50 Baud 0001 = 75 0010 = 110 0011 = 134.5 0100 = 150 0101 = 300 0110 = 600 0111 = 1200	1000 = 1800 Baud 1001 = 2000 1010 = 2400 1011 = 3600 1100 = 4800 1101 = 7200 1110 = 9600 1111 = 19,200		

**Table 7. Command Register (CR)**

CR7	CR6	CR5	CR4	CR3	CR2	CR1	CR0
<b>Operating Mode</b>		<b>Request to Send</b>	<b>Reset Error</b>		<b>Receive Control (RxEN)</b>	<b>Data Terminal Ready</b>	<b>Transmit Control (TxEN)</b>
00 = Normal operation 01 = Asynch: automatic echo mode Synch: SYN and/or DLE stripping mode 10 = Local Loopback 11 = Remote Loopback		0 = Force RTS output high 1 = Force RTS output low	0 = Normal 1 = Reset error flag in status reg (FE, OE, PE/DLE DETECT)	<b>Asynch:</b> <b>Force break</b> 0 = Normal 1 = Force break <b>Synch</b> <b>Send DLE</b> 0 = Normal 1 = Send DLE	0 = Disable 1 = Enable	0 = Force DTR output high 1 = Force DTR output low	0 = Disable 1 = Enable

## Programmable Communications Interface (PCI)

SCN2651

Table 8. Status Register (SR)

SR7	SR6	SR5	SR4	SR3	SR2	SR1	SR0
Data Set Ready	Data Carrier Detect	FE/SYN Detect	Overrun	PE/DLE Detect	TxE $\overline{M}$ T/D $\overline{S}$ CHG	RxRDY	TxRDY
0 = DSR Input is high 1 = DSR Input is low	0 = DCD Input is high 1 = DCD Input is low	Asynch: 0 = Normal 1 = Framing ERROR Synch: 0 = Normal 1 = SYN char detected	0 = Normal 1 = Overrun error	Asynch: 0 = Normal 1 = Parity error Synch: 0 = Normal 1 = Parity error or DLE char received	0 = Normal 1 = Change in DSR or DCD, or transmit shift register is empty	0 = Receive holding reg empty 1 = Receive holding reg has data	0 = Transmit holding reg busy 1 = Transmit holding reg empty

**Command Register (CR)**

Table 7 illustrates command register. Bits CR0 (TxEN) and CR2 (RxEN) enable or disable the transmitter and receiver respectively. A 0 to 1 transition of CR2 forces start bit search (async mode) or hunt mode (sync mode) on the second  $\overline{RxC}$  rising edge. Disabling the receiver causes  $\overline{RxRDY}$  to go high (inactive). If the transmitter is disabled, it will complete the transmission of the character in the transmit shift register (if any) prior to terminating operation. The Tx $\overline{D}$  output will then remain in the marking state (high) while the TxRDY and TxEMT will go high (inactive). If the receiver is disabled, it will terminate operation immediately. Any character being assembled will be neglected.

Bits CR1 (DTR) and CR5 (RTS) control the DTR and RTS outputs. Data at the outputs is the logical complement of the register data.

In asynchronous mode, setting CR3 will force and hold the Tx $\overline{D}$  output low (spacing condition) at the end of the current transmitted character. Normal operation resumes when CR3 is cleared. The Tx $\overline{D}$  line will go high for at least one bit time before beginning transmission of the next character in the transmit data holding register. In synchronous mode, setting CR3 causes the transmission of the DLE register contents prior to sending the character in the transmit data holding register. CR3 should be reset in response to the next TxRDY.

Setting CR4 causes the error flags in the status register (SR3, SR4, and SR5) to be cleared. This is a one time command. There is no internal latch for this bit.

The PCI can operate in one of four submodes within each major mode (synchronous or asynchronous). The operational submode is determined by CR7 and CR6. CR7 - CR6 = 00 is the normal mode, with the transmitter and receiver operating independently in accordance with the mode and status register instructions.

In asynchronous mode, CR7 - CR6 = 01 places the PCI in the automatic echo mode. Clocked, regenerated received data is auto-

matically directed to the Tx $\overline{D}$  line while normal receiver operation continues. The receiver must be enabled (CR2 = 1), but the transmitter need not be enabled. CPU to receiver communications continues normally, but the CPU to transmitter link is disabled. Only the first character of a break condition is echoed. The Tx $\overline{D}$  output will go high until the next valid start is detected.

The following conditions are true while in automatic echo mode:

1. Data assembled by the receiver is automatically placed in the transmit holding register and retransmitted by the transmitter on the Tx $\overline{D}$  output.
2. The transmitter is clocked by the receive clock.
3.  $\overline{TxRDY}$  output = 1.
4. The TxEMT/D $\overline{S}$ CHG pin will reflect only the data set change condition.
5. The TxEN command (CR0) is ignored.

In synchronous mode, CR7 - CR6 = 01 places the PCI in the automatic SYN/DLE stripping mode. The exact action taken depends on the setting of bits MR17 and MR16:

1. In the non-transparent, single SYN mode (MR17 - MR16 = 10), characters in the data stream matching SYN1 are not transferred to the receive data holding register (RHR).
2. In the non-transparent, double SYN mode (MR17 - MR16 = 00), characters in the data stream matching SYN1, or SYN2 if immediately preceded by SYN1, are not transferred to the RHR. However, only the first SYN1 of an SYN1 - SYN1 pair is stripped.
3. In transparent mode (MR16 = 1), characters in the data stream matching DLE, or SYN1 if immediately preceded by DLE, are not transferred to the RHR. However, only the first DLE of a DLE - DLE pair is stripped.

Note that automatic stripping mode does not affect the setting of the DLE detect and SYN detect status bits (SR3 and SR5).

Two diagnostic submodes can also be configured. In local loopback mode (CR7 - CR6 = 10), the following loops are connected internally:

1. The transmitter output is connected to the receiver input.
2. DTR is connected to DCD and RTS is connected to CTS.
3. The receiver is clocked by the transmit clock.
4. The DTR, RTS and Tx $\overline{D}$  outputs are held high.
5. The CTS, DCD, DSR and Rx $\overline{D}$  inputs are ignored.

Additional requirements to operate in the local loopback mode are that CR0 (TxEN), CR1 (DTR), and CR5 (RTS) must be set to 1. CR2 (RxEN) is ignored by the PCI.

The second diagnostic mode is the remote loopback mode (CR7 - CR6 = 11). In this mode:

1. Data assembled by the receiver is automatically placed in the transmit holding register and retransmitted by the transmitter on the Tx $\overline{D}$  output.
2. The transmitter is clocked by the receive clock.
3. No data is sent to the local CPU, but the error status conditions (PE, OE, FE) are set.
4. The RxRDY, TxRDY, and TxEMT/D $\overline{S}$ CHG outputs are held high.
5. CR0 (TxEN) is ignored.
6. All other signals operate normally.

**Status Register**

The data contained in the status register (as shown in Table 8) indicate receiver and transmitter conditions and modem/data set status.

SR0 is the transmitter ready (TxRDY) status bit. It, and its corresponding output, are valid only when the transmitter is enabled. If equal to 0, it indicates that the transmit data holding register has been loaded by the CPU and the data has not been transferred to the transmit shift register. If set equal to 1, it indicates that

---

## Programmable Communications Interface (PCI)

---

SCN2651

the Holding Register is ready to accept data from the CPU. This bit is initially set when the transmitter is enabled by CR0, unless a character has previously been loaded into the holding register. It is not set when the automatic echo or remote loopback modes are programmed. When this bit is set, the  $\overline{\text{TxRDY}}$  output pin is low. In the automatic echo and remote loopback modes, the output is held high.

SR1, the receiver ready ( $\text{RxRDY}$ ) status bit, indicates the condition of the receive data holding register. If set, it indicates that a character has been loaded into the holding register from the receive shift register and is ready to be read by the CPU. If equal to zero, there is no new character in the holding register. This bit is cleared when the CPU reads the receive data holding register or when the receiver is disabled by CR2. When set, the  $\overline{\text{RxRDY}}$  output is low.

The  $\text{TxEMT/DSCHG}$  bit, SR2, when set, indicates either a change of state of the  $\overline{\text{DSR}}$  or  $\overline{\text{DCD}}$  inputs or that the transmit shift register has completed transmission of a character and no new character has been

loaded into the transmit data holding register. Note that in synchronous mode this bit will be set even though the appropriate "fill" character is transmitted.  $\text{TxEMT}$  will not go active until at least one character has been transmitted. It is cleared by loading the transmit data holding register. The  $\text{DSCHG}$  condition is enabled when  $\text{TxEN} = 1$  or  $\text{RxEN} = 1$ . If the status register is read twice and  $\text{SR2} = 1$  while SR6 and SR7 remain unchanged, then a  $\text{TxEMT}$  condition exists. It is cleared when the status register is read by the CPU. When SR2 is set, the  $\text{TxEMT/DSCHG}$  output is low.

SR3, when set, indicates a received parity error when parity is enabled by MR14. In synchronous transparent mode ( $\text{MR16} = 1$ ), with parity disabled, it indicates that a character matching the DLE register has been received. However, only the first DLE of two successive DLEs will set SR3. This bit is cleared when the receiver is disabled and by the reset error command, CR4.

The overrun error status bit, SR4, indicates that the previous character loaded into the receive holding register was not read by the CPU at the time a new received character

was transferred into it. This bit is cleared when the receiver is disabled and by the reset error command, CR4.

In asynchronous mode, bit SR5 signifies that the received character was not framed by the programmed number of stop bits. (If 1.5 stop bits are programmed, only the first stop bit is checked.) If  $\text{RHR} = 0$  when  $\text{SR5} = 1$  a break condition is present. In synchronous non-transparent mode ( $\text{MR16} = 0$ ), it indicates receipt of the SYN1 character is single SYN mode or the SYN1 – SYN2 pair in double SYN mode. In synchronous transparent mode ( $\text{MR16} = 1$ ), this bit is set upon detection of the initial synchronizing characters (SYN1 or SYN1 – SYN2) and, after synchronization has been achieved, when a DLE – SYN1 pair is received. The bit is reset when the receiver is disabled, when the reset error command is given in asynchronous mode, and when the status register is read by the CPU in the synchronous mode.

SR6 and SR7 reflect the conditions of the  $\overline{\text{DCD}}$  and  $\overline{\text{DSR}}$  inputs respectively. A low input sets its corresponding status bit and a high input clears it.

## Programmable Communications Interface (PCI)

SCN2651

**2****ABSOLUTE MAXIMUM RATINGS<sup>1</sup>**

SYMBOL	PARAMETER	RATING	UNIT
T <sub>A</sub>	Operating ambient temperature <sup>2</sup>	Note 4	°C
T <sub>STG</sub>	Storage temperature range	-65 to +150	°C
	All voltages with respect to ground <sup>3</sup>	-0.5 to +6	V

**DC ELECTRICAL CHARACTERISTICS<sup>4, 5, 6</sup>**

SYMBOL	PARAMETER	TEST CONDITIONS	LIMITS			UNIT
			Min	Typ	Max	
<b>Input voltage</b>						
V <sub>IL</sub> V <sub>IH</sub>	Low High		2		0.8	V
<b>Output voltage</b>						
V <sub>OL</sub> V <sub>OH</sub>	Low High	I <sub>OL</sub> = 1.6mA I <sub>OH</sub> = -100μA	2.4		0.4	V
I <sub>IL</sub>	Input leakage current	V <sub>IN</sub> = 0 to 5.25V	-10		10	μA
<b>3-State output leakage current</b>						
I <sub>LH</sub> I <sub>LL</sub>	Data bus high Data bus low	V <sub>O</sub> = 4.0V V <sub>O</sub> = 0.45V	-10 -10		10 10	μA
I <sub>CC</sub>	Power supply current				150	mA

**CAPACITANCE** T<sub>A</sub> = 25°C, V<sub>CC</sub> = 0V

SYMBOL	PARAMETER	TEST CONDITIONS	LIMITS			UNIT
			Min	Typ	Max	
<b>Capacitance</b>						
C <sub>IN</sub> C <sub>OUT</sub> C <sub>I/O</sub>	Input Output Input/Output	f <sub>c</sub> = 1MHz Unmeasured pins tied to ground			20 20 20	pF

## Programmable Communications Interface (PCI)

SCN2651

AC ELECTRICAL CHARACTERISTICS<sup>4, 5, 6</sup>

SYMBOL	PARAMETER	TEST CONDITIONS	LIMITS			UNIT
			Min	Typ	Max	
<b>Pulse width</b>						
$t_{RES}$	Reset		1000			ns
$t_{CE}$	Chip enable		300			
<b>Setup and hold time</b>						
$t_{AS}$	Address setup		20			ns
$t_{AH}$	Address hold		20			
$t_{CS}$	R/W control setup		20			
$t_{CH}$	R/W control hold		20			
$t_{DS}$	Data setup for write		225			
$t_{DH}$	Data hold for write		0			
$t_{RXS}$	Rx data setup		300			
$t_{RXH}$	Rx data hold		350			
$t_{DD}$	Data delay time for read	$C_L = 100\text{pF}$			250	ns
$t_{DF}$	Data bus floating time for read	$C_L = 100\text{pF}$			150	ns
$t_{CED}$	$\overline{CE}$ to $\overline{CE}$ delay		700			ns
<b>Input clock frequency</b>						
$f_{BRG}$	Baud rate generator		1.0	5.0688	5.0738	MHz
$f_{R/T}$ <sup>10</sup>	$\overline{TxC}$ or $\overline{RxC}$		DC		1	
<b>Clock width</b>						
$t_{BRH}$ <sup>9</sup>	Baud rate high		70			ns
$t_{BRL}$ <sup>9</sup>	Baud rate low		70			
$t_{R/TH}$ <sup>10</sup>	$\overline{TxC}$ or $\overline{RxC}$ high		500			
$t_{R/TL}$ <sup>10</sup>	$\overline{TxC}$ or $\overline{RxC}$ low		500			
$t_{TXD}$	MxD delay from falling edge of $\overline{TxC}$	$C_L = 100\text{pF}$			650	ns
$t_{TCS}$	Skew between $\overline{TxD}$ changing and falling edge of $\overline{TxC}$ output <sup>8</sup>	$C_L = 100\text{pF}$		0		ns

## NOTES:

- Stresses above those listed under Absolute Maximum Ratings may cause permanent damage to the device. This is a stress rating only and functional operation of the device at these or at any other condition above those indicated in the operation section of this specification is not implied.
- For operating at elevated temperatures, the device must be derated based on +150°C maximum junction temperature.
- This product includes circuitry specifically designed for the protection of its internal devices from the damaging effects of excessive static charge. Nonetheless, it is suggested that conventional precautions be taken to avoid applying any voltages larger than the rated maxima.
- Parameters are valid over operating temperature range unless otherwise specified. See ordering code table for applicable temperature range and operating supply range.
- All voltage measurements are referenced to ground. All time measurements are at the 50% level for inputs (except  $t_{BRH}$  and  $t_{BRL}$ ) and at 0.8V and 2V for outputs. Input levels for testing 0.45V and 2.4V.
- Typical values are at +25°C, typical supply voltages and typical processing parameters.
- $\overline{TxRDY}$ ,  $\overline{RxRDY}$  and  $\overline{TxEMT/DSCHG}$  outputs are open drain.
- Parameter applies when internal transmitter clock is used.
- Under test conditions of 5.0688MHz,  $f_{BRG}$ ,  $t_{BRH}$ , and  $t_{BRL}$  measured at  $V_{IH}$  and  $V_{IL}$  respectively.
- $t_{R/T}$  and  $t_{R/TL}$  shown for all modes except local loopback. For local loopback mode  $f_{R/T} = 0.7\text{MHz}$  and  $t_{R/TL} = 700\text{ns}$  min.

Programmable Communications Interface (PCI)

SCN2651

TIMING DIAGRAMS

2

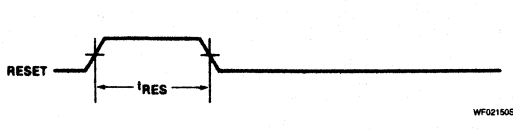

Reset

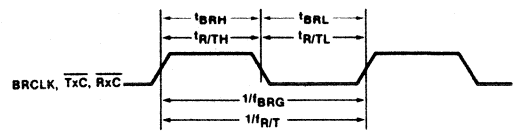

Clock

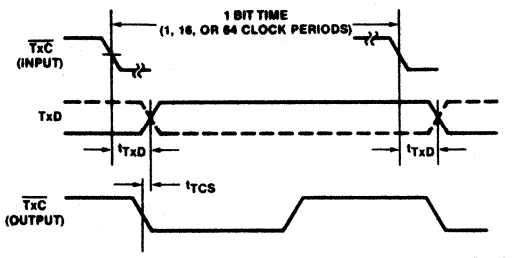

Transmit

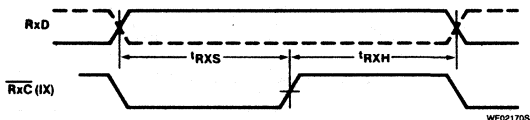

Receive

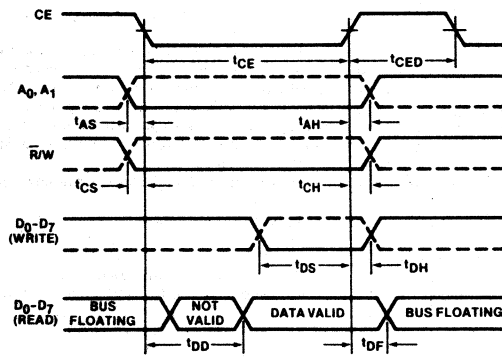

Read and Write

# Programmable Communications Interface (PCI)

SCN2651

## TIMING DIAGRAMS (Continued)

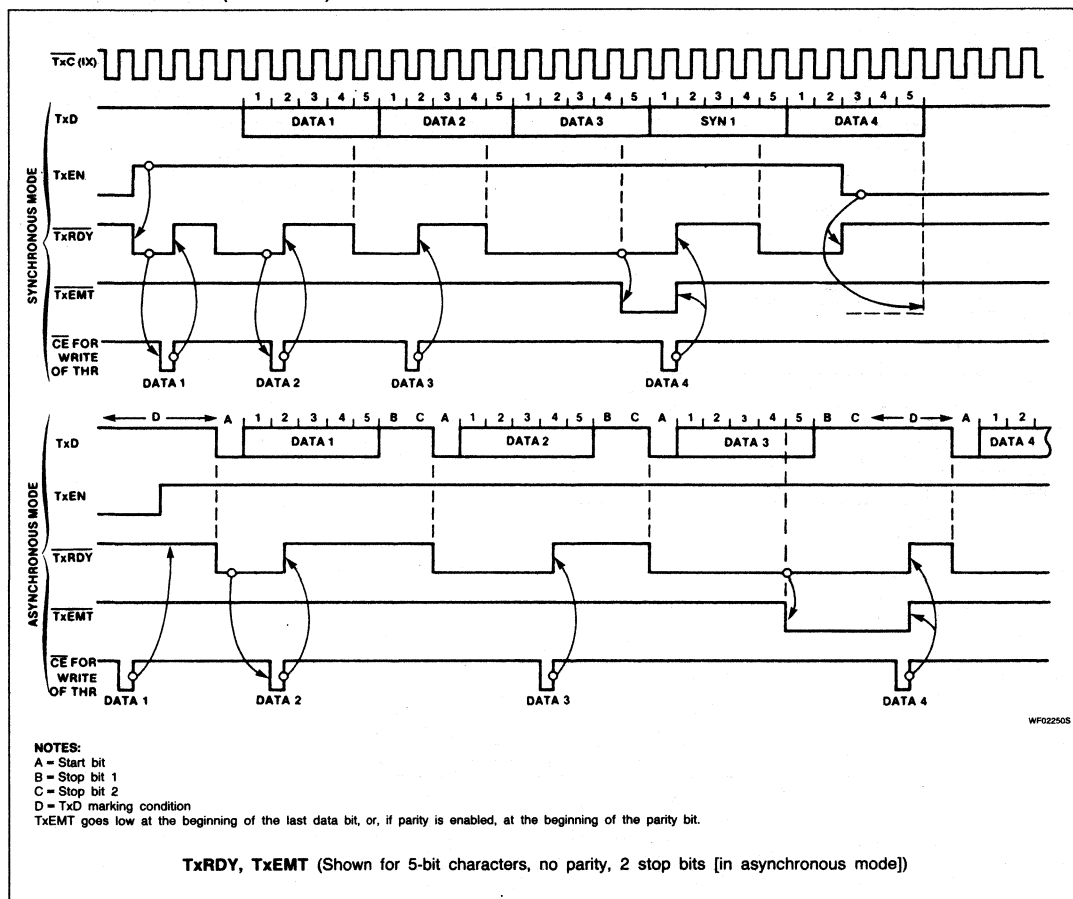

WF022505



Programmable Communications Interface (PCI)

SCN2651

TIMING DIAGRAMS (Continued)

**2**

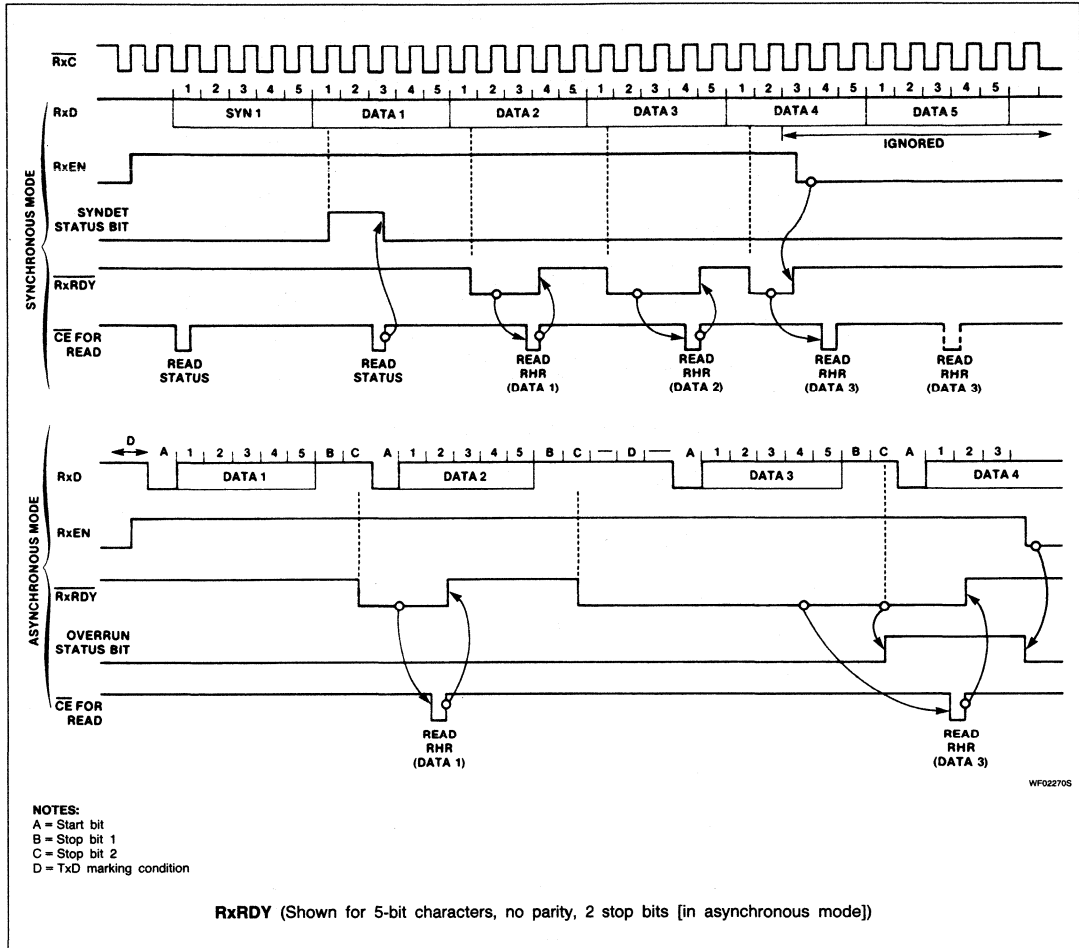

Programmable Communications Interface (PCI)

SCN2651

TYPICAL APPLICATIONS

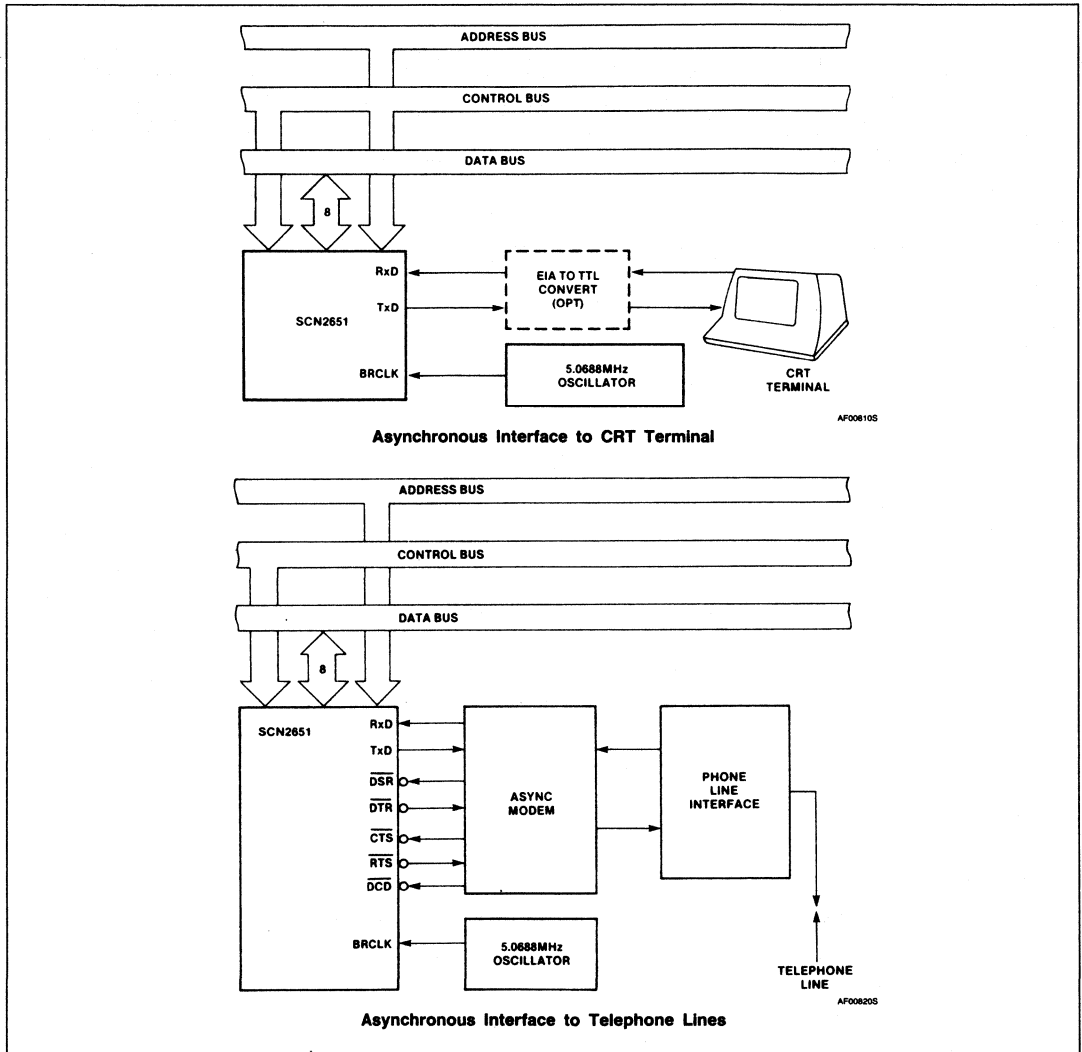

Programmable Communications Interface (PCI)

SCN2651

TYPICAL APPLICATIONS (Continued)

**2**

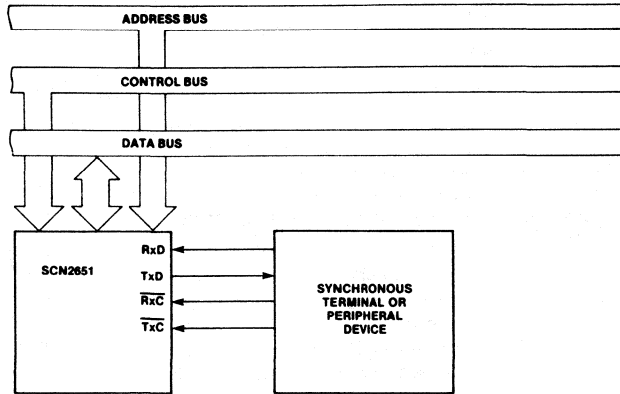

AF008305

Synchronous Interface to Terminal or Peripheral Device

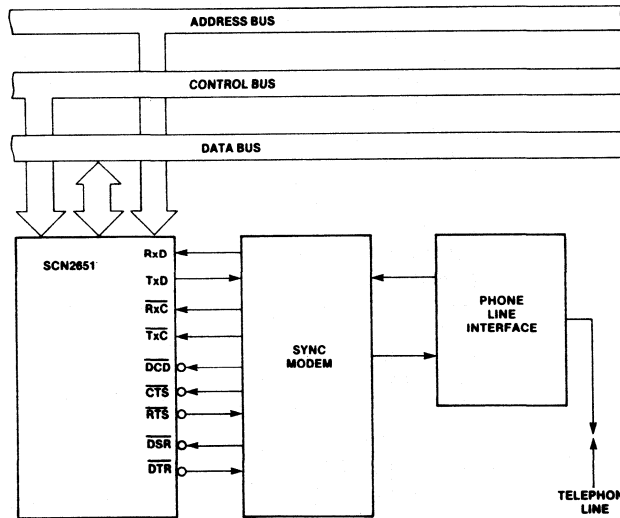

AF008405

Synchronous Interface to Telephone Lines

# SCN2652/SCN68652

## Multi-Protocol Communications Controller (MPCC)

Product Specification

### Microprocessor Products

#### DESCRIPTION

The SCN2652/68652 Multi-Protocol Communications Controller (MPCC) is a monolithic n-channel MOS LSI circuit that formats, transmits and receives synchronous serial data while supporting bit-oriented or byte control protocols. The chip is TTL compatible, operates from a single +5V supply, and can interface to a processor with an 8 or 16-bit bidirectional data bus.

#### FEATURES

- DC to 1Mbps or 2Mbps data rate
- Bit-oriented protocols (BOP): SDLC, ADCCP, HDLC
- Byte-control protocols (BCP): DDCMP, BISYNC (external CRC)
- Programmable operation
  - 8- or 16-bit 3-State data bus
  - Error control - CRC or VRC or none
  - Character length - 1 to 8 bits for BOP or 5 to 8 bits for BCP
  - SYNC or secondary station address comparison for BCP-BOP
  - Idle transmission of SYNC/FLAG or MARK for BCP-BOP
- Automatic detection and generation of special BOP control sequences, i.e., FLAG, ABORT, GA
- Zero insertion and deletion for BOP
- Short character detection for last BOP data character
- SYNC generation, detection, and stripping for BCP
- Maintenance mode for self-testing
- TTL compatible
- Single +5V supply

#### APPLICATIONS

- Intelligent terminals
- Line controllers
- Network processors
- Front end communications
- Remote data concentrators
- Communication test equipment
- Computer to computer links

#### PIN CONFIGURATIONS

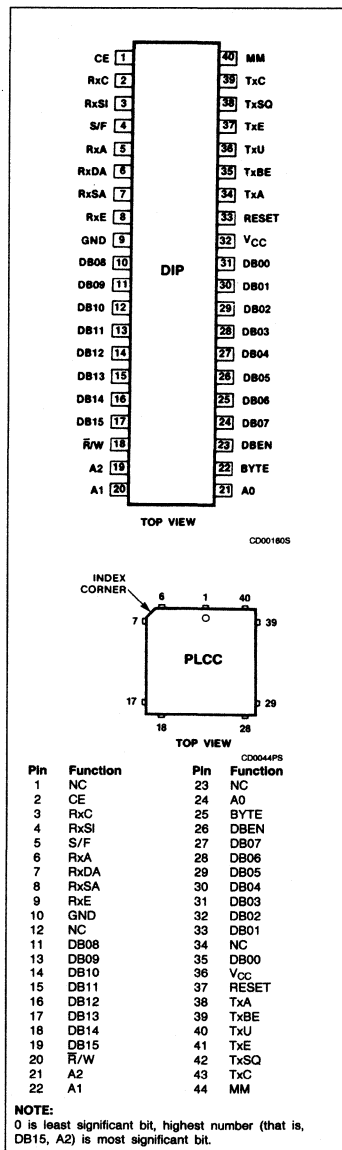

# Multi-Protocol Communications Controller (MPCC)    SCN2652/SCN68652

2

## ORDERING INFORMATION

PACKAGES		V <sub>CC</sub> = 5V ± 5%		
		Commercial	Automotive	Extended
		0°C to +70°C	-40°C to +85°C	-55°C to +125°C
Ceramic DIP	1MHz	SCN2652AC1140	Contact Factory	Contact Factory
	2MHz	SCN2652AC2140	Contact Factory	Contact Factory
Plastic DIP	1MHz	SCN2652AC1N40	Contact Factory	Not Available
	2MHz	SCN2652AC2N40	Contact Factory	Not Available
Plastic LCC	1MHz	SCN2652AC1A44	Contact Factory	Not Available
	2MHz	SCN2652AC2A44	Contact Factory	Not Available

**NOTE:**  
SCN68652 is identical to SCN2652. Order using part numbers shown above.

## BLOCK DIAGRAM

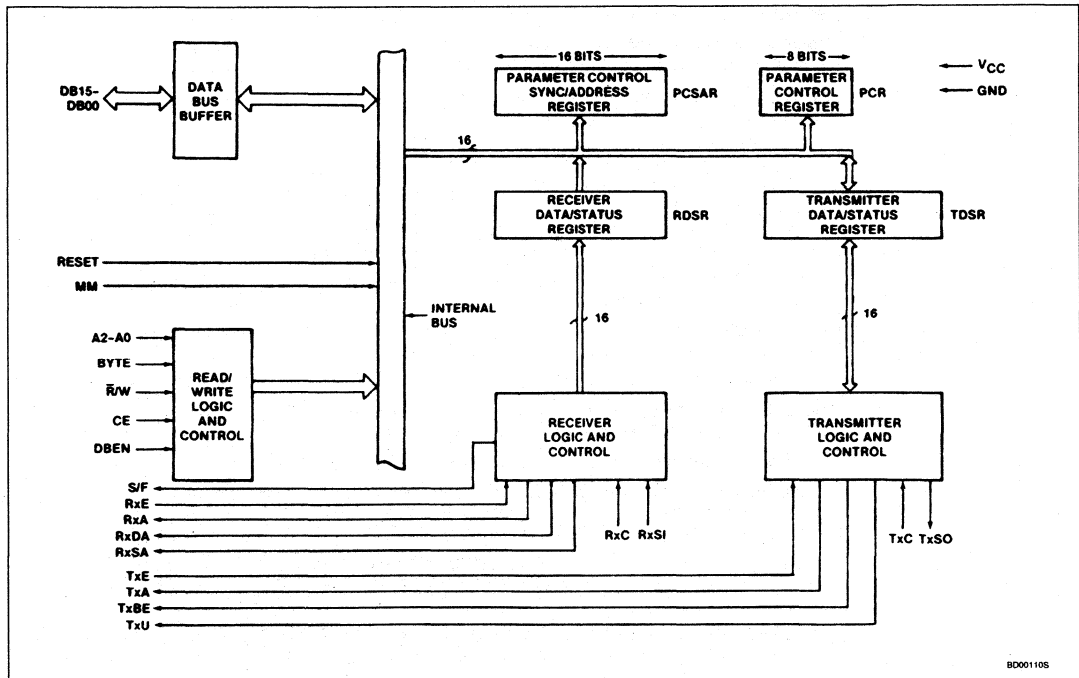

# Multi-Protocol Communications Controller (MPCC)    SCN2652/SCN68652

## PIN DESCRIPTION

MNEMONIC	PIN NO.	TYPE	NAME AND FUNCTION
DB15 – DB00	17 – 10 24 – 31	I/O	<b>Data Bus:</b> DB07 – DB00 contain bidirectional data while DB15 – DB08 contain control and status information to or from the processor. Corresponding bits of the high and low order bytes can be wire OR'ed onto an 8-bit bus. The data bus is floating if either CE or DBEN are low.
A2 – A0	19 – 21	I	<b>Address Bus:</b> A2 – A0 select internal registers. The four 16-bit registers can be addressed on a word or byte basis. See Register Address section.
BYTE	22	I	<b>Byte:</b> Single byte (8-bit) data bus transfers are specified when this input is high. A low-level specifies 16-bit data bus transfers.
CE	1	I	<b>Chip Enable:</b> A high input permits a data bus operation when DBEN is activated.
$\bar{R}/W$	18	I	<b>Read/Write:</b> $\bar{R}/W$ controls the direction of data bus transfer. When high, the data is to be loaded into the addressed register. A low input causes the contents of the addressed register to be presented on the data bus.
DBEN	23	I	<b>Data Bus Enable:</b> After A2 – A0, CE, BYTE and $\bar{R}/W$ are set up, DBEN may be strobed. During a read, the 3-State data bus (DB) is enabled with information for the processor. During a write, the stable data is loaded into the addressed register and TxBE will be reset if TDSR was addressed.
RESET	33	I	<b>Reset:</b> A high-level initializes all internal registers (to zero) and timing.
MM	40	I	<b>Maintenance Mode:</b> MM internally gates TxSO back to RxSI and TxC to RxC for off line diagnostic purposes. The RxC and RxSI inputs are disabled and TxSO is high when MM is asserted.
RxE	8	I	<b>Receiver Enable:</b> A high-level input permits the processing of RxSI data. A low-level disables the receiver logic and initializes all receiver registers and timing.
RxA	5	O	<b>Receiver Active:</b> RxA is asserted when the first data character of a message is ready for the processor. In the BOP mode this character is the address. The received address must match the secondary station address if the MPCC is a secondary station. In BCP mode, if strip-SYNC (PCSAR <sub>13</sub> ) is set, the first non-SYNC character is the first data character; if strip-SYNC is zero, the character following the second SYNC is the first data character. In the BOP mode, the closing FLAG resets RxA. In the BCP mode, RxA is reset by a low level at RxE.
RxDA*	6	O	<b>Receiver Data Available:</b> RxDA is asserted when an assembled character is in RDSR <sub>L</sub> and is ready to be presented to the processor. This output is reset when RDSR <sub>L</sub> is read.
RxC	2	I	<b>Receiver Clock:</b> RxC (1X) provides timing for the receiver logic. The positive going edge shifts serial data into the RxSR from RxSI.
S/F	4	O	<b>SYNC/FLAG:</b> S/F is asserted for one RxC clock time when a SYNC or FLAG character is detected.
RxSA*	7	O	<b>Receiver Status Available:</b> RxSA is asserted when there is a zero to one transition of any bit in RDSR <sub>H</sub> except for RSOM. It is cleared when RDSR <sub>H</sub> is read.
RxSI	3	I	<b>Receiver Serial Input:</b> RxSI is the received serial data. Mark = '1', space = '0'.
TxE	37	I	<b>Transmitter Enable:</b> A high-level input enables the transmitter data path between TDSR <sub>L</sub> and TxSO. At the end of a message, a low-level input causes TxSO = 1(mark) and TxA = 0 after the closing FLAG (BOP) or last character (BCP) is output on TxSO.
TxA	34	O	<b>Transmitter Active:</b> TxA is asserted after TSOM (TDSR <sub>0</sub> ) is set and TxE is raised. This output will reset when TxE is low and the closing FLAG (BOP) or last character (BCP) has been output on TxSO.
TxBE*	35	O	<b>Transmitter Buffer Empty:</b> TxBE is asserted when the TDSR is ready to be loaded with new control information or data. The processor should respond by loading the TDSR which resets TxBE.
TxU*	36	O	<b>Transmitter Underrun:</b> TxU is asserted during a transmit sequence when the service of TxBE has been delayed for one character time. This indicates the processor is not keeping up with the transmitter. Line fill depends on PCSAR <sub>11</sub> . TxU is reset by RESET or setting of TSOM (TDSR <sub>0</sub> ), synchronized by the falling edge of TxC.
TxC	39	I	<b>Transmitter Clock:</b> TxC (1X) provides timing for the transmitter logic. The positive going edge shifts data out of the TxSR to TxSO.
TxSO	38	O	<b>Transmitter Serial Output:</b> TxSO is the transmitted serial data. Mark = '1', space = '0'.
V <sub>CC</sub>	32	I	<b>+5V:</b> Power supply.
GND	9	I	<b>Ground:</b> 0V reference ground.

### NOTE:

\*Indicates possible interrupt signal

# Multi-Protocol Communications Controller (MPCC) SCN2652/SCN68652

**Table 1. Glossary**

REGISTERS		NO. OF BITS	DESCRIPTION*
<b>Addressable</b>			
PCSAR	Parameter control sync/ address register	16	PCSAR <sub>H</sub> and PCR contain parameters common to the receiver and transmitter. PCSAR <sub>L</sub> contains a programmable SYNC character (BCP) or secondary station address (BOP).
PCR	Parameter control register	8	
RDSR	Receive data/status register	16	RDSR <sub>H</sub> contains receiver status information. RDSR <sub>L</sub> = RxDB contains the received assembled character.
TDSR	Transmit data/status register	16	TDSR <sub>H</sub> contains transmitter command and status information. TDSR <sub>L</sub> = TxDB contains the character to be transmitted.
<b>Internal</b>			
CCSR	Control character shift register	8	These registers are used for character assembly (CCSR, HSR, RxSR), disassembly (TxSR), and CRC accumulation/generation (RxCRC, TxCRC).
HSR	Holding shift register	16	
RxSR	Receiver shift register	8	
TxSR	Transmitter shift register	8	
RxCRC	Receiver CRC accumulation register	16	
TxCRC	Transmitter CRC generation register	16	

**NOTES:**

\*H = High byte - bits 15-8  
L = Low byte - bits 7-0

**FUNCTIONAL DESCRIPTION**

The MPCC can be functionally partitioned into receiver logic, transmitter logic, registers that can be read or loaded by the processor, and data bus control circuitry. The register bit formats are shown in Figure 1 while the receiver and transmitter data paths are depicted in Figures 2 and 3.

**Table 2. Error Control**

CHARACTER	DESCRIPTION
FCS	Frame check sequence is transmitted/received as 16 bits following the last data character of a BOP message. The divisor is usually CRC-CCITT ( $X^{16} + X^{12} + X^5 + 1$ ) with dividend preset to 1's but can be other wise determined by ECM. The inverted remainder is transmitter as the FCS.
BCC	Block check character is transmitted/received as two successive characters following the last data character of a BCP message. The polynomial is CRC-16 ( $X^{16} + X^{15} + X^2 + 1$ ) or CRC-CCITT with dividend preset to 0's (as specified by ECM). The true remainder is transmitted as the BCC.

**Table 3. Special Characters**

OPERATION	BIT PATTERN	FUNCTION
BOP	01111110	Frame message
FLAG	11111111 generation	Terminate communication
ABORT	01111111 detection	
GA	01111111	Terminate loop mode
Address	(PCSAR <sub>L</sub> ) <sup>1</sup>	repeater function
BCP	(PCSAR <sub>L</sub> ) or (TxDB) <sup>2</sup>	Secondary station address
SYNC		

**NOTES:**

- ( ) = contents of.
- For IDLE = 0 or 1 respectively.

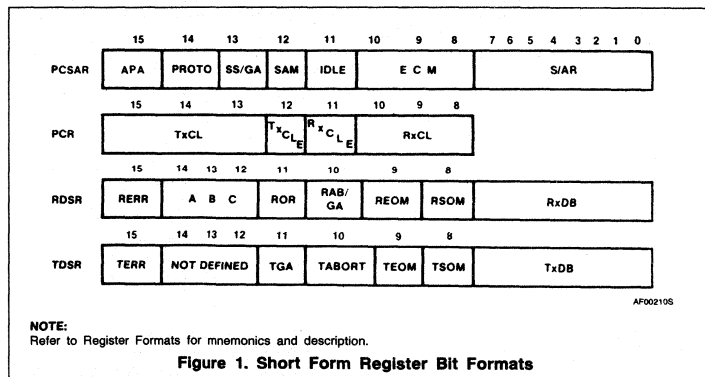

**NOTE:**  
Refer to Register Formats for mnemonics and description.

**Figure 1. Short Form Register Bit Formats**

# Multi-Protocol Communications Controller (MPCC) SCN2652/SCN68652

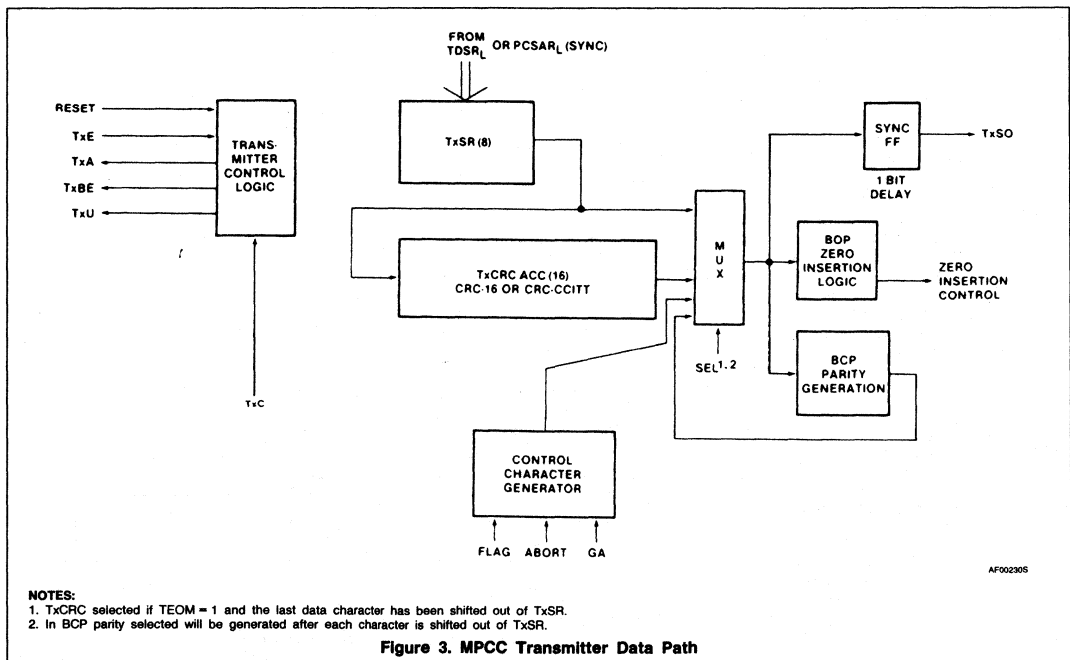
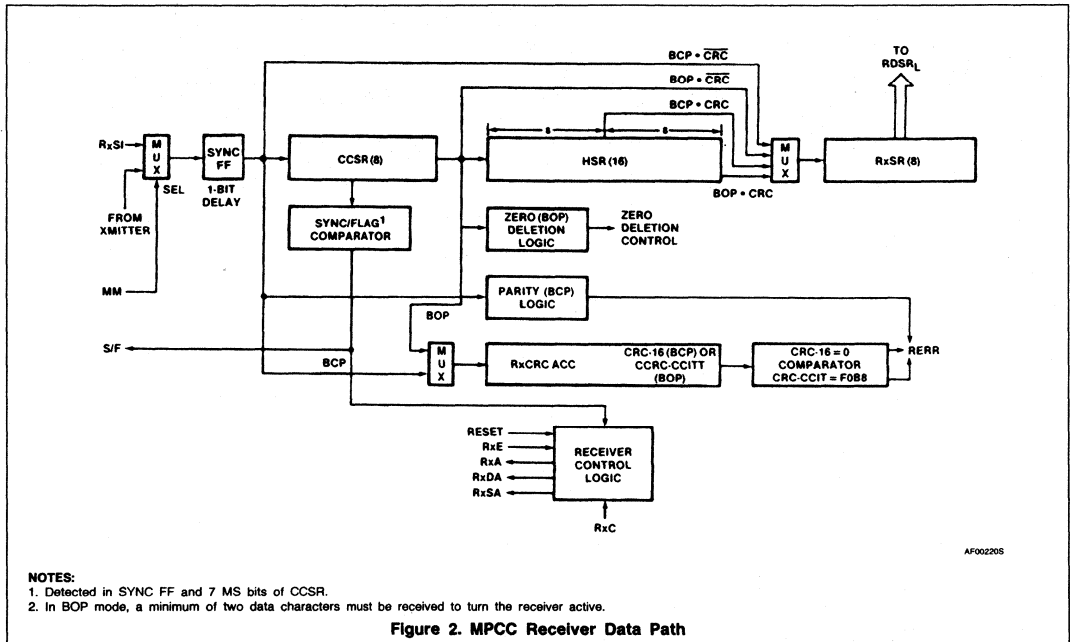



## Multi-Protocol Communications Controller (MPCC) SCN2652/SCN68652

## RECEIVER OPERATION

## General

After initializing the parameter control registers (PCSAR and PCR), the Rx<sub>E</sub> input must be set high to enable the receiver data path. The serial data on the RxSI is synchronized and shifted into an 8-bit Control Character Shift Register (CCSR) on the rising edge of Rx<sub>C</sub>. A comparison between CCSR contents and the FLAG (BOP) or SYNC (BCP) character is made until a match is found. At that time, the S/F output is asserted for one Rx<sub>C</sub> time and the 16-bit Holding Shift Register (HSR) is enabled. The receiver then operates as described below.

## BOP Operation

A flowchart of receiver operation in BOP mode appears in Figure 4. Zero deletion (after five ones are received) is implemented on the received serial data so that a data character will not be interpreted as a FLAG, ABORT, or GA. Bits following the FLAG are shifted through the CCSR, HSR, and into the Receiver Shift Register (RxSR). A character will be assembled in the RxSR and transferred to the RDSR<sub>L</sub> for presentation to the processor. At that time the Rx<sub>DA</sub> output will be asserted and the processor must take the character no later than one Rx<sub>C</sub> time after the next character is assembled in the RxSR. If not, an overrun (RDSR<sub>11</sub> = 1) will occur and succeeding characters will be lost.

The first character following the FLAG is the secondary station address. If the MPCC is a secondary station (PCSAR<sub>12</sub> = 1), the contents of RxSR are compared with the address stored in PCSAR<sub>L</sub>. A match indicates the forthcoming message is intended for the station; the Rx<sub>A</sub> output is asserted, the character is loaded into RDSR<sub>L</sub>, Rx<sub>DA</sub> is asserted and the Receive Start of Message bit (RSOM) is set. No match indicates that another station is being addressed and the receiver searches for the next FLAG.

If the MPCC is a primary station, (PCSAR<sub>12</sub> = 0), no secondary address check is made; Rx<sub>A</sub> is asserted and RSOM is set once the first non-FLAG character has been loaded into RDSR<sub>L</sub> and Rx<sub>DA</sub> has been asserted. Extended address field can be supported by software if PCSAR<sub>12</sub> = 0.

When the 8 bits following the address character have been loaded into RDSR<sub>L</sub> and Rx<sub>DA</sub> has been asserted, RSOM will be cleared. The processor should read this 8-bit character and interpret it as the Control field.

Received serial data that follows is read and interpreted as the information field by the processor. It will be assembled into character lengths as specified by PCR<sub>8-10</sub>. As before, Rx<sub>DA</sub> is asserted each time a character has been transferred into RDSR<sub>L</sub> and is cleared

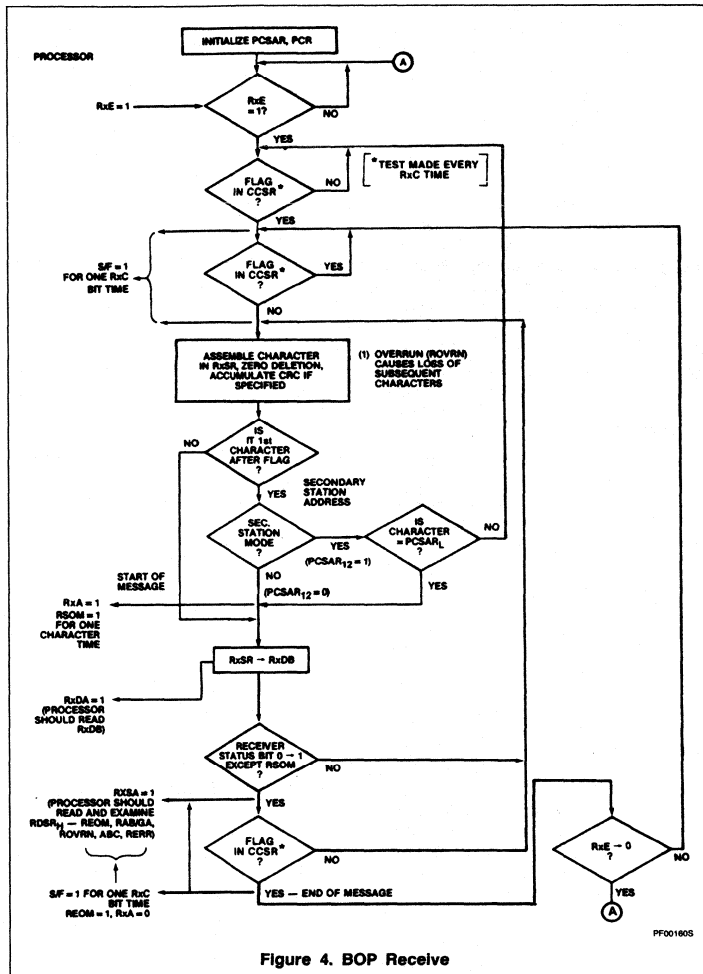

Figure 4. BOP Receive

when RDSR<sub>L</sub> is read by the processor. RDSR<sub>H</sub> should only be read when Rx<sub>SA</sub> is asserted. This occurs on a zero to one transition of any bit in RDSR<sub>H</sub> except for RSOM. Rx<sub>SA</sub> and all bits in RDSR<sub>H</sub> except RSOM are cleared when RDSR<sub>9</sub> is read. The processor should check RDSR<sub>9-15</sub> each time Rx<sub>SA</sub> is asserted. If RDSR<sub>9</sub> is set, then RDSR<sub>12-15</sub> should be examined.

Receiver character length may be changed dynamically in response to Rx<sub>DA</sub>: read the character in Rx<sub>DB</sub> and write the new character length into Rx<sub>CL</sub>. The character length will be changed on the next receiver character boundary. A received residual (short) character will be transferred into Rx<sub>DB</sub> after the

previous character in Rx<sub>DB</sub> has been read, i.e. there will not be an overrun. In general the last two characters are protected from overrun.

The CRC-CCITT, if specified by PCSAR<sub>8-10</sub>, is accumulated in Rx<sub>CRC</sub> on each character following the FLAG. When the closing FLAG is detected in the CCSR, the received CRC is in the 16-bit HSR. At that time, the Receive End of Message bit (REOM) will be set; Rx<sub>SA</sub> and Rx<sub>DA</sub> will be asserted. The processor should read the last data character in RDSR<sub>L</sub> and the receiver status in RDSR<sub>9-15</sub>. If RDSR<sub>15</sub> = 1, there has been a transmission error; the accumulated CRC-CCITT is incorrect. If RDSR<sub>12-14</sub> ≠ 0, the last data charac-

# Multi-Protocol Communications Controller (MPCC) SCN2652/SCN68652

ter is not of prescribed length. Neither the received CRC nor closing FLAG are presented to the processor. The processor may drop RxE or leave it active at the end of the received message.

## BCP Operation

The operation of the receiver in BCP mode is shown in Figure 5. The receiver initially searches for two successive SYNC characters, of length specified by  $PCR_{8-10}$ , that match the contents of  $PCSAR_L$ . The next non-SYNC character or next SYNC character, if stripping is not specified ( $PCSAR_{13} = 0$ ), causes  $RxA$  to be asserted and enables the receiver data path. Once enabled, all characters are assembled in  $RxSR$  and loaded into  $RDSR_L$ .  $RxDA$  is active when a character is available in  $RDSR_L$ .  $RxSA$  is active on a 0 to 1 transition of any bit in  $RDSR_H$ . The signals are cleared when  $RDSR_L$  or  $RDSR_H$  are read respectively.

If CRC-16 error control is specified by  $PCSAR_{8-10}$ , the processor must determine the last character received prior to the CRC field. When that character is loaded into  $RDSR_L$  and  $RxDA$  is asserted, the received CRC will be in  $CCSR$  and  $HSR_L$ . To check for a transmission error, the processor must read the receiver status ( $RDSR_H$ ) and examine  $RDSR_{15}$ . This bit will be set for one character time if an error free message has been received. If  $RDSR_{15} = 0$ , the CRC-16 is in error. The state of  $RDSR_{15}$  in BCP CRC mode does not set  $RxSA$ . Note that this bit should be examined only at the end of a message. The accumulated CRC will include all characters starting with the first non-SYNC character if  $PCSAR_{13} = 1$ , or the character after the opening two SYNCs if  $PCSAR_{13} = 0$ . This necessitates external CRC generation/checking when supporting IBM's BISYNC. This can be accomplished using the Signetics SCN2653 Polynomial Generator/Checker (see Typical Applications).

If VRC has been selected for error control, parity (odd or even) is regenerated on each character and checked when the parity bit is received. A discrepancy causes  $RDSR_{15}$  to be set and  $RxSA$  to be asserted. This must be sensed by the processor. The received parity bit is stripped before the character is presented to the processor.

When the processor has read the last character of the message, it should drop  $RxE$  which disables the receiver logic and initializes all receiver registers and timing.

## TRANSMITTER OPERATION

### General

After the parameter control registers ( $PCSAR$  and  $PCR$ ) have been initialized,  $TxSO$  is held at mark until  $TSOM$  ( $TDSR_8$ ) is set and  $TxE$  is December 12, 1986

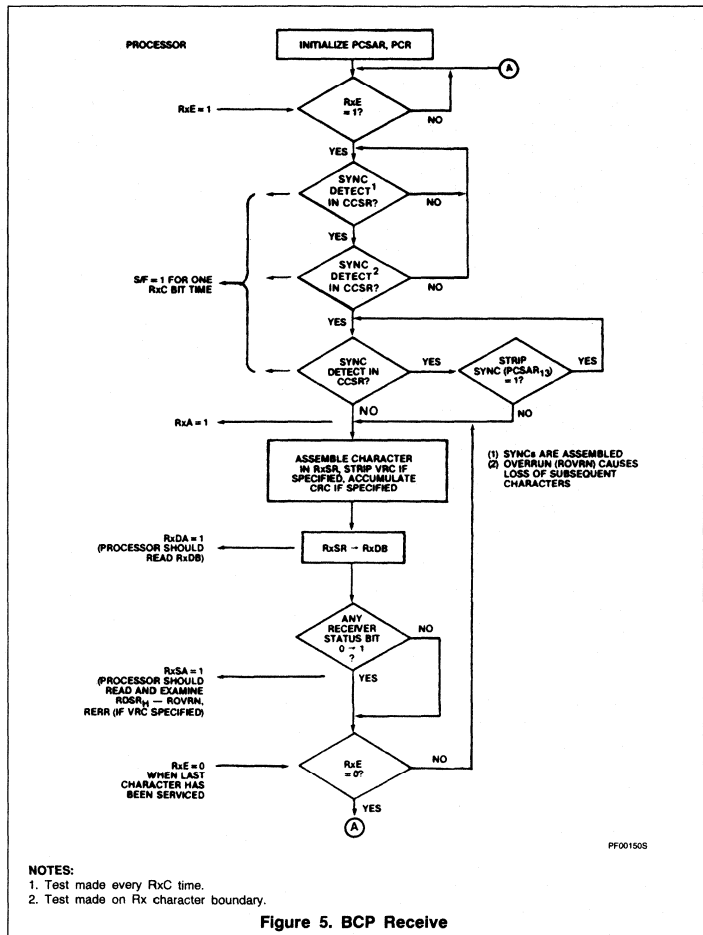

Figure 5. BCP Receive

raised. Then, transmitter operation depends on protocol mode.

## BOP Operation

Transmitter operation for BOP is shown in Figure 6. A FLAG is sent after the processor sets the Transmit Start of Message bit ( $TSOM$ ) and raises  $TxE$ . The FLAG is used to synchronize the message that follows.  $TxA$  will also be asserted. When  $TxBE$  is asserted by the MPCC, the processor should load  $TDSR_L$  with the first character of the message.  $TSOM$  should be cleared at the same time  $TDSR_L$  is loaded (16-bit data bus) or immediately thereafter (8-bit data bus). FLAGS are sent as long as  $TSOM = 1$ . For counting the number of FLAGS, the processor should reassert  $TSOM$  in response to the assertion of  $TxBE$ .

All succeeding characters are loaded into  $TDSR_L$  by the processor when  $TxBE = 1$ . Each character is serialized in  $TxSR$  and transmitted on  $TxSO$ . Internal zero insertion logic stuffs a "0" into the serial bit stream after five successive "1s" are sent. This insures a data character will not match a FLAG, ABORT, or GA reserved control character. As each character is transmitted, the Frame Check Sequence (FCS) is generated as specified by Error Control Mode ( $PCSAR_{8-10}$ ). The FCS should be the CRC-CCITT polynomial ( $X^{16} + X^{12} + X^5 + 1$ ) preset to 1s. If an underrun occurs (processor is not keeping up with the transmitter),  $TxU$  and  $TERR$  ( $TDSR_{15}$ ) will be asserted with ABORT or FLAG used as the  $TxSO$  line fill depending on the state of IDLE ( $PCSAR_{11}$ ). The proces-

Multi-Protocol Communications Controller (MPCC) SCN2652/SCN68652

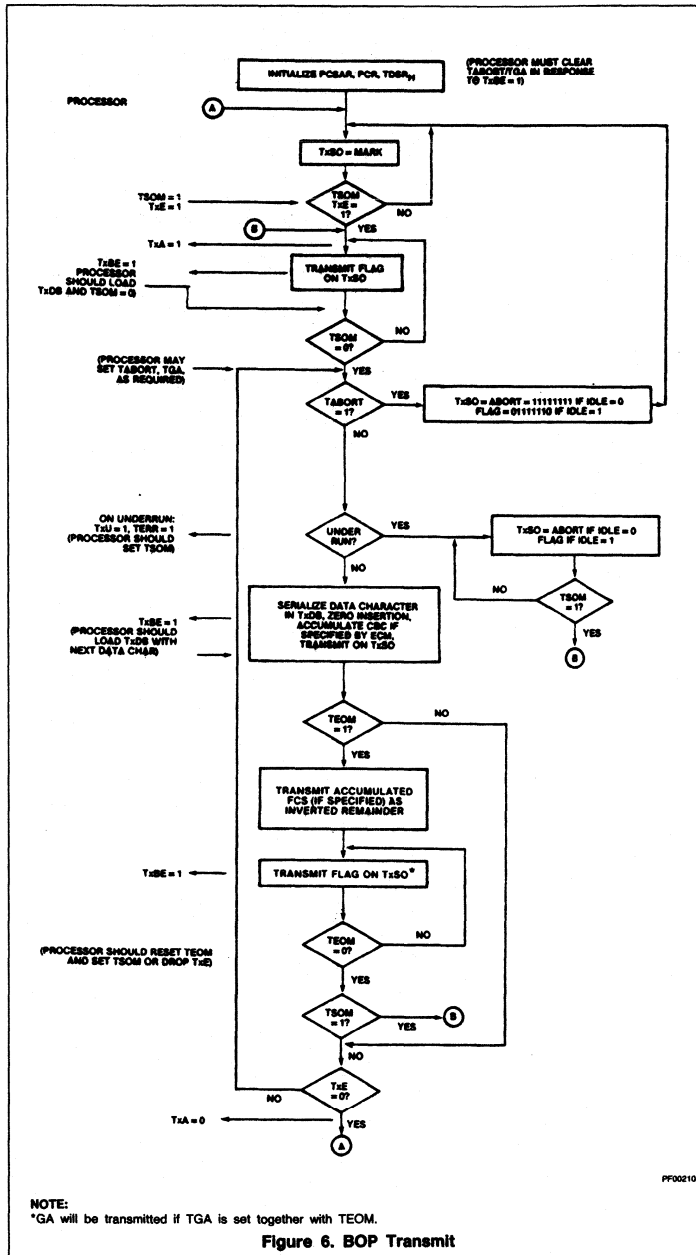

Figure 6. BOP Transmit

Processor must set TSOM to reset the underrun condition. To retransmit the message, the processor should proceed with the normal start of message sequence.

A residual character of 1 to 7 bits may be transmitted at the end of the information field. In response to TxBE, write the residual character length into TxCL and load TxDB with the residual character. Dynamic alteration of character length should be done in exactly the same sequence. The character length will be changed on the next transmit character boundary.

After the last data character has been loaded into TDSR<sub>L</sub> and sent to TxSR (TxBE = 1), the processor should set TEOM (TDSR<sub>9</sub>). The MPCC will finish transmitting the last character followed by the FCS and the closing FLAG. The processor should clear TEOM and drop TxE when the next TxBE is asserted. This corresponds to the start of closing FLAG transmission. When TxE has been dropped, TxA will be low 1 1/2 bit times after the last bit of the closing FLAG has been transmitted. TxSO will be marked after the closing FLAG has been transmitted.

If TxE and TEOM are high, the transmitter continues to send FLAGS. The processor may initiate the next message by resetting TEOM and setting TSOM, or by loading TDSR<sub>L</sub> with a data character and then simply resetting TSOM (without setting TSOM).

**BCP Operation**

Transmitter operation for BCP mode is shown in Figure 7. TxA will be asserted after TSOM = 1 and TxE is raised. At that time SYNC characters are sent from PCSAR<sub>L</sub> or TDSR<sub>L</sub> (IDLE = 0 or 1) as long as TSOM = 1. TxBE is asserted at the start of transmission of the first SYNC character. For counting the number of SYNCs, the processor should reassert TSOM in response to the assertion of TxBE. When TSOM = 0 transmission is from TDSR<sub>L</sub>, which must be loaded with characters from the processor each time TxBE is asserted. If this loading is delayed for more than one character time, an underrun results: TxU and TERR are asserted and the TxSO line fill depend on IDLE (PCSAR<sub>11</sub>). The processor must set TSOM and retransmit the message to recover. This is not compatible with IBM's BISYNC, so that the user must not underrun when supporting that protocol.

CRC-16, if specified by PCSAR<sub>8-10</sub>, is generated on each character transmitted from TDSR<sub>L</sub> when TSOM = 0. The processor must set TEOM = 1 after the last data character has been sent to TxSR (TxBE = 1). The MPCC will finish transmitting the last data character and the CRC-16 field before sending SYNC characters which are transmitted as long as TEOM = 1. If SYNCs are not desired after CRC-16 transmission, the pro-

## Multi-Protocol Communications Controller (MPCC) SCN2652/SCN68652

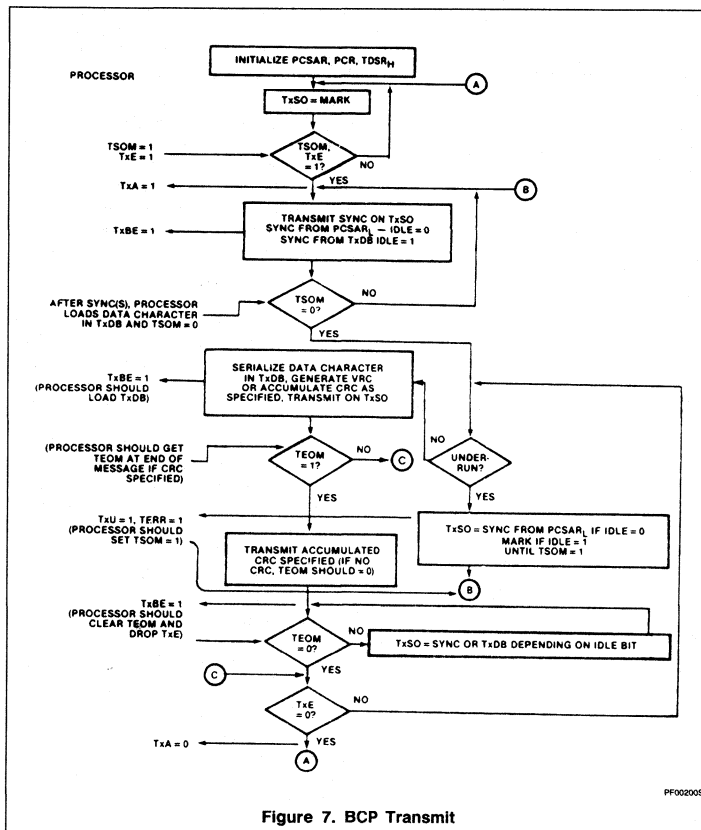

Figure 7. BCP Transmit

cessor should clear TEOM and lower TxE when the TxBE corresponding to the start of CRC-16 transmission is asserted. When TEOM = 0, the line is marked and a new message may be initiated by setting TSOM and raising TxE.

If VRC is specified, it is generated on each data character and the data character length must not exceed 7 bits. For software LRC or

CRC, TEOM should be set only if SYNC's are required at the end of the message block.

### Special Case

The capability to transmit 16 spaces is provided for line turnaround in half duplex mode or for a control recovery situation. This is achieved by setting TSOM and TEOM, clearing TEOM when TxBE = 1, and proceeding as required.

## PROGRAMMING

Prior to initiating data transmission or reception, PCSAR and PCR must be loaded with control information from the processor. The contents of these registers (see Register Format section) will configure the MPCC for the user's specific data communication environment. These registers should be loaded during power-on initialization and after a reset operation. They can be changed at any time that the respective transmitter or receiver is disabled.

The default value for all registers is zero. This corresponds to BOP, primary station mode, 8-bit character length, FCS = CRC-CCITT pre-set to 1's.

For BOP mode the character length register (PCR) may be set to the desired values during system initialization. The address and control fields will automatically be 8-bits. If a residual character is to be transmitted, TxCL should be changed to the residual character length prior to transmission of that character.

## DATA BUS CONTROL

The processor must set up the MPCC register address (A2-A0), chip enable (CE), byte select (BYTE), and read/write ( $\bar{R}/W$ ) inputs before each data bus transfer operation.

During a read operation ( $\bar{R}/W = 0$ ), the leading edge of DBEN will initiate an MPCC read cycle. The addressed register will place its contents on the data bus. If BYTE = 1, the 8-bit byte is placed on DB15-08 or DB07-00 depending on the H/L status of the register addressed. Unused bits in RDSRL are zero. If BYTE = 0, all 16 bits (DB15-00) contain MPCC information. The trailing edge of DBEN will reset RxDA and/or RxSA if RDSRL or RDSRH is addressed respectively.

DBEN acts as the enable and strobe so that the MPCC will not begin its internal read cycle until DBEN is asserted.

During a write operation ( $\bar{R}/W = 1$ ), data must be stable on DB15-08 and/or DB07-00 prior to the leading edge of DBEN. The stable data is strobed into the addressed register by DBEN. TxBE will be cleared if the addressed register was TDSRH or TDSRL.

## Multi-Protocol Communications Controller (MPCC) SCN2652/SCN68652

Table 4. MPCC Register Addressing

A2	A1	A0	REGISTER
<b>BYTE = 0 16-BIT DATA BUS = DB<sub>15</sub> - DB<sub>00</sub></b>			
0	0	X	RDSR
0	1	X	TDSR
1	0	X	PCSAR
1	1	X	PCR*
<b>BYTE = 1 8-BIT DATA BUS = DB<sub>7-0</sub> or DB<sub>15-8</sub>**</b>			
0	0	0	RDSR <sub>L</sub>
0	0	1	RDSR <sub>H</sub>
0	1	0	TDSR <sub>L</sub>
0	1	1	TDSR <sub>H</sub>
1	0	0	PCSAR <sub>L</sub>
1	0	1	PCSAR <sub>H</sub>
1	1	0	PCR <sub>L</sub> *
1	1	1	PCR <sub>H</sub>

## NOTES:

\* PCR lower byte does not exist. It will be all "0"s when read.

\*\* Corresponding high and low order pins must be tied together.

Table 5. Parameter Control Register (PCR) - (R/W)

BIT	NAME	MODE	FUNCTION																																				
00 - 07	Not Defined																																						
08 - 10	RxCL	BOP/BCP	Receiver character length is loaded by the processor when RxCLE = 0. The character length is valid after transmission of single byte address and control fields have been received.  <table border="1"> <thead> <tr> <th>10</th> <th>9</th> <th>8</th> <th>Char length (bits)</th> </tr> </thead> <tbody> <tr><td>0</td><td>0</td><td>0</td><td>8</td></tr> <tr><td>0</td><td>0</td><td>1</td><td>1</td></tr> <tr><td>0</td><td>1</td><td>0</td><td>2</td></tr> <tr><td>0</td><td>1</td><td>1</td><td>3</td></tr> <tr><td>1</td><td>0</td><td>0</td><td>4</td></tr> <tr><td>1</td><td>0</td><td>1</td><td>5</td></tr> <tr><td>1</td><td>1</td><td>0</td><td>6</td></tr> <tr><td>1</td><td>1</td><td>1</td><td>7</td></tr> </tbody> </table>	10	9	8	Char length (bits)	0	0	0	8	0	0	1	1	0	1	0	2	0	1	1	3	1	0	0	4	1	0	1	5	1	1	0	6	1	1	1	7
10	9	8	Char length (bits)																																				
0	0	0	8																																				
0	0	1	1																																				
0	1	0	2																																				
0	1	1	3																																				
1	0	0	4																																				
1	0	1	5																																				
1	1	0	6																																				
1	1	1	7																																				
11	RxCLE	BOP/BCP	Receiver character length enable should be zero when the processor loads RxCL. The remaining bits of PCR are not affected during loading. Always 0 when read.																																				
12	TxCLE	BOP/BCP	Transmitter character length enable should be zero when the processor loads TxCL. The remaining bits of PCR are not affected during loading. Always 0 when read.																																				
13 - 15	TxCL	BOP/BCP	Transmitter character length is loaded by the processor when TxCLE = 0. Character bit length specification format is identical to RxCL. It is valid after transmission of single byte address and control fields.																																				

2

# Multi-Protocol Communications Controller (MPCC)    SCN2652/SCN68652

**Table 6. Parameter Control Sync/Address Register (PCSAR)-(R/W)**

BIT	NAME	MODE	FUNCTION																																																						
00 - 07	S/AR	BOP  BCP	<p>SYNC/address register. Contains the secondary station address if the MPCC is a secondary station. The contents of this register is compared with the first received non-FLAG character to determine if the message is meant for this station.</p> <p>SYNC character is loaded into this register by the processor. It is used for receive and transmit bit synchronization with bit length specified by RxCL and TxCL.</p>																																																						
08 - 10	ECM	BOP/BCP	<table border="1"> <thead> <tr> <th>Error Control Mode</th> <th>10</th> <th>9</th> <th>8</th> <th>Suggested Mode</th> <th>Char. length</th> </tr> </thead> <tbody> <tr> <td>CRC-CCITT preset to 1's</td> <td>0</td> <td>0</td> <td>0</td> <td>BOP</td> <td>1 - 8</td> </tr> <tr> <td>CRC-CCITT preset to 0's</td> <td>0</td> <td>0</td> <td>1</td> <td>BCP</td> <td>8</td> </tr> <tr> <td>Not used</td> <td>0</td> <td>1</td> <td>0</td> <td>—</td> <td></td> </tr> <tr> <td>CRC-16 preset to 0's</td> <td>0</td> <td>1</td> <td>1</td> <td>BCP</td> <td>8</td> </tr> <tr> <td>VRC odd</td> <td>1</td> <td>0</td> <td>0</td> <td>BCP</td> <td>5 - 7</td> </tr> <tr> <td>VRC even</td> <td>1</td> <td>0</td> <td>1</td> <td>BCP</td> <td>5 - 7</td> </tr> <tr> <td>Not used</td> <td>1</td> <td>1</td> <td>0</td> <td>—</td> <td></td> </tr> <tr> <td>No error control</td> <td>1</td> <td>1</td> <td>1</td> <td>BOP/BOP</td> <td>5 - 8</td> </tr> </tbody> </table> <p>ECM should be loaded by the processor during initialization or when both data paths are idle.</p>	Error Control Mode	10	9	8	Suggested Mode	Char. length	CRC-CCITT preset to 1's	0	0	0	BOP	1 - 8	CRC-CCITT preset to 0's	0	0	1	BCP	8	Not used	0	1	0	—		CRC-16 preset to 0's	0	1	1	BCP	8	VRC odd	1	0	0	BCP	5 - 7	VRC even	1	0	1	BCP	5 - 7	Not used	1	1	0	—		No error control	1	1	1	BOP/BOP	5 - 8
Error Control Mode	10	9	8	Suggested Mode	Char. length																																																				
CRC-CCITT preset to 1's	0	0	0	BOP	1 - 8																																																				
CRC-CCITT preset to 0's	0	0	1	BCP	8																																																				
Not used	0	1	0	—																																																					
CRC-16 preset to 0's	0	1	1	BCP	8																																																				
VRC odd	1	0	0	BCP	5 - 7																																																				
VRC even	1	0	1	BCP	5 - 7																																																				
Not used	1	1	0	—																																																					
No error control	1	1	1	BOP/BOP	5 - 8																																																				
11	IDLE	BOP  BCP	<p>Determines line fill character to be used if transmitter underrun occurs (TxU asserted and TERR set) and transmission of special characters for BOP/BCP.</p> <p>IDLE = 0, transmit ABORT characters during underrun and when TABORT = 1. IDLE = 1, transmit FLAG characters during underrun and when TABORT = 1.</p> <p>IDLE = 0 transmit initial SYNC characters and underrun line fill characters from the S/AR. IDLE = 1 transmit initial SYNC characters from TxDB and marks TxSO during underrun.</p>																																																						
12	SAM	BOP	<p>Secondary Address Mode = 1 if the MPCC is a secondary station. This facilitates automatic recognition of the received secondary station address. When transmitting, the processor must load the secondary address into TxDB.</p> <p>SAM = 0 inhibits the received secondary address comparison which serves to activate the receiver after the first non-FLAG character has been received.</p>																																																						
13	SS/GA	BOP  BCP	<p>Strip SYNC/Go Ahead. Operation depends on mode.</p> <p>SS/GA = 1 is used for loop mode only and enables GA detection. When a GA is detected as a closing character, REOM and RAB/GA will be set and the processor should terminate the repeater function. SS/GA = 0 is the normal mode which enables ABORT detection. It causes the receiver to terminate the frame upon detection of an ABORT or FLAG.</p> <p>SS/GA = 1, causes the receiver to strip SYNC's immediately following the first two SYNC's detected. SYNC's in the middle of a message will not be stripped. SS/GA = 0, presents any SYNC's after the initial two SYNC's to the processor.</p>																																																						
14	PROTO	BOP BCP	<p>Determines MPCC Protocol mode</p> <p>PROTO = 0 PROTO = 1</p>																																																						
15	APA	BOP	<p>All parties address. If this bit is set, the receiver data path is enabled by an address field of '11111111' as well as the normal secondary station address.</p>																																																						

# Multi-Protocol Communications Controller (MPCC)    SCN2652/SCN68652

**Table 7. Transmit Data/Status Register (TDSR) (R/W Except TDSR15)**

BIT	NAME	MODE	FUNCTION
00-07	TxDB	BOP/BCP	Transmit data buffer. Contains processor loaded characters to be serialized in TxSR and transmitted on TxSO.
08	TSOM	BOP BCP	Transmitter start of message. Set by the processor to initiate message transmission provided TxE = 1. TSOM = 1 generates FLAGs. When TSOM = 0 transmission is from TxDB and FCS generation (if specified) begins. FCS, as specified by PCSAR <sub>9-10</sub> , should be CRC-CCITT preset to 1's. TSOM = 1 generates SYNCs from PCSAR <sub>L</sub> or transmits from TxDB for IDLE = 0 or 1 respectively. When TSOM = 0 transmission is from TxDB and CRC generation (if specified) begins.
09	TEOM	BOP BCP	Transmit end of message. Used to terminate a transmitted message. TEOM = 1 causes the FCS and the closing FLAG to be transmitted following the transmission of the data character in TxSR. FLAGs are transmitted until TEOM = 0. ABORT or GA are transmitted if TABORT or TGA are set when TEOM = 1. TEOM = 1 causes CRC-16 to be transmitted (if selected) followed by SYNCs from PCSAR <sub>L</sub> or TxDB (IDLE = 0 or 1). Clearing TEOM prior to the end of CRC-16 transmission (when TxBE = 1) causes TxSO to be marked following the CRC-16. TxE must be dropped before a new message can be initiated. If CRC is not selected, TEOM should not be set.
10	TABORT	BOP	Transmitter abort = 1 will cause ABORT or FLAG to be sent (IDLE = 0 or 1) after the current character is transmitted. (ABORT = 11111111)
11	TGA	BOP	Transmit go ahead (GA) instead of FLAG when TEOM = 1. This facilitates repeater termination in loop mode. (GA = 01111111)
12-14	Not Defined		
15	TERR	Read only BOP BCP	Transmitter error = 1 indicates the TxDB has not been loaded in time (one character time- $\frac{1}{2}$ TxC period after TxBE is asserted) to maintain continuous transmission. TxU will be asserted to inform the processor of this condition. TERR is cleared by setting TSOM. See timing diagram. ABORT's or FLAG's are sent as fill characters (IDLE = 0 or 1) SYNC's or MARK's are sent as fill characters (IDLE = 0 or 1). For IDLE = 1 the last character before underrun is not valid.

**2**

# Multi-Protocol Communications Controller (MPCC)    SCN2652/SCN68652

**Table 8. Receiver Data/Status Register (RDSR) – (Read Only)**

BIT	NAME	MODE	FUNCTION
00 – 07	RxDB	BOP/BCP	Receiver data buffer. Contains assembled characters from the RxSR. If VRC is specified, the parity bit is stripped.
08	RSOM	BOP	Receiver start of message = 1 when a FLAG followed by a non-FLAG has been received and the latter character matches the secondary station if SAM = 1. RxA will be asserted when RSOM = 1. RSOM resets itself after one character time and has no affect on RxSA.
09	REOM	BOP	Receiver end of message = 1 when the closing FLAG is detected and the last data character is loaded into RxDB or when an ABORT/GA character is received. REOM is cleared on reading RDSR <sub>H</sub> , reset operation, or dropping of RxE.
10	RAB/GA	BOP	Received ABORT or GA character = 1 when the receiver senses an ABORT character if SS/GA = 0 or a GA character if SS/GA = 1. RAB/GA is cleared on reading RDSR <sub>H</sub> , reset operation, or dropping of RxE. A received abort does not set RxDA.
11	ROR	BOP/BCP	Receiver overrun = 1 indicates the processor has not read last character in the RxDB within one character time + 1/2 RxC period after RxDA is asserted. Subsequent characters will be lost. ROR is cleared on reading RDSR <sub>H</sub> , reset operation, or dropping of RxE.
12 – 14	ABC	BOP	Assembled bit count. Specifies the number of bits in the last received data character of a message and should be examined by the processor when REOM = 1 (RxDA and RxSA asserted). ABC = 0 indicates the message was terminated (by a flag or GA) on a character boundary as specified by PCR <sub>8-10</sub> . Otherwise, ABC = number of bits in the last data character. ABC is cleared when RDSR <sub>H</sub> is read, reset operation, or dropping RxE. The residual character is right justified in RDSR <sub>L</sub> .
15	RERR	BOP/BCP	Receiver error indicator should be examined by the processor when REOM = 1 in BOP, or when the processor determines the last data character of the message in BCP with CRC or when RxSA is set in BCP with VRC. CRC-CCITT preset to 1's/0's as specified by PCSAR <sub>8-10</sub> : RERR = 1 indicates FCS error (CRC ≠ F0B8 or ≠ 0) RERR = 0 indicates FCS received correctly (CRC = F0B8 or = 0) CRC-16 preset to 0's on 8-bit characters specified by PSCAR <sub>8-10</sub> : RERR = 1 indicates CRC-16 received correctly (CRC = 0). RERR = 0 indicates CRC-16 error (CRC ≠ 0) VRC specified by PCSAR <sub>8-10</sub> : RERR = 1 indicates VRC error RERR = 0 indicates VRC is correct.

**ABSOLUTE MAXIMUM RATINGS<sup>1</sup>**

SYMBOL	PARAMETER	RATING	UNIT
T <sub>A</sub>	Operating ambient temperature <sup>2</sup>	Note 4	°C
T <sub>STG</sub>	Storage temperature range	-65 to +150	°C
	Input or output voltages with respect to GND <sup>3</sup>	-0.3 to +15	V
V <sub>CC</sub>	With respect to GND	-0.3 to +7	V



## Multi-Protocol Communications Controller (MPCC) SCN2652/SCN68652

DC ELECTRICAL CHARACTERISTICS<sup>4, 5</sup>

SYMBOL	PARAMETER	TEST CONDITIONS	LIMITS			UNIT
			Min	Typ	Max	
<b>Input voltage</b>						
V <sub>IL</sub> V <sub>IH</sub>	Low High		2		0.8	V
<b>Output voltage</b>						
V <sub>OL</sub> V <sub>OH</sub>	Low High	I <sub>OL</sub> = 1.6mA I <sub>OH</sub> = -100μA	2.4		0.4	V
I <sub>CC</sub>	Power supply current	V <sub>CC</sub> = 5.25V, T <sub>A</sub> = 0°C			150	mA
<b>Leakage current</b>						
I <sub>IL</sub> I <sub>OL</sub>	Input Output	V <sub>IN</sub> = 0 to 5.25V V <sub>OUT</sub> = 0 to 5.25V			10 10	μA
<b>Capacitance</b>						
C <sub>IN</sub> C <sub>OUT</sub>	Input Output	V <sub>IN</sub> = 0V, f = 1MHz V <sub>OUT</sub> = 0V, f = 1MHz			20 20	pF

AC ELECTRICAL CHARACTERISTICS<sup>4, 5, 6</sup>

SYMBOL	PARAMETER	1MHz CLOCK VERSION			2MHz CLOCK VERSION			UNIT
		Min	Typ	Max	Min	Typ	Max	
<b>Setup and hold time</b>								
t <sub>ACS</sub>	Address/control setup	50			50			ns
t <sub>ACH</sub>	Address/control hold	0			0			
t <sub>DS</sub>	Data bus setup (write)	50			50			
t <sub>DH</sub>	Data bus hold (write)	0			0			
t <sub>RXS</sub>	Receiver serial data setup	150			150			
t <sub>RXH</sub>	Receiver serial data hold	150			150			
<b>Pulse width</b>								
t <sub>RES</sub>	RESET	250			250			ns
t <sub>DBEN</sub>	DBEN	250		m <sup>7</sup>	200		m <sup>7</sup>	
<b>Delay Time</b>								
t <sub>DD</sub>	Data bus (read)			200			170	ns
t <sub>TxD</sub>	Transmit serial data			325			250	
t <sub>DBEND</sub>	DBEN to DBEN delay	200			200			
t <sub>DF</sub>	Data bus float time (read)			150			150	ns
f	Clock (RxC,TxC) frequency			1			2	MHz
t <sub>CLK1</sub>	Clock high (MM = 0)	340			165			ns
t <sub>CLK2</sub>	Clock high (MM = 1)	490			240			
t <sub>CLK0</sub>	Clock low	490			240			

## NOTES:

- Stresses above those listed under "Absolute Maximum Ratings" may cause permanent damage to the device. This is a stress rating only and functional operation of the device at these or at any other condition above those indicated in the operation sections of this specification is not implied.
- For operating at elevated temperatures the device must be derated based on +150°C maximum junction temperature.
- This product includes circuitry specifically designed for the protection of its internal devices from the damaging effects of excessive static charge. Nonetheless, it is suggested that conventional precautions be taken to avoid applying any voltages larger than the rated maxima.
- Parameters are valid over operating temperature range unless otherwise specified. See ordering code table for applicable temperature range and operating supply range.
- All voltage measurements are referenced to ground. All time measurements are at 0.8V or 2V. Input voltage levels for testing are 0.4V and 2.4V.
- Output load C<sub>L</sub> = 100pF.
- m = TxC low and applies to writing to TDSR<sub>H</sub> only.

# Multi-Protocol Communications Controller (MPCC) SCN2652/SCN68652

## TIMING DIAGRAMS

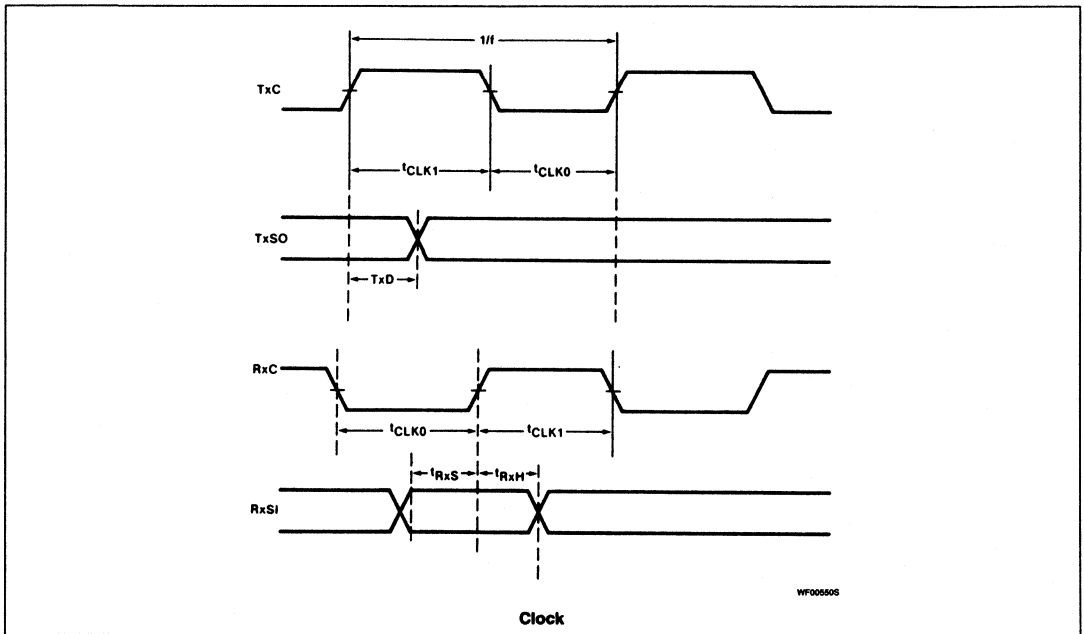
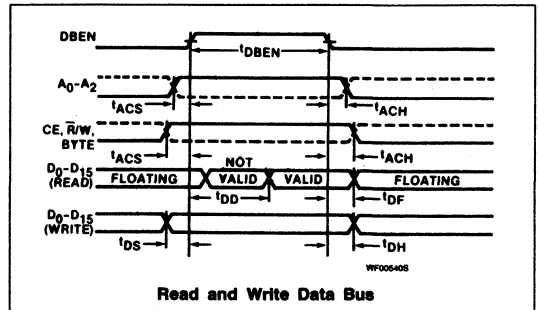
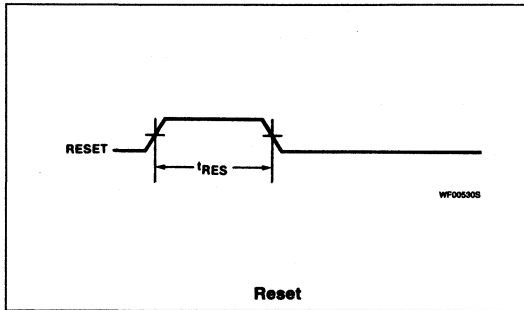

# Multi-Protocol Communications Controller (MPCC) SCN2652/SCN68652

2

## TIMING DIAGRAMS (Continued)

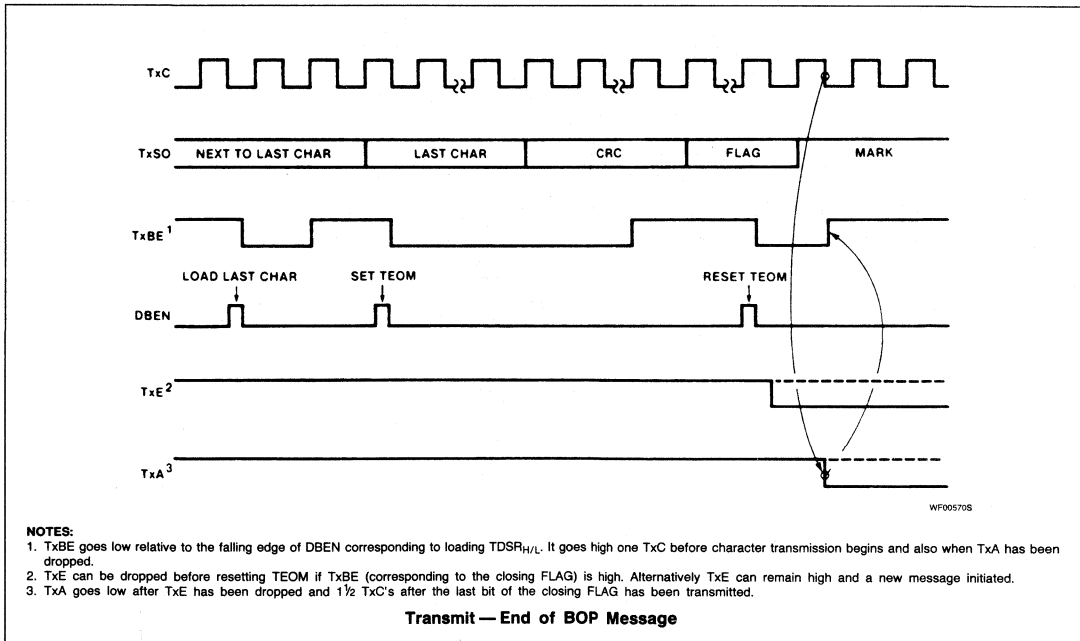
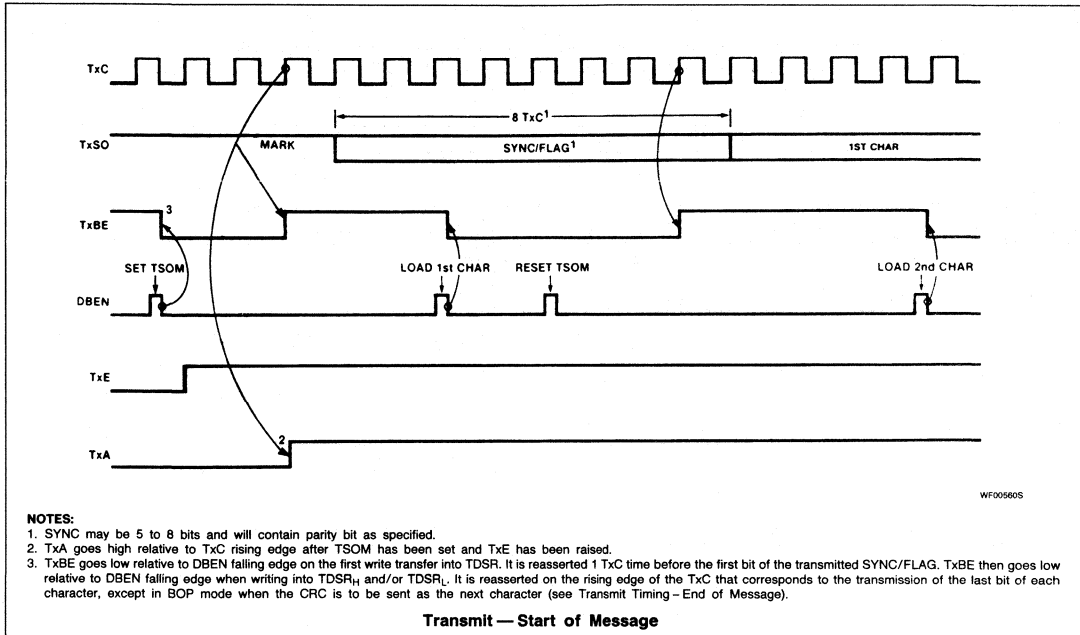

Multi-Protocol Communications Controller (MPCC) SCN2652/SCN68652

TIMING DIAGRAMS (Continued)

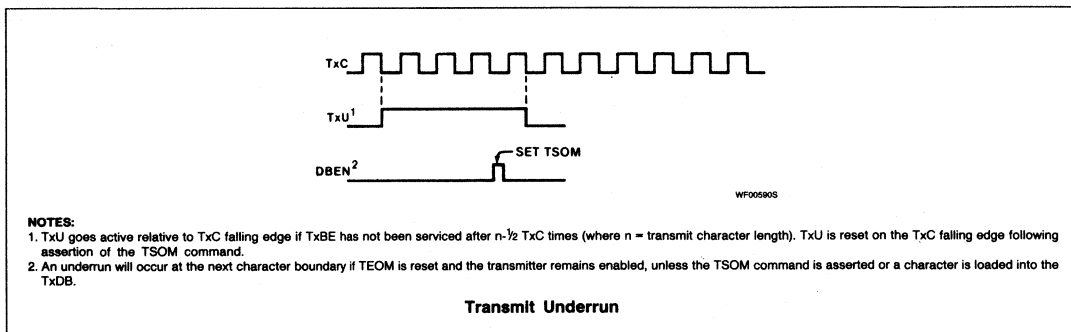
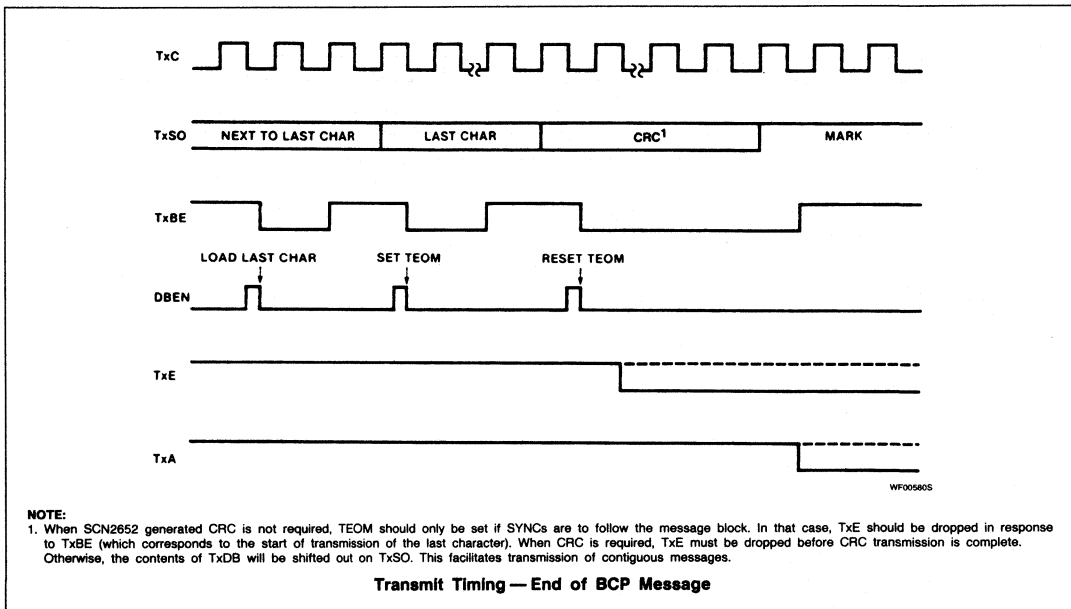

Multi-Protocol Communications Controller (MPCC) SCN2652/SCN68652

2

TIMING DIAGRAMS (Continued)

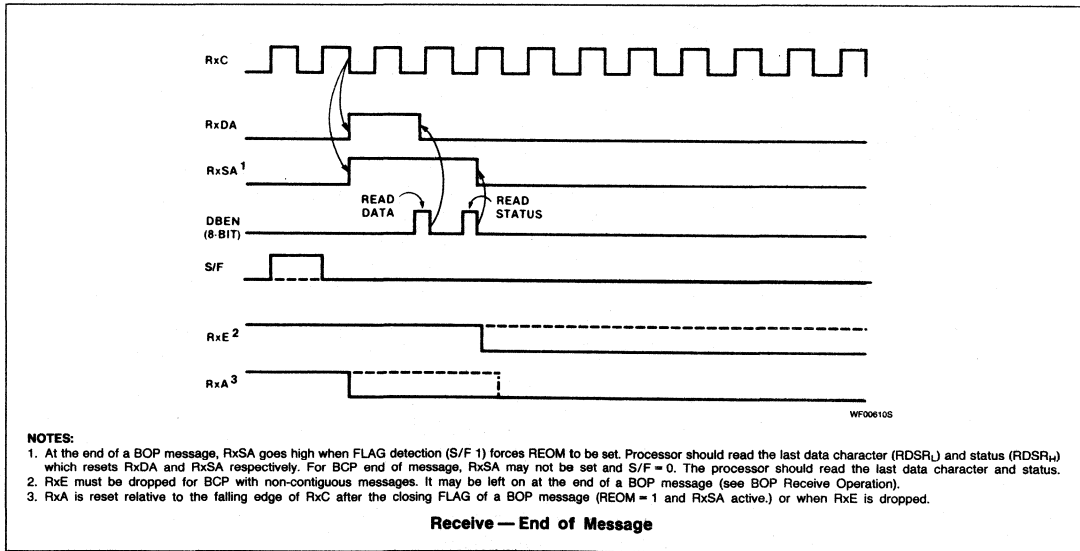
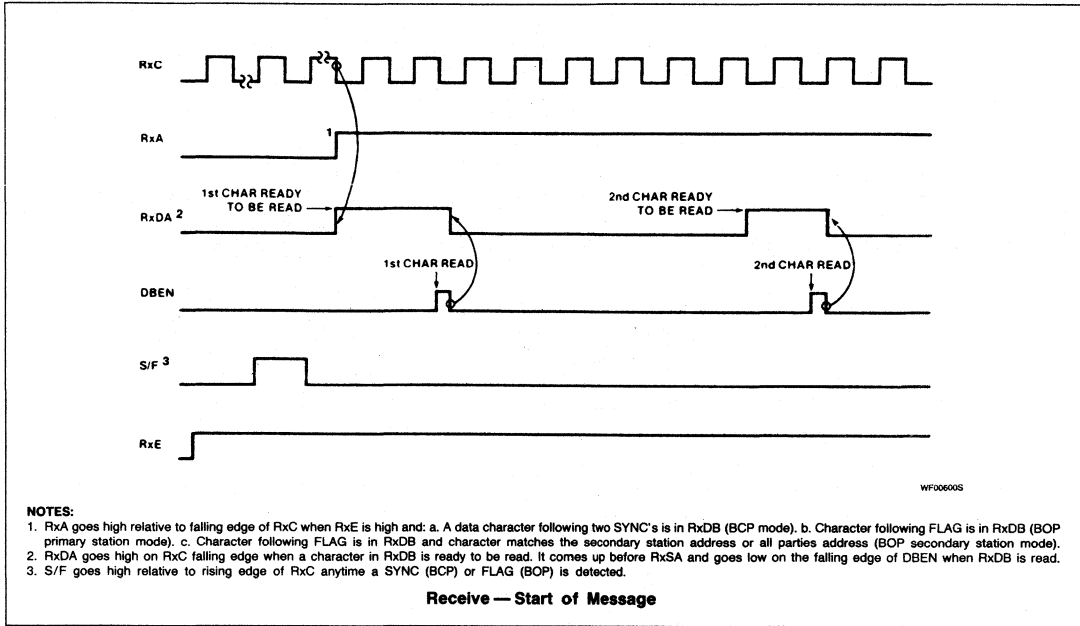

# Multi-Protocol Communications Controller (MPCC) SCN2652/SCN68652

## TYPICAL APPLICATIONS

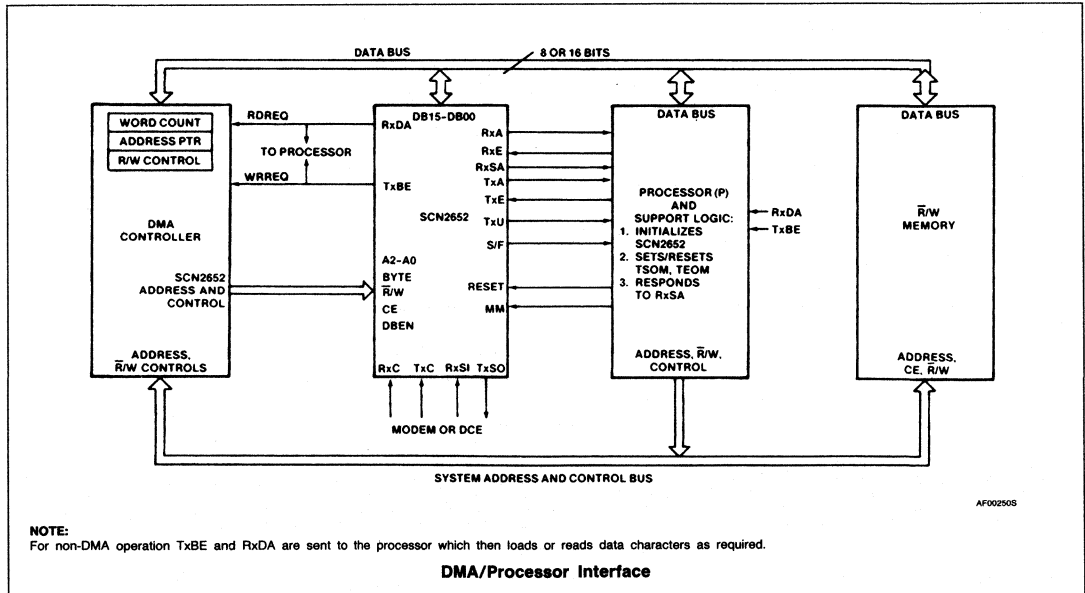
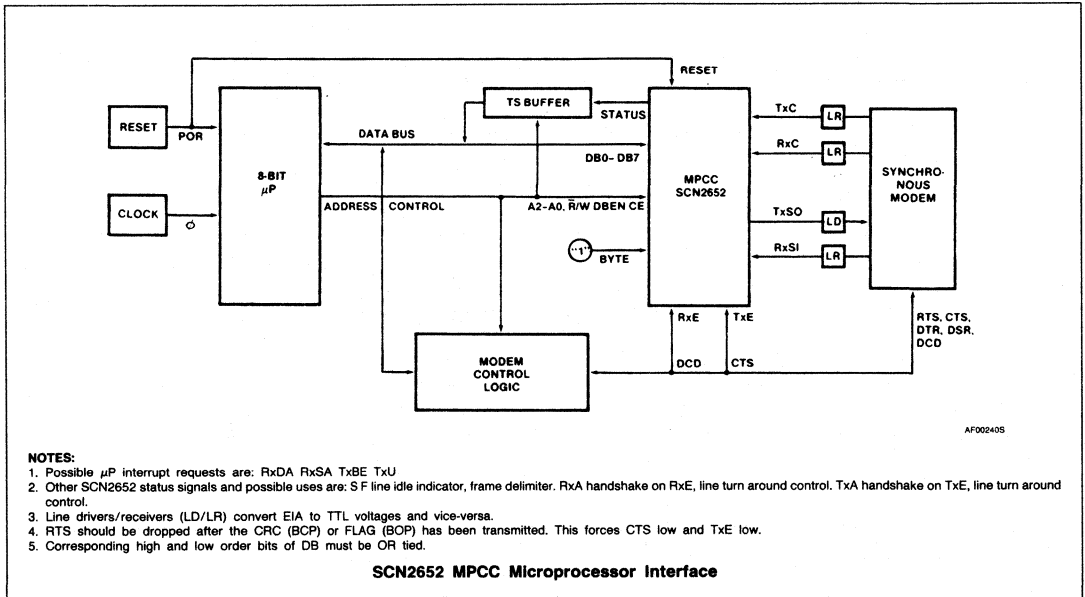

Multi-Protocol Communications Controller (MPCC) SCN2652/SCN68652

2

TYPICAL APPLICATIONS (Continued)

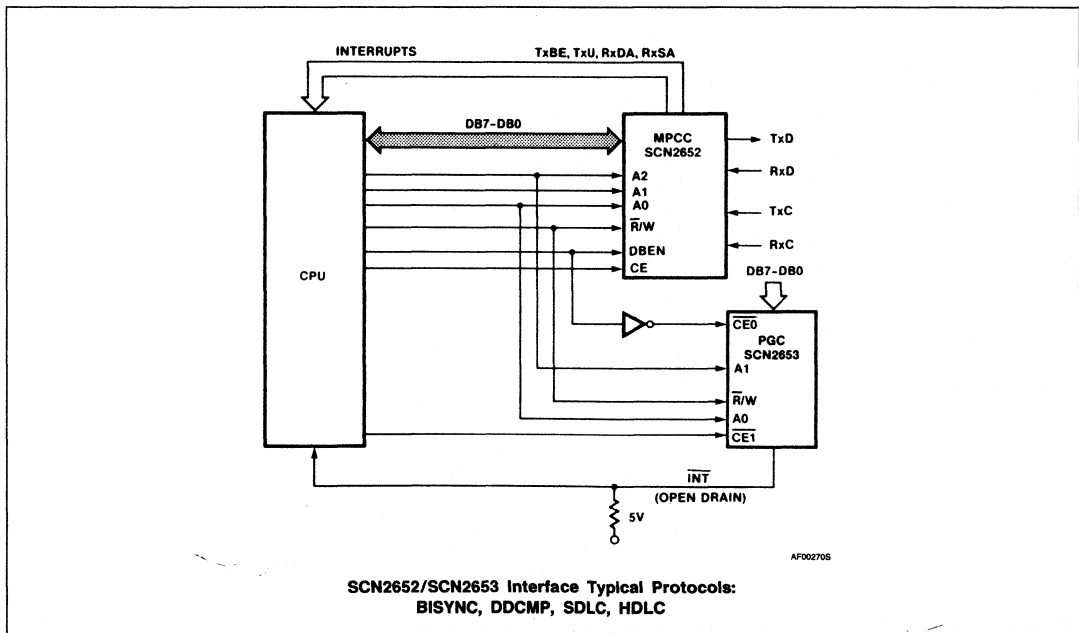
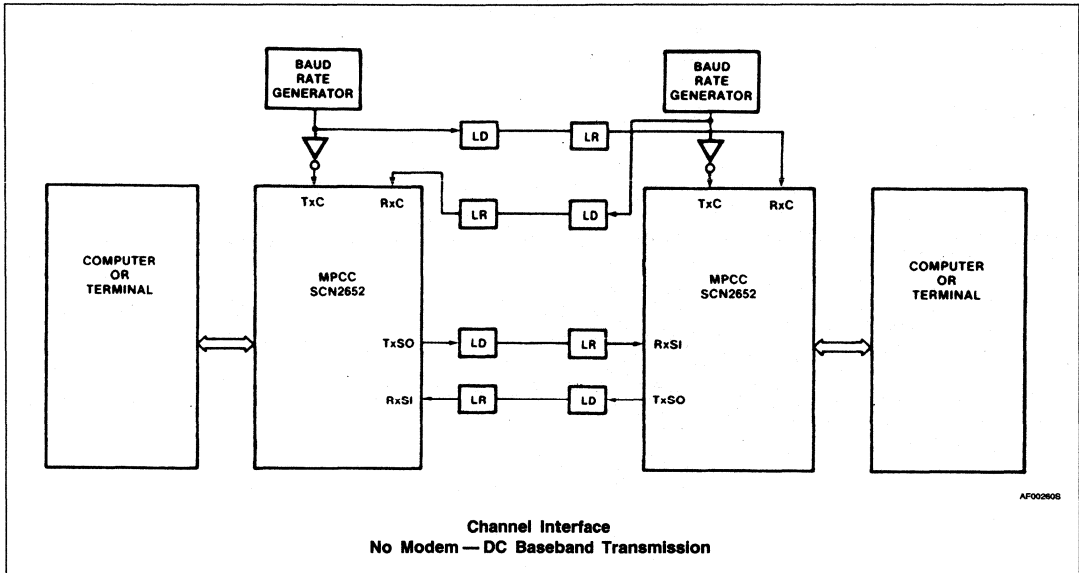

# SCN2653/SCN68653

## Polynomial Generator Checker (PGC)

### Product Specification

#### Microprocessor Products

#### DESCRIPTION

The Signetics SCN2653/68653 Polynomial Generator Checker (PGC) is a polynomial generator checker/character comparator circuit that complements a receiver/transmitter (R/T or USART/USRT/UART) in the support of character oriented data link controls. Table 1 defines many of the more commonly used PGC terms and abbreviations.

Parallel data characters transferred between the CPU and R/T are monitored by the PGC which performs block check character (BCC) and parity (VRC) generation/checking, single character detection, and two character sequence detection. Since the PGC operates on parallel characters, the data transmission format may be serial (synchronous or asynchronous) or parallel.

There are four modes of BCC accumulation and each mode can select one of three polynomials to compute the BCC. In the BISYNC normal and transparent modes, the PGC determines which characters are to be accumulated and which characters are to be excluded from the accumulation. The block terminating characters and the initiation and termination of BISYNC transparent text can be detected and an interrupt generated. The single interrupt output represents the inclusive OR of four maskable status conditions.

In the automatic accumulation mode, all characters are accumulated while the single accumulate mode requires a specific accumulation command for each character to be accumulated.

Character accumulation control and character comparisons are facilitated by a character class array which places each of 128 characters into one of four character classes. The four classes are normal, SYN/BISYNC not included, block terminating character (BTC)/search character (SC), and secondary search character (SSC).

#### FEATURES

- **Parallel Block Check Character accumulation/checking: CRC-16, CRC-12, LRC-8**
- **BISYNC normal and transparent modes**
- **Automatic or single character accumulation modes**
- **Character detection - up to 128 characters**
- **Two character sequence detection; examples: DLE-STX, ACK0, ACK1, WACK, RVI, DISC, WBT**
- **6, 7, or 8-bit characters**
- **VRC generation/checking on data bus**
- **Four maskable interrupt conditions**
- **Four classes of characters**
- **Internal power-on reset**
- **Maximum character accumulation rate of 500kHz (4Mbps)**
- **Directly compatible with Signetics SCN2651, SCN2652 and SCN2661**
- **No system clock required**
- **TTL compatible inputs and outputs**
- **Single 5V supply**
- **16-pin dual in line package**

#### APPLICATIONS

- **Character oriented data link control:**
  - dedicated to one USART/USRT
  - multiplexed among several USART/USRTs
- **Automated BISYNC with 2661 (minimal software intervention)**
- **BCC and VRC generation/detection on a block of memory or peripheral data**
- **Programmable character array comparator**

#### PIN CONFIGURATION

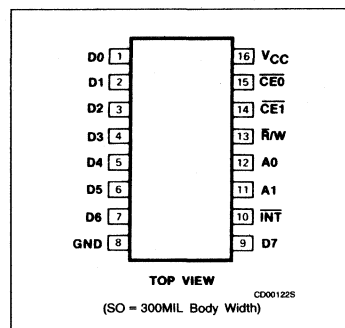



## Polynomial Generator Checker (PGC)

SCN2653/SCN68653

## ORDERING INFORMATION

PACKAGES	$V_{CC} = 5V \pm 5\%$ , $T_A = 0^\circ C$ to $+70^\circ C$
Ceramic DIP	SCN2653AC4116
Plastic DIP	SCN2653AC4N16
Small Outline (SO)	SCN2653ACD16

## NOTE:

SCN68653 is identical to SCN2653. Order using numbers shown above.

## BLOCK DIAGRAM

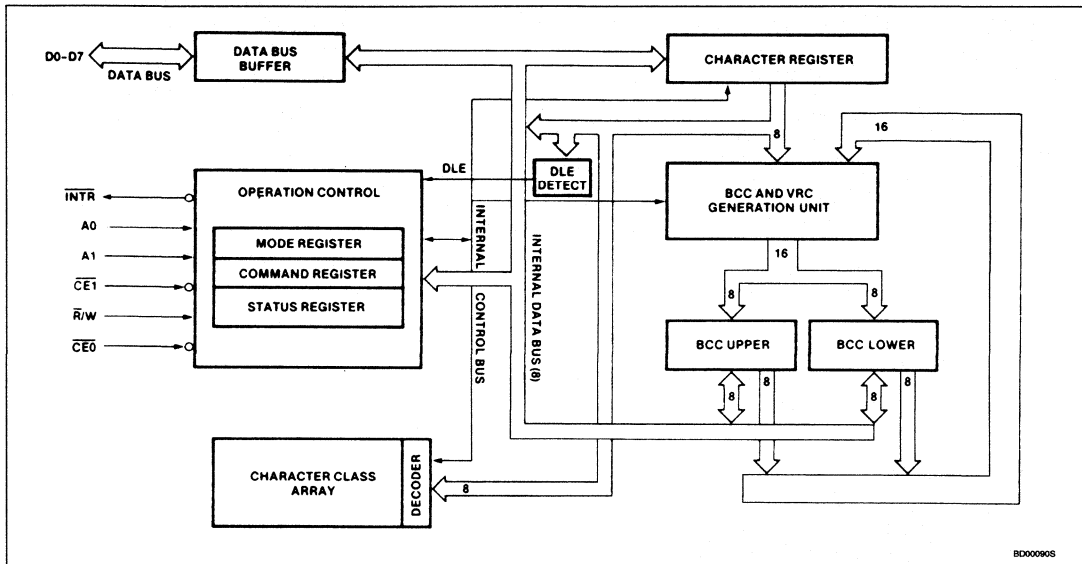

## PIN DESCRIPTION

MNEMONIC	PIN NO.	TYPE	NAME AND FUNCTION
$V_{CC}$	16	I	<b>+5V:</b> Power supply
GND	8	I	Ground
A1-A0	11,12	I	<b>Address Lines:</b> Used to select internal PGC registers or character class array.
$\bar{R}/\bar{W}$	13	I	<b>Read/Write:</b> Read command when low, write command when high.
$\overline{CE0}$	15	I	<b>Chip Enable:</b> Connected to chip enable input of a receiver/transmitter (R/T) circuit. It is used to strobe data being transferred between the CPU and the R/T into the PGC character register.
$\overline{CE1}$	14	I	<b>Chip Enable:</b> Used in conjunction with the $\bar{R}/\bar{W}$ signal to enable the transfer of data between the PGC and the CPU or DMA controller and to initialize the PGC registers.
D7-D0	9,7-1	I/O	<b>Data Bus:</b> 8-bit 3-State bidirectional bus used to transfer data to or from the PGC via $\overline{CE0}$ or $\overline{CE1}$ . All data, mode words, command words, and status information are transferred on this bus. D0 is the least significant bit; D7 is the most significant bit.
$\bar{INT}$	10	O	<b>Interrupt:</b> Open drain active low interrupt output that signals the CPU that one or more maskable conditions are true: BCC error, VRC error, BTC/SC detect, SSC detect. The true conditions can be determined by reading the status register which in turn deactivates $\bar{INT}$ . A power on, clear BCC, or master reset command causes $\bar{INT}$ to be inactive (high).

## Polynomial Generator Checker (PGC)

SCN2653/SCN68653

Additional PGC applications include off-line R/T operation where the BCC is generated on data not sent to the R/T, BCC multiplexing by sharing the PGC among several R/Ts and reading/writing the partial BCC accumulation on a character by character basis, VRC generation/checking on characters appearing on a bidirectional data bus, and programmable character comparisons or searches.

PGC operation is half duplex (either receive or transmit, one way or two way alternate). Full duplex (two way simultaneous) is achieved by using two PGCs. The device is directly compatible with the Signetics SCN2651 Programmable Communications Interface (PCI) and SCN2661 Enhanced Programmable Communications interface (EPCI). When used in BISYNC modes with the SCN2661, software requirements are minimized by the SCN2653-SCN2661 control character comparisons, character sequence comparisons, and automatic DLE insertion/detection.

Other bus oriented R/Ts can be interfaced to the PGC with a minimum of external circuitry. See Figure 1 for a typical system configuration.

This NMOS LSI circuit is TTL compatible, operates from a single +5V supply and is contained in a 16 pin dual in line package.

### BLOCK DIAGRAM

The PGC consists of the following six major sections: the operation control, character class array, DLE ROM, character register, BCC and parity generators, and BCC registers. These sections communicate with each other via an internal data bus and an internal control bus. The internal data bus interfaces to the CPU data bus via a data bus buffer.

### Operation Control Unit

This functional block stores configuration and operation instructions from the CPU and generates appropriate signals to control the device operation. It also contains read and write circuits to permit communications between the CPU and the PGC registers via the data bus. The mode, command, and status registers are in this logic block.

### Character Register

Characters to be considered for BCC generation, parity generation and checking, or character comparisons are loaded into this register by either  $\overline{CE0}$  or  $\overline{CE1}$ . This register serves as an input to the BCC and VRC generator, where the accumulation and parity generation takes place. The character register also serves as the input for character class array and DLE comparisons.

Table 1. Glossary

TERM/ABBREVIATION	DEFINITION
BCC	Block check character
BTC	Block terminating character
SC	Search character
SSC	Second search character (preceded by DLE)
CRC-16	$X^{16} + X^{15} + X^2 + 1$ divisor, dividend pre-cleared
CRC-12	$X^{12} + X^{11} + X^3 + X^2 + X + 1$ divisor, dividend pre-cleared
LRC-8	Horizontal parity on least significant 7 bits; vertical parity on most significant bit
VRC	Vertical redundancy check (character parity)
R/T	Receiver/transmitter circuit. Also known as USART/USRT/UART/PCI/MPCC
BISYNC	IBM binary synchronous communications (BSC), ANSI X3.2B, ISO 1745
MSB	Most significant bit
LSB	Least significant bit
Rx	Receive
Tx	Transmit

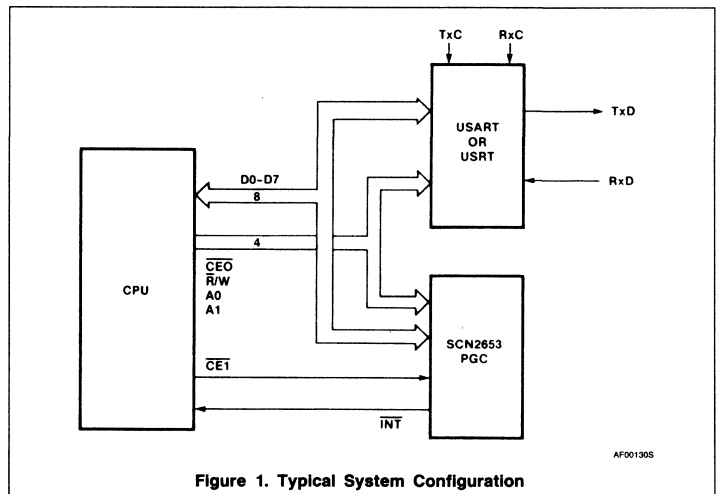

Figure 1. Typical System Configuration

### Character Class Array

This  $128 \times 2$  array holds the character class associated with each of 128 possible 7-bit characters. The array is zero after a master reset. When the character class array is loaded (see PGC Addressing), the character on the data bus is placed in the class specified by the contents of command register bits CR2 and CR3. The PGC uses these two command bits to represent four different character classes. These are:

1. Normal class (included in the accumulation)
2. SYN character/BISYNC not included class
3. Block terminating character/search class

4. Second search character class (preceded by DLE)

These encoded character classes are used by the PGC:

1. To control the BCC accumulation of associated characters in BISYNC modes only. BCC accumulation in automatic or single accumulation modes is carried out independent of the character classes.
2. To detect characters and two character sequences in all modes of accumulation and to set the control character detect bits in the status register.

It should be noted that any number of characters (up to 128 for CRC-16 or LRC-8; up to 64 for CRC-12) can be put into any one class.

## Polynomial Generator Checker (PGC)

SCN2653/SCN68653

2

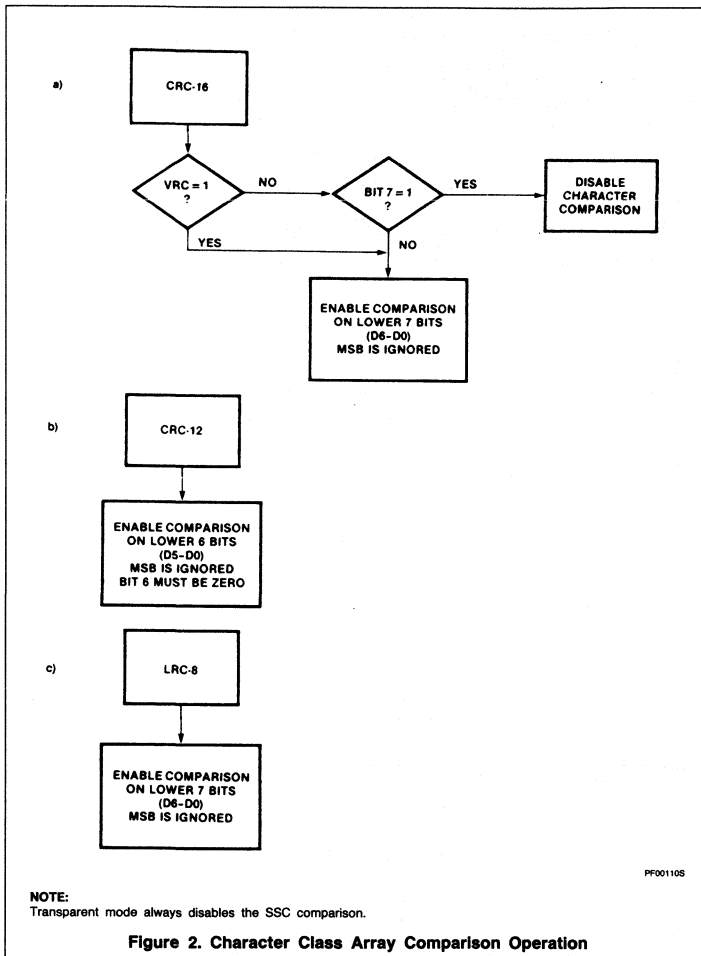

If VRC is specified along with CRC-16 then the least significant 7 bits of the character are used for character array comparison. If VRC is not enabled, but CRC-16 is, the MSB of the character then determines whether a character comparison is to take place. If the MSB is 0, the comparison takes place; if the MSB is 1, the comparison does not take place and the character is processed as though it were in the normal class. This enables the PGC to detect all communication control characters and DLE-SSC sequences.

Only the first 64 locations of the array are accessed if CRC-12 is selected. The user should right justify each six bit character (D0-

D5) to be written into the character class array. Bit 6 must be zero.

If VRC is enabled, the generated parity becomes the most significant bit of the character to be compared. VRC is not allowed in BISO SYNC transparent mode.

The method in which the character register contents is compared against the character class array depends on the BCC polynomial chosen. Figure 2 illustrates the comparison process.

#### DLE Read Only Memory

The DLE characters are stored internally and are selected by the error polynomial as follows:

CRC-12: 01 1111

LRC-8 or CRC-16:

No VRC or odd VRC: 0001 0000

Even VRC: 1001 0000

#### BCC and Parity Generator

This functional block performs all the necessary computation to generate and update the BCC accumulation on a character by character basis. It contains the three generator polynomials (CRC-16, CRC-12, and LRC-8) that can be selected to compute the BCC. This block also checks and generates odd or even parity for 7-bit (ASCII) characters.

#### BCC Registers

This block consists of two 8-bit registers (BCC upper and BCC lower) which contain the high and low order bytes of the BCC accumulation. The result of the accumulation from the BCC and parity generator is stored in these registers. A recirculating register address pointer is initialized by a power on, master reset, or clear BCC command. The pointer alternately selects BCC upper and lower on successive BCC register accesses for CRC-16 or CRC-12. For LRC-8, BCC upper is always selected.

BCC upper and lower are cleared by a clear BCC or master reset command. The highest term of the BCC polynomial is always represented by bit 0 of BCC upper; the lowest term is always represented by bit 7 of BCC lower (see Figure 3, Orientation of BCC Polynomials.)

The length of the block check character depends on the error checking polynomial that is selected. If LRC-8 is chosen, the BCC result is stored entirely in BCC upper. The BCC lower remains unchanged from previous setting. Both BCC registers are used when CRC-16 is specified. When CRC-12 is selected, the block check character is 12 bits long. The six least significant bits of the BCC are stored in the least significant bits of the BCC lower. The remaining upper six bits of the BCC are stored in least significant bits of BCC upper. The two most significant bits in each BCC register are filled with zero.

The BCC register(s) are read by the CPU after the last data character is transmitted. They can then be sent to the R/T to complete a transmitted block of data. These registers are read and loaded when one PGC is time-shared by several R/Ts. Refer to Applications Information—Multiplexed PGC.

#### PGC Addressing

All internal registers and the character class array are selected by the unique address codes shown in Table 2.

Polynomial Generator Checker (PGC)

SCN2653/SCN68653

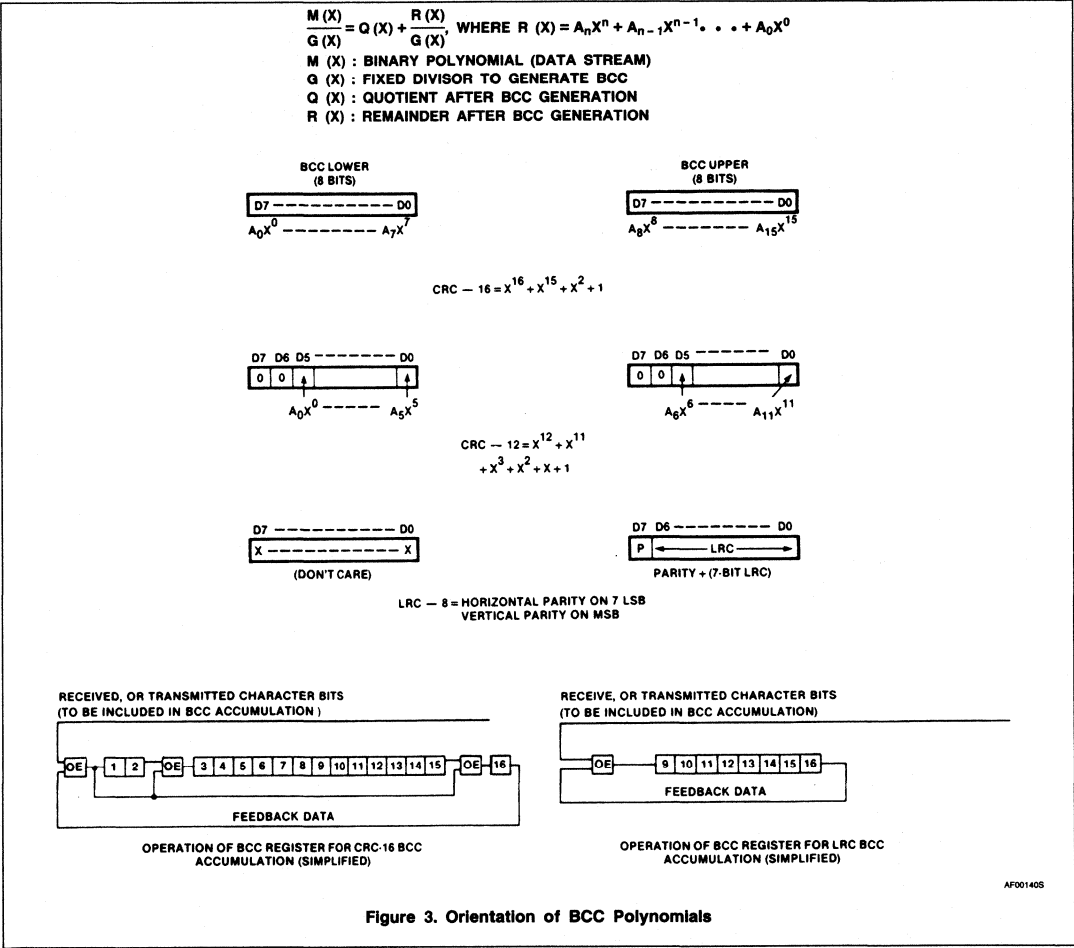

AF001405

## Polynomial Generator Checker (PGC)

SCN2653/SCN68653

Table 2. Address Codes

CE0	CE1	A1	A0	R/W	FUNCTION
0	0	X	X	X	Operation not guaranteed
0	1	0	0	0	If MR2 = 0 load data bus into character register
					If MR2 = 1 PGC not selected <sup>1</sup>
0	1	0	0	1	If MR2 = 1 load data bus into character register
					If MR2 = 0 PGC not selected <sup>1</sup>
0	1	0	1	X	PGC not selected <sup>1</sup>
0	1	1	0	X	PGC not selected <sup>1</sup>
0	1	1	1	X	PGC not selected <sup>1</sup>
1	0	0	0	0	Read character register
1	0	0	0	1	Load data bus into character register if MR1,0 ≠ 00 <sup>2</sup> ; write character class array using CR3, CR2 class code if MR 1,0 = 00 <sup>3, 4</sup>
1	0	0	1	0	Read Status register
1	0	0	1	1	Write command register
1	0	1	0	0	Read mode register
1	0	1	0	1	Write mode register
1	0	1	1	0	Read BCC upper/lower <sup>5</sup>
1	0	1	1	1	Write BCC upper/lower <sup>5</sup>
1	1	X	X	X	PGC not selected <sup>1</sup>

## NOTES:

1. Data bus is 3-State.
2. Character will not be accumulated unless MR3 = 1.
3. Character will not be accumulated even if MR3 = 1.
4. The mode bits MR1 and MR0 are cleared to 00 by power-on-reset, master reset, or by loading the mode register bits MR1 and MR0.
5. Recirculating internal pointer selects BCC upper on first access, BCC lower on next access for all BCCs except for LRC-8; in case of LRC-8, the pointer only selects BCC upper.

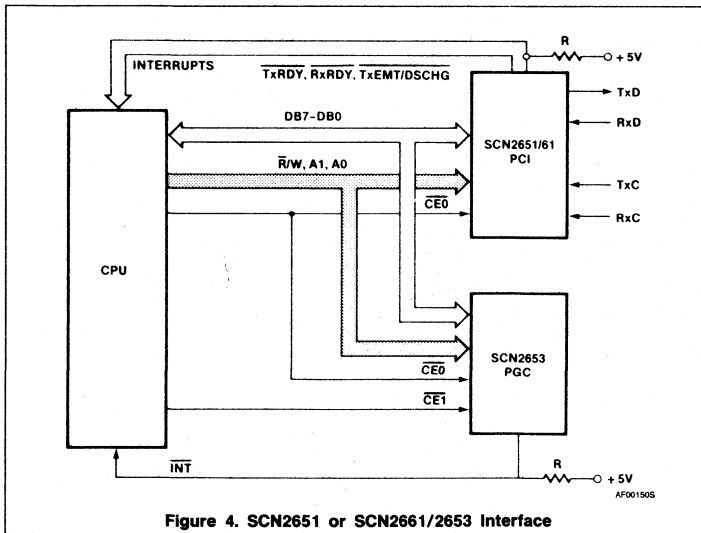

Figure 4. SCN2651 or SCN2661/2653 Interface

## INTERFACE SIGNALS AND TIMING

PGC data transfers are controlled by A1, A0, and R/W which must be stable prior to the active low going chip enable pulse. CE0 is used for PGC monitoring of data transfers between a CPU/DMA controller and a R/T; CE1 is used for direct CPU-to-PGC transfers. MR3 must be set prior to loading the character register in order to accumulate or compare characters via CE1. The active low (leading) edge of chip enable initiates a PGC read/write cycle; the rising (trailing) edge ends the cycle and also serves as a write strobe.

When loading the character, mode, or command register, the data bus is strobed into the selected register on the trailing (rising) edge of the appropriate CE. When writing into the character class array, the data on the bus (the special character) is placed in the class specified by command register bits CR3 and CR2.

Characters are transferred into the character register when CE0 is active (low) depending on the state of MR2 and the R/W input. Characters (from the R/T) are loaded into the character register when in receive mode (MR2 = 0 and R/W = 0) while CPU/DMA characters are loaded into the character register when in transmit mode (MR2 = 1 and R/W = 1). The time between consecutive chip enables is given by  $t_{CEC}$  or  $t_{CED}$ .

The open drain active low interrupt signal (INT) goes active whenever one or more of four maskable status conditions (SR0-SR3) are true (= 1). A status read deactivates INT.

The same techniques used in interfacing the SCN2651 PCI to 8-bit microprocessors can be used to interface the SCN2653 PGC (consult Application Note M22). Note that when addressing the R/T's holding registers, the PGC pins must have A1, A0 = 00 and that the address and R/W signals must be stable (set up) prior to the active low chip enable. When using the SCN2651 or SCN2661 as the R/T, the PGC's A1, A0, R/W, and CE0 are directly connected to comparable SCN2651 or SCN2661 signals. Schematics of an SCN2653 monitoring data transfers to/from the Signetics SCN2651/2661 and SCN2652 are shown in Figures 4 and 5.

An alternate interfacing technique is to treat the PGC as an independent peripheral device. This necessitates a write character register instruction after the CPU reads or writes a character to or from the R/T.

# Polynomial Generator Checker (PGC)

# SCN2653/SCN68653

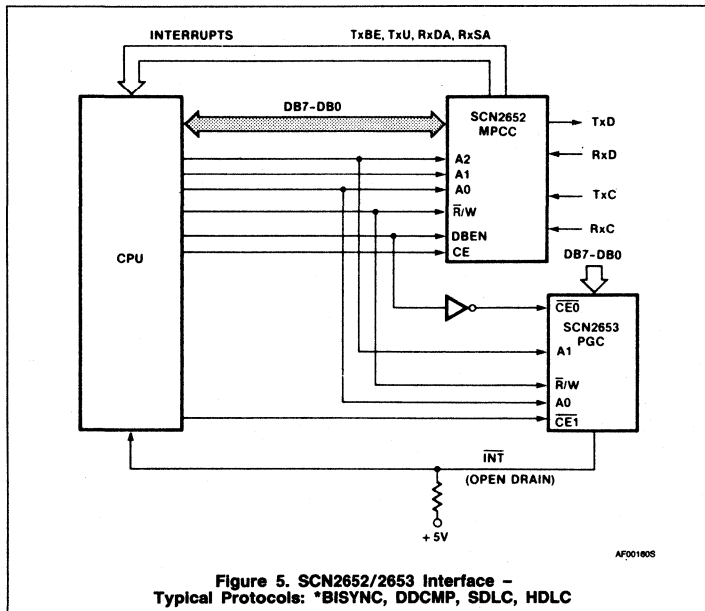

Figure 5. SCN2652/2653 Interface - Typical Protocols: \*BISYNC, DDCMP, SDLC, HDLC

### PGC PROGRAMMING

The PGC operational mode must be initially programmed by the CPU (see Figure 6). The mode register, command register and character class array should be written into, after a power-on-reset or a master reset command. The character class array should be programmed only for the classes pertinent to the application. After a master reset, the character class array is zero which places all characters in the normal class (included in the BCC accumulation).

### OPERATION

The PGC should be initially configured by the CPU (via CE1) prior to systems operation. This is done by loading the mode register,

command register and character class array (see PGC PROGRAMMING). Characters may then be loaded into the character register for BCC accumulation, VRC generation/checking, BTC/SC and DLE-SSC comparisons. See Table 3 for a summary of BCC accumulation modes.

BCC accumulation depends on the mode selected.

### BISYNC Normal

In BISYNC normal mode, all characters loaded into the character register are accumulated except those in the SYN/BISYNC not included class. During receive (MR2 = 0), a BTC/SC match will cause the BCC accumulation to stop after the next one (LRC-8) or two (CRC-12 or CRC-16) characters have been accumulated. At that time, if the BCC accu-

mulation does not equal zero, the BCC error bit (SR0) will be set and INT will go active if the corresponding mask bit (CR4) is enabled (= 1). In transmit (MR2 = 1), the BCC accumulation is automatically stopped once the BTC/SC character has been accumulated. The CPU must read the BCC upper and BCC lower (CRC-12 or CRC-16) register(s) and transmit them to the R/T.

Note that the received BCCs are not subject to VRC if CRC-16 is selected. If LRC-8 is selected, the received BCC is subject to VRC. An incorrect result will set the VRC error bit (SR1). After its accumulation, the least significant 7 bits of BCC upper are checked and a non-zero result will set the BCC error bit (SR0). BCCs are not checked against the character class array nor are they compared to the DLE ROM.

Second search character (SSC) detection is enabled so that a DLE-STX or two character communication control sequence can be detected.

### BISYNC Transparent

BISYNC transparent mode should be used for data blocks beginning with DLE-STX if the DLEs are transferred between CPU and R/T (CE0) or CPU and PGC (CE1), i.e., DLEs are not stripped. VRC should be disabled in this mode. Characters excluded from the BCC accumulation are the first DLE of a DLE-non SYN sequence pair and the DLE-SYN sequence if not preceded by an odd number of DLEs. For example, consider the following transparent mode character string:

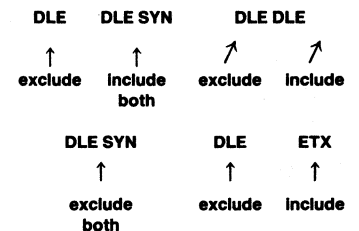

## Polynomial Generator Checker (PGC)

SCN2653/SCN68653

Table 3. Summary of BCC Accumulation Modes

ACCUMULATION MODES	START ACCUMULATION	STOP ACCUMULATION	CHARACTERS EXCLUDED FROM ACCUMULATION
BISYNC normal and BISYNC transparent	Clear BCC registers command Mode register is loaded with BISYNC or automatic mode Start accumulation command Load BCC registers	After BTC has been detected and received BCC is accumulated After transmitted BTC has been accumulated Single mode is selected	SYN/BISYNC not included class in normal mode DLE-SYN/not included class and first DLE of a DLE non SYN pair in transparent mode. These characters are not excluded if preceded by an odd number of DLEs
Automatic	Same as above	Single mode selected	None
Single	Start accumulation command	After each character has been accumulated	Up to user who must generate start accumulation command for each character to be included

In receive and transmit modes, the termination of BCC accumulation works exactly as in BISYNC normal, except that the BTC/SC must be immediately preceded by an odd number of DLEs to be identified as a BTC/SC.

Second search character detection is not enabled in BISYNC transparent.

After a BTC/SC class character is detected by the PGC when receiving in either BISYNC mode, the following one or two characters are accumulated (depending on LRC-8 or CRC-12/16, respectively) and the PGC will automatically stop further accumulation. However, the PGC can continue the accumulation if a start accumulate command is issued or either BISYNC mode is loaded into the mode register. The start accumulate command should be given to the PGC before loading the character that follows the detected BTC/SC. This procedure enables a special search character to be detected (the BTC/SC detect bit (SR2) will be set and an interrupt generated if CR6 = 1) with the BCC accumulation continuing (see Figures 7 and 8).

#### Automatic Accumulate

All characters loaded into the character register are accumulated, BTC/SC and SSC detection is enabled. The BCC accumulation is not automatically terminated. (The CPU must use single accumulate mode to stop the accumulation). When in receive mode, the BCC error bit (SR0) is set/reset after accumulating each character so that the CPU must examine this bit after the last character is accumulated. SR0 = 0 if the accumulated remainder in the BCC register(s) is zero; otherwise SR0 = 1. Examples of use of automatic accumulate mode usage include an R/T (SCN2651/SCN2661) in transparent DLE/SYN strip mode and asynchronous/synchronous/parallel DDCMP.

#### Single Accumulate

All characters for which a start accumulate command (CR1, CR0 = 01) is given are accumulated and compared against the character class array. If not given, the BCC accumulation is not updated and BTC/SC and SCC detection is disabled. Operation in this mode is otherwise identical to automatic accumulate.

Single accumulate mode can be used to selectively accumulate characters under CPU control or to accumulate characters that were unintentionally excluded in one of the other modes.

#### Polynomial Selection and DLE Comparison

The BCC polynomial may be CRC-16, CRC-12 or LRC-8. The cyclic redundancy check (CRC) is generated by dividing the binary value of a character in the character register by the selected polynomial. The quotient is discarded and the remainder is used as the BCC (two 6-bit characters for CRC-12, two 8-bit characters for CRC-16). CRC-16 uses all 8 bits of each BCC register. CRC-12 uses the least significant 6 bits of the BCC registers. The two most significant bits of the BCC registers are cleared to zero whenever CRC-12 is selected (see Figure 3).

When the PGC is in receive mode (MR2 = 0), the received BCC will be accumulated. The result will be zero for an error free message.

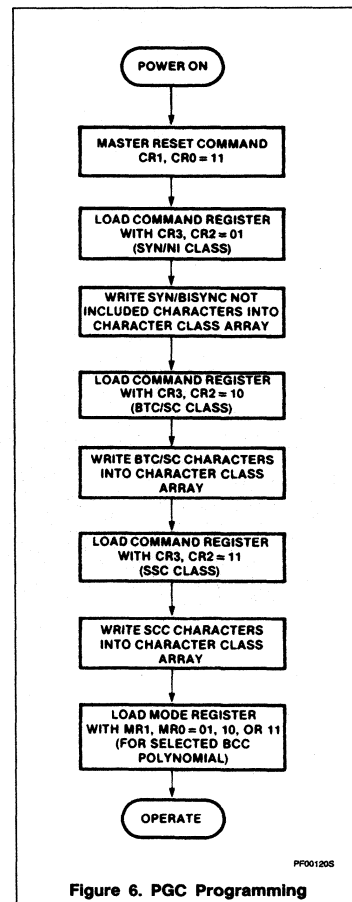
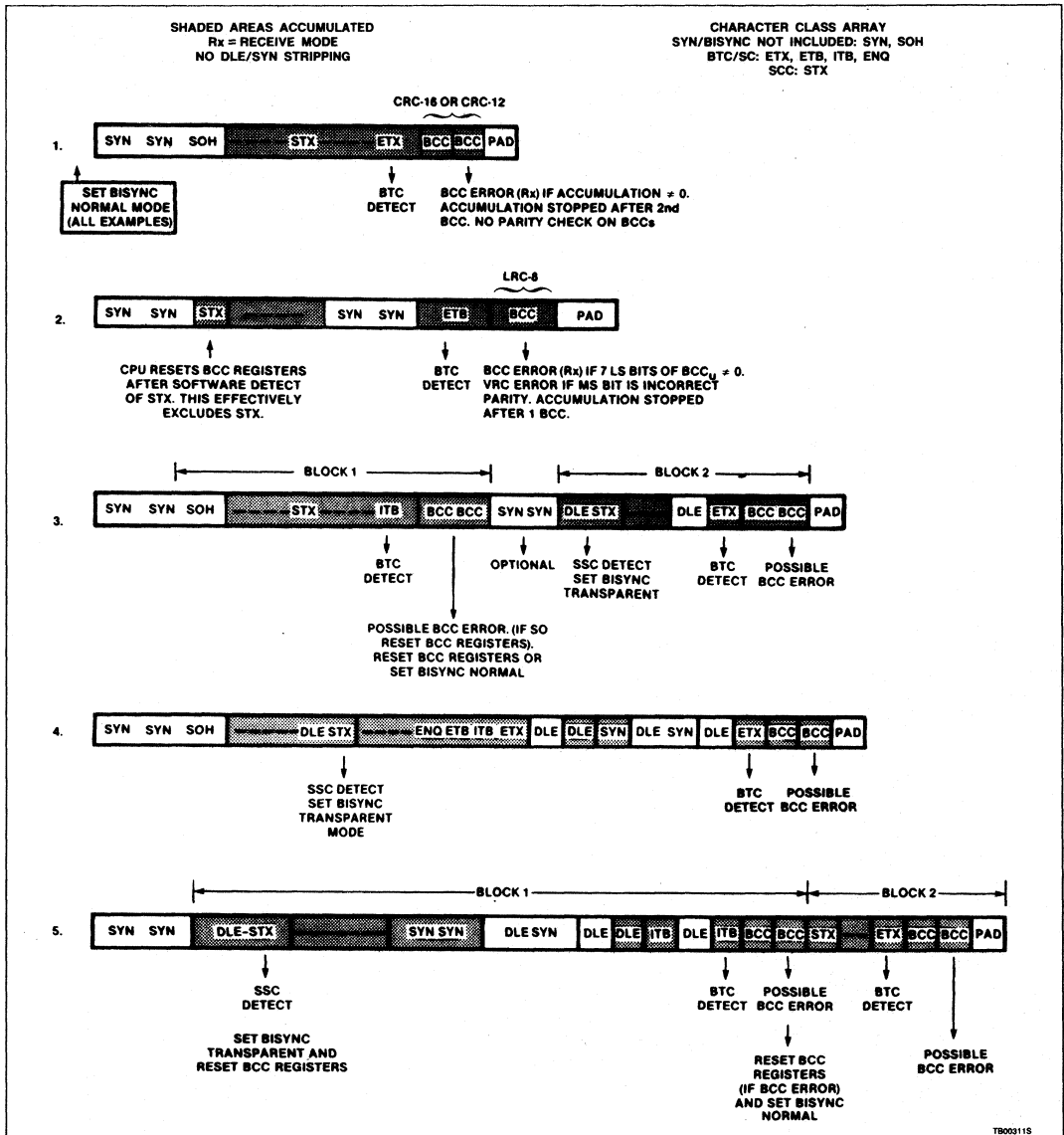

Figure 6. PGC Programming

# Polynomial Generator Checker (PGC)

# SCN2653/SCN68653



**NOTES:**

1. BCC error only for receive mode. In transmit mode, CPU must respond to BTC detect by reading the BCC register(s) and sending them to the R/T. The accumulation is stopped after the BTC is accumulated.
2. ENQ (DLE - ENQ) in a text message should be treated as an abort.
3. Opening SYN's may be stripped by the R/T.
4. The single accumulate mode and command can be used to accumulate a character that inadvertently was excluded. (For example, the DLE of a DLE - STX if the PGC was in transparent mode and there was not a line turnaround prior to the DLE). The single accumulation should be done using CET after the BCC(s) have been accumulated.

Figure 7. Examples - Bisync Text Message BCC Accumulation



## Polynomial Generator Checker (PGC)

SCN2653/SCN68653

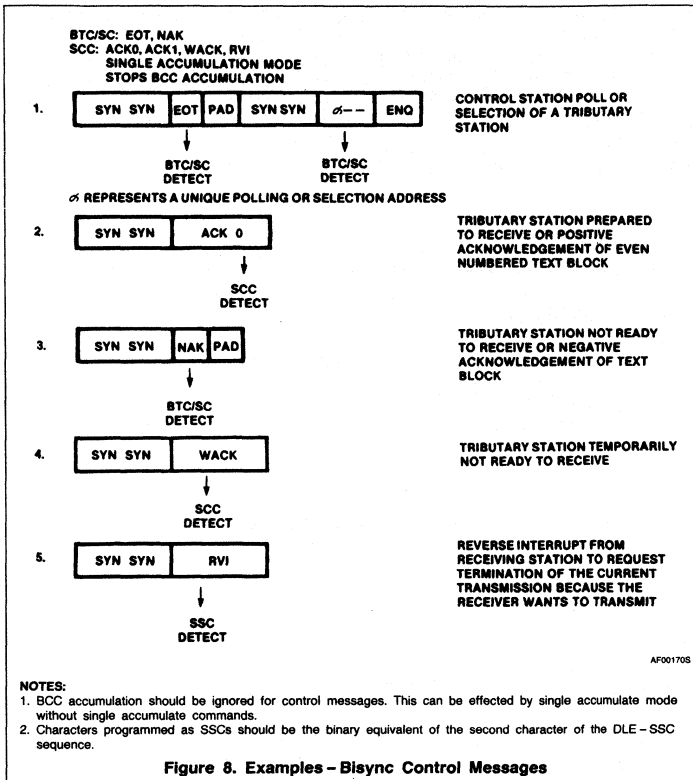

Figure 8. Examples - Bisync Control Messages

CRC-12 is used with 6-bit codes. The internal 6-bit transcode DLE character hex 1F is selected by CRC-12. VRC should be disabled (MR4 = 0) for CRC-12 operation. The two most significant bits of the character register are ignored when compared to the internal 6-bit DLE. When the character is checked against the character class array, the MSB is ignored and the next MSB (bit 6) is assumed to be zero. If CRC-12 is specified, the user must write to the character class array with bit 6 cleared.

CRC-16 or LRC-8 implies the use of ASCII or EBCDIC although any 7-bit plus parity or 8-bit no parity code may be used (with DLE = hex 10 or hex 90). The DLE character compare is on an 8-bit basis with the generated parity (if VRC is enabled) as the MSB. When the character is compared against the character class array, the MSB is not used. This may result in a false BTC or SSC detection if there is a VRC error. However, the VRC error bit (SR1) will be set under that condition.

The LRC-8 is generated by the exclusive OR of the 7 least significant bits of the character

register and the BCC upper. The most significant bit of the LRC-8 check character is a vertical odd/even parity bit (MR5 = 0/1), which is generated on the least significant bits of that character. The selection of LRC-8 implies VRC is enabled and that only the BCC upper is used for the BCC accumulation. The BCC lower remains unchanged from previous setting.

#### VRC Generation and Detection

Parity (VRC) is enabled by MR4 and specified as odd or even by MR5. VRC should be disabled when in BISYNC transparent mode and whenever CRC-12 or CRC-16 (EBCDIC) is selected as the BCC polynomial. MR4 = 1 enables VRC generation and detection for both receive and transmit operations. Characters loaded into the character register will have VRC generated on the least significant 7 bits with the generated parity bit written into the character register MSB. If the generated parity does not match the MSB of the loaded character, the VRC error bit (SR1) is set and  $\overline{INT}$  asserted if the corresponding mask bit was enabled (CR5 = 1). Thus, if 7-bit charac-

ters are to be transmitted with VRC, CR5 should be zero and SR1 ignored. 8-bit characters with a VRC bit in the MSB position are parity checked by the PGC in both transmit (to R/T) and receive (from R/T) modes, i.e., the PGC operates as a data bus parity checker.

## CHARACTER CLASSES

### Normal (Included in the Accumulation)

Any character that belongs to this class is normal data, i.e., the character is not a communication control or other special character. Characters in this class are always accumulated in BISYNC, automatic and single accumulation modes.

### SYN Character/BISYNC Not Included

SYN characters are never accumulated in BISYNC normal accumulation mode. In BISYNC transparent accumulation mode, the DLE-SYN character pair is not accumulated, but a SYN not preceded by a DLE is accumulated. (DLE is implied as an odd number of DLEs).

### Block Termination Character (BTC)/Search Character (SC)

BTC/SC characters have two functions in the PGC: termination of BCC accumulation and character detection. In BISYNC transparent mode, a BTC/SC must be preceded by an odd number of DLEs to be recognized.

#### Termination of BCC Accumulation

In BISYNC normal and transparent accumulation modes, the PGC will stop the accumulation upon the detection of the BTC/SC character. Examples of BTCs are ETX, ETB, ITB, ENQ.

In receive mode, the accumulation is stopped after the following one (LRC-8) or two (CRC-12, CRC-16) character(s) have been accumulated. In transmit mode, the accumulation is stopped after the BTC/SC character has been accumulated. The BTC/SC character is always accumulated in all of the accumulation modes.

#### Character Detection

BTC/SC characters will be detected in any of the four accumulation modes when that character is being accumulated. The BTC/SC status bit (SR2) is set on detection. Since detection also stops BISYNC BCC accumulation, the BISYNC accumulation must be restarted if the character is not a BTC. This can be effected by loading BISYNC mode into the mode register or generating a start accumulation command.

# Polynomial Generator Checker (PGC)

# SCN2653/SCN68653

## Second Search Character Class (SSC)

Control functions in character oriented data link control procedures can be represented by a sequence of two characters, the first character being a DLE. Examples include ACK0, ACK1, WACK, RVI, DISC, WBT and the initiation of transparent text (DLE-STX).

The PGC will detect such sequences, except in BISYNC transparent mode, when an SSC class character is being accumulated after being immediately preceded by an odd number of DLEs. Under those conditions, the SSC status bit (SR3) will be set.

The SSC character is always accumulated in all of the accumulation modes.

## REGISTER BIT DESCRIPTION

The operation of the PGC is determined by programming the mode register and the command register. The status register provides feedback on potential interrupt conditions. Formats of these registers are shown in Table 4.

Table 4. PGC Register Bit Formats

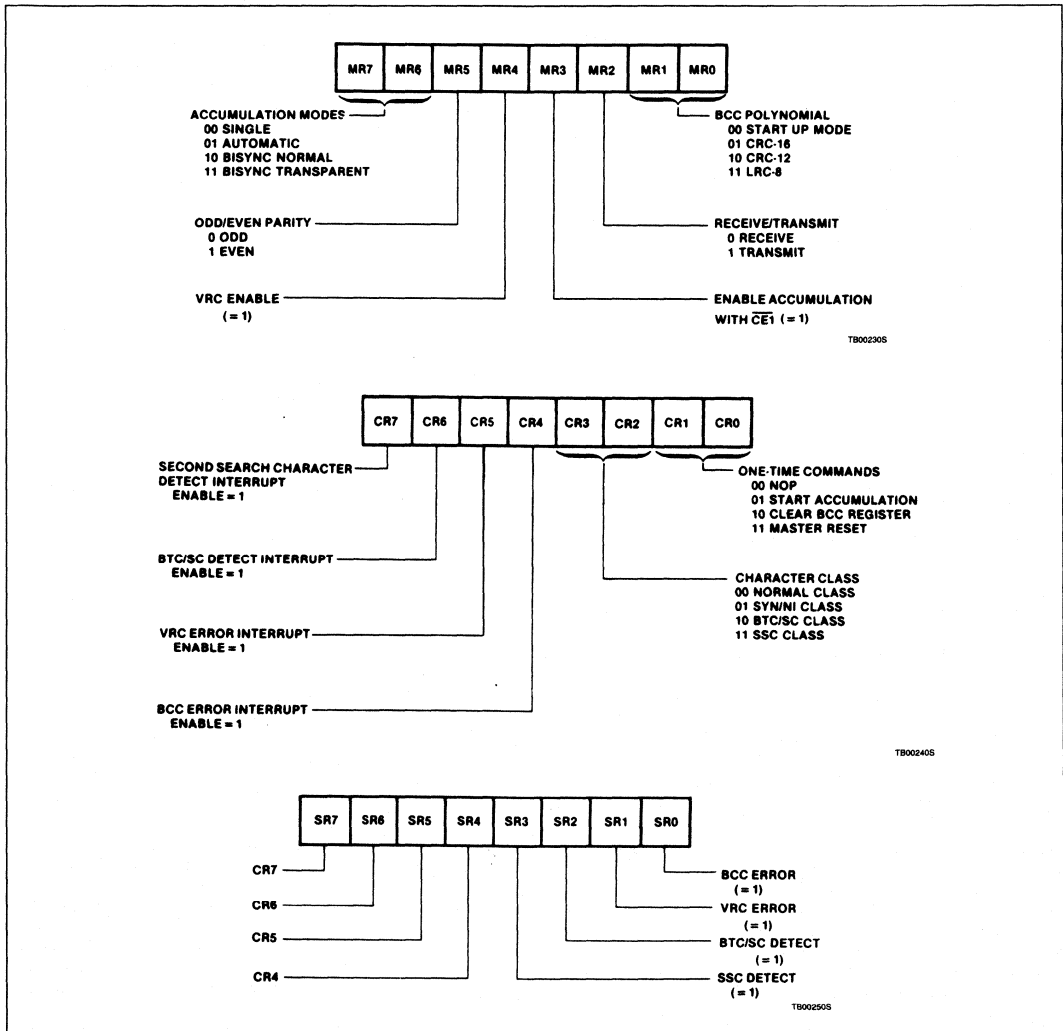

# Polynomial Generator Checker (PGC)

SCN2653/SCN68653

2

**Table 5. BCC Accumulation by Character Class**

CR3	CR2	CLASS	BISYNC NORMAL	BISYNC TRANSPARENT	AUTOMATIC ACCUM	SINGLE ACCUM
0	0	Normal SYN/BISYNC not included	Yes	Yes	Yes	Yes
0	1		No	Yes, unless preceded by an odd number of DLEs	Yes	Yes
1	0	BTC/SC	Yes	Yes	Yes	Yes
1	1	SSC	Yes	Yes	Yes	Yes

**NOTE:**  
 †Preceded by DLE

### Mode Register

The mode register defines general PGC operation characteristics. MR1 and MRO = 00 permit the character class array to be programmed. These bits will be zero after a power on or master reset command. After the character class array is programmed, these bits should be set to 01,10, or 11 to select the CRC-16, CRC-12 or LRC-8 polynomials.

MR2(Tx/Rx) determines whether or not the PGC is to generate (Tx) or generate and check (Rx) the BCC. It is used with R/W to determine if the data bus is to be loaded into the character register when CE0, CE1, A1, A0 = 0100.

If MR2 = 1: 1) the PGC will generate the BCC but will never set the BCC error bit (SR0). 2) If the R/W pin is high when CE0, CE1, A1, A0 = 0100, then the data bus will be loaded into the character register. If R/W is low under these conditions, the PGC is not selected.

If MR2 = 0: 1) the PGC will accumulate the BCC and set the BCC error bit (SR0) when appropriate. 2) If the R/W pin is low when CE0, CE1, A1, A0 = 0100, then the data bus will be loaded into the character register. If R/W is high under these conditions, the PGC is not selected.

MR3 is a CE1 accumulate/compare enable bit. If MR3 = 0, characters loaded into the character register by CE1 are not accumulated, checked against the character class array, or compared to the DLE ROM. Parity will be generated and checked if VRC is enabled (MR4 = 1). The primary use of MR3 = 0 is to generate parity on a 7-bit character which is to be transmitted to an R/T. The CPU loads the character register with the 7-bit character and reads the 8-bit VRC generated character via CE1. This 8-bit character is then transferred to the R/T via CE0. Another application of MR3 = 0 is for a CPU to interleave parity checking on memory data (CE1) with on line R/T data transfer (CE0).

If MR3 = 1, characters loaded into the character register by CE1 will be accumulated (according to the BCC accumulation mode selected) and compared against the character class array and DLE ROM. This bit setting should be used when the CPU/DMA control-

**Table 6. BTC/SC and SSC Detection Conditions**

CLASS	BISYNC NORMAL	BISYNC TRANSPARENT	AUTO ACCUM	SINGLE ACCUM
BTC/SC	Yes	Yes	Yes	Yes †
SSC	Yes	No	Yes	Yes †

**NOTES:**  
 \* Only if immediately preceded by an odd number of DLEs.  
 † Start accumulate command necessary for detection.

ler sends data characters to be accumulated or compared to the PGC and the R/T is inactive (off line). If the R/T were active, then a DLE or BTC loaded into the character register via CE0 would cause incorrect accumulation and character comparisons if the next character was loaded via CE1.

MR4 is a VRC enable bit. If MR4 = 1, VRC is enabled as odd/even by MR5. VRC is generated on the 7 LS bits of the character and the MS bit is checked against the generated parity. If not equal, SR1 is set. If MR4 = 0, VRC is not enabled. MR4 = 0 is used for BISYNC transparent mode with ASCII code, and for both BISYNC modes for EBCDIC and SBT.

MR5 is an odd/even VRC bit. If MR5 = 1, the total number of 1 bits in the character including the parity bit is even. If MR5 = 0, the total number of bits is odd. This bit is ignored if MR4 = 0.

MR7, MR6 select the BCC accumulation mode. These modes have been previously discussed in the operation section.

### Command Register

The command register contains four interrupt enables, a 2-bit character class code used when programming the character class array, and 2 bits that specify three one time commands and a NOP.

CR1, CR0 = 00 is a NOP. This bit setting is used when changing CR7-CR2 without affecting any of the 3 one time commands.

CR1, CR0 = 01 is a start BCC accumulation command. In single accumulation mode, the character accumulated is the character that is in the character register at the time the command is given. The accumulation stops immediately after the character has been accumulated. If the command is given in

either of the BISYNC or automatic accumulation modes, it enables the PGC to accumulate the BCC starting with the next character loaded into the character register. This is a means of restarting a BISYNC normal accumulation after detection of a BTC/SC that is not a valid BTC (example; CR, LF, TAB). In all accumulation modes, a previously detected DLE will not be cancelled by this command.

CR1, CR0 = 10 is a clear BCC registers command. Both BCC registers are cleared along with the associated internal pointer and SR0-SR3. The pointer points to BCC upper. INT is forced high. This command permits BCC accumulation, starting with the next character loaded into the character register in BISYNC or auto modes. Single accumulate mode requires a start BCC accumulation command.

CR1, CR0 = 11 is a master reset command. All internal registers (except the character register), the internal pointer, and the entire character class array are cleared. INT is forced high.

CR3 and CR2 are used for programming the character class array. During a write character class array instruction, the character corresponding to the 7 LS bits of the data bus is placed in the class contained in CR3 and CR2. The encoded character classes control the accumulation of the associated character as shown in Table 5.

Detection operates under the conditions shown in Table 6.

CR7, CR6, CR5, CR4 are interrupt enables that individually enable/disable INT when the corresponding status register condition is true (set). Each bit is set in order to enable INT upon the condition. Each bit is reset to disable INT upon the condition. The state of

# Polynomial Generator Checker (PGC)

# SCN2653/SCN68653

these bits may be read via the status register (SR7, SR6, SR5, SR4).

The corresponding status bits (SR3, SR2, SR1, SR0) are set independent of the interrupt enables. The bit assignments are:

CR4—BCC error interrupt enable

CR5—VRC error interrupt enable

CR6—BTC/SC detect interrupt enable

CR7—DLE-SSC detect interrupt enable

## Status Register

This register reflects the status of the 4 conditions that are potential interrupt ( $\overline{INT}$ ) sources and the 4 interrupt enables in the command register. A status register read clears SR0, SR1, SR2, SR3 and deactivates  $\overline{INT}$ . These bits are also cleared by a master reset or clear BCC command.

SR0 is a BCC error bit. This bit can only be set in receive mode ( $MR2 = 0$ ). In BISYNC normal and BISYNC transparent modes, SR0 will be set/reset once the accumulation has been stopped by the detection of the BTC/SC character and accumulation of the BCC(s).

In automatic and single accumulate modes, SR0 is set/reset after each character in the character register has been accumulated.

The rules for the detection of a BCC error are:

SR0 = 1 LRC-8: 7 least significant bits of BCC upper  $\neq 0$   
 CRC-12, CRC-16: BCC upper or BCC lower  $\neq 0$

SR0 = 0 LRC-8: 7 least significant bits of BCC upper = 0  
 CRC-12, CRC-16: BCC upper and BCC lower = 0

SR1 is a VRC error bit. When set, this bit reports a character parity error (on receive or transmit) when parity is enabled ( $MR4 = 1$ ). Parity is odd/even as specified by MR5. The parity bit will be regenerated in the character register.

SR2 is a BTC/SC detect bit. When set, this bit indicates the character being accumulated is of the BTC/SC class for BISYNC normal, automatic and single accumulate modes. In

BISYNC transparent mode, the BTC/SC character being accumulated must be immediately preceded by an odd number of DLEs for this bit to be set.

SR3 is a DLE-SSC detect bit. This bit can only be set when in BISYNC normal, auto, or single accumulated modes. When set, it indicates that the character being accumulated is of the SSC class when that character was immediately preceded by an odd number of DLEs.

SR7, SR6, SR5, SR4 are interrupt enables. These 4 bits reflect the state of the interrupt enable command bits CR7, CR6, CR5, and CR4, as follows:

SR4—BCC error

SR5—VRC error

SR6—BTC/SC detect

SR7—SSC detect

## APPLICATIONS INFORMATION

### Dedicated PGC

The most efficient use of the 2653 is to dedicate one to each R/T for two way alternate (half duplex) operation or two to each R/T for two way simultaneous (full duplex) operation (see Figure 9). The CPU configures each PGC (using  $\overline{CE1}$ ) by initializing the mode register, command register, and character class array. Data transfers to or from the R/T can then be on a DMA basis with each receiver holding register ready signal used as a read request (RREQ) and each transmit holding register available signal used as a write request (WREQ) to the DMA controller. The CPU needs only to respond to enable interrupts from each of the PGCs. The individual  $\overline{INT}$  outputs can be wire-OR'd into single CPU interrupt ( $\overline{INTRPT}$ ) with one pull up resistor. Each PGC in this system has a unique address that is decoded into the respective chip enables.

The CPU or DMA controller could send a block of memory data to the PGC to be error checked without sending that data to the R/T. In that case,  $\overline{CE1}$  is used.

### Multiplexed PGC

One PGC may be time-shared among a few R/Ts if the CPU saves and restores the mode register and partial BCC result in the BCC registers. These registers are accessed via  $\overline{CE1}$ . There must be a separate save area for each R/T (serial channel) and a channel pointer indicating the last R/T that transferred or received a data character (see Figure 10).

The loading of the BCC registers will clear SR0-SR3 and all previously detected special characters, i.e., DLE, BTC/SC, BCC (BISYNC modes). The BCC accumulation will start again when the next character is loaded into the character register in all accumulation modes except single. That mode requires a start accumulation command.

Figures 11 and 12 represent software flow diagrams for transmit and receive service requests. Note that interrupts from all other R/Ts must be masked during a read or write to the BCC registers so as not to affect the internal BCC address pointer. It is recommended that all R/T interrupts be masked while servicing an interrupt that accesses any PGC register.

### BISYNC Operation

Table 7 is a concise listing of SCN2651/SCN2661 operating modes with recommended corresponding SCN2653 BCC accumulation modes.

### Character Comparator

The PGC can be used as a programmable data bus character comparator which monitors data bus transfers (CPU  $\leftrightarrow$  peripheral, CPU  $\leftrightarrow$  CPU, CPU  $\leftrightarrow$  memory, memory  $\leftrightarrow$  peripheral (via DMA)). The user selectively loads the character class array with BTC/SC and SSC characters to be compared. Status bits will be set and an interrupt can be generated upon SC and DLE-SSC detection. A match on one to 128 different characters or DLE-SSC sequences can be programmed.

Figure 13 depicts an arrangement where the DMA controller or slave CPU handles data bus transfers, the PGC interrogates the data bus, and the host CPU responds to PGC interrupts.

# Polynomial Generator Checker (PGC)

# SCN2653/SCN68653

2

**Table 7. BISYNC (ANSI 3.28, ISO 1745) Modes for SCN2651/SCN2661 and SCN2653**

SCN2651/SCN2661 OPERATING MODES	SCN2653 BCC ACCUMULATION MODE
Sync normal non-strip	BISYNC normal
Sync transparent non-strip	BISYNC transparent
Normal SYN/DLE strip <sup>1</sup>	BISYNC normal
Transparent SYN/DLE strip <sup>1</sup>	Automatic accumulate <sup>2</sup>
Async (with SYN/DLE characters)	BISYNC normal

**NOTES:**

1. CPU should switch to non-strip mode after BTC detect. Otherwise a received BCC could be inadvertently stripped.
2. SSC detect should be ignored.

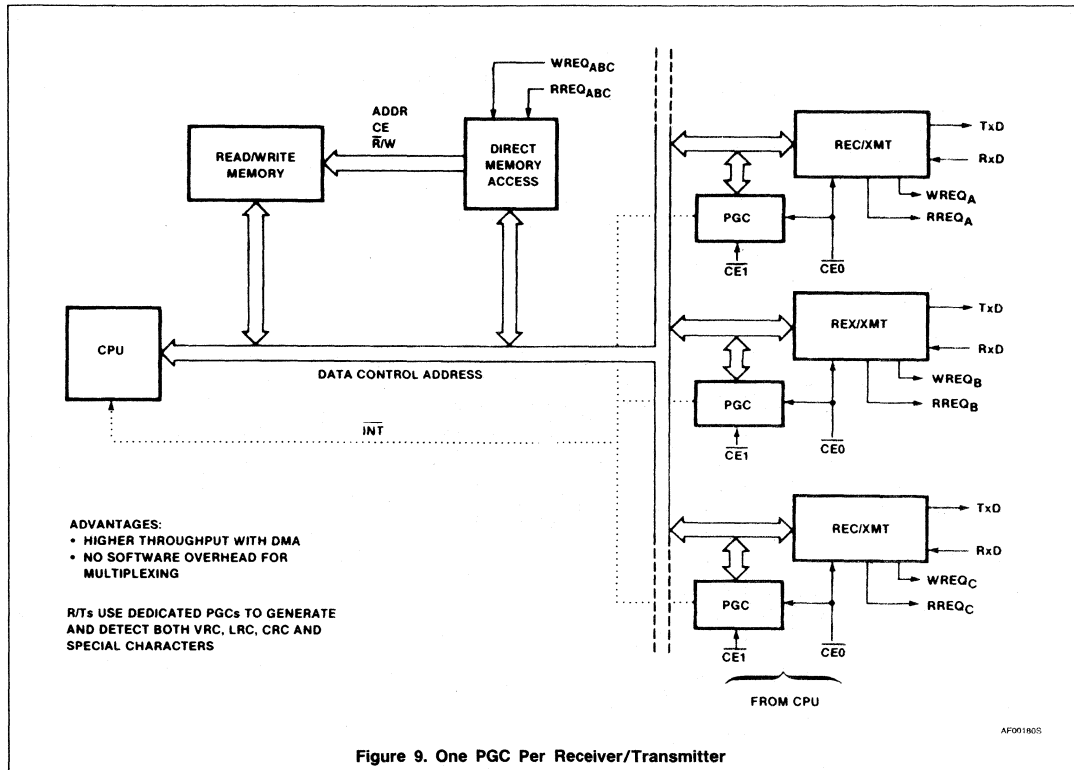

**Figure 9. One PGC Per Receiver/Transmitter**

Polynomial Generator Checker (PGC)

SCN2653/SCN68653

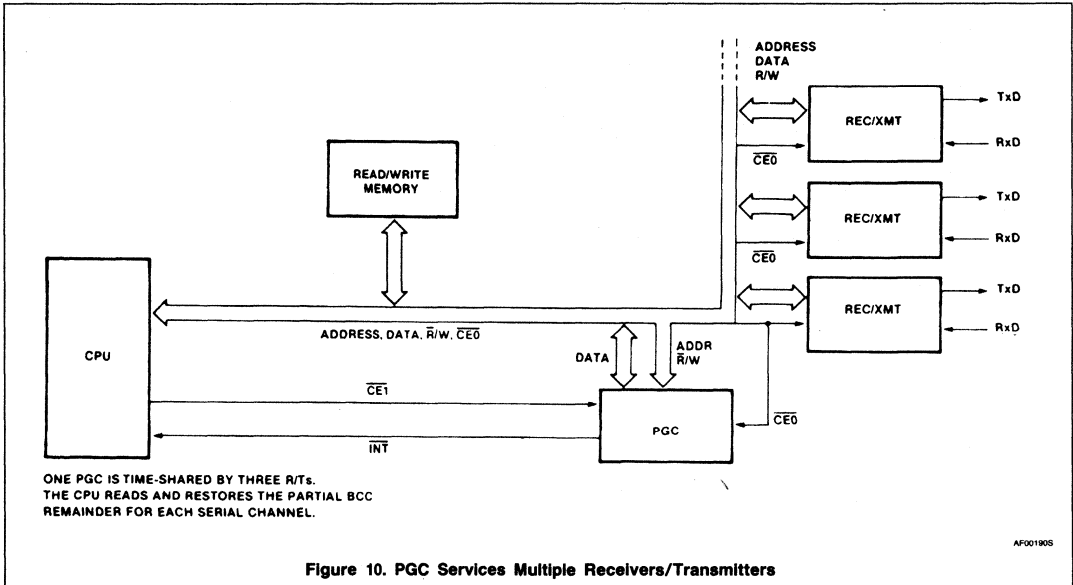

Figure 10. PGC Services Multiple Receivers/Transmitters

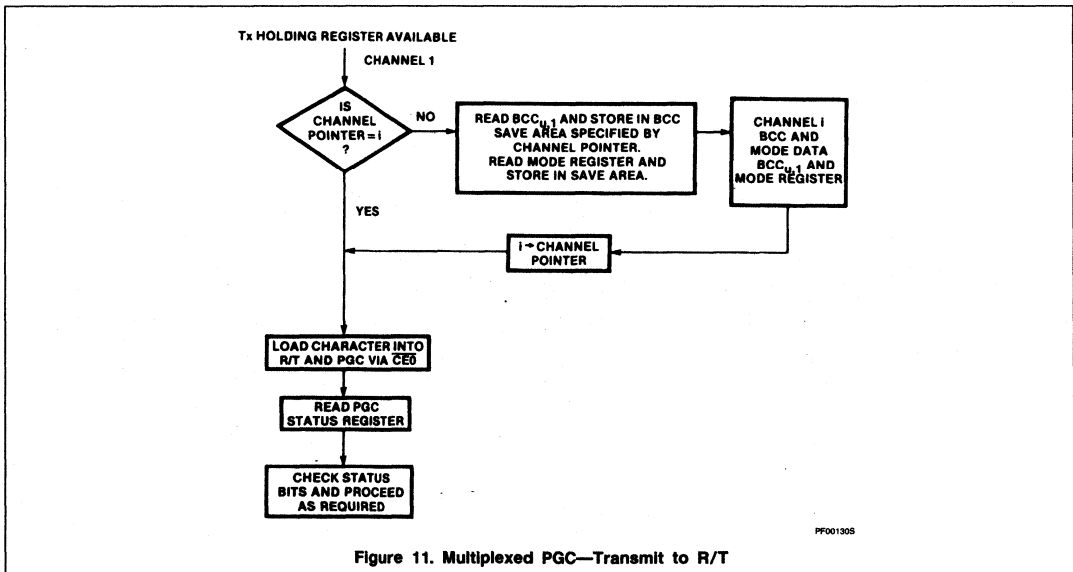
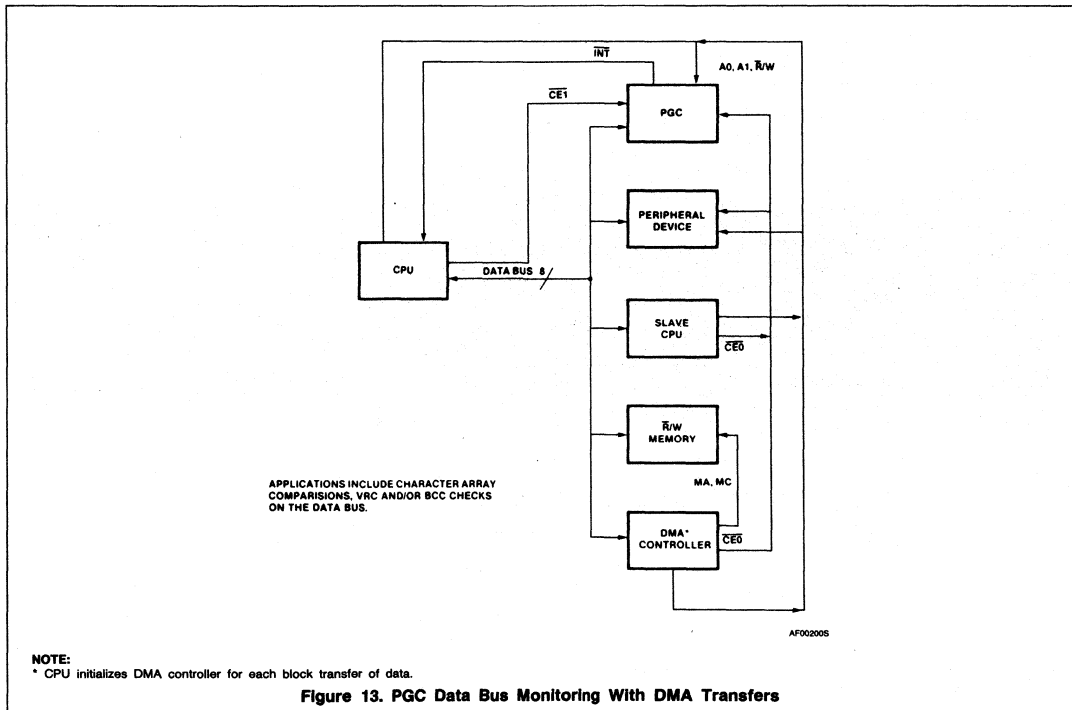
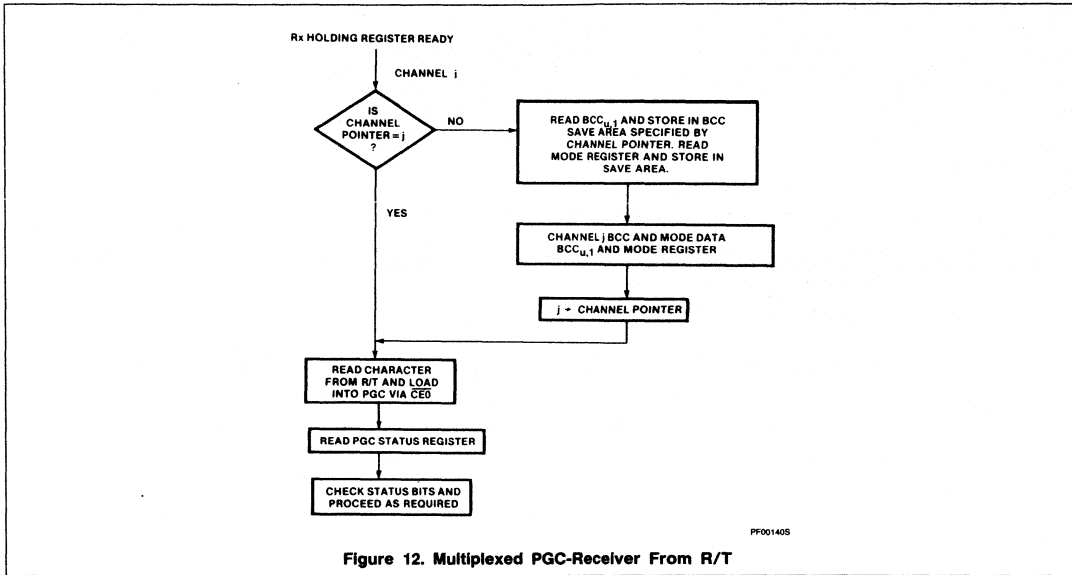

Figure 11. Multiplexed PGC—Transmit to R/T

Polynomial Generator Checker (PGC)

SCN2653/SCN68653



## Polynomial Generator Checker (PGC)

SCN2653/SCN68653

ABSOLUTE MAXIMUM RATINGS<sup>1</sup>

SYMBOL	PARAMETER	RATING	UNIT
T <sub>A</sub>	Operating ambient temperature <sup>2</sup> range	0 to +70	°C
T <sub>STG</sub>	Storage temperature range	-65 to +150	°C
	All voltages with respect to ground <sup>3</sup>	-0.5 to +6.0	V

## NOTES:

- Stresses above those listed under Absolute Maximum Ratings may cause permanent damage to the device. This is a stress rating only and functional operation of the device at these or any other condition above those indicated in the operation sections of this specification is not implied.
- For operating at elevated temperatures the device must be derated based on +150°C maximum junction temperature.
- This product includes circuitry specifically designed for the protection of its internal devices from damaging effects of excessive static charge. However, it is suggested that conventional precautions be taken to avoid applying any voltages larger than the rated maxima.

DC ELECTRICAL CHARACTERISTICS T<sub>A</sub> = 0°C to 70°C, V<sub>CC</sub> = 5V ± 5%

SYMBOL	PARAMETER	TEST CONDITIONS	LIMITS			UNIT
			Min	Typ	Max	
<b>Input voltage</b>						
V <sub>IL</sub> V <sub>IH</sub>	Low High		2		0.8	V
<b>Output voltage</b>						
V <sub>OL</sub> V <sub>OH</sub>	Low High	I <sub>OL</sub> = 2.2mA I <sub>OH</sub> = -400μA	2.4	0.25 2.8	0.45	V
I <sub>IL</sub>	Input load current	V <sub>IN</sub> = 0 to 5.5V			10	μA
<b>Output leakage current</b>						
I <sub>LD</sub> I <sub>LO</sub>	Data bus Open drain	V <sub>OUT</sub> = 4.0V V <sub>OUT</sub> = 4.0V			10 10	μA
I <sub>CC</sub>	Power supply current			45	75	mA

AC ELECTRICAL CHARACTERISTICS T<sub>A</sub> = 0°C to 70°C, V<sub>CC</sub> = 5.0V ± 5%<sup>1, 2, 3</sup>

SYMBOL	PARAMETER	LIMITS		UNIT
		Min	Max	
t <sub>CE</sub>	Chip enable pulse width	250		ns
t <sub>CED</sub>	Chip enable period D	1750		ns
t <sub>CEC</sub> <sup>4</sup>	Chip enable period C	1750		ns
t <sub>AS</sub>	Address setup	10		ns
t <sub>AH</sub>	Address hold	10		ns
t <sub>CS</sub>	Control setup	10		ns
t <sub>CH</sub>	Control hold	10		ns
t <sub>DS</sub> <sup>5</sup>	Data setup	150		ns
t <sub>DH</sub>	Data hold	15		ns
t <sub>DD</sub> <sup>6</sup>	Data delay time for read		200	ns
t <sub>DF</sub> <sup>6</sup>	Data bus floating time for read		100	ns
t <sub>INTL</sub> <sup>7</sup>	Interrupt low delay		1600	ns
t <sub>INTH</sub> <sup>7</sup>	Interrupt high delay		600	ns

## NOTES:

- Parameters are valid over operating temperature range unless otherwise specified.
- All voltage measurements are referenced to ground. All time measurements are at 50% level for inputs and at the 0.8V or 2V level for outputs. Input levels for testing are 0.45V and 2.4V.
- Typical values are at +25°C, typical supply voltages and typical processing parameters.
- t<sub>CEC</sub> = 600ns during PGC initialization when no BCC accumulation is in progress.
- t<sub>DS</sub> = 50ns whenever  $\overline{CE0}$  is used.
- Test conditions: C<sub>L</sub> = 150pF.
- INT is an open drain output.



Polynomial Generator Checker (PGC)

SCN2653/SCN68653

2

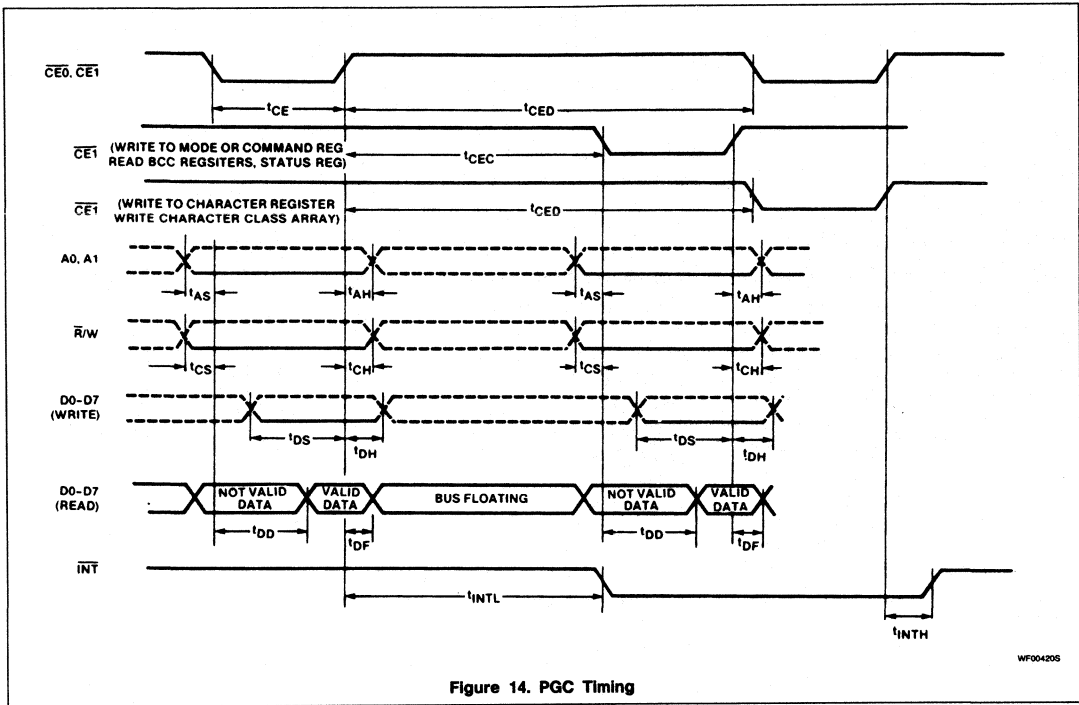

# SCN2661/SCN68661

## Enhanced Programmable Communications Interface (EPCI)

### Microprocessor Products

### Product Specification

#### DESCRIPTION

The Signetics SCN2661 EPCI is a universal synchronous/asynchronous data communications controller chip that is an enhanced version of the SCN2651. It interfaces easily to all 8-bit and 16-bit microprocessors and may be used in a polled or interrupt driven system environment. The SCN2661 accepts programmed instructions from the microprocessor while supporting many serial data communications disciplines — synchronous and asynchronous — in the full- or half-duplex mode. Special support for BISYNC is provided.

The EPCI serializes parallel data characters received from the microprocessor for transmission. Simultaneously, it can receive serial data and convert it into parallel data characters for input to the microcomputer.

The SCN2661 contains a baud rate generator which can be programmed to either accept an external clock or to generate internal transmit or receive clocks. Sixteen different baud rates can be selected under program control when operating in the internal clock mode. Each version of the EPCI (A, B, C) has a different set of baud rates.

#### FEATURES

- **Synchronous operation**
  - 5- to 8-bit characters plus parity
  - Single or double SYN operation
  - Internal or external character synchronization
  - Transparent or non-transparent mode
  - Transparent mode DLE stuffing (Tx) and detection (Rx)
  - Automatic SYN or DLE-SYN insertion SYN, DLE and DLE-SYN stripping
  - Odd, even, or no parity
  - Local or remote maintenance loopback mode
  - Baud rate: DC to 1Mbps (1× clock)

- **Asynchronous operation**
  - 5- to 8-bit characters plus parity
  - 1, 1½ or 2 stop bits transmitted
  - Odd, even, or no parity
  - Parity, overrun and framing error detection
  - Line break detection and generation
  - False start bit detection
  - Automatic serial echo mode (echoplex)
  - Local or remote maintenance loopback mode
  - Baud rate: DC to 1Mbps (1× clock)  
DC to 62.5kbps (16× clock)  
DC to 15.625kbps (64× clock)

- Internal or external baud rate clock
- 3 baud rate sets
- 16 internal rates for each set
- Double-buffered transmitter and receiver
- Dynamic character length switching
- Full- or half-duplex operation
- TTL compatible inputs and outputs
- RxC and TxC pins are short-circuit protected
- Single +5V power supply
- No system clock required

#### APPLICATIONS

- Intelligent terminals
- Network processors
- Front-end processors
- Remote data concentrators
- Computer-to-computer links
- Serial peripherals
- BISYNC adaptors

#### PIN CONFIGURATIONS

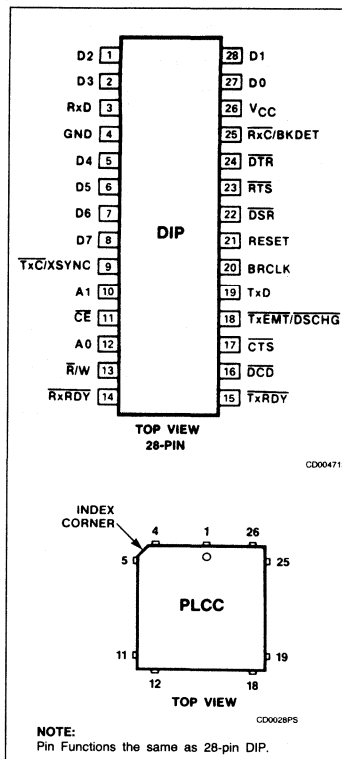

# Enhanced Programmable Communications Interface (EPCI)

## SCN2661/SCN68661

### ORDERING INFORMATION

PACKAGES	V <sub>CC</sub> = +5V ± 5%		
	Commercial	Automotive	Military
	0°C to +70°C	-40°C to +85°C	-55°C to +125°C
Ceramic DIP 28-Pin 0.6" Wide	SCN2661AC1I28 SCN2661BC1I28 SCN2661CC1I28	SCN2661AA1I28 SCN2661BA1I28 SCN2661CA1I28	SCN2661AM1I28 SCN2661BM1I28 SCN2661CM1I28
Plastic DIP 28-Pin 0.6" Wide	SCN2661AC1N28 SCN2661BC1N28 SCN2661CC1N28	Contact Factory	Not Available
Plastic LCC	SCN2661AC1A28 SCN2661BC1A28 SCN2661CC1A28	Contact Factory	Not Available

**NOTES:**

- See Table 1 for baud rates. Specify SCN2661A, B, or C depending on baud rate selected.
- The SCN68661 is identical to the SCN2661. Order using part numbers above.

### BLOCK DIAGRAM

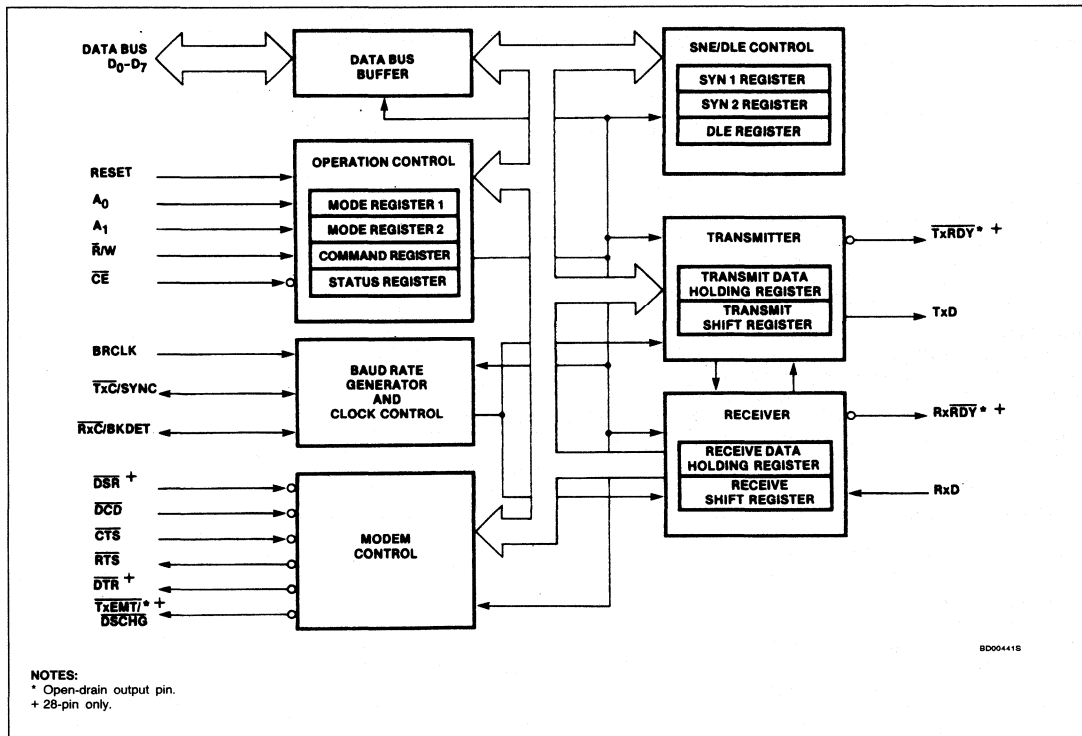

**NOTES:**

- \* Open-drain output pin.
- + 28-pin only.

BD004416

# Enhanced Programmable Communications Interface (EPCI)

SCN2661/SCN68661

## BLOCK DIAGRAM

The EPCI consists of six major sections: the transmitter; receiver; timing; operation control; modem control, and SYN/DLE control. These sections communicate with each other via an internal data bus and an internal control bus. The internal data bus interfaces to the microprocessor data bus via a data bus buffer.

### Operation Control

This functional block stores configuration and operation commands from the CPU and generates appropriate signals to various internal sections to control the overall device operation. It contains read and write circuits to permit communications with the microprocessor via the data bus and contains mode registers 1 and 2, the command register, and the status register. Details of register addressing and protocol are presented in the EPCI programming section of this data sheet.

### Timing

The EPCI contains a baud rate generator (BRG) which is programmable to accept external transmit or receive clocks or to divide an external clock to perform data communications. The unit can generate 16 commonly used baud rates, any one of which can be selected for full-duplex operation (See Table 1).

### Receiver

The receiver accepts serial data on the RxD pin, converts this serial input to parallel format, checks for bits or characters that are unique to the communication technique and sends an "assembled" character to the CPU.

### Transmitter

The transmitter accepts parallel data from the CPU, converts it to a serial bit stream, inserts the appropriate characters or bits (based on the communication technique) and outputs a composite serial stream of data on the TxD output pin.

### Modem Control

The modem control section provides interfacing for three input signals and three output signals used for "handshaking" and status indication between the CPU and a modem.

### SYN/DLE Control

This section contains control circuitry and three 8-bit registers storing the SYN1, SYN2, and DLE characters provided by the CPU. These registers are used in the synchronous mode of operation to provide the characters required for synchronization, idle fill and data transparency.

**Table 1. Baud Rate Generator Characteristics  
SCN2661A (BRCLK = 4.9152MHz)**

MR23 - 20	BAUD RATE	ACTUAL FREQUENCY 16× CLOCK	PERCENT ERROR	DIVISOR
0000	50	0.8kHz	—	6144
0001	75	1.2	—	4096
0010	110	1.7598	-0.01	2793
0011	134.5	2.152	—	2284
0100	150	2.4	—	2048
0101	200	3.2	—	1536
0110	300	4.8	—	1024
0111	600	9.6	—	512
1000	1050	16.8329	0.196	292
1001	1200	19.2	—	256
1010	1800	28.7438	-0.19	171
1011	2000	31.9168	-0.26	154
1100	2400	38.4	—	128
1101	4800	76.8	—	64
1110	9600	153.6	—	32
1111	19200	307.2	—	16

**SCN2661B (BRCLK = 4.9152MHz)**

MR23 - 20	BAUD RATE	ACTUAL FREQUENCY 16× CLOCK	PERCENT ERROR	DIVISOR
0000	45.5	0.7279kHz	0.005	6752
0001	50	0.8	—	6144
0010	75	1.2	—	4096
0011	110	1.7598	-0.01	2793
0100	134.5	2.152	—	2284
0101	150	2.4	—	2048
0110	300	4.8	—	1024
0111	600	9.6	—	512
1000	1200	19.2	—	256
1001	1800	28.7438	-0.19	171
1010	2000	31.9168	-0.26	154
1011	2400	38.4	—	128
1100	4800	76.8	—	64
1101	9600	153.6	—	32
1110	19200	307.2	—	16
1111	38400	614.4	—	8

**SCN2661C (BRCLK = 5.0688MHz)**

MR23 - 20	BAUD RATE	ACTUAL FREQUENCY 16× CLOCK	PERCENT ERROR	DIVISOR
0000	50	0.8kHz	—	6336
0001	75	1.2	—	4224
0010	110	1.76	—	2880
0011	134.5	2.1523	0.016	2355
0100	150	2.4	—	2112
0101	300	4.8	—	1056
0110	600	9.6	—	528
0111	1200	19.2	—	264
1000	1800	28.8	—	176
1001	2000	32.081	0.253	158
1010	2400	38.4	—	132
1011	3600	57.6	—	88
1100	4800	76.8	—	66
1101	7200	115.2	—	44
1110	9600	153.6	—	33
1111	19200	316.8	3.125	16

#### NOTE:

16× clock is used in asynchronous mode. In synchronous mode, clock multiplier is 1× and BRG can be used only for Tx.

# Enhanced Programmable Communications Interface (EPCI)

SCN2661/SCN68661

## OPERATION

The functional operation of the SCN2661 is programmed by a set of control words supplied by the CPU. These control words specify items such as synchronous or asynchronous mode, baud rate, number of bits per character, etc. The programming procedure is described in the EPCI programming section of the data sheet.

After programming, the EPCI is ready to perform the desired communications functions. The receiver performs serial to parallel conversion of data received from a modem or equivalent device. The transmitter converts parallel data received from the CPU to a serial bit stream. These actions are accomplished within the framework specified by the control words.

### Receiver

The SCN2661 is conditioned to receive data when the  $\overline{\text{DCD}}$  input is low and the RxEN bit in the command register is true. In the asynchronous mode, the receiver looks for a high-to-low (mark to space) transition of the start bit on the RxD input line. If a transition is detected, the state of the RxD line is sampled again after a delay of one-half of a bit time. If RxD is now high, the search for a valid start bit is begun again. If RxD is still low, a valid start bit is assumed and the receiver continues to sample the input line at one bit time intervals until the proper number of data bits, the parity bit, and one stop bit have been assembled. The data are then transferred to the receive data holding register, the RxRDY bit in the status register is set, and the  $\overline{\text{RxRDY}}$  output is asserted. If the character length is less than 8 bits, the high order unused bits in the holding register are set to zero. The parity error, framing error, and overrun error status bits are strobed into the status register on the positive going edge of  $\overline{\text{RxC}}$  corresponding to the received character boundary. If the stop bit is present, the receiver will immediately begin its search for the next start bit. If the stop bit is absent (framing error), the receiver will interpret a space as a start bit if it persists into the next bit time interval. If a break condition is detected (RxD is low for the entire character as well as the stop bit), only one character consisting of all zeros (with the FE status bit SR5 set) will be transferred to the holding register. The RxD input must return to a high condition before a search for the next start bit begins.

Pin 25 can be programmed to be a break detect output by appropriate setting of MR27 - MR24. If so, a detected break will cause that pin to go high. When RxD returns to mark for one RxC time, pin 25 will go low. Refer to the Break Detection Timing Diagram.

Table 2. CPU-Related Signals

PIN NAME	PIN NO.	INPUT/OUTPUT	FUNCTION
RESET	21	I	A high on this input performs a master reset on the 2661. This signal asynchronously terminates any device activity and clears the mode, command and status registers. The device assumes the idle state and remains there until initialized with the appropriate control words.
A0, A1	12, 10	I	Address lines used to select internal EPCI registers.
$\overline{\text{R/W}}$	13	I	Read command when low, write command when high.
$\overline{\text{CE}}$	11	I	Chip enable command. When low, indicates that control and data lines to the EPCI are valid and that the operation specified by the $\overline{\text{R/W}}$ , A1 and A0 inputs should be performed. When high, places the D0 - D7 lines in the 3-State condition.
D0 - D7	27, 28, 1, 2, 5 - 8	I/O	8-bit, 3-State data bus used to transfer commands, data and status between EPCI and the CPU. D0 is the least significant bit, D7 the most significant bit.
$\overline{\text{TxRDY}}$	15	O	This output is the complement of status register bit SR0. When low, it indicates that the transmit data holding register (THR) is ready to accept a data character from the CPU. It goes high when the data character is loaded. This output is valid only when the transmitter is enabled. It is an open drain output which can be used as an interrupt to the CPU.
$\overline{\text{RxRDY}}$	14	O	This output is the complement of status register bit SR1. When low, it indicates that the receive data holding register (RHR) has a character ready for input to the CPU. It goes high when the RHR is read by the CPU, and also when the receiver is disabled. It is an open drain output which can be used as an interrupt to the CPU.
$\overline{\text{TxEMT/}}/$ $\overline{\text{DSCHG}}$	18	O	This output is the complement of status register bit SR2. When low, it indicates that the transmitter has completed serialization of the last character loaded by the CPU, or that a change of state of the $\overline{\text{DSR}}$ or $\overline{\text{DCD}}$ inputs has occurred. This output goes high when the status register is read by the CPU, if the TxEMT condition does not exist. Otherwise, the THR must be loaded by the CPU for this line to go high. It is an open drain output which can be used as an interrupt to the CPU. See Status Register (SR2) for details.

When the EPCI is initialized into the synchronous mode, the receiver first enters the hunt mode on a 0 to 1 transition of RxEN (CR2). In this mode, as data are shifted into the receiver shift register a bit at a time, the contents of the register are compared to the contents of the SYN1 register. If the two are not equal,

the next bit is shifted in and the comparison is repeated. When the two registers match, the hunt mode is terminated and character assembly mode begins. If single SYN operation is programmed, the SYN DETECT status bit is set. If double SYN operation is programmed, the first character assembled after SYN1

# Enhanced Programmable Communications Interface (EPCI)

SCN2661/SCN68661

must be SYN2 in order for the SYN DETECT bit to be set. Otherwise, the EPCI returns to the hunt mode (Note that the sequence SYN1 - SYN1 - SYN2 will not achieve synchronization). When synchronization has been achieved, the EPCI continues to assemble characters and transfer them to the holding register, setting the RxRDY status bit and asserting the RxRDY output each time a character is transferred. The PE and OE status bits are set as appropriate. Further receipt of the appropriate SYN sequence sets the SYN DETECT status bit. If the SYN stripping mode is commanded, SYN characters are not transferred to the holding register. Note that the SYN characters used to establish initial synchronization are not transferred to the holding register in any case.

External jam synchronization can be achieved via pin 9 by appropriate setting of MR27 - MR24. When pin 9 is an XSYNC input, the internal SYN1, SYN1 - SYN2, and DLE - SYN1 detection is disabled. Each positive going signal on XSYNC will cause the receiver to establish synchronization on the rising edge of the next RxC pulse. Character assembly will start with the RxD input at this edge. XSYNC may be lowered on the next rising edge of RxC. This external synchronization will cause the SYN DETECT status bit to be set until the status register is read. Refer to XSYNC timing diagram.

## Transmitter

The EPCI is conditioned to transmit data when the CTS input is low and the TxEN command register bit is set. The SCN2661 indicates to the CPU that it can accept a character for transmission by setting the TxRDY status bit and asserting the TxRDY output. When the CPU writes a character into the transmit data holding register, these conditions are negated. Data are transferred from the holding register to the transmit shift register when it is idle or has completed transmission of the previous character. The TxRDY conditions are then asserted again. Thus, one full character time of buffering is provided.

In the asynchronous mode, the transmitter automatically sends a start bit followed by the programmed number of data bits, the least significant bit being sent first. It then appends an optional odd or even parity bit and the programmed number of stop bits. If, following transmission of the data bits, a new character is not available in the transmit holding register, the TxD output remains in the marking (high) condition and the TxEMT/DSCHG output and its corresponding status bit are asserted. Transmission resumes when the CPU loads a new character into the holding register. The transmitter can be forced to output a continuous low (BREAK) condition by setting the send break command bit (CR3) high.

Table 3. Device Related Signals

PIN NAME	PIN NO.	INPUT/OUTPUT	FUNCTION
BRCLK	20	I	Clock input to the internal baud rate generator (see Table 1). Not required if external receiver and transmitter clocks are used.
RxC/BKDET	25	I/O	Receiver clock. If external receiver clock is programmed, this input controls the rate at which the character is to be received. Its frequency is 1X, 16X or 64X the baud rate, as programmed by mode register 1. Data are sampled on the rising edge of the clock. If internal receiver clock is programmed, this pin can be a 1X/16X clock or a break detect output pin.
TxC/XSYNC	9	I/O	Transmitter clock. If external transmitter clock is programmed, this input controls the rate at which the character is transmitted. Its frequency is 1X, 16X or 64X the baud rate, as programmed by mode register 1. The transmitted data changes on the falling edge of the clock. If internal transmitter clock is programmed, this pin can be a 1X/16X clock output or an external jam synchronization input.
RxD	3	I	Serial data input to the receiver. "Mark" is high, "space" is low.
TxD	19	O	Serial data output from the transmitter. "Mark" is high, "space" is low. Held in mark condition when the transmitter is disabled.
DSR	22	I	General purpose input which can be used for data set ready or ring indicator condition. Its complement appears as status register bit SR7. Causes a low output on TxEMT/DSCHG when its state changes if CR2 or CR0 = 1.
DCD	16	I	Data carrier detect input. Must be low in order for the receiver to operate. Its complement appears as status register bit SR6. Causes a low output on TxEMT/DSCHG when its state changes if CR2 or CR0 = 1. If DCD goes high while receiving, the RxC is internally inhibited.
CTS	17	I	Clear to send input. Must be low in order for the transmitter to operate. If it goes high during transmission, the character in the transmit shift register will be transmitted before termination.
DTR	24	O	General purpose output which is the complement of command register bit CR1. Normally used to indicate data terminal ready.
RTS	23	O	General purpose output which is the complement of command register bit CR5. Normally used to indicate request to send. See Command Register (CR5) for details.

# Enhanced Programmable Communications Interface (EPCI)

## SCN2661/SCN68661

**Table 4. SCN2661 Register Addressing**

CE	A <sub>1</sub>	A <sub>0</sub>	R/W	FUNCTION
1	X	X	X	3-State data bus
0	0	0	0	Read receive holding register
0	0	0	1	Write transmit holding register
0	0	1	0	Read status register
0	0	1	1	Write SYN1/SYN2/DLE registers
0	1	0	0	Read mode register 1/2
0	1	0	1	Write mode register 1/2
0	1	1	0	Read command register
0	1	1	1	Write command register

**NOTE:**  
See AC characteristics section for timing requirements.

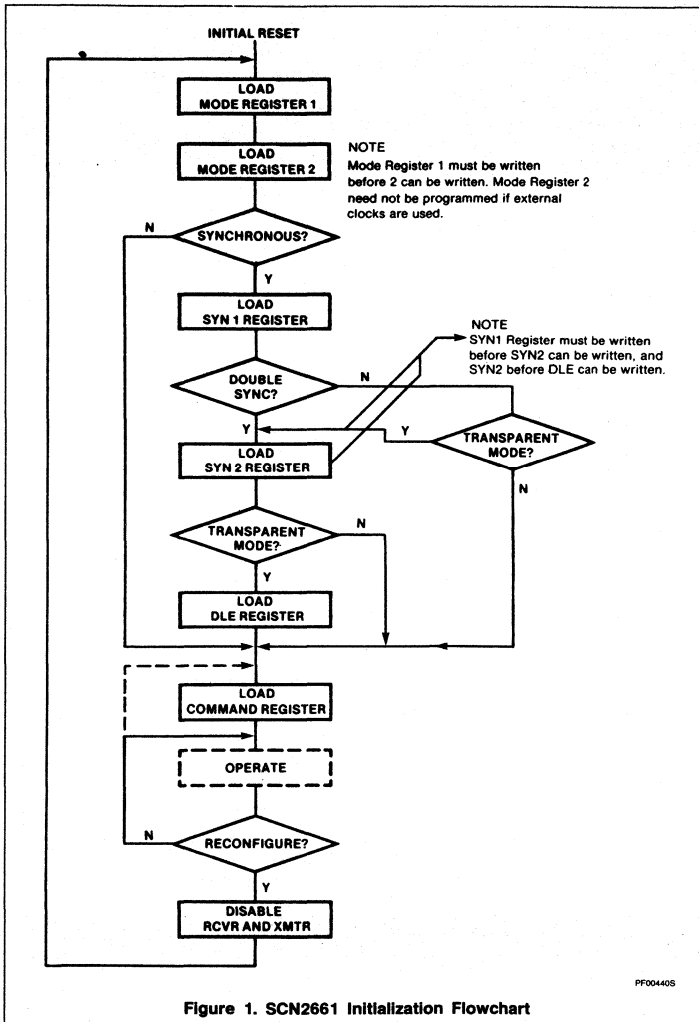

**Figure 1. SCN2661 Initialization Flowchart**

PF004405

In the synchronous mode, when the SCN2661 is initially conditioned to transmit, the Tx<sub>D</sub> output remains high and the TxRDY condition is asserted until the first character to be transmitted (usually a SYN character) is loaded by the CPU. Subsequent to this, a continuous stream of characters is transmitted. No extra bits (other than parity, if commanded) are generated by the EPCI unless the CPU fails to send a new character to the EPCI by the time the transmitter has completed sending the previous character. Since synchronous communication does not allow gaps between characters, the EPCI asserts TxEMT and automatically "fills" the gap by transmitting SYN1s, SYN1-SYN2 doublets, or DLE-SYN1 doublets, depending on the state of MR16 and MR17. Normal transmission of the message resumes when a new character is available in the transmit data holding register. If the send DLE bit in the command register is true, the DLE character is automatically transmitted prior to transmission of the message character in the THR.

### EPCI PROGRAMMING

Prior to initiating data communications, the SCN2661 operational mode must be programmed by performing write operations to the mode and command registers. In addition, if synchronous operation is programmed, the appropriate SYN/DLE registers must be loaded. The EPCI can be reconfigured at any time during program execution. A flowchart of the initialization process appears in Figure 1.

The internal registers of the EPCI are accessed by applying specific signals to the CE, R/W, A<sub>1</sub> and A<sub>0</sub> inputs. The conditions necessary to address each register are shown in Table 4.

The SYN1, SYN2, and DLE registers are accessed by performing write operations with the conditions A<sub>1</sub> = 0, A<sub>0</sub> = 1, and R/W = 1. The first operation loads the SYN1 register. The next loads the SYN2 register, and the third loads the DLE register. Reading or loading the mode registers is done in a similar manner. The first write (or read) operation addresses mode register 1, and a subsequent operation addresses mode register 2. If more than the required number of accesses are made, the internal sequencer recycles to point at the first register. The pointers are reset to SYN1 register and mode register 1 by a RESET input or by performing a read command register operation, but are unaffected by any other read or write operation.

The SCN2661 register formats are summarized in Tables 5, 6, 7 and 8. Mode registers 1 and 2 define the general operational characteristics of the EPCI, while the command register controls the operation within this basic framework. The EPCI indicates its sta-

# Enhanced Programmable Communications Interface (EPCI)

SCN2661/SCN68661

tus in the status register. These registers are cleared when a RESET input is applied.

## Mode Register 1 (MR1)

Table 5 illustrates mode register 1. Bits MR11 and MR10 select the communication format and baud rate multiplier. 00 specifies synchronous mode and 1× multiplier. 1×, 16×, and 64× multipliers are programmable for asynchronous format. However, the multiplier in asynchronous format applies only if the external clock input option is selected by MR24 or MR25.

MR13 and MR12 select a character length of 5, 6, 7 or 8 bits. The character length does not include the parity bit, if programmed, and does not include the start and stop bits in asynchronous mode.

MR14 controls parity generation. If enabled, a parity bit is added to the transmitted character and the receiver performs a parity check on incoming data. MR15 selects odd or even parity when parity is enabled by MR14.

In asynchronous mode, MR17 and MR16 select character framing of 1, 1.5, or 2 stop bits. (If 1× baud rate is programmed, 1.5 stop bits defaults to 1 stop bits on transmit.) In synchronous mode, MR17 controls the number of SYN characters used to establish synchronization and for character fill when the transmitter is idle. SYN1 alone is used if MR17 = 1, and SYN1 - SYN2 is used when MR17 = 0. If the transparent mode is specified by MR16, DLE - SYN1 is used for character fill and SYN detect, but the normal synchronization sequence is used to establish character sync. When transmitting, a DLE character in the transmit holding register will cause a second DLE character to be transmitted. This DLE stuffing eliminates the software DLE compare and stuff on each transparent mode data character. If the send DLE command (CR3) is active when a DLE is loaded into THR, only one additional DLE will be transmitted. Also, DLE stripping and DLE detect (with MR14 = 0) are enabled.

The bits in the mode register affecting character assembly and disassembly (MR12 - MR16) can be changed dynamically (during active receive/transmit operation). The character mode register affects both the transmitter and receiver; therefore in synchronous mode, changes should be made only in half-duplex mode (RxEN = 1 or TxEN = 1, but not both simultaneously = 1). In asynchronous mode, character changes should be made when RxEN and TxEN = 0 or when TxEN = 1 and the transmitter is marking in half-duplex mode (RxEN = 0).

To effect assembly/disassembly of the next received/transmitted character, MR12 - 15 must be changed within  $n$  bit times of the active going state of RxRDY/TxRDY. Transparent and non-transparent mode changes (MR16) must occur within  $n-1$  bit times of the character to be affected when the receiver or transmitter is active. ( $n$  = smaller of the new and old character lengths.)

**Table 5. Mode Register 1 (MR1)**

MR17	MR16	MR15	MR14	MR13	MR12	MR11	MR10
Sync/Async		Parity Type	Parity Control	Character Length		Mode and Baud Rate Factor	
<b>Async: Stop bit length</b> 00 = Invalid 01 = 1 stop bit 10 = 1½ stop bits 11 = 2 stop bits		0 = Odd 1 = Even	0 = Disabled 1 = Enabled	00 = 5 bits 01 = 6 bits 10 = 7 bits 11 = 8 bits		00 = Synchronous 1× rate 01 = Asynchronous 1× rate 10 = Asynchronous 16× rate 11 = Asynchronous 64× rate	
<b>Sync: Number of SYN char</b> 0 = Double SYN 1 = Single SYN	<b>Sync: Transparency control</b> 0 = Normal 1 = Transparent						

### NOTE:

Baud rate factor in asynchronous applies only if external clock is selected. Factor is 16× if internal clock is selected. Mode must be selected (MR11, MR10) in any case.

**Table 6. Mode Register 2 (MR2)**

MR27 - MR24										MR23 - MR20	
	TxC	RxC	Pin 9	Pin 25		TxC	RxC	Pin 9	Pin 25	Mode	Baud Rate Selection
0000	E	E	TxC	RxC	1000	E	E	XSYNC <sup>1</sup>	RxC/TxC	sync	See baud rates in Table 1
0001	E	I	TxC	1×	1001	E	I	TxC	BKDET	async	
0010	I	E	1×	RxC	1010	I	E	XSYNC <sup>1</sup>	RxC	sync	
0011	I	I	1×	1×	1011	I	I	1×	BKDET	async	
0100	E	E	TxC	RxC	1100	E	E	XSYNC <sup>1</sup>	RxC/TxC	sync	
0101	E	I	TxC	16×	1101	E	I	TxC	BKDET	async	
0110	I	E	16×	RxC	1110	I	E	XSYNC <sup>1</sup>	RxC	sync	
0111	I	I	16×	16×	1111	I	I	16×	BKDET	async	

### NOTES:

1. When Pin 9 is programmed as XSYNC input, SYN1, SYN1 - SYN2, and DLE - SYN1 detection is disabled.

E = External clock

I = Internal clock (BRG)

1× and 16× are clock outputs.



# Enhanced Programmable Communications Interface (EPCI)

SCN2661/SCN68661

Table 7. Command Register (CR)

CR7	CR6	CR5	CR4	CR3	CR2	CR1	CR0
<b>Operating Mode</b>		<b>Request To Send</b>	<b>Reset Error</b>	<b>Sync/ Async</b>	<b>Receive Control (RxEN)</b>	<b>Data Terminal Ready</b>	<b>Transmit Control (TxEN)</b>
00 = Normal operation 01 = Async: Automatic echo mode Sync: SYN and/or DLE stripping mode 10 = Local loopback 11 = Remote loopback		0 = Force $\overline{\text{RTS}}$ output high one clock time after TxSR serialization 1 = Force $\overline{\text{RTS}}$ output low	0 = Normal 1 = Reset error flags in status register (FE, OE, PE/DLE detect.)	<b>Async:</b> Force break 0 = Normal 1 = Force break  <b>Sync</b> Send DLE 0 = Normal 1 = SendDLE	0 = Disable 1 = Enable  Not applicable in	0 = Force $\overline{\text{DTR}}$ output high 1 = Force $\overline{\text{DTR}}$ output low	0 = Disable 1 = Enable

Table 8. Status Register (SR)

SR7	SR6	SR5	SR4	SR3	SR2	SR1	SR0
<b>Data Set Ready</b>	<b>Data Carrier Detect</b>	<b>FE/SYN Detect</b>	<b>Overrun</b>	<b>PE/DLE Detect</b>	<b>TxE<sub>M</sub>T D<sub>S</sub>CHG</b>	<b>RxRDY</b>	<b>TxRDY</b>
0 = DSR input is high 1 = DSR input is low	0 = DCD input is high 1 = DCD input is low	<b>Async:</b> 0 = Normal 1 = Framing error  <b>Sync:</b> 0 = Normal 1 = SYN detected	0 = Normal 1 = Overrun error  <b>Sync:</b>	<b>Async:</b> 0 = Normal 1 = Parity error  0 = Normal 1 = Parity error or DLE received	0 = Normal 1 = Change in DSR or DCD, or transmit shift register is empty	0 = Receive holding register empty 1 = Receive holding register has data	0 = Transmit holding register busy 1 = Transmit holding register empty

## Mode Register 2 (MR2)

Table 6 illustrates mode register 2. MR23, MR22, MR21 and MR20 control the frequency of the internal baud rate generator (BRG). Sixteen rates are selectable for each EPCI version (-1, -2, -3). Versions 1 and 2 specify a 4.9152MHz TTL input at BRCLK (pin 20); version 3 specifies a 5.0688MHz input which is identical to the Signetics 2651. MR23 - 20 are don't cares if external clocks are selected (MR25 - MR24 = 0). The individual rates are given in Table 1.

MR24 - MR27 select the receive and transmit clock source (either the BRG or an external input) and the function at Pins 9 and 25. Refer to Table 6.

## Command Register (CR)

Table 7 illustrates the command register. Bits CR0 (TxEN) and CR2 (RxEN) enable or disable the transmitter and receiver respectively. A 0-to-1 transition of CR2 forces start bit search (async mode) or hunt mode (sync mode) on the second  $\overline{\text{RxC}}$  rising edge. Disabling the receiver causes  $\overline{\text{RxRDY}}$  to go high (inactive). If the transmitter is disabled, it will complete the transmission of the character in the transmit shift register (if any) prior to terminating operation. The TxD output will then remain in the marking state (high) while

$\overline{\text{TxRDY}}$  and  $\overline{\text{TxE<sub>M</sub>T}}$  will go high (inactive). If the receiver is disabled, it will terminate operation immediately. Any character being assembled will be neglected. A 0 to 1 transition of CR2 will initiate start bit search (async) or hunt mode (sync).

Bits CR1 (DTR) and CR5 (RTS) control the  $\overline{\text{DTR}}$  and  $\overline{\text{RTS}}$  outputs. Data at the outputs are the logical complement of the register data.

In asynchronous mode, setting CR3 will force and hold the TxD output low (spacing condition) at the end of the current transmitted character. Normal operation resumes when CR3 is cleared. The TxD line will go high for at least one bit time before beginning transmission of the next character in the transmit data holding register. In synchronous mode, setting CR3 causes the transmission of the DLE register contents prior to sending the character in the transmit data holding register. Since this is a one time command, CR3 does not have to be reset by software. CR3 should be set when entering and exiting transparent mode and for all DLE - non-DLE character sequences.

Setting CR4 causes the error flags in the status register (SR3, SR4, and SR5) to be

cleared. This is a one time command. There is no internal latch for this bit.

When CR5 (RTS) is set, the  $\overline{\text{RTS}}$  pin is forced low. A 1-to-0 transition of CR5 will cause  $\overline{\text{RTS}}$  to go high (inactive) one TxC time after the last serial bit has been transmitted. If a 1-to-0 transition of CR5 occurs while data is being transmitted,  $\overline{\text{RTS}}$  will remain low (active) until both the THR and the transmit shift register are empty and then go high (inactive) one TxC time later.

The EPCI can operate in one of four sub-modes within each major mode (synchronous or asynchronous). The operational sub-mode is determined by CR7 and CR6. CR7 - CR6 = 00 is the normal mode, with the transmitter and receiver operating independently in accordance with the mode and status register instructions.

In asynchronous mode, CR7 - CR6 = 01 places the EPCI in the automatic echo mode. Clocked, regenerated received data are automatically directed to the TxD line while normal receiver operation continues. The receiver must be enabled (CR2 = 1), but the transmitter need not be enabled. CPU to receiver communications continues normally, but the CPU to transmitter link is disabled. Only the first character of a break condition is echoed.

# Enhanced Programmable Communications Interface (EPCI)

SCN2661/SCN68661

Table 9. SCN2661 EPCI vs SCN2651 PCI

FEATURE	EPCI	PCI
1. MR2 Bit 6, 7	Control pins 9, 25	Not used
2. DLE detect — SR3	SR3 = 0 for DLE - DLE,  DLE - SYN1	SR3 = 1 for DLE - DLE,  DLE - SYN1
3. Reset of SR3, DLE detect	Second character after DLE, or receiver disable, or CR4 = 1	Receiver disable, or CR4 = 1
4. Send DLE - CR3	One time command	Reset via CR3 on next TxRDY
5. DLE stuffing in transparent mode	Automatic DLE stuffing when DLE is loaded except if CR3 = 1	None
6. SYN1 stripping in double sync non-transparent mode	All SYN1	First SYN1 of pair
7. Baud rate versions	Three	One
8. Terminate ASYNC transmission (drop RTS)	Reset CR5 in response to TxEMT changing from 1 to 0	Reset CR0 when TxEMT goes from 1 to 0. Then reset CR5 when TxEMT goes from 1 to 0
9. Break detect	Pin 25 <sup>1</sup>	FE and null character
10. Stop bit searched	One	Two
11. External jam sync	Pin 9 <sup>2</sup>	No
12. Data bus timing	Improved over 2651	—
13. Data bus drivers	Sink 2.2mA Source 400μA	Sink 1.6mA Source 100μA

**NOTES:**

1. Internal BRG used for RxC.
2. Internal BRG used for TxC.

The TxD output will go high until the next valid start is detected. The following conditions are true while in automatic echo mode:

1. Data assembled by the receiver are automatically placed in the transmit holding register and retransmitted by the transmitter on the TxD output.
2. The transmitter is clocked by the receive clock.
3. TxRDY output = 1.
4. The TxEMT/DSCHG pin will reflect only the data set change condition.
5. The TxEN command (CR0) is ignored.

In synchronous mode, CR7 - CR6 = 01 places the EPCI in the automatic SYN/DLE stripping mode. The exact action taken depends on the setting of bits MR17 and MR16:

1. In the non-transparent, single SYN mode (MR17 - MR16 = 10), characters in the data stream matching SYN1 are not transferred to the receive data holding register (RHR).
2. In the non-transparent, double SYN mode (MR17 - MR16 = 00), characters in the data stream matching SYN1, or SYN2 if immediately preceded by SYN1, are not transferred to the RHR.

3. In transparent mode (MR16 = 1), characters in the data stream matching DLE, or SYN1 if immediately preceded by DLE, are not transferred to the RHR. However, only the first DLE of a DLE-DLE pair is stripped.

Note that automatic stripping mode does not affect the setting of the DLE detect and SYN detect status bits (SR3 and SR5).

Two diagnostic sub-modes can also be configured. In local loopback mode (CR7 - CR6 = 10), the following loops are connected internally:

1. The transmitter output is connected to the receiver input.
2. DTR is connected to DCD and RTS is connected to CTS.
3. The receiver is clocked by the transmit clock.
4. The DTR, RTS and Tx̄D outputs are held high.
5. The CTS, DCD, DSR and Rx̄D inputs are ignored.

Additional requirements to operate in the local loopback mode are that CR0 (TxEN), CR1 (DTR), and CR5 (RTS) must be set to 1. CR2 (RxEN) is ignored by the EPCI.

The second diagnostic mode is the remote loopback mode (CR7 - CR6 = 11). In this mode:

1. Data assembled by the receiver are automatically placed in the transmit holding register and retransmitted by the transmitter on the TxD output.
2. The transmitter is clocked by the receive clock.
3. No data are sent to the local CPU, but the error status conditions (PE, FE) are set.
4. The RxRDY, TxRDY, and TxEMT/DSCHG outputs are held high.
5. CR0 (TxEN) is ignored.
6. All other signals operate normally.

**Status Register**

The data contained in the status register (as shown in Table 8) indicate receiver and transmitter conditions and modem/data set status.

SR0 is the transmitter ready (TxRDY) status bit. It, and its corresponding output, are valid only when the transmitter is enabled. If equal to 0, it indicates that the transmit data holding register has been loaded by the CPU and the data has not been transferred to the transmit shift register. If set equal to 1, it indicates that the holding register is ready to accept data from the CPU. This bit is initially set when the transmitter is enabled by CR0, unless a character has previously been loaded into the holding register. It is not set when the automatic echo or remote loopback modes are programmed. When this bit is set, the TxRDY output pin is low. In the automatic echo and remote loopback modes, the output is held high.

SR1, the receiver ready (RxRDY) status bit, indicates the condition of the receive data holding register. If set, it indicates that a character has been loaded into the holding register from the receive shift register and is ready to be read by the CPU. If equal to zero, there is no new character in the holding register. This bit is cleared when the CPU reads the receive data holding register or when the receiver is disabled by CR2. When set, the RxRDY output is low.

The TxEMT/DSCHG bit, SR2, when set, indicates either a change of state of the DSR or DCD inputs (when CR2 or CR0 = 1) or that the transmit shift register has completed transmission of a character and no new character has been loaded into the transmit data holding register. Note that in synchronous mode this bit will be set even though the appropriate "fill" character is transmitted. TxEMT will not go active until at least one character has been transmitted. It is cleared by loading the transmit data holding register. The DSCHG condition is enabled when TxEN = 1 or RxEN = 1. It is cleared when the

# Enhanced Programmable Communications Interface (EPCI)

SCN2661/SCN68661

status register is read by the CPU. If the status register is read twice and SR2 = 1 while SR6 and SR7 remain unchanged, then a TxEMT condition exists. When SR2 is set, the  $\overline{\text{TxEMT}}/\text{DSCHG}$  output is low.

SR3, when set, indicates a received parity error when parity is enabled by MR14. In synchronous transparent mode (MR16 = 1), with parity disabled, it indicates that a character matching DLE register was received and the present character is neither SYN1 nor DLE. This bit is cleared when the next character following the above sequence is loaded into RHR, when the receiver is disabled, or by a reset error command, CR4.

The overrun error status bit, SR4, indicates that the previous character loaded into the receive holding register was not read by the CPU at the time a new received character was transferred into it. This bit is cleared when the receiver is disabled or by the reset error command, CR4.

In asynchronous mode, bit SR5 signifies that the received character was not framed by a stop bit; i.e., only the first stop bit is checked. If RHR = 0 when SR5 = 1, a break condition is present. In synchronous nontransparent mode (MR16 = 0), it indicates receipt of the SYN1 character in single SYN mode or the SYN1 - SYN2 pair in double SYN mode. In

synchronous transparent mode (MR16 = 1), this bit is set upon detection of the initial synchronizing characters (SYN1 or SYN1 - SYN2) and, after synchronization has been achieved, when a DLE - SYN1 pair is received. The bit is reset when the receiver is disabled, when the reset error command is given in asynchronous mode, or when the status register is read by the CPU in the synchronous mode.

SR6 and SR7 reflect the conditions of the  $\overline{\text{DCD}}$  and  $\overline{\text{DSR}}$  inputs, respectively. A low input sets its corresponding status bit, and a high input clears it.

## ABSOLUTE MAXIMUM RATINGS<sup>1</sup>

SYMBOL	PARAMETER	RATING	UNIT
$T_A$	Operating ambient temperature <sup>2</sup>	Note 4	°C
$T_{\text{STG}}$	Storage temperature range	-65 to +150	°C
	All voltages with respect to ground <sup>3</sup>	-0.5 to +6.0	V

## DC ELECTRICAL CHARACTERISTICS<sup>4, 5, 6</sup>

SYMBOL	PARAMETER	TEST CONDITIONS	LIMITS			UNIT
			Min	Typ	Max	
<b>Input voltage</b>						
$V_{\text{IL}}$ $V_{\text{IH}}$	Low High		2		0.8	V
<b>Output voltage</b>						
$V_{\text{OL}}$ $V_{\text{OH}}^7$	Low High	$I_{\text{OL}} = 2.2\text{mA}$ $I_{\text{OH}} = -400\mu\text{A}$	2.4		0.4	V
$I_{\text{IL}}$	Input leakage current	$V_{\text{IN}} = 0$ to 5.5V			10	$\mu\text{A}$
<b>3-State output leakage current</b>						
$I_{\text{LH}}$ $I_{\text{LL}}$	Data bus high Data bus low	$V_{\text{O}} = 4\text{V}$ $V_{\text{O}} = 0.45\text{V}$			10 10	$\mu\text{A}$
$I_{\text{CC}}$	Power supply current				150	mA

## CAPACITANCE $T_A = 25^\circ\text{C}$ , $V_{\text{CC}} = 0\text{V}$

SYMBOL	PARAMETER	TEST CONDITIONS	LIMITS			UNIT
			Min	Typ	Max	
<b>Capacitance</b>						
$C_{\text{IN}}$ $C_{\text{OUT}}$ $C_{\text{I/O}}$	Input Output Input/Output	$f_{\text{C}} = 1\text{MHz}$ Unmeasured pins tied to ground			20 20 20	pF

# Enhanced Programmable Communications Interface (EPCI)

SCN2661/SCN68661

**AC ELECTRICAL CHARACTERISTICS**<sup>4, 5, 6</sup>

SYMBOL	PARAMETER	TEST CONDITIONS	LIMITS			UNIT
			Min	Typ	Max	
<b>Pulse width</b>						
t <sub>RES</sub>	Reset		1000			ns
t <sub>CE</sub>	Chip enable		250			
<b>Setup and hold time</b>						
t <sub>AS</sub>	Address setup		10			ns
t <sub>AH</sub>	Address hold		10			
t <sub>CS</sub>	R/W control setup		10			
t <sub>CH</sub>	R/W control hold		10			
t <sub>DS</sub>	Data setup for write		150			
t <sub>DH</sub>	Data hold for write		10			
t <sub>RXS</sub>	RX data setup		300			
t <sub>RXH</sub>	RX data hold		350			
t <sub>DD</sub>	Data delay time for read	C <sub>L</sub> = 150pF			200	ns
t <sub>DF</sub>	Data bus floating time for read	C <sub>L</sub> = 150pF			100	
t <sub>CED</sub>	CE to CE delay		600			
<b>Input clock frequency</b>						
f <sub>BRG</sub>	Baud rate generator (2661A, B)		1	4.9152	4.9202	MHz
f <sub>BRG</sub>	Baud rate generator (2661C)		1	5.0688	5.0738	
f <sub>R/T</sub> <sup>10</sup>	TxC or RxC		DC		1	
<b>Clock width</b>						
t <sub>BRH</sub> <sup>9</sup>	Baud rate high (2661A, B)		75			ns
t <sub>BRH</sub> <sup>9</sup>	Baud rate high (2661C)		70			
t <sub>BRL</sub> <sup>9</sup>	Baud rate low (2661A, B)		75			
t <sub>BRL</sub> <sup>9</sup>	Baud rate low (2661C)		70			
t <sub>R/TH</sub>	TxC or RxC high		480			
t <sub>R/TL</sub> <sup>10</sup>	TxC or RxC low		480			
t <sub>TXD</sub>	TxD delay from falling edge of TxC	C <sub>L</sub> = 150pF			650	ns
t <sub>TCS</sub>	Skew between TxD changing and falling edge of TxC output <sup>8</sup>	C <sub>L</sub> = 150pF		0		

**NOTES:**

- Stresses above those listed under Absolute Maximum Ratings may cause permanent damage to the device. This is a stress rating only and functional operation of the device at these or at any other condition above those indicated in the operation section of this specification is not implied.
- For operating at elevated temperatures, the device must be derated based on +150°C maximum junction temperature.
- This product includes circuitry specifically designed for the protection of its internal devices from the damaging effects of excessive static charge. Nonetheless, it is suggested that conventional precautions be taken to avoid applying any voltages larger than the rated maxima.
- Parameters are valid over operating temperature range unless otherwise specified. See ordering code table for applicable temperature range and operating supply range.
- All voltage measurements are referenced to ground. All time measurements are at the 50% level for inputs (except t<sub>BRH</sub> and t<sub>BRL</sub>) and at 0.8V and 2V for outputs. Input levels swing between 0.4V and 2.4V, with a transition time of 20ns maximum.
- Typical values are at +20°C, typical supply voltages and typical processing parameters.
- INTR, TxRDY, RxRDY and TxEMT/DSCHG outputs are open drain.
- Parameter applies when internal transmitter clock is used.
- Under test conditions of 5.0688MHz f<sub>BRG</sub> (2661C) and 4.9152MHz f<sub>BRG</sub> (2661A,B), t<sub>BRH</sub> and t<sub>BRL</sub> measured at V<sub>IH</sub> and V<sub>IL</sub>, respectively.
- In asynchronous local loopback mode, using 1× clock, the following parameters apply: f<sub>R/T</sub> = 0.83MHz max and t<sub>R/TL</sub> = 700ns min.

# Enhanced Programmable Communications Interface (EPCI)

## SCN2661/SCN68661

### TIMING DIAGRAMS

2

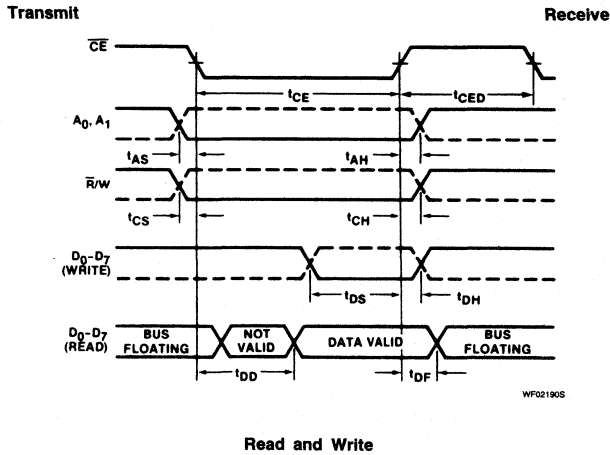
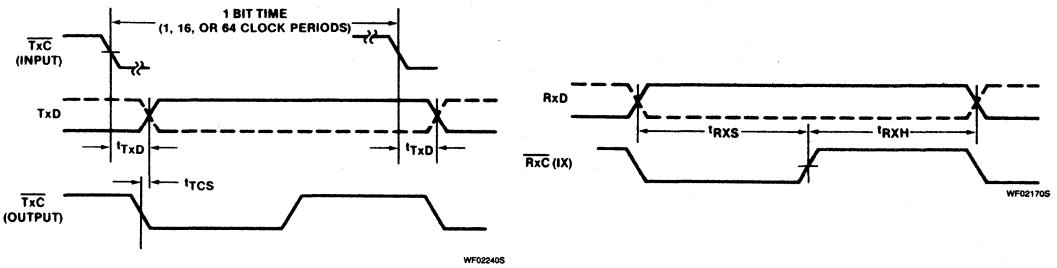
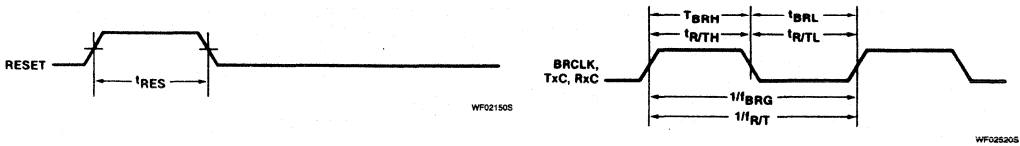

# Enhanced Programmable Communications Interface (EPCI)

SCN2661/SCN68661

## TIMING DIAGRAMS (Continued)

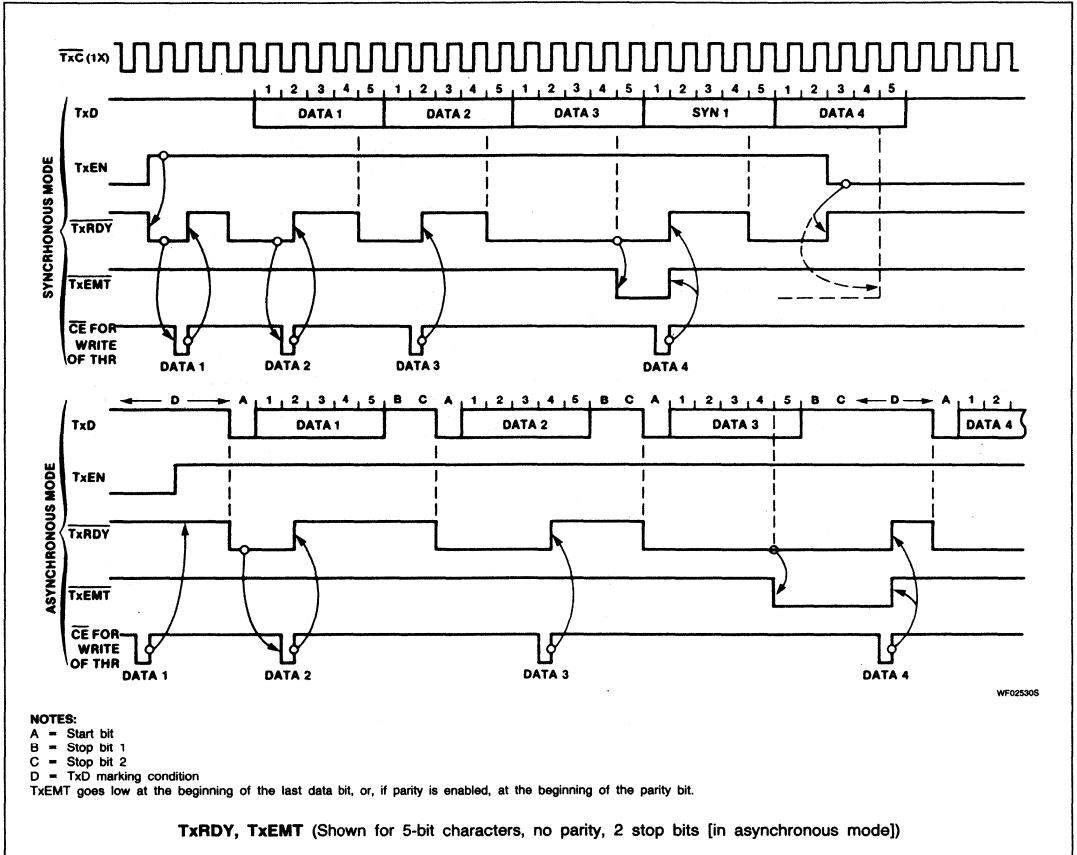

WF025305

# Enhanced Programmable Communications Interface (EPCI)

## SCN2661/SCN68661

### TIMING DIAGRAMS (Continued)

2

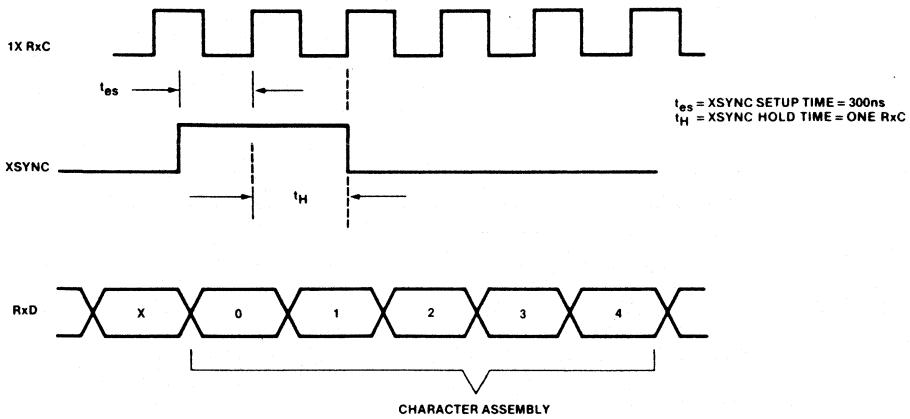

### External Synchronization With XSYNC

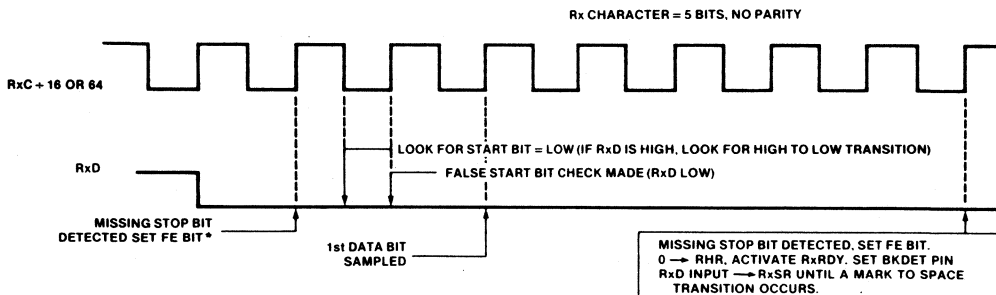

**NOTE:**

\* If the stop bit is present, the start bit search will commence immediately.

### Break Detection Timing

# Enhanced Programmable Communications Interface (EPCI)

SCN2661/SCN68661

## TIMING DIAGRAMS (Continued)

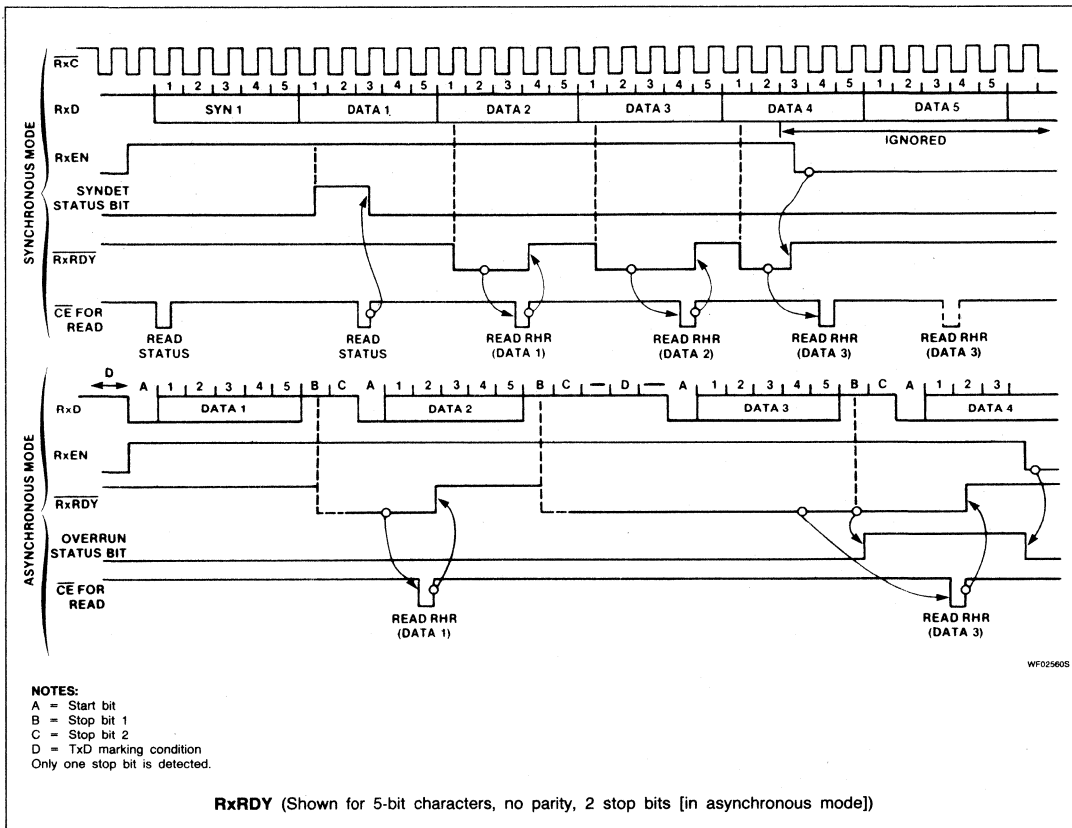



# Enhanced Programmable Communications Interface (EPCI)

SCN2661/SCN68661

## TYPICAL APPLICATIONS

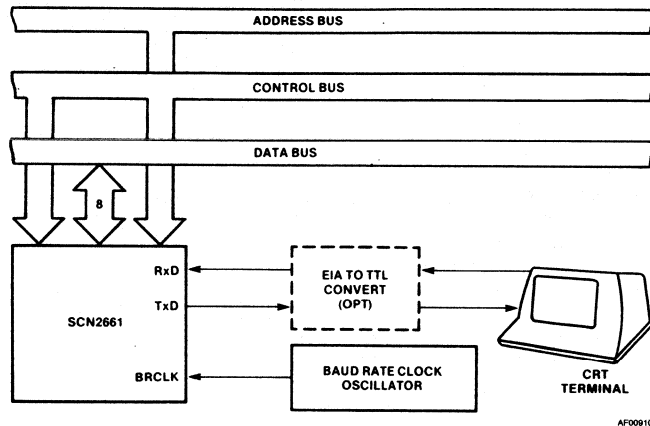

Asynchronous Interface to CRT Terminal

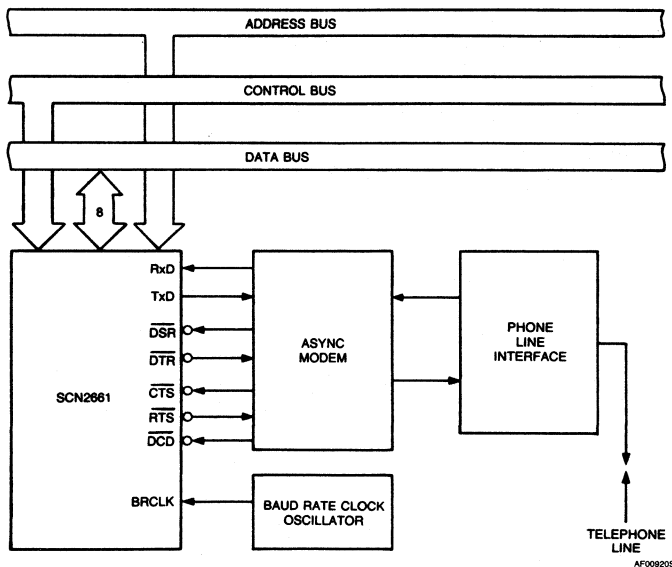

Asynchronous Interface to Telephone Lines

# Enhanced Programmable Communications Interface (EPCI)

SCN2661/SCN68661

## TYPICAL APPLICATIONS (Continued)

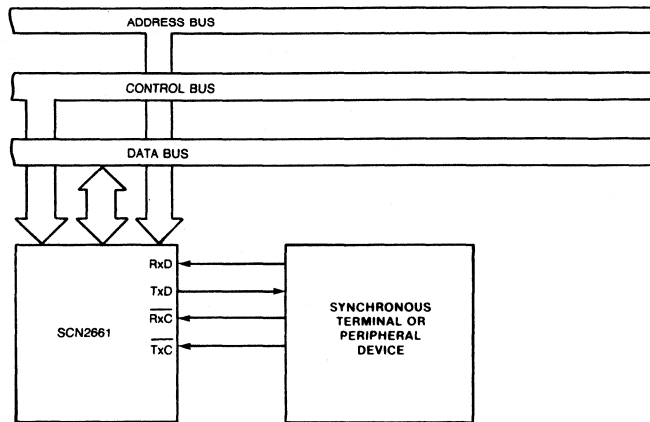

AF009205

Synchronous Interface to Terminal or Peripheral Device

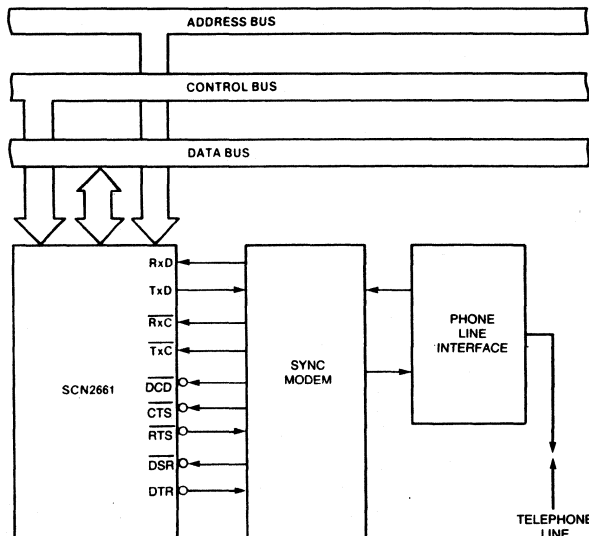

AF009405

Synchronous Interface to Telephone Lines

# SCN2671

## Programmable Keyboard and Communication Controller (PKCC)

Microprocessor Products

Product Specification

### DESCRIPTION

The Signetics SCN2671 Programmable Keyboard and Communications Controller (PKCC) is a MOS LSI device which provides a versatile keyboard encoder and an independent full-duplex asynchronous communications controller. It is intended for use in microprocessor based systems and provides an 8-bit data bus interface.

The keyboard encoder handles the scanning, debounce, and encoding of a keyboard matrix with a maximum of 128 keys. It provides four levels of key encoding corresponding to the separate SHIFT and CONTROL input combinations. Four keyboard rollover modes can be programmed including provisions for up to 16 latched keys. Control outputs are provided for interfacing with contact or capacitive keyboards. An 8-bit keyboard status register provides status information to the CPU.

The receiver section of the communications controller accepts serial data from the RxD pin and converts it to parallel data characters. Simultaneously, the transmitter section accepts parallel data from the data bus and outputs serialized data onto the TxD pin. Received data is checked for parity and framing errors, and break conditions are flagged. Character lengths can be programmed as 5, 6, 7, or 8 bits not including parity, start or stop bits. An internal baud rate generator (BRG) with 16 divider ratios can be used to derive the receive and/or transmit clocks. The BRG can accept an external clock or operate directly from a crystal. An 8-bit communications status register provides status information to the CPU.

### FEATURES

- Keyboard Interface
  - Contact or capacitive keyboard
  - Up to 128 keys on an 8 × 16 matrix
  - Encoded or unencoded operation
  - Four code levels per key
  - Latched key option — separate depress and release codes
  - Programmable scan rate and debounce time
  - Programmable rollover modes
  - Programmable auto-repeat for selected keys
  - Tone output — two frequencies
- Asynchronous communication interface
  - Internal baud rate generator — 16 rates
  - Full duplex operation
  - Detection of start and end of break
  - Programmable break generation
  - Programmable character parameters
  - Auto-echo and maintenance loopback modes
- Polled or interrupt operation
- Interrupt priority controller and vector generator
- Operates directly from crystal or external clocks
- TTL compatible
- Single +5V power supply

### APPLICATIONS

- CRT terminals
- Hard copy terminals
- Word processing systems
- Data entry terminals
- Small business computers

### PIN CONFIGURATIONS

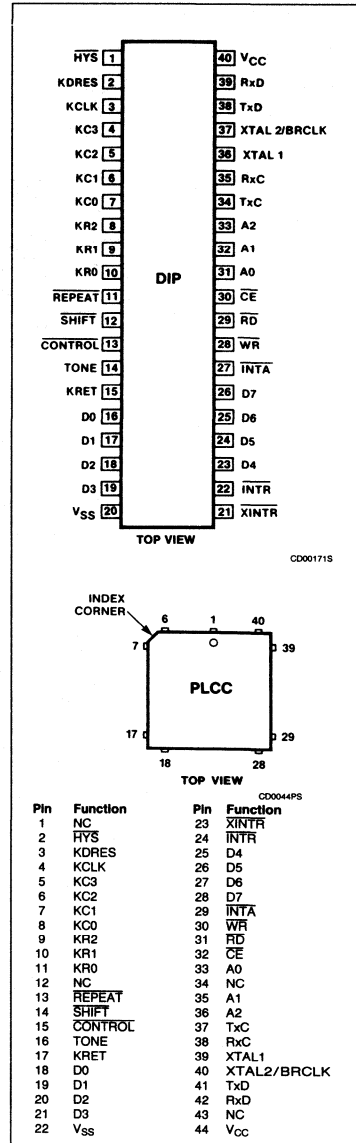

# Programmable Keyboard and Communication Controller (PKCC)

SCN2671

## ORDERING INFORMATION

PACKAGES	$V_{CC} = +5V \pm 5\%$ , $T_A = 0^\circ C$ to $+70^\circ C$
Ceramic DIP	SCN2671AC1140
Plastic DIP	SCN2671AC1N40
Plastic LCC	SCN2671AC1A44

## BLOCK DIAGRAM

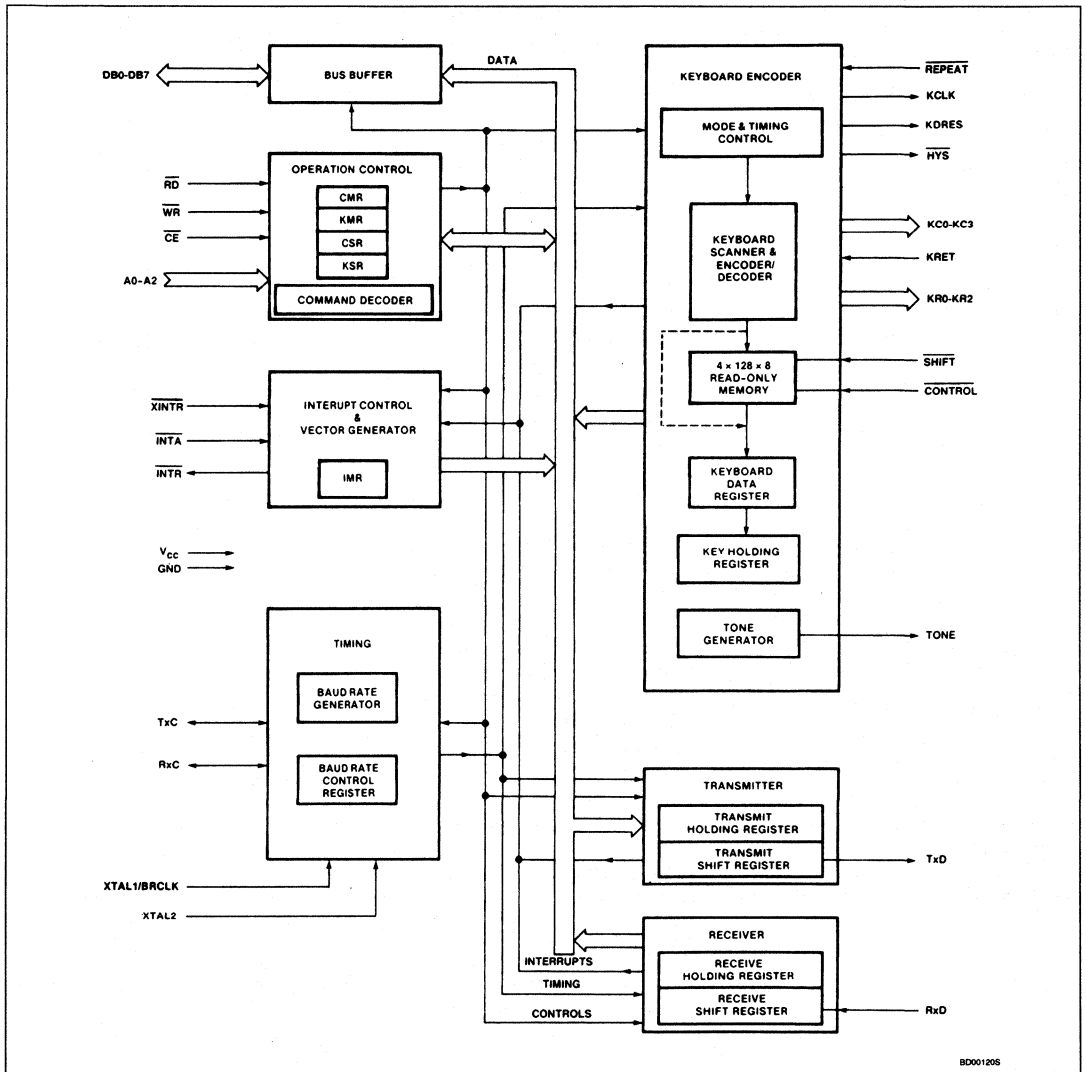

BD001206

# Programmable Keyboard and Communication Controller (PKCC)

SCN2671

## PIN DESCRIPTION

MNEMONIC	PIN NO.		TYPE	NAME AND FUNCTION
	DIP	PLCC		
D0 - D7	16 - 19, 23 - 26	18 - 21, 25 - 28	I/O	<b>Data Bus:</b> 8-bit 3-State bidirectional data bus. All data, command and status transfers are made using this bus. D0 is the least significant bit; D7 is the most significant bit.
A0 - A2	31 - 33	33, 35, 36	I	<b>Address Lines:</b> Used to select internal PKCC registers or commands.
$\overline{RD}$	29	31	I	<b>Read Strobe:</b> When low, gates the selected PKCC register onto the data bus if $\overline{CE}$ is also low.
$\overline{WR}$	28	30	I	<b>Write Strobe:</b> When low, gates the contents of the data bus into the selected PKCC register if $\overline{CE}$ is also low.
$\overline{CE}$	30	32	I	<b>Chip Enable:</b> When high, places the D0 - D7 output drivers in a 3-State condition. If $\overline{CE}$ is low, data transfers are enabled in conjunction with the $\overline{RD}$ and $\overline{WR}$ inputs.
INTR	22	24	O	<b>Interrupt Request:</b> Several conditions may be programmed to request an interrupt to the CPU. It is an active low open-drain output. This pin will be inactive after power on reset or a master reset command.
$\overline{INTA}$	27	29	I	<b>Interrupt Acknowledge:</b> Used to indicate that an interrupt request has been accepted by the CPU. When $\overline{INTA}$ goes low, the PKCC outputs an 8-bit address vector on D0 - D7 corresponding to the highest priority interrupt currently active.
$\overline{XINTR}$	21	23	I	<b>External Interrupt:</b> An active low external interrupt input to the PKCC interrupt priority resolver.
TxC	34	37	I/O	<b>Transmitter Clock:</b> The function of this pin depends on bit 7 of the baud rate control register (BRR7). If external transmitter clock is selected (BRR7 = 0), it is an input for the transmitter clock. If internal transmitter clock is selected (BRR7 = 1), this pin is an output which is a multiple of the actual baud rate ( $1 \times$ , $16 \times$ ) as selected by BRR5. The data is transmitted on the falling edge of TxC. It is an input after power on and after master reset or communications reset commands.
RxC	35	38	I/O	<b>Receiver Clock:</b> The function of this pin depends on BRR6. If external receiver clock is selected (BRR6 = 0), it is an input for the receiver clock. If internal receiver clock is selected (BRR6 = 1), this pin is an output which is a multiple of the actual baud rate ( $1 \times$ , $16 \times$ ) as selected by BRR4. The received data is sampled on the rising edge of RxC. It is an input after power on and after master reset or communications reset commands.
TxD	38	41	O	<b>Transmitter Data:</b> This output is the transmitted serial data; the least significant bit is transmitted first. This pin is high after power on reset or a reset command that affects the transmitter.
RxD	39	42	I	<b>Receiver Data:</b> This input is the serial data input to the receiver. The least significant bit is received first.
XTAL1, XTAL2/BRCLK	36, 37	39, 40	I	<b>Connections for Crystal:</b> Provides an on-chip clock generator for the internal baud rate generator and the keyboard interface logic. If an external clock is provided, use XTAL2 as the clock input. See Figures 20 and 21. All timing parameters such as keyboard scan time, tone frequency, and baud rate assume a clock input at the specified BRG input frequency. If this frequency is different the timing parameters will vary proportionately.
KR0 - KR2	10 - 8	11 - 9	O	<b>Keyboard Row Scan:</b> Decoded externally; selects one of eight rows.
KC0 - KC3	7 - 4	8 - 5	O	<b>Keyboard Column Scan:</b> Decoded externally; selects one of 16 columns.
KRET	15	17	I	<b>Key Return:</b> An active high-level indicates that the key being scanned is closed.
SHIFT	12	14	I	<b>SHIFT Key:</b> Active low input from the SHIFT key. The combination of $\overline{SHIFT}$ and $\overline{CONTROL}$ inputs select one of four possible codes from the internal key encoding ROM.
$\overline{CONTROL}$	13	15	I	<b>CONTROL Key:</b> Active low input from the CONTROL key. The combination of $\overline{SHIFT}$ and $\overline{CONTROL}$ inputs select one of four possible codes from the internal key encoding ROM.
REPEAT	11	13	I	<b>REPEAT Key:</b> Active low input from the REPEAT key. Causes the key depression currently active to be repeated at a rate of approximately 15 times per second.
KCLK	3	4	O	<b>Keyboard Clock:</b> High frequency (approximately 400kHz) output used to scan capacitive keyboards.
KDRES	2	3	O	<b>Key Detect Reset:</b> Resets the analog detector before scanning a key. Used for capacitive keyboards.
HYS	1	2	O	<b>Hysteresis Output:</b> Sent to the analog detector for capacitive keyboard applications. A low indicates the key currently being scanned has been recognized on previous scan cycles.
tone	14	16	O	<b>Square Wave Output:</b> Used for tone generation.
V <sub>CC</sub>	40	44	I	<b>Power Supply:</b> +5V.
V <sub>SS</sub>	20	22	I	Ground.

# Programmable Keyboard and Communication Controller (PKCC)

SCN2671

The PKCC has an interrupt mask register to selectively enable certain keyboard and communications status bits to generate interrupts. Priority encoded interrupt vectoring is available. Upon receipt of an interrupt acknowledge, an interrupt vector will be output on D0 - D7 reflecting the source of the interrupt. The interrupt source can also be read from an interrupt status register.

## FUNCTIONAL DESCRIPTION

The PKCC consists of six major sections (see block diagram). These are the transmitter, receiver, timing, operation control, keyboard encoder, and a priority encoded interrupt control unit. These sections communicate with each other via an internal data bus and an internal control bus. The internal data bus interfaces to the microprocessor data bus via a bidirectional data bus buffer.

### Operation Control

This functional block stores configuration and operation commands from the CPU and generates appropriate signals to various internal sections to control the overall device operation. It contains read and write circuits to permit communications with the microprocessor via the data bus and contains mode registers KMR and CMR, the command decoder, and status registers KSR and CSR. Details of operating modes and status information are presented in the Operation section of this data sheet. The register addressing is specified in Table 1.

### Timing

The PKCC contains a baud rate generator (BRG) which is programmable to accept external transmit or receive clocks or to divide an external clock to perform data communications. The unit can generate 16 baud rates, any of which can be selected for full duplex operation. The external clock to the baud rate generator can be applied directly to the XTAL2 input (see Figure 21) or can be generated internally by connecting a crystal across the XTAL1, XTAL2 input pins. The clock input is also utilized by the keyboard encoder section. Thus, a clock must be provided even if external transmitter and receiver clocks are used.

### Receiver

The receiver accepts serial data on the RxD pin, converts this serial input to parallel format, checks for break conditions, framing and parity errors, and loads an "assembled" character in the receive holding register for access by the CPU.

### Transmitter

The transmitter accepts parallel data loaded by the CPU into the transmit holding register and converts it to a serial bit stream framed by the start bit, calculated parity bit (if speci-

**Table 1. Register Addressing**

CE	A2	A1	A0	RD/WR	FUNCTION
1	X	X	X	X	3-State data bus
0	0	0	0	WR	Reset command (see Table 6)
0	0	0	0	RD	Read interrupt status register (ISR)
0	0	0	1	RD, WR	Read/write communications mode register (CMR)
0	0	1	0	WR	Write transmit holding register (TxHR)
0	0	1	0	RD	Read receiver holding register (RxHR)
0	0	1	1	WR	Write baud rate mode register (BRR)
0	0	1	1	RD	Read communications status register (CSR)
0	1	0	0	RD, WR	Read/write interrupt mask register (IMR)
0	1	0	1	RD, WR	Read/write keyboard mode register (KMR)
0	1	1	0	RD	Read keyboard holding register (KHR)
0	1	1	1	RD	Read keyboard status register (KSR)
0	1	1	1	WR	Miscellaneous commands (see Description)

#### NOTE:

X = don't care.

fied), and stop bit(s). The composite serial stream of data is transmitted on the TxD output pin.

### Keyboard Encoder

The keyboard encoder provides encoded scanning signals for a matrix keyboard. Key depressions are detected on the KRET input. The debounced and verified key codes (or matrix addresses) are loaded into the key holding register for access by the CPU. Figures 1 and 2 illustrate the PKCC interface to contact and capacitive keyboards, respectively.

### Interrupt Control

The interrupt controller unit contains a software-programmable interrupt mask register which selectively enables status conditions from the keyboard encoder and communication controller to generate interrupts. The interrupts are priority encoded and individually generate an eight bit vector which is output on the data bus in response to a CPU interrupt acknowledge on the INTA input pin.

## OPERATION

### Keyboard Encoder

The keyboard is continuously scanned by KC0 - KC3 and KR0 - KR2 which are decoded externally to handle 128 possible keys (see Figures 1 and 2). KC0 - KC3 select one of 16 columns and KR0 - KR2 multiplex the eight row return lines into the KRET pin. Debouncing is accomplished by remembering a 1 state at the KRET pin when a key is being addressed and verifying it one scan later. Once the key is verified, a key code is loaded into the keyboard data register (KDR). If the keyboard holding register (KHR) is empty, the contents of the KDR will be transferred to the KHR immediately; if the KHR is full (i.e., the CPU has not read the previous key code), the transfer will be held off until the KHR is read. The data transfer to the KHR causes key-

board data ready (KRDY) to be set in the keyboard status register.

For capacitive keyboards, the high frequency output KCLK can be used to gate the column scan to the keyboard (see Figure 2). The key detector reset (KDRES) output resets the analog detector prior to scanning each key location. The output from the analog multiplexer is sensed and then latched in the analog detector. The HYS output controls the sense level. A 0 will lower the sense level causing hysteresis, and a 1 will raise the sense level with no hysteresis.

The REPEAT input enables the keyboard logic to recognize any key repeatedly, 15 times per second. Additionally, certain keys can be programmed to repeat automatically if depressed for more than one-half second.

A square wave is output on the TONE pin when the CPU issues a ring tone command to the PKCC.

### Keyboard Mode Register

Operating modes are selected by programming the keyboard mode register (KMR), see Figure 3. Bit KMR7 is used for testing the device. For normal operation, this bit should always be written to a 0. Bits KMR6 - KMR5 select the rollover modes for keyboard processing:

**N-key Rollover:** In this mode, the code corresponding to each key depression is loaded into the KDR as soon as that key is debounced, independent of the release of other keys. Two or more closures occurring within one scan cycle are considered to be simultaneous, which will set keyboard error in the keyboard status register (KSR1). As soon as the keyboard holding register is empty, the code in the KDR is transferred to the KHR and the KRDY status bit is set (KSRO).

**N-Key Rollover With Latched Keys:** This mode is the same as regular N-key rollover, except that the keys which are assigned to

# Programmable Keyboard and Communication Controller (PKCC)

## SCN2671

2

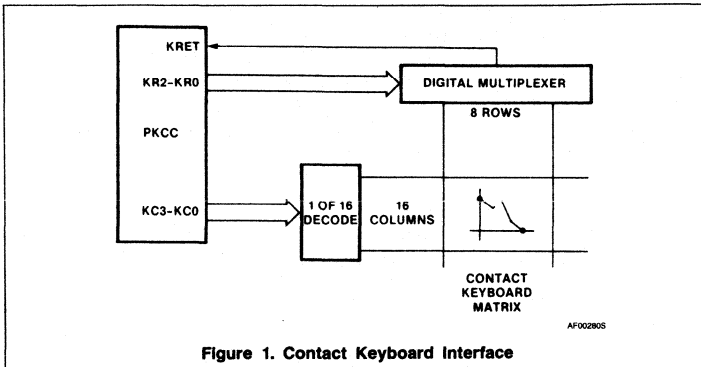

Figure 1. Contact Keyboard Interface

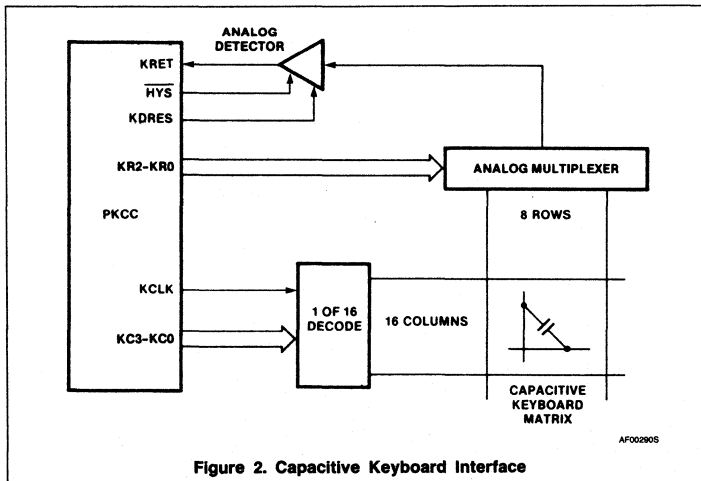

Figure 2. Capacitive Keyboard Interface

row 0 of the keyboard matrix (KR2 - KR0 = 000) produce a code both when depressed and when released. The codes are independent of the states of the inputs at SHIFT and CONTROL. If one or more of the latched keys are depressed when the keyboard is enabled (after a keyboard reset), the corresponding codes will be sent out as the keys are scanned and debounced. Note that simultaneous latched keys will not set KERR (KSR1) and that latched keys will not be auto-repeat and will not be affected by the REPEAT input.

**Two-Key Rollover:** The first key code is loaded into the KDR immediately and the second code is loaded only after the first key is released. Simultaneous keys will set KERR (KSR1), if three or more keys remain closed at any given time, the KERR bit will also be set. All keys must then be released before the next KRET will be processed.

**Two-Key Inhibit:** All keys must be released between keystrokes; otherwise, KERR (KSR1) will be set.

Bit KMR4 specifies the key encoding mode. Each key is assigned four 8-bit codes, corresponding to the states of the SHIFT and CONTROL inputs. If the encoded mode is programmed, the row/column address of the detected key is used to load one of the four key codes into the KDR. See Table 2 for key code assignments. If the non-encoded mode is programmed, the row/column address is loaded directly into the KDR with the following format:

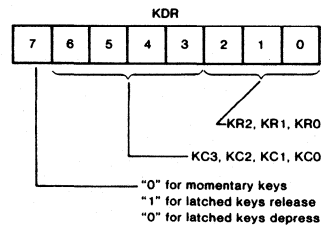

AF002805

# Programmable Keyboard and Communication Controller (PKCC)

SCN2671

Table 2. Standard Key Codes (HEX)

COLUMN (KC3 - KC0)	ROW (KR2 - KR0)									
	0	1	2	3	4	5	6	7		
0	E0	C0	1B ESC	09 HT	1F US	1A SUB	30 0	2B +		
	F0	D0	1B ESC	09 HT	1F US	1A SUB	30 0	3B .		
	E0	C0	1B ESC	09 HT	1F US	5A Z	30 0	2B +		
	F0	D0	1B ESC	09 HT	1F US	7A z	30 0	3B .		
1	E1	C1	21 !	11 DC1	01 SOH	18 CAN	3D =	2A *		
	F1	D1	31 1	11 DC1	01 SOH	18 CAN	2D =	3A .		
	E1	C1	21 !	51 Q	41 A	58 X	3D * =	2A *		
	F1	D1	31 1	71 q	61 a	78 x	2D * =	3A .		
2	E2	C2	22 "	17 ETB	13 DC3	03 ETX	1E RS	1F US		
	F2	D2	32 2	17 ETB	13 DC3	03 ETX	1E RS	1F US		
	E2	C2	22 "	57 W	53 S	43 C	7E ~	7F DEL		
	F2	D2	32 2	77 w	73 s	63 c	5E †	5F DEL		
3	E3	C3	23 #	05 ENQ	04 EOT	16 SYN	1C FS	1B ESC		
	F3	D3	33 3	05 ENQ	04 EOT	16 SYN	1C FS	1B ESC		
	E3	C3	23 #	45 E	44 D	56 V	7C .	7D }		
	F3	D3	33 3	65 e	64 d	76 v	5C \	5B [		
4	E4	C4	24 \$	12 DC2	06 ACK	02 STX	08 BS	1D GS		
	F4	D4	34 4	12 DC2	06 ACK	02 STX	08 BS	1D GS		
	E4	C4	24 \$	52 R	46 F	42 B	08 .	7D }		
	F4	D4	34 4	72 r	46 F	62 b	08 .	5D }		
5	E5	C5	25 %	14 DC4	07 BEL	0E SO	10 DLE	08 BS		
	F5	D5	35 5	14 DC4	07 BEL	0E SO	10 DLE	08 BS		
	E5	C5	25 %	54 T	47 G	4E N	50 P	08 BS		
	F5	D5	35 5	74 t	47 G	6E n	70 p	08 .		
6	E6	C6	26 &	19 EM	08 BS	0D CR	00 NUL	09 HT		
	F6	D6	36 6	19 EM	08 BS	0D CR	00 NUL	09 HT		
	E6	C6	26 &	59 Y	48 H	4D M	60 @	09 .		
	F6	D6	36 6	79 y	48 H	6D m	40 @	09 .		
7	E7	C7	27 .	15 NAK	0A LF	3C <	7F DEL	20 SP		
	F7	D7	37 7	15 NAK	0A LF	2C <	7F DEL	20 SP		
	E7	C7	27 .	55 U	4A J	3C <	7F DEL	20 .		
	F7	D7	37 7	75 u	6A j	2C <	7F DEL	20 .		
8	E8	C8	28 (	09 HT	0B VT	3E >	0A LF	0B VT		
	F8	D8	38 8	09 HT	0B VT	2E >	0A LF	0B VT		
	E8	C8	28 (	49 I	4B K	3E >	0A LF	0B .		
	F8	D8	38 8	69 i	6B k	2E >	0A LF	0B .		
9	E9	C9	29 )	0F SI	0C FF	3F ?	0D CR	0A LF		
	F9	D9	39 9	0F SI	0C FF	2F /	0D CR	0A LF		
	E9	C9	29 )	4F O	4C L	3F ?	0D CR	0A .		
	F9	D9	39 9	6F o	6C l	2F /	0D CR	0A .		
A	EA	CA	37 7	34 4	31 1	30 0	A0	A6		
	FA	DA	37 7	34 4	31 1	30 0	B0	B6		
	EA	CA	37 7	34 4	31 1	30 0	A0	A6		
	FA	DA	37 7	34 4	31 1	30 0	B0	B6		
B	EB	CB	38 8	35 5	32 2	2E .	A1	A7		
	FB	DB	38 8	35 5	32 2	2E .	B1	B7		
	EB	CB	38 8	35 5	32 2	2E .	A1	A7		
	FB	DB	38 8	35 5	32 2	2E .	B1	B7		
C	EC	CC	39 9	36 6	33 3	BF	A2	A8		
	FC	DC	39 9	36 6	33 3	AF	B2	B8		
	EC	CC	39 9	36 6	33 3	9F	A2	A8		
	FC	DC	39 9	36 6	33 3	8F	B2	B8		
D	ED	CD	90	93	82	95	A3	A9		
	FD	DD	90	93	82	95	B3	B9		
	ED	CD	90	93	82 .	95	A3 .	A9 .		
	FD	DD	90	93	82 .	95	B3 .	B9 .		
E	EE	CE	91	80	84	81	A4	AA		
	FE	DE	91	80	84	81	B4	BA		
	EE	CE	91	80 .	84	81 .	A4 .	AA .		
	FE	DE	91	80 .	84	81 .	B4 .	BA .		
F	EF	CF	92	94	83	96	A5	AB		
	FF	DF	92	94	83	96	B5	BB		
	EF	CF	92	94	83 .	96	A5 .	AB .		
	FF	DF	92	94	83 .	96	B5 .	BB .		

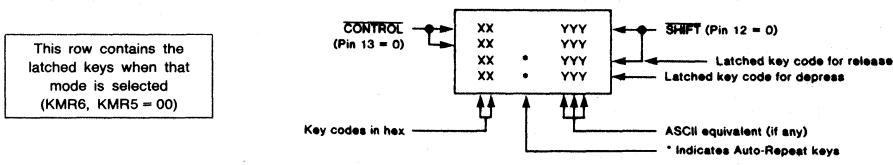

T8002905



# Programmable Keyboard and Communication Controller (PKCC)

SCN2671

2

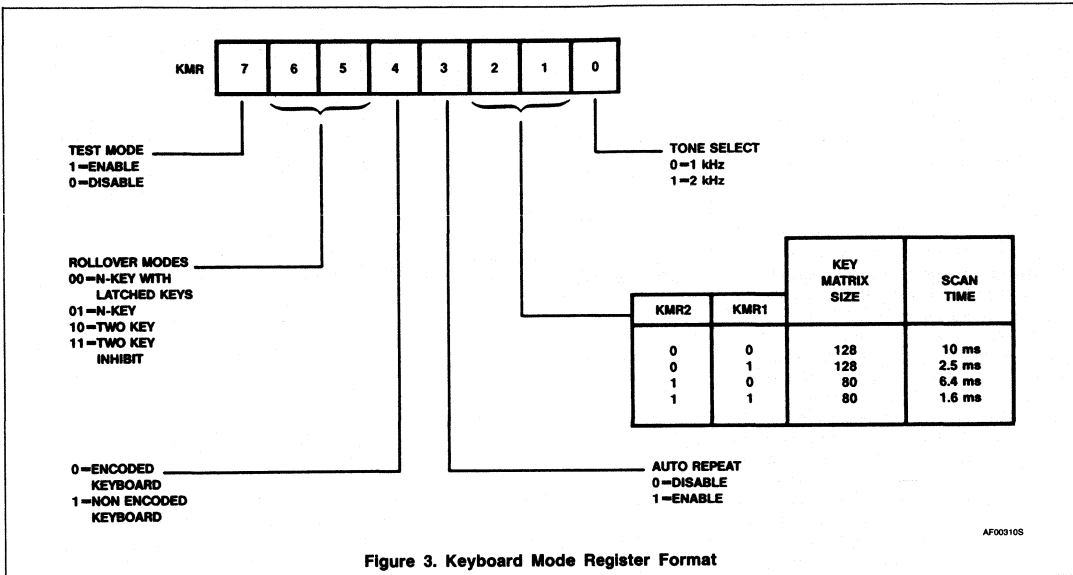

Figure 3. Keyboard Mode Register Format

Bit KMR3 enables the auto-repeat mode. In this mode, if a key that is programmed for auto-repeat is depressed for longer than one-half second, the key code will be loaded into the KDR approximately 15 times per second until that key is released. Only the non-control key codes will auto-repeat, i.e. CONTROL = 1. Table 2 specifies the auto-repeat keys.

KMR2 and KMR1 select the key matrix size and debounce time (scan rate). The keyboard row outputs (KR2, KR1, KR0) always scan from 0 to 7. The column outputs (KC3, KC2, KC1, KC0) scan from 0 to 15 for a 128 key matrix and from 0 to 9 for an 80 key matrix.

KMR0 selects between a 1kHz and 2kHz frequency to be output on the TONE pin in response to a ring tone command.

### Keyboard Status Register

The keyboard status register (KSR) provides operational feedback to the CPU. Its format is illustrated in Figure 4.

KSR7, 6 and 4 reflect the state of the inputs at the corresponding pins. CONTROL and SHIFT are latched at the time the key is accepted. As the verified codes are loaded into the KDR, the corresponding states of CONTROL and SHIFT are loaded into the KSR. REPEAT is updated on every matrix sample. The status bits are the complements of the input levels.

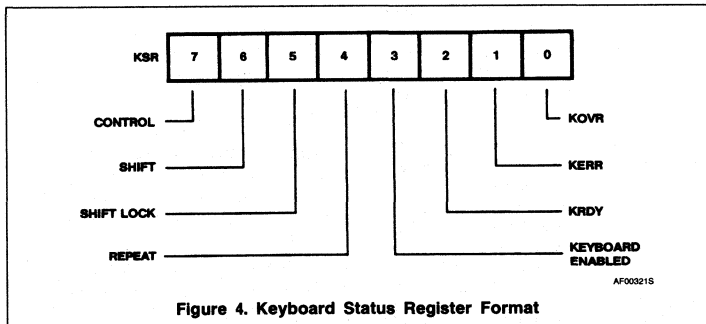

Figure 4. Keyboard Status Register Format

KSR5 reflects the state of the internal shift lock flag which is controlled by the set/reset shift lock commands.

KSR3 indicates that the keyboard controller is enabled. It is controlled by the set/clear keyboard enable command.

Keyboard overrun (KSR2) is set when both the KHR and KDR are full and a third key is validated. The original content of the KHR is preserved and the content of the KDR is overwritten with the new key code. This bit can be specified (by IMR1) to generate an interrupt and is cleared by the reset command with D2 = 1.

Keyboard error (KSR1) is set when the operator depresses more keys than are allowed in the selected rollover mode, or when keys are depressed simultaneously (within one scan cycle). This bit can be specified (by IMR3) to generate an interrupt and is cleared by the reset command with D1 = 1.

Keyboard data ready (KSR0) is set when the key code or address is transferred from the KDR to the KHR. This bit can be specified (by IMR2) to generate an interrupt. It is cleared when the CPU reads the KHR.

# Programmable Keyboard and Communication Controller (PKCC)

SCN2671

## Communications Controller

The communications controller section of the PKCC comprises a full duplex asynchronous receiver/transmitter (UART) with a baud rate generator. Registers associated with these elements are the communications mode register (CMR), the baud rate control register (BRR), and the communications status register (CSR).

### Receiver

The receiver accepts serial data on the RxD pin, converts the serial input to parallel format, checks for start bit, stop bit, parity bit (if any), or break condition, and presents the assembled character to the CPU. The receiver looks for a high to low (mark to space) transition of the start bit on the RxD input pin. If a transition is detected, the state of the RxD pin is sampled again after a delay of one half of the bit time. If RxD is then high, the start bit is invalid and the search for a valid start bit begins again. If RxD is still low, a valid start bit is assumed and the receiver continues to sample the input at one bit time intervals at the theoretical center of the bit, until the proper number of data bits and the parity bit (if any) have been assembled, and one stop bit has been detected. The least significant bit is received first. The data is then transferred to the receive holding register (RxHR) and the RxRDY bit in the CSR is set to a 1. If the character length is less than eight bits, the most significant unused bits in the RxHR are set to zero.

After the stop bit is detected, the receiver will immediately look for the next start bit. However, if a non-zero character was received without a stop bit (i.e. framing error) and RxD remains low for one half of the bit period after the stop bit was sampled, then the space is interpreted as a start bit.

The parity error, framing error and overrun error (if any) are strobed into the CSR at the received character boundary. If a break condition is detected (RxD is low for the entire character including the stop bit) only one character consisting of all zeros will be transferred to the RxHR and the received break bit in the CSR is set to 1 (RxRDY is not set when a break is received). The RxD input must return to a high condition for one bit time before a search for the next start bit begins.

### Transmitter

The transmitter accepts parallel data from the CPU and converts it to a serial bit stream on the TxD output pin. It automatically sends a start bit followed by the data bits, an optional parity bit, and the programmed number of stop bits. The least significant bit is sent first. Following the transmission of the stop bits, if

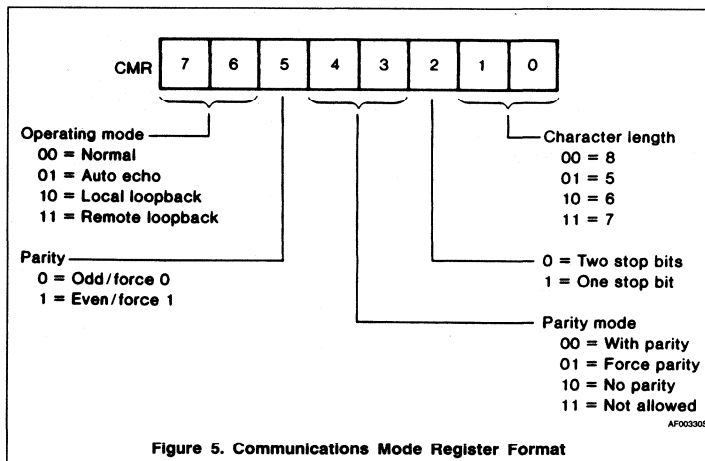

a new character is not available in the transmit holding register (TxHR), the TxD output remains high and the TxEMT bit in the CSR will be set to 1. Transmission resumes and the TxEMT bit is cleared when the CPU loads a new character into the TxHR. The transmitter can be forced to send a continuous low condition by a transmit break command.

If the transmitter is disabled, it continues operating until the character currently being transmitted is completely sent out.

### Communication Mode Register

Figure 5 illustrates the bit format of the CMR, which controls the operational mode of the communications controller and the character parameters.

Bits CMR1 – CMR0 select a character length of 5, 6, 7, or 8 bits. The character length does not include the parity, start, or stop bits.

CMR2 selects the transmitted character framing as one or two stop bits. The receiver always checks for one stop bit.

The parity format is selected by bits CMR4 and CMR3. If parity or force parity is selected, a parity bit is added to the transmitted character and the receiver performs a parity check on incoming data. CMR5 selects odd or even parity and determines the polarity of the parity bit in the force parity mode.

The bits in the mode register affecting character assembly and disassembly (CMR5 – CMR0) can be changed dynamically and affect the characters currently being assembled in RxSR and transmitted by TxSR. To affect assembly of a received character, the CMR must be updated within n–1 bit times

of the receipt of that character's start bit. To affect a transmitted character, the CMR must be updated within n–1 bit times of transmitting that character's start bit. (n = the smaller of the new and old character lengths).

The UART can operate in one of four modes, as illustrated in Figure 6. The operating modes are selected by bits CMR7 and CMR6, which should only be changed when both the transmitter and receiver are disabled. CMR7-CMR6 = 00 is the normal mode, with the transmitter and receiver operating independently. CMR7-CMR6 = 01 places the UART in the automatic echo mode, which automatically retransmits the received data. The following conditions are true while in automatic echo mode:

1. Data assembled by the receiver is automatically placed in the transmit holding register and retransmitted on the TxD output.
2. The receive clock is used for the transmitter.
3. The receiver must be enabled, but the transmitter need not be enabled.
4. Status bit TxRDY is not set. TxEMT operates normally.
5. The receiver parity is checked, but is not regenerated for transmission, i.e., transmitted parity bit is as received.
6. Only the first character of a break condition is echoed; the TxD output will go high until the next received character is assembled.
7. CPU to receiver communication continues normally, but the CPU to transmitter link is disabled.

# Programmable Keyboard and Communication Controller (PKCC)

SCN2671

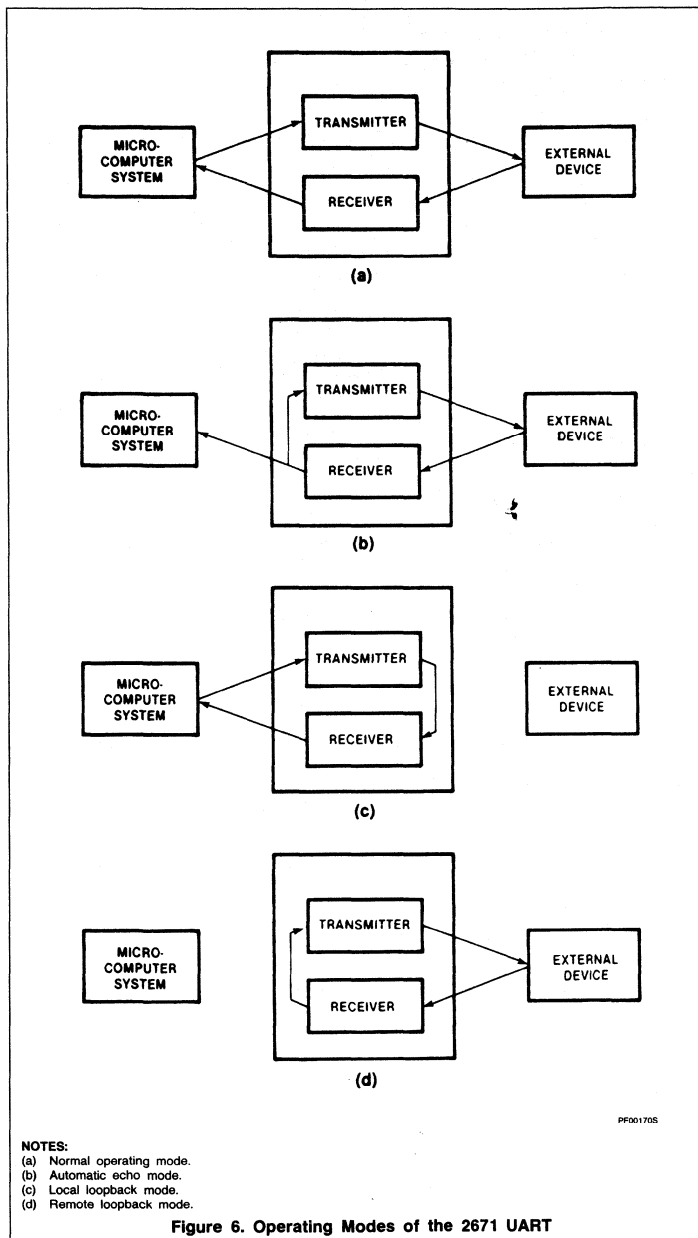

Figure 6. Operating Modes of the 2671 UART

Two diagnostic modes can also be configured. In local loopback mode (CMR7 - CMR6 = 10):

1. The transmitter output is internally connected to the receiver input.
2. The transmit clock is used for the receiver.
3. The TxD output is held high.
4. The RxD input is ignored.
5. The transmitter must be enabled, but the receiver need not be enabled.
6. CPU to transmitter and receiver communications continue normally.

The second diagnostic mode is the remote loopback mode (CMR7 - CMR6 = 11). In this mode:

1. Data assembled by the receiver is automatically placed in the transmit holding register and retransmitted on the TxD output.
2. The receive clock is used for the transmitter.
3. No data is sent to the local CPU, but the error status conditions (parity and framing) are set if required.
4. The received parity is checked, but is not regenerated for transmission, i.e., transmitted parity bit is as received.
5. The receiver must be enabled, but the transmitter need not be enabled.

### Baud Rate Control Register

The baud rate control register (BRR) controls the frequency generated by the baud rate generator (BRG) and the clock source used by the receiver and transmitter. Its format is illustrated in Figure 7.

BRR3 - BRR0 select one of sixteen frequencies to be generated by the BRG. See Table 3.

BRR7 and BRR6 select the source of the transmit and receive clocks. If external clocks are chosen, (BRR7 = 0 or BRR6 = 0), then the clock rate factor is determined by BRR5 and BRR4. The external clock input(s) should be the desired baud rate multiplied by the clock rate factor.

If internal clock(s) are specified, (BRR7 = 1 or BRR6 = 1), the clock is supplied by the internal baud rate generator at the selected baud rate. The clock rate factor for internally generated clocks is always 16. Pins 35 and 34 become outputs for transmit or receive clocks, respectively. See Table 4 for the description and selection of these outputs.

# Programmable Keyboard and Communication Controller (PKCC)

SCN2671

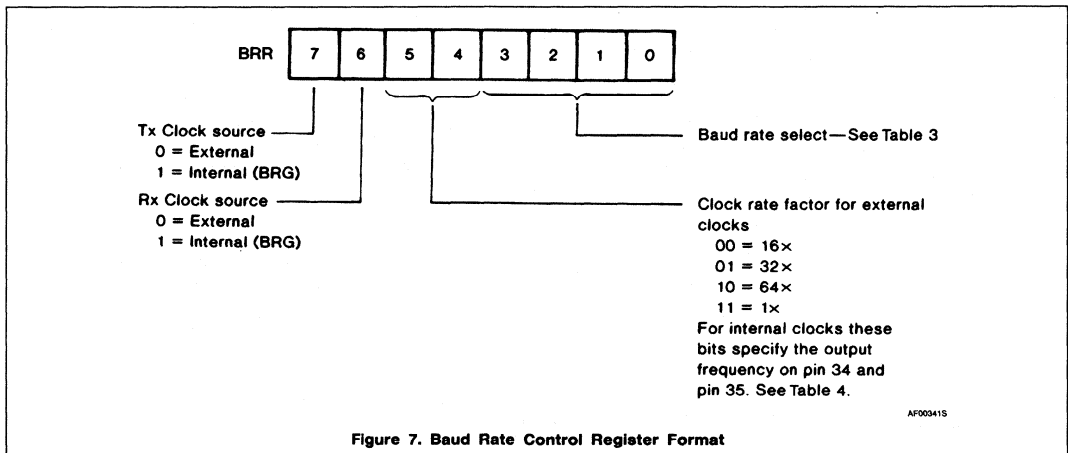

Figure 7. Baud Rate Control Register Format

Table 3. Baud Rate Generator Characteristics (BRCLK = 4.9152MHz)

BRR3-0	BAUD RATE	ACTUAL FREQUENCY 16X CLOCK	PERCENT ERROR	DIVISOR
0000	50	0.8 kHz	-	6144
0001	110	1.7598	-0.01	2793
0010	134.5	2.152	-	2284
0011	150	2.4	-	2048
0100	200	3.2	-	1536
0101	300	4.8	-	1024
0110	600	9.6	-	512
0111	1050	16.8329	+0.20	292
1000	1200	19.2	-	256
1001	1800	28.7438	-0.20	171
1010	2000	31.9168	-0.26	154
1011	2400	38.4	-	128
1100	4800	76.8	-	64
1101	9600	153.6	-	32
1110	19200	307.2	-	16
1111	38400	614.4	-	8

# Programmable Keyboard and Communication Controller (PKCC)

SCN2671

Table 4. Baud Rate Control Register

BRR7 - BRR4	CLOCK SOURCE		PIN FUNCTIONS		BRR3 - BRR0 BAUD RATE SELECTION
	TxC	RxC	PIN 34	PIN 35	
00**	E	E	TxC	RxC	The baud rates are listed in Table 3.
01**	E	I	TxC	1X	
10**	I	E	16X	RxC	
1100	I	I	1X	1X	
1101	I	I	1X	16X	
1110	I	I	16X	1X	
1111	I	I	16X	16X	

## NOTES:

- \*\* = Clock rate factor for external clocks: 00 = 16X  
01 = 32X  
10 = 64X  
11 = 1X

2. E = External clock.

3. I = Internal clock (BRG).

4. 1X and 16X are clock outputs at 1 or 16 times the actual baud rate. For receive, the 1X output is the actual data sample clock.

5. BRR7 - BRR6 = 01 or 10 not permitted in automatic echo or remote loopback modes unless BRR5 - BRR4 = 00.

## Communications Status Register

Figure 8 illustrates the bit format of the communications status register (CSR), which provides UART status to the CPU.

Receiver ready (CSR0) indicates that a received character is assembled and transferred to the RxHR and is ready to be read by the CPU. This bit can be specified (by IMR0) to generate an interrupt and is reset by receiving the RxHR.

Transmitter ready (CSR1) indicates that the TxHR is empty and ready to be loaded with a character. This bit will be cleared when the TxHR is loaded and has not yet transferred the character to the transmit shift register (TxSR). TxRDY is reset when the transmitter is disabled. It will be set when the transmitter is enabled, provided that no data was loaded into the TxHR during the time the transmitter was disabled. This bit can be specified (by IMR7) to generate an interrupt.

Transmitter empty (CSR2) indicates that the transmitter has underrun, i.e., both the TxHR and TxSR are empty. This bit can only be set after transmission of at least one character, and is cleared when the TxHR is loaded by the CPU. TxEMT is reset when the transmitter is disabled. This bit can be specified (by IMR6) to generate an interrupt.

CSR3 will be set when the PKCC receives a command to transmit a break. This bit will be cleared after the break is completed.

Received break (CSR4) indicates that an all zero character of the programmed length has been received without a stop bit. Breaks originating in the middle of a received character can be detected. This bit is cleared when

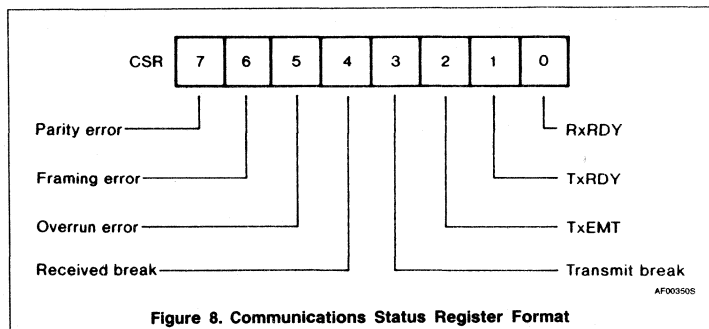

Figure 8. Communications Status Register Format

RxD returns to a high state for at least one bit time.

Receiver overrun (CSR5) indicates that the previous character in the RxHR has not been read by the CPU and that a new character has been loaded into the RxHR. This bit is cleared by a reset command with D3 = 1.

Framing error (CSR6) indicates that the stop bit has not been detected. The stop bit check is made in the middle of the first stop bit position. This bit is cleared by a reset command with D3 = 1.

Parity error (CSR7) indicates that a character was received with incorrect parity when 'with parity' or 'force parity' is enabled. This bit is cleared by a reset command with D3 = 1.

## Interrupt Controller

The SCN2671 contains a maskable interrupt status register (ISR) which can be enabled to generate an active low interrupt request on the  $\overline{\text{INTR}}$  output. The eight interrupt condi-

tions in the ISR are individually enabled by writing a 1 into the corresponding bit of the interrupt mask register (IMR).

Each of the interrupt conditions is assigned a priority and a vector. When an enabled ISR bit is set, the SCN2671 asserts the  $\overline{\text{INTR}}$  output. If the CPU activates the  $\overline{\text{INTA}}$  input, the SCN2671 responds by placing the corresponding 8-bit vector on the data bus (D7 - D0). If multiple interrupts are pending, the vector corresponds to the condition with the highest priority. The interrupt will persist until all pending interrupt conditions are cleared.

The ISR can also be polled by reading at address A2 - A0 = 000. All pending interrupt conditions which are enabled by the IMR will be read independent of priority.

The bit assignments of the ISR and IMR and corresponding vectors and priorities are listed in Table 5.

# Programmable Keyboard and Communication Controller (PKCC)

SCN2671

Table 5. Interrupt Mask Register (IMR) and Interrupt Status Register (ISR)

BIT IN IMR/ISR	INTERRUPT CONDITION	PRIORITY	VECTOR ON D7 - D0		CONDITION RESET BY:
			BINARY	HEX	
IMR0/ISR0	RxRDY	1	11001111	CF	Read RxHR
IMR1/ISR1	KOVR	2	11010111	D7	Reset CMD (D2 = 1)
IMR2/ISR2	KRDY	3	11011111	DF	Read KHR
IMR3/ISR3	KERR	4	11100111	E7	Reset CMD (D1 = 1)
IMR4/ISR4	XINT <sup>1</sup>	5	11101111	EF	External
IMR5/ISR5	ΔBREAK <sup>2</sup>	6	11110111	F7	Reset CMD (D4 = 1)
IMR6/ISR6	TxE <sub>MT</sub>	7	11000111	C7	Load TxHR
IMR7/ISR7	TxRDY	8	11000111	C7	Load TxHR

**NOTES:**

- XINT is an input from an external interrupt source, active low (pin 21).
- ΔBREAK refers to the change of a received break condition.

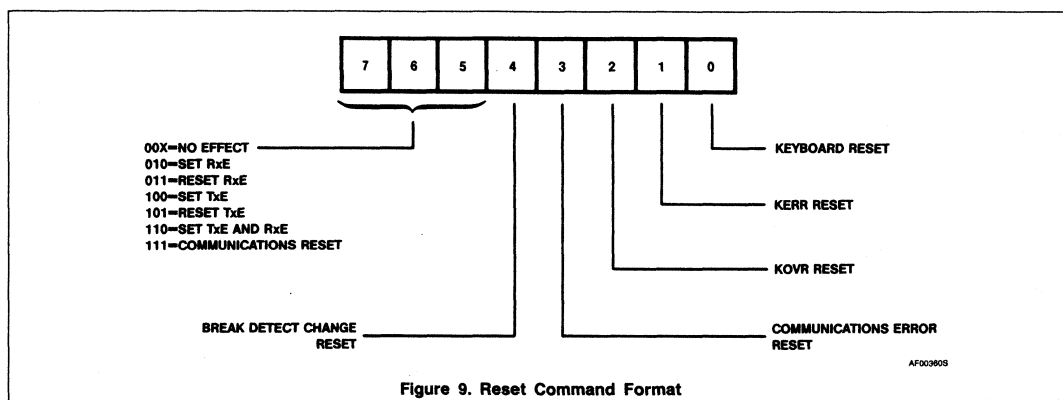
**COMMANDS**

In addition to the control exercised by programming of the PKCC control registers, several functions can be performed by executing command operations. There are two classes of commands which are initiated by writing to the SCN2671 at address A2 - A0 = 000 (reset command) and address A2 - A0 = 111 (miscellaneous commands). Individual commands are specified by the bit pattern on the data bus (D7 - D0).

**Reset Commands**

The reset command bit format is illustrated in Figure 9 and the detail command descriptions are given in Table 6.

A reset command with D7 - D0 = 111XXXX1 is a master reset for the SCN2671. This command must be given following a power on condition to release the internal power on reset latch which deactivates the SCN2671 on power-up.

**Miscellaneous Commands**

The miscellaneous command format is illustrated in Figure 10.

The transmit break commands force a break (steady low output) on the Tx<sub>D</sub> pin immediately or after the character in the Tx<sub>SR</sub> (if any) is transmitted. A timed break lasts for approximately 200ms, and a character break lasts for one character time including parity and stop bit time. In either case, Tx<sub>RDY</sub>

(CSR1) will be set at the beginning of the break which can be extended indefinitely (by 200ms or one character time increments) by reasserting the command in response to Tx<sub>RDY</sub>. Note that these commands reset Tx<sub>RDY</sub>. When a transmit break command is asserted, CSR3 will be set. The bit will be cleared after the break is completed.

The ring tone commands cause the tone generator to output a square wave on the TONE output. The tone durations are specified by the commands:

- Ring tone short = 25ms
- Ring tone long = 100ms

The tone frequency is either 1kHz or 2kHz, as specified by KMR0.

# Programmable Keyboard and Communication Controller (PKCC)

SCN2671

Table 6. Reset Command Description

COMMAND	RESETS	COMMENTS
Keyboard reset	KMR7 - KMR0 KSR5, KSR3 - KSR0 IMR3 - IMR1	The keyboard controller is reset, ignoring the input at KRET.
KERR reset	KSR1	Keyboard error status bit reset.
KOVR reset	KSR2	Keyboard overrun status bit reset.
Communications error reset	CSR7 - CSR5	Resets the receiver overrun, parity, and framing error status bits.
Break detect change reset	ISR5	Resets the break detect change bit in the interrupt status register.
Set RxE	See note	Enables receiver operation.
Reset RxE	CSR7 - CSR4, CSR0 See note	Disables the receiver.
Set TxE	See note	Enables transmitter operation.
Reset TxE	CSR3 - CSR1 See note	Disables the transmitter. Sets the TxD output to a 1 after transmitting the character in TxSR.
Communications reset	CMR, CSR, BRR, TxE, RxE, IMR7 - IMR5, IMR0	Resets the communication controller. The RxD input is ignored and the TxD output is set to a 1.
Master reset	CMR, CSR, BRR, TxE, RxE, KMR, KSR5, KSR3 - KSR0, IMR7 - IMR0 Releases the internally latched power on reset.	Resets the keyboard and communication controllers. Inputs at KRET and RxD are ignored and the TxD output is set to a 1.

**NOTE:**

Command does not affect the CMR or the BRR.

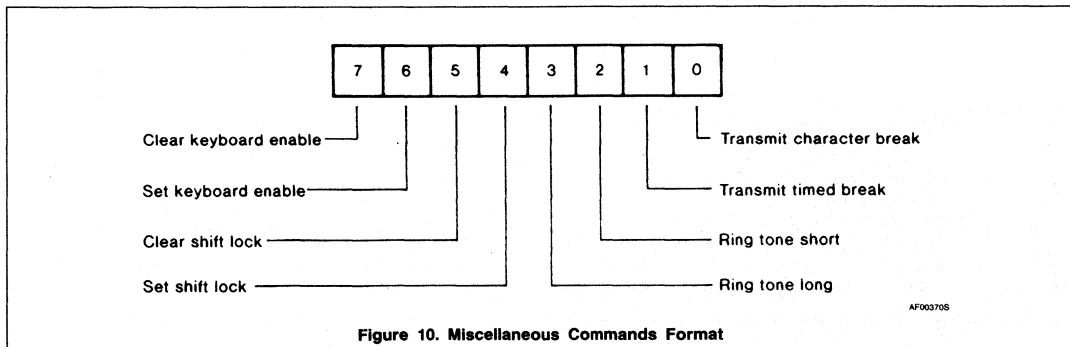

Figure 10. Miscellaneous Commands Format

The set/clear shift lock commands control the state of the internal shift lock flip-flop. When shift lock is set, the keyboard controller encodes all key depressions as if the SHIFT input was asserted. The state of the shift lock flip-flop is reflected in KSR5.

The set keyboard enable command enables the keyboard controller and sets KSR3 in the keyboard status register. The clear keyboard enable command resets KSR3 and disables key processing at the KRET input. The keyboard controller is not reset by this command, and the current state of the keyboard (key

depressions and latched key states) is preserved internally. When the keyboard is subsequently enabled, key processing resumes, old and new keys are debounced, and latched keys are encoded if there has been a change in their state.

### MASK-PROGRAMMABLE OPTIONS

Characteristics of certain portions of the PKCC are internally programmed by means of

a read only memory. The items which can be programmed are:

- Key codes
- Auto-repeat keys
- Scan times, tone frequency, and tone duration
- Baud rates
- Interrupt vectors

Consult your local Signetics representative for costs, minimum quantities, and data submission requirements for customized versions of the PKCC.

# Programmable Keyboard and Communication Controller (PKCC)

SCN2671

## ABSOLUTE MAXIMUM RATINGS

SYMBOL	PARAMETER	RATING	UNIT
T <sub>A</sub>	Operating ambient temperature <sup>2</sup>	0 to +70	°C
T <sub>STG</sub>	Storage temperature range	-65 to +150	°C
	All voltages with respect to ground <sup>3</sup>	-0.5 to +6.0	V

## DC ELECTRICAL CHARACTERISTICS T<sub>A</sub> = 0°C to +70°C, V<sub>CC</sub> = +5V ± 5%<sup>4, 5, 6</sup>

SYMBOL	PARAMETER	TEST CONDITIONS	LIMITS			UNIT
			Min	Typ	Max	
V <sub>IL</sub> V <sub>IH</sub>	Input low voltage Input high voltage XTAL1, XTAL2/BRCLK All other inputs		4 2		0.8	V V V
V <sub>OL</sub> V <sub>OH</sub>	Output low voltage Output high voltage (except $\overline{\text{INTR}}$ )	I <sub>OL</sub> = 1.6mA I <sub>OH</sub> = -100μA	2.4		0.4	V V
I <sub>IL</sub> I <sub>XTLIL</sub> I <sub>XTLIH</sub>	Input leakage current (except XTAL1, XTAL2/BRCLK) Input low current XTAL1 XTAL2/BRCLK <sup>7</sup> Input high current XTAL1 XTAL2/BRCLK <sup>7</sup>	V <sub>IN</sub> = 0 to V <sub>CC</sub>  V <sub>IN</sub> = 0  V <sub>IN</sub> = V <sub>CC</sub>	-10  -80 -4	  -30 -1.5	10	μA μA mA μA mA
I <sub>LL</sub> I <sub>CC</sub>	Data bus 3-State leakage current Power supply current	V <sub>O</sub> = 0 to V <sub>CC</sub>	-10		10 150	μA mA

## AC ELECTRICAL CHARACTERISTICS T<sub>A</sub> = 0°C to +70°C, V<sub>CC</sub> = +5V ± 5%<sup>4, 5, 6</sup>

SYMBOL	PARAMETER	TEST CONDITIONS	LIMITS			UNIT
			Min	Typ	Max	
<b>Read timing (see Figure 11)</b>						
t <sub>AS</sub>	Address setup to $\overline{\text{RD}}$		50			ns
t <sub>CS</sub>	CE setup to $\overline{\text{RD}}$		50			ns
t <sub>pw</sub>	$\overline{\text{RD}}$ pulse width		250			ns
t <sub>AH</sub>	Address hold from $\overline{\text{RD}}$		20			ns
t <sub>CH</sub>	CE hold from $\overline{\text{RD}}$	C <sub>L</sub> = 150pF	0			ns
t <sub>DD</sub>	Data delay for read				200	ns
t <sub>DF</sub>	Data bus floating time for read	C <sub>L</sub> = 150pF	10		100	ns
t <sub>AD1</sub>	Access delay from any read to next read or write		250			ns
<b>Write timing (see Figure 12)</b>						
t <sub>AS</sub>	Address setup to $\overline{\text{WR}}$		50			ns
t <sub>CS</sub>	CE setup to $\overline{\text{WR}}$		50			ns
t <sub>pw</sub>	$\overline{\text{WR}}$ pulse width		250			ns
t <sub>AH</sub>	Address hold from $\overline{\text{WR}}$		20			ns
t <sub>CH</sub>	CE hold from $\overline{\text{WR}}$		0			ns
t <sub>DS</sub>	Data setup		100			ns
t <sub>DH</sub>	Data hold		10			ns
t <sub>AD2</sub>	Access delay from any write to next read or write		250			ns
	Access delay from reset command to next read or write		1			μs



# Programmable Keyboard and Communication Controller (PKCC)

SCN2671

## AC ELECTRICAL CHARACTERISTICS (Continued)

SYMBOL	PARAMETER	TEST CONDITIONS	LIMITS			UNIT
			Min	Typ	Max	
<b>Interrupt acknowledge timing (see Figure 13)</b>						
t <sub>PWI</sub>	INTA pulse width		300			ns
t <sub>DDI</sub>	Data delay time for interrupt vector	C <sub>L</sub> = 150pF			250	ns
t <sub>DFI</sub>	Data bus floating time after INTA	C <sub>L</sub> = 150pF	10		100	ns
t <sub>ADI</sub>	INTA to INTA access delay		300			ns
<b>INTR reset timing (see Figure 14)</b>						
t <sub>RI</sub>	INTR delay from: Read RxHR (RxRDY) Read KHR (KRDY) Reset commands (KOV, KERR, BREAK) Load TxHR (TxEMT, TxRDY) Mask bit reset				400 400 450 400 300	ns ns ns ns ns
<b>Keyboard timing (see Figures 15 and 16)</b>						
f <sub>KCLK</sub>	KCLK frequency			409		kHz
t <sub>KBD</sub>	KR <sub>i</sub> ,KC <sub>i</sub> to KRET sample delay: FAST SCAN SLOW SCAN		12 55			μs μs
t <sub>POS</sub>	Scan time per matrix position: FAST SCAN SLOW SCAN			20 80		μs μs
t <sub>KRD</sub>	KDRES delay from KCLK	C <sub>L</sub> = 150pF			400	ns
t <sub>KRH</sub>	KDRES hold from KCLK	C <sub>L</sub> = 150pF			400	ns
t <sub>HYS</sub>	HYS delay from KCLK	C <sub>L</sub> = 150pF			600	ns
t <sub>RCD</sub>	KR <sub>i</sub> ,KC <sub>i</sub> delay from KCLK	C <sub>L</sub> = 150pF			400	ns
<b>UART timing (see Figures 17, 18, 19)</b>						
t <sub>RXS</sub>	RxD setup time		200			ns
t <sub>RxH</sub>	RxD hold time		200			ns
t <sub>TxD</sub>	TxD delay from falling edge of TxC	C <sub>L</sub> = 150pF			300	ns
t <sub>TCS</sub>	Skew between TxD transition and falling edge of TxC output	C <sub>L</sub> = 150pF		0		ns
t <sub>BRH</sub>	XTAL1 clock high <sup>8</sup>		70			ns
t <sub>BRL</sub>	XTAL1 clock low <sup>8</sup>		70			ns
f <sub>BRG</sub>	BRG input frequency		1	4.9152	5.075	MHz
f <sub>R/T</sub>	TxC or RxC input frequency	Clock rate factor = 16×, 32×, 64× Clock rate factor = 1×			1.3	MHz
t <sub>R/TH</sub>	TxC or RxC clock high		350		1	ns
t <sub>R/TL</sub>	TxC or RxC clock low		350			ns

**NOTES:**

- Stresses above those listed under Absolute Maximum Ratings may cause permanent damage to the device. This is stress rating only and functional operation of the device at these or at any other condition above those indicated in the operation section of this specification is not implied.
- For operating on elevated temperatures, the device must be operated based on +150°C maximum function temperature.
- This product includes circuitry specifically designed for the protection of its internal devices from damaging effects of excessive static charge. Nonetheless, it is suggested that conventional precautions be taken to avoid applying any voltages larger than the rated maxima.
- Parameters are valid over operating temperature range unless otherwise specified.
- All voltage measurements are referenced to ground (V<sub>SS</sub>). All input signals swing between 0.4V and 2.4V with a transition time of 20ns maximum and time measurements are referenced at input voltages of 0.8V, 2V and at output voltages of 0.8V, 2V as appropriate, unless otherwise specified.
- Typical values are at +25°C, typical supply voltages and typical processing parameters.
- XTAL2 input currents are measured with XTAL grounded.
- See Figures 20 and 21 for XTAL1, WTAL2 connections for driving XTAL2 with an external clock. Input levels for XTAL1 and XTAL2 are V<sub>IL</sub> ≤ 0.8V, V<sub>IH</sub> ≥ 4.0V, and t<sub>BRL</sub> and t<sub>BRH</sub> are measured at these levels.

Programmable Keyboard and  
Communication Controller (PKCC)

SCN2671

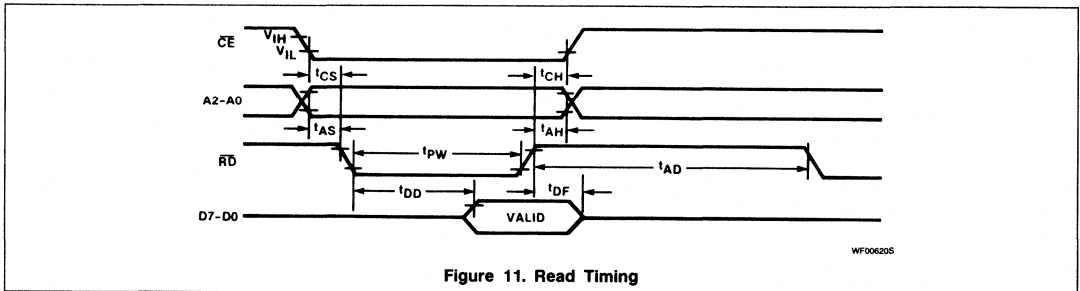

Figure 11. Read Timing

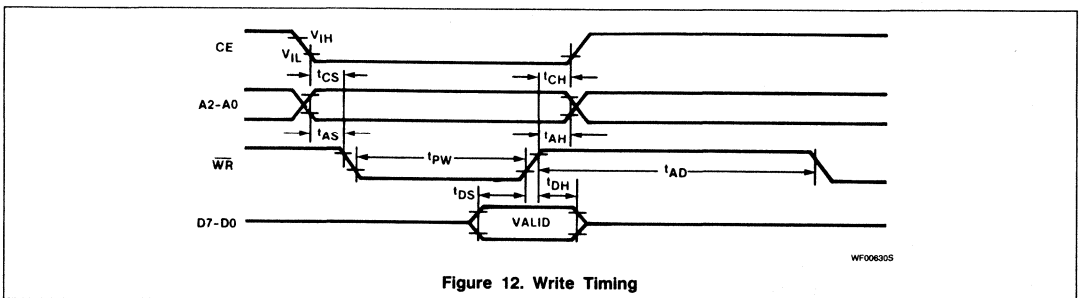

Figure 12. Write Timing

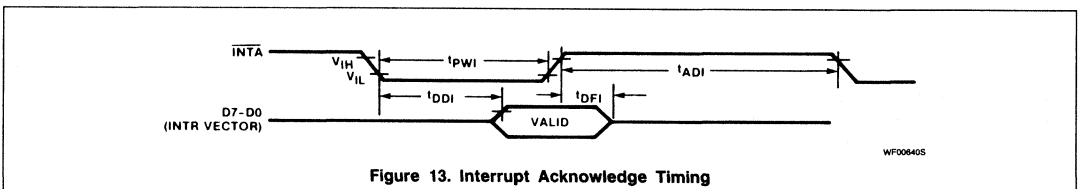

Figure 13. Interrupt Acknowledge Timing

# Programmable Keyboard and Communication Controller (PKCC)

## SCN2671

2

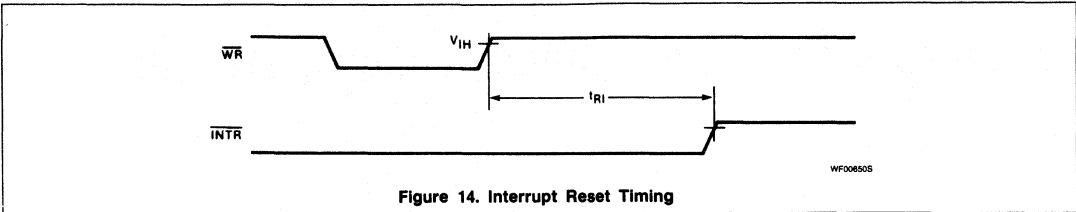
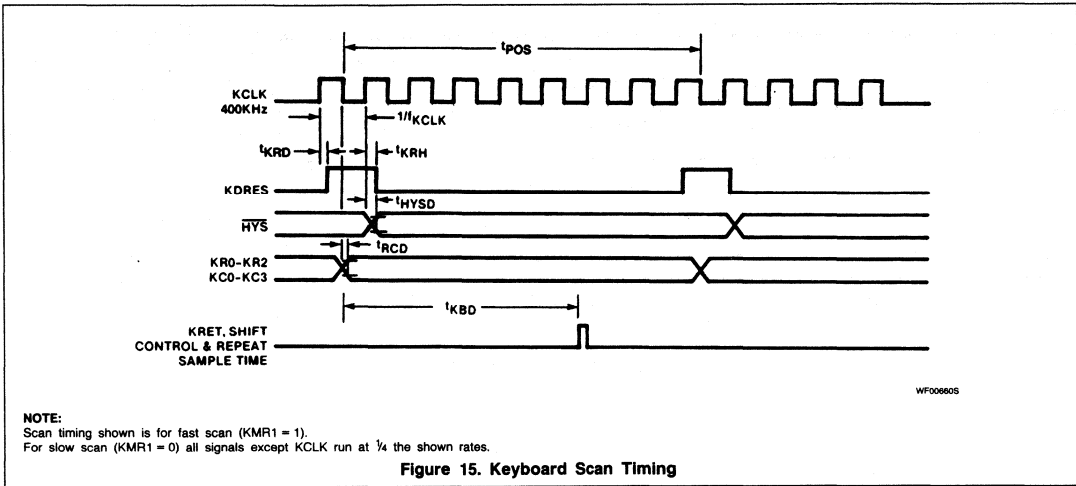

Figure 14. Interrupt Reset Timing



**NOTE:**  
 Scan timing shown is for fast scan (KMR1 = 1).  
 For slow scan (KMR1 = 0) all signals except KCLK run at 1/4 the shown rates.

Figure 15. Keyboard Scan Timing

Programmable Keyboard and  
Communication Controller (PKCC)

SCN2671

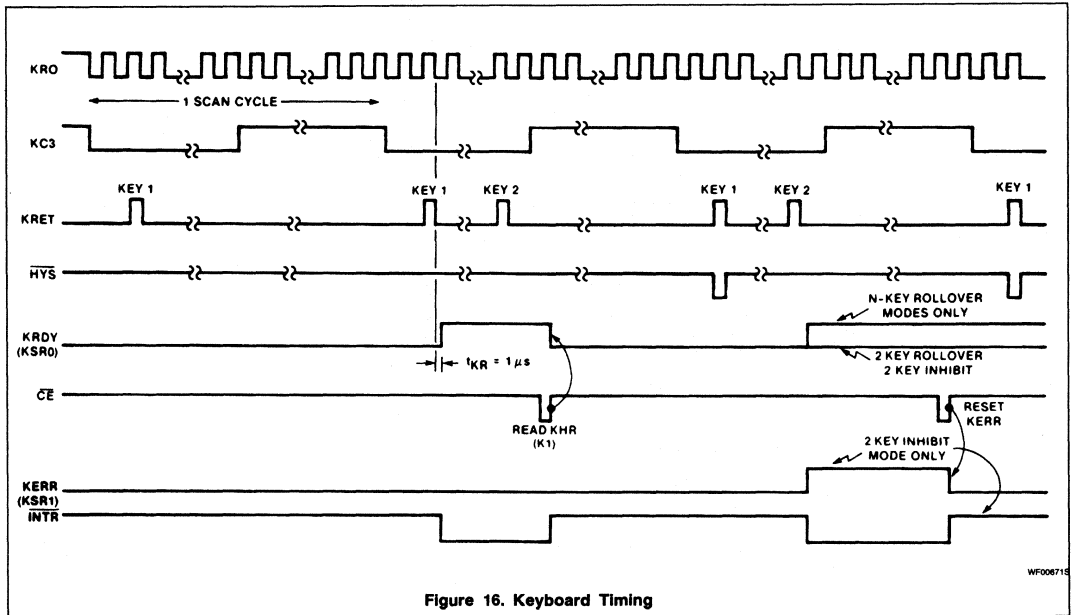
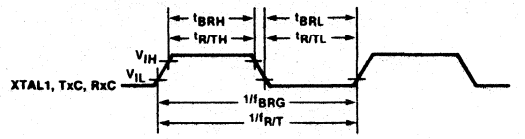

Figure 16. Keyboard Timing

Programmable Keyboard and  
Communication Controller (PKCC)

SCN2671

2



WF006805

**Clock**

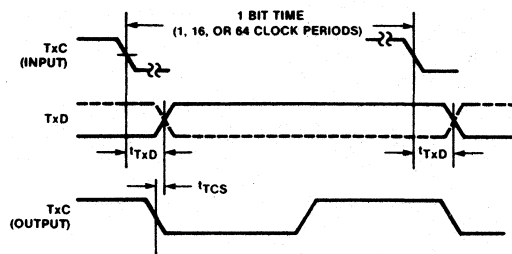

WF006805

**Transmit**

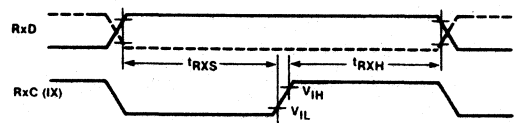

WF007005

**Receive**

**Figure 17**

# Programmable Keyboard and Communication Controller (PKCC)

SCN2671

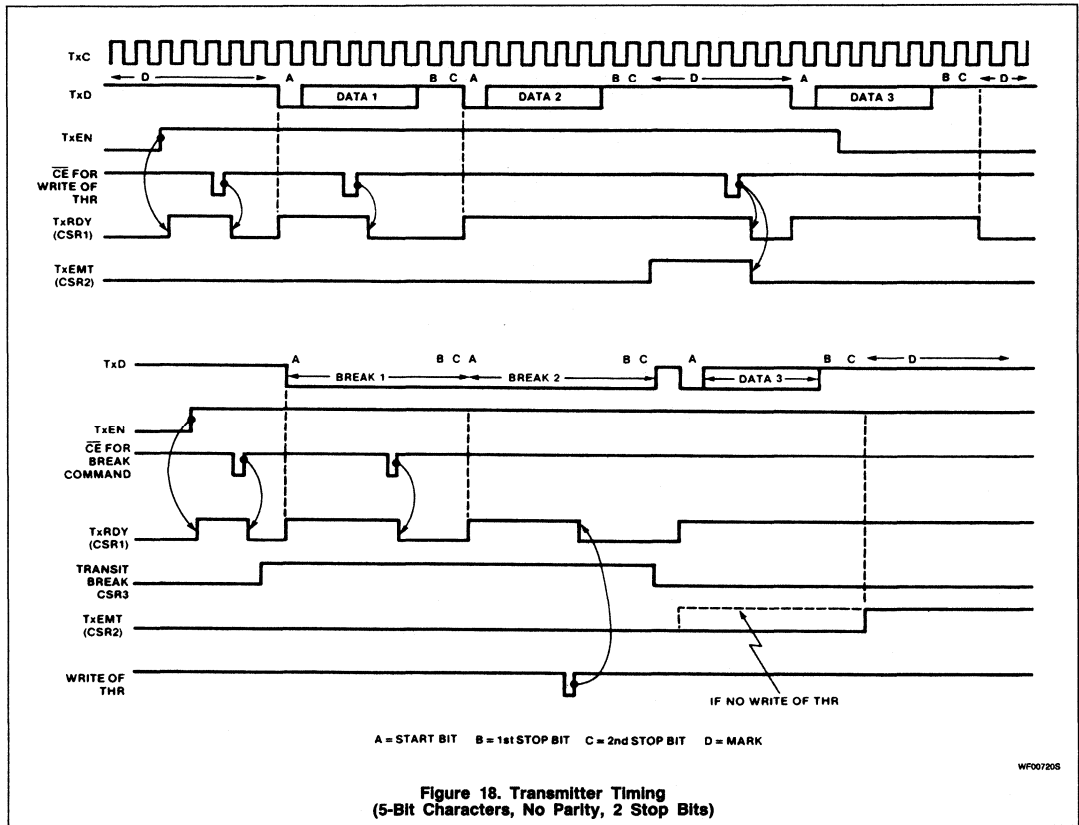

# Programmable Keyboard and Communication Controller (PKCC)

SCN2671

2

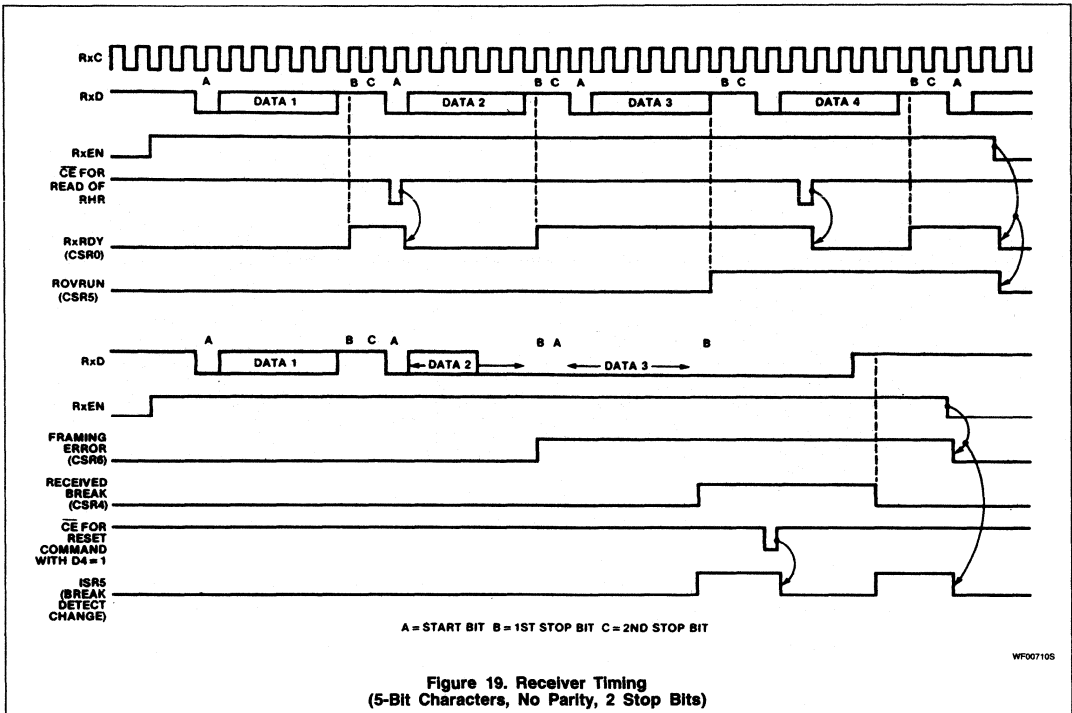

Figure 19. Receiver Timing (5-Bit Characters, No Parity, 2 Stop Bits)

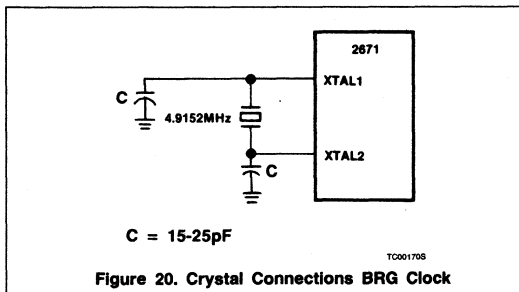

Figure 20. Crystal Connections BRG Clock

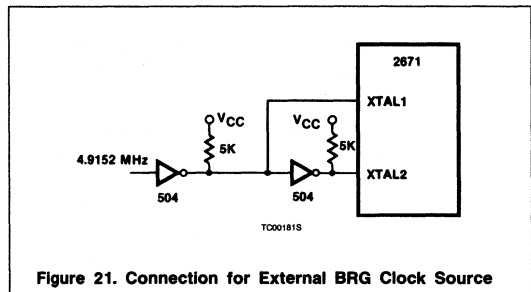

Figure 21. Connection for External BRG Clock Source

# Programmable Keyboard and Communication Controller (PKCC)

SCN2671

**Table 7. Register Format Summary**

	7	6	5	4	3	2	1	0
KMR	Test Mode		Rollover modes		Keyboard	Auto repeat		Tone select
	1 = Enable	00 = N-key with latched keys		0 = Encoded	0 = Disable		Key Matrix Size	Scan Time
	0 = Disable	01 = N-key 10 = Two keys 11 = Two key inhibit		1 = Nonen-coded	1 = Enable			
				KMR2	KMR1	128		
						128	2.5ms	1 = 2kHz
						80	6.4ms	
						80	1.6ms	
KSR	CONTROL	SHIFT	SHIFT LOCK	REPEAT	Keyboard Enabled	KOVR	KERR	KRDY
CMR	Operating Mode		Parity	Parity Mode		Stop Bits	Character Length	
	00 = Normal 01 = Auto echo 10 = Local loopback 11 = Remote loopback		0 = Odd/force 0 1 = Even/force 1	00 = With parity 01 = Force parity 10 = No parity 11 = Not allowed		0 = Two 1 = One	00 = 8 01 = 5 10 = 6 11 = 7	
BRR	Tx Clock source	Rx Clock source	Clock rate factor for external clocks		Baud rate select (BRR3 - BRR0 in hex)			
	0 = External 1 = Internal (BRG)	0 = External 1 = Internal (BRG)	00 = 16X 01 = 32X 10 = 64X 11 = 1X For internal clocks these bits specify the output frequency on pins 34 and 35 (Table 4).		0 = 50 1 = 110 2 = 134.5 3 = 150	4 = 200 5 = 300 6 = 600 7 = 1050	8 = 1200 9 = 1800 A = 2000 B = 2400	C = 4800 D = 9600 E = 19200 F = 38400
CSR	Parity error	Framing error	Overrun error	Received break	Transmit break	TxE <sub>MT</sub>	TxRDY	RxRDY
IMR/ISR	TxRDY	TxE <sub>MT</sub>	BREAK CHANGE	XINT	KERR	KRDY	KOVR	RxRDY
Reset Command Format	00X = No effect 010 = Set Rx <sub>E</sub> 011 = Reset Rx <sub>E</sub> 100 = Set Tx <sub>E</sub>	101 = Reset Tx <sub>E</sub> 110 = Set Tx <sub>E</sub> and Rx <sub>E</sub> 111 = Communications reset	Break detect change reset	Communications error reset	KOVR reset	KERR reset	Keyboard reset	
Miscellaneous Commands Format	Clear keyboard enable	Set keyboard enable	Clear shift lock	Set shift lock	Ring tone long	Ring tone short	Transmit timed break	Transmit character break



# SCN2672

## Programmable Video Timing Controller (PVTC)

### Product Specification

#### Microprocessor Products

#### DESCRIPTION

The Signetics SCN2672 Programmable Video Timing Controller (PVTC) is a programmable device designed for use in CRT terminals and display systems that employ raster scan techniques. The PVTC generates the vertical and horizontal timing signals necessary for the display of interlaced or non-interlaced data on a CRT monitor. It provides consecutive addressing to a user-specified display buffer memory domain and controls the CPU-display buffer interface for various buffer configuration modes. A variety of operating modes, display formats, and timing profiles can be implemented by programming the control registers in the PVTC.

A minimum CRT terminal system configuration consists of a PVTC, an SCN2671 Keyboard and Communication Controller (PKCC), an SCN2670 Display Character and Graphics Generator (DCGG), an SCB2673/2677 Video and Attributes Controller (VAC), a single-chip micro-computer such as the 8048, a display buffer RAM, and a small amount of TTL for miscellaneous address decoding, interface, and control. Typically, the package count for a minimum system is between 15 and 20 devices; system complexity can be enhanced by upgrading the microprocessor and expanding via the system address and data buses.

#### FEATURES

- 4MHz and 2.7MHz character rate versions
- Up to 256 characters per row
- 1 to 16 raster lines per character row
- Up to 128 character rows per frame
- Programmable horizontal and vertical sync generators
- Interlaced or non-interlaced operation
- Up to 16k RAM addressing for multiple page operation
- Automatic wraparound of RAM
- Addressable incrementable and readable cursor
- Programmable cursor size, position, and blink
- Split screen and horizontal scroll capability
- Light pen register
- Selectable buffer interface modes
- Dynamic RAM refresh
- Completely TTL compatible
- Single +5V power supply
- Power-on reset circuit

#### APPLICATIONS

- CRT terminals
- Word processing systems
- Small business computers
- Home computers

#### PIN CONFIGURATIONS

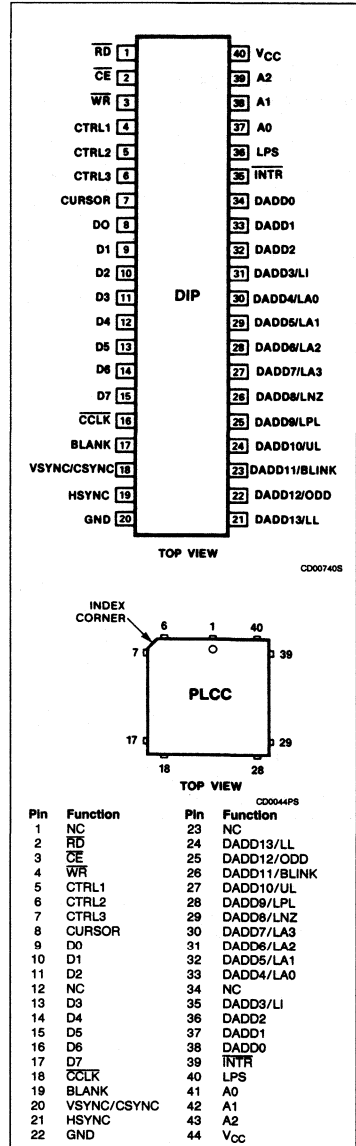

# Programmable Video Timing Controller (PVTC)

# SCN2672

## ORDERING INFORMATION

PACKAGES	$V_{CC} = +5V \pm 5\%$ , $T_A = 0^\circ C$ to $+70^\circ C$	
	4MHz	2.7MHz
Ceramic DIP	SCN2672BC4I40	SCN2672BC3I40
Plastic DIP	SCN2672BC4N40	SCN2672BC3N40
Plastic LCC	SCN2672BC4A44	SCN2672BC3A44

## FUNCTIONAL DESCRIPTION

As shown on the block diagram, the PVTC contains the following major blocks:

- Data bus buffer
- Interface Logic
- Operation Control
- Timing
- Display Control
- Buffer Control

## BLOCK DIAGRAM

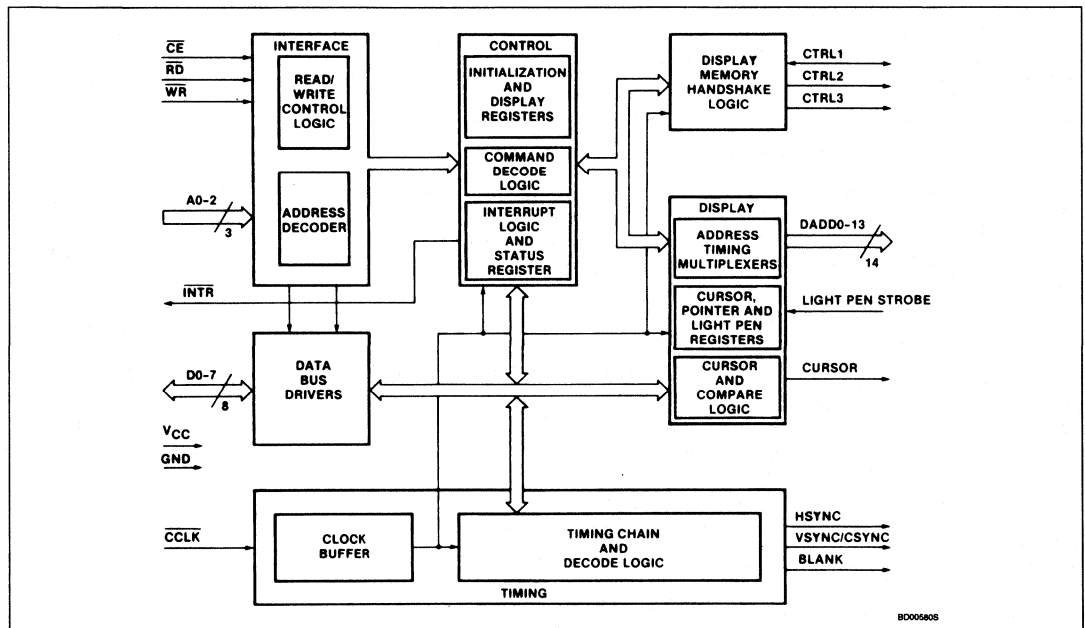

### Data Bus Driver

The data bus buffer provides the interface between the external and internal data buses. It is controlled by the operation control block to allow read and write operations to take place between the controlling CPU and the PVTC.

### Interface Logic

The interface logic contains address decoding and read and write circuits to permit communications with the microprocessor via the data bus buffer. The functions performed by the CPU read and write operations are as shown in Table 1.

**Table 1. PVTC Addressing**

A2	A1	A0	READ ( $\overline{RD} = 0$ )	WRITE ( $\overline{WR} = 0$ )
0	0	0	Interrupt register	Initialization registers <sup>1</sup>
0	0	1	Status register	Command register
0	1	0	Screen start address lower register	Screen start address lower reg.
0	1	1	Screen start address upper register	Screen start address upper reg.
1	0	0	Cursor address lower register	Cursor address lower register
1	0	1	Cursor address upper register	Cursor address upper register
1	1	0	Light pen address lower register	Display pointer address lower reg.
1	1	1	Light pen address upper register	Display pointer address upper reg.

**NOTE:**

1. There are 11 initialization registers which are accessed sequentially via a single address. The PVTC maintains an internal pointer to these registers which is incremented after each write at this address until the last register (IR10, the split screen register) is accessed. The pointer then continues to point to the split screen register. Upon power-up or a master reset command, the internal pointer is reset to point to the first register (IR0) of the initialization register group. The internal pointer can also be preset to any register of the group via the 'load IR address pointer' command.

## Programmable Video Timing Controller (PVTC)

SCN2672

## PIN DESCRIPTION

MNEMONIC	PIN NO.		TYPE	NAME AND FUNCTION
	DIP	PLCC		
A0 – A2	37 – 39	41 – 43	I	<b>Address Lines:</b> Used to select PVTC internal registers for read/write operations and for commands.
D0 – D7	8 – 15	9 – 11, 13 – 17	I/O	<b>8-Bit Bidirectional 3-State Data Bus:</b> Bit 0 is the LSB and bit 7 is the MSB. All data, command, and status transfers between the CPU and the PVTC take place over this bus. The direction of the transfer is controlled by the $\overline{RD}$ and $\overline{WR}$ inputs when the $\overline{CE}$ input is low. When the $\overline{CE}$ input is high, the data bus is in the 3-State condition.
$\overline{RD}$	1	2	I	<b>Read Strobe:</b> Active low input. A low on this pin while $\overline{CE}$ is low causes the contents of the register selected by A0 – A2 to be placed on the data bus. The read cycle begins on the leading (falling) edge of $\overline{RD}$ .
$\overline{WR}$	3	4	I	<b>Write Strobe:</b> Active low input. A low on this pin while $\overline{CE}$ is also low causes the contents of the data bus to be transferred to the register selected by A0 – A2. The transfer occurs on the trailing (rising) edge of $\overline{WR}$ .
$\overline{CE}$	2	3	I	<b>Chip Enable:</b> Active low input. When low, data transfers between the CPU and the PVTC are enabled on D0 – D7 as controlled by the $\overline{WR}$ , $\overline{RD}$ , and A0 – A2 inputs. When $\overline{CE}$ is high, the PVTC is effectively isolated from the data bus and D0 – D7 are placed in the 3-State condition.
$\overline{CLK}$	16	18	I	<b>Character Clock:</b> Timing signal derived from the video dot clock which is used to synchronize the PVTC's timing functions.
HSYNC	19	21	O	<b>Horizontal Sync:</b> Active high output which provides video horizontal sync pulses. The timing parameters are programmable.
VSNC/CSYNC	18	20	O	<b>Vertical Sync/Composite Sync:</b> A control bit selects either vertical or composite sync pulses on this active high output. When CSYNC is selected, equalization pulses are included. The timing parameters are programmable.
BLANK	17	19	O	<b>Blank:</b> This active high output defines the horizontal and vertical borders of the display. Display control signals which are output on DADD3 through DADD13 are valid on the trailing edge of BLANK.
CURSOR	7	8	O	<b>Cursor Gate:</b> This active high output becomes active for a specified number of scan lines when the address contained in the cursor registers match the address output on DADD0 through DADD13. The first and last lines of the cursor and a blink option are programmable.
$\overline{INTR}$	35	39	O	<b>Interrupt Request:</b> Open drain output which supplies an active low interrupt request from any of five maskable sources. This pin is inactive after power-on reset or a master reset command.
LPS	36	40	I	<b>Light Pen Strobe:</b> Positive edge-triggered input indicating a light pen hit. Causes the current value of the display address to be strobed into the light pen register.
CTRL1	4	5	I/O	<b>Handshake Control 1:</b> In independent mode, provides an active low write data buffer (WDB) output which strobes data from the interface latch into the display memory. In transparent and shared modes, this is an active low processor bus request ( $\overline{PBREQ}$ ) input which indicates that the CPU desires to access the display memory. This pin must be tied high when operating in row buffer mode.
CTRL2	5	6	O	<b>Handshake Control 2:</b> In independent mode, provides an active low read data buffer (RDB) output which strobes data from the display memory into the interface latch. In transparent and shared modes, this is an active low bus external enable ( $\overline{BEXT}$ ) output which indicates that the PVTC has relinquished control of the display memory (DADD0 – DADD13 are in the 3-State condition) in response to a CPU bus request. $\overline{BEXT}$ also goes low in response to a 'display off and float DADD' command. In row buffer mode, it is an active low bus request ( $\overline{BREQ}$ ) output which halts the CPU during a line DMA.
CTRL3	6	7	O	<b>Handshake Control 3:</b> In independent mode, provides the active low buffer chip enable (BCE) signal to the display memory. In transparent and shared modes provides an active low bus acknowledge ( $\overline{BACK}$ ) output which serves as a ready signal to the CPU in response to a processor bus request. In row buffer mode, this is an active high memory bus control

## Programmable Video Timing Controller (PVTC)

SCN2672

## PIN DESCRIPTION (Continued)

MNEMONIC	PIN NO.		TYPE	NAME AND FUNCTION
	DIP	PLCC		
DADD0 - DADD13	34 - 21	38 - 35 33 - 24	O	(MBC) output which configures the system for the DMA transfer of one row of character codes from system memory to the row display buffer. <b>Display Address:</b> Used by the PVTC to address up to 16k of display memory. These outputs are floated at various times depending on the buffer mode. Various control signals are multiplexed on DADD3 thru DADD13 and are valid at the trailing edge of BLANK. These control signals are: <b>DADD3/LI</b> <b>Line Interface:</b> Replaces DADD4/LA0 as the least significant line address for the interlaced sync and video applications. A low indicates an even row of an even field or an odd row of an odd field. <b>DADD4 - DADD7/LA0 - LA3</b> <b>Line Address:</b> Provides the number of the current scan line within each character row. <b>DADD8/LNZ</b> <b>Line Zero:</b> Asserted before the first scan line in each character row. <b>DADD9/LPL</b> <b>Light Pen Line:</b> Asserted before the scan line which matches the programmed light pen line position (line 3, 5, 7, or 9). <b>DADD10/UL</b> <b>Underline:</b> Asserted before the scan line which matches the programmed underline position (lines 0 thru 15). <b>DADD11/BLINK</b> <b>Blink frequency:</b> Provides an output divided down from the vertical sync rate. <b>DADD12/ODD</b> <b>Odd Field:</b> Active high signal which is asserted before each scan line of the odd field when interlace is specified. <b>DADD13/LL</b> <b>Last Line:</b> Asserted before the last scan line of each character row.
V <sub>CC</sub>	40	44	I	<b>Power Supply:</b> +5V ±5% power input.
GND	20	22	I	<b>Ground:</b> Signal and power ground input.

**Operation Control**

The operation control section decodes configuration and operation commands from the CPU and generates appropriate signals to other internal sections to control the overall device operation. It contains the timing and display registers which configure the display format and operating mode, the interrupt logic, and the status register which provides operational feedback to the CPU.

**Timing**

The timing section contains the counters and decoding logic necessary to generate the monitor timing outputs and to control the display format. These timing parameters are selected by programming of the initialization registers.

**Display Control**

The display control section generates linear addressing for up to 16k bytes of display memory. Internal comparators limit the portion of the memory which is displayed to programmed values. Additional functions performed in this section include cursor position-

ing, storage of light pen 'hit' location, and address comparisons required for generation of timing signals and the split screen interrupt.

**Buffer Control**

The buffer control section generates three signals which control the transfer of data between the CPU and the display buffer memory. Four system configurations requiring four different 'handshaking' schemes are supported. These are described below.

**SYSTEM CONFIGURATIONS**

Figure 1 illustrates the block diagram of a typical display terminal using the Signetics 2670, 2671, 2672, and 2673/2677 CRT terminal devices. In this system, the CPU examines inputs from the data communications line and the keyboard and places the data to be displayed in the display buffer memory. This buffer is typically a RAM which holds the data for a single or multiple screenload (page) or for a single character row.

The PVTC supports four common system configurations of display buffer memory: the independent, transparent, shared, and row buffer modes. The first three modes utilize a single or multiple page RAM and differ primarily in the means used to transfer display data between the RAM and the CPU. The row buffer mode makes use of a single row buffer (which can be a shift register or a small RAM) that is updated in real-time to contain the appropriate display data.

The user programs bits 0 and 1 of IR0 to select the mode best suited for the system environment. The CNTRL1-3 outputs perform different functions for each mode and are named accordingly in the description of each mode.

**Independent Mode**

The CPU to RAM interface configuration for this mode is illustrated in Figure 2. Transfer of data between the CPU and display memory is accomplished via a bidirectional latched port and is controlled by the signals read data buffer ( $\overline{RDB}$ ), write data buffer ( $\overline{WDB}$ ), and

# Programmable Video Timing Controller (PVTc)

# SCN2672

2

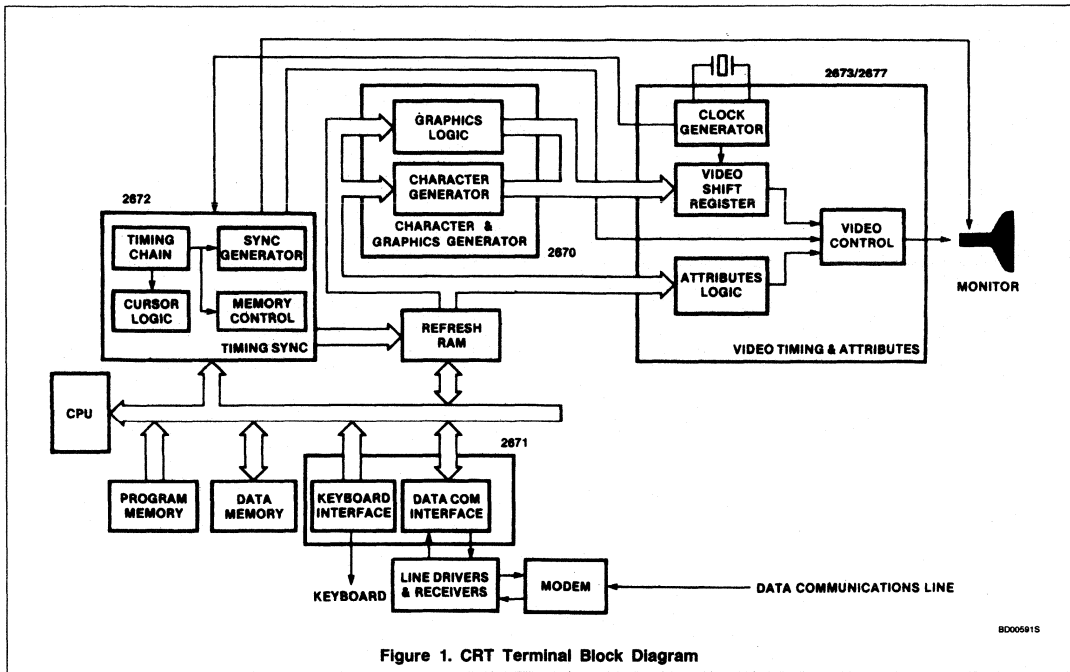

Figure 1. CRT Terminal Block Diagram

BD005915

buffer chip enable ( $\overline{BCE}$ ). This mode provides a non-contention type of operation that does not require address multiplexers. The CPU does not address the memory directly—the read or write operation is performed at the address contained in the cursor address register or the pointer address register as specified by the CPU. The PVTc enacts the data transfers during blanking intervals in order to prevent visual disturbances of the displayed data.

For a data buffer write command, the  $\overline{WDB}$  signal will go active on the rising edge of character clock ( $\overline{CCLK}$ ) and will remain so until the next  $\overline{CCLK}$  rising edge.  $\overline{BCE}$  is always in the active state except before and after a  $\overline{WDB}$  command. When a write has been executed,  $\overline{BCE}$  becomes inactive on the falling edge of  $\overline{CCLK}$ . When the write occurs ( $\overline{WDB}$  active) on the next rising edge,  $\overline{BCE}$  also becomes active.  $\overline{BCE}$  and  $\overline{WDB}$  both become inactive on the rising edge of  $\overline{CCLK}$ .  $\overline{BCE}$  will then return to the active state on the next falling edge if there is no other write command to be executed.

The CPU manages the data transfers by supplying commands to the PVTc. The commands used are:

1. Read/Write at pointer address.

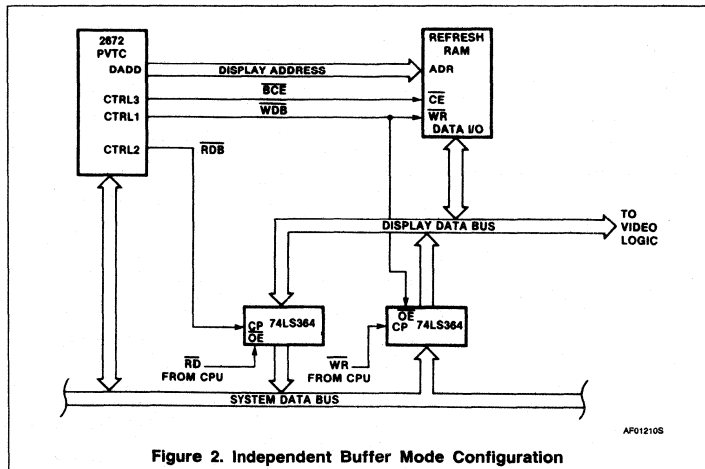

Figure 2. Independent Buffer Mode Configuration

AP012105

2. Read/Write at cursor address (with optional increment of address).
  3. Write from cursor address to pointer address.
- The operational sequence for a write operation is:
1. CPU checks RDFLG status bit to assure that any previous operation has been completed.
  2. CPU loads data to be written to display memory into the interface latch.
  3. CPU writes address into cursor or pointer registers.

## Programmable Video Timing Controller (PVTC)

SCN2672

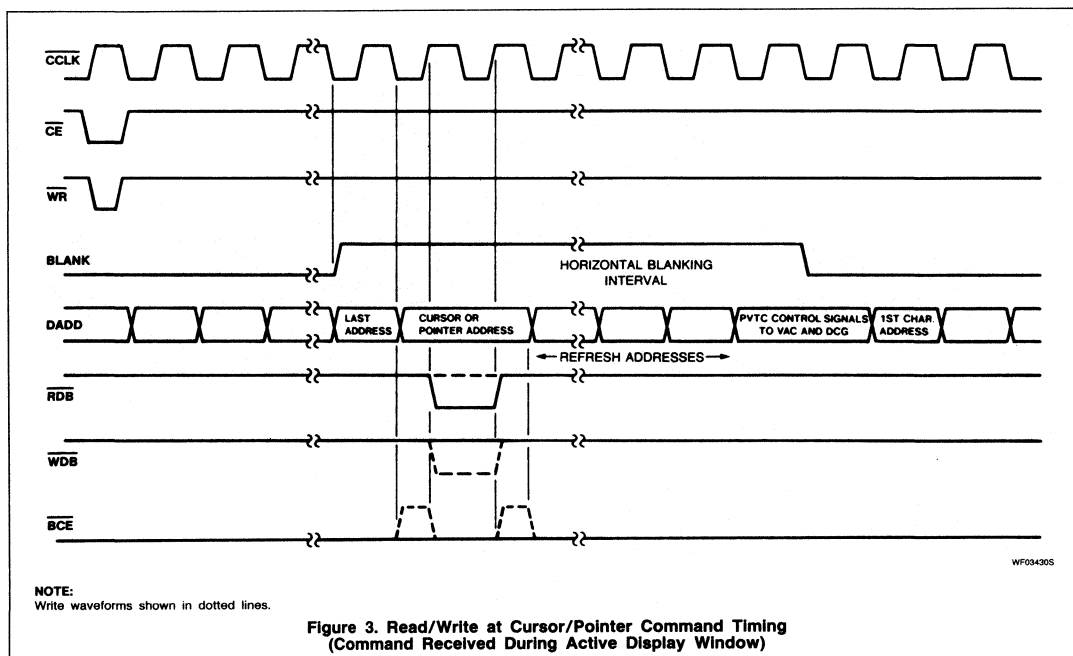

4. CPU issues 'write at cursor with/without increment' or 'write at pointer' command.
5. PVTC generates control signals and outputs specified address to perform requested operation. Data is copied from the interface latch into the memory.
6. PVTC sets RDFLG status to indicate that the write is completed.

Similarly, a read operation proceeds as follows:

1. Steps 1 and 3 as above.
2. CPU issues 'read at cursor with/without increment' or 'read at pointer' command.
3. PVTC generates control signals and outputs specified address to perform requested operation. Data is copied from memory to the interface latch and PVTC sets RDFLG status to indicate that the read is completed.
4. CPU checks RDFLG status to see if operation is completed.
5. CPU reads data from interface latch.

Loading the same data into a block of display memory is accomplished via the 'write from cursor to pointer' command:

1. CPU checks RDFLG status bit to assure that any previous operation has been completed.
2. CPU loads data to be written to display memory into the interface latch.

3. CPU writes beginning address of memory block into cursor address register and ending address of block into pointer address register.
4. CPU issues 'write from cursor to pointer' command.
5. PVTC generates control signals and outputs block addresses to copy data from the interface latch into the specified block of memory.
6. PVTC sets RDFLG status to indicate that the block write is completed.

Similar sequences can be implemented on an interrupt driven basis using the READY interrupt output to advise the CPU that a previously requested command has been completed.

Two timing sequences are possible for the 'read/write at cursor/pointer' commands. If the command is given during the active display window (defined as first scan line of the first character row to the last scan line of the last character row), the operation takes place during the next horizontal blanking interval, as illustrated in Figure 3. If the command is given during the vertical blanking interval, or while the display has been commanded blanked, the operation takes place immediately. In the latter case, the execution time for the command is approximately one microsecond plus six (6) character clocks (see Figure 4).

Timing for the 'write from cursor to pointer' operation is shown in Figure 5. The BLANK output is asserted automatically and remains asserted until the horizontal retrace interval following completion of the command. The memory is filled at a rate of one location per two character times, plus a small amount of overhead.

### Shared And Transparent Buffer Modes

In these modes the display buffer RAM is a part of the CPU memory domain and is addressed directly by the CPU. Both modes use the same hardware configuration with the CPU accessing the display buffer via 3-State drivers (see Figure 6). The processor bus request (PBREQ) control signal informs the PVTC that the CPU is requesting access to the display buffer. In response to this request, the PVTC raises bus acknowledge (BACK) until its bus external (BEXT) output has freed the display address and data buses for CPU access. BACK, which can be used as a 'hold' input to the CPU, is then lowered to indicate that the CPU can access the buffer.

In transparent mode, the PVTC delays the granting of the buffer to the CPU until a vertical or horizontal blanking interval, thereby causing minimum disturbance of the display. In shared mode, the PVTC will blank the display and grant immediate access to the CPU. Timing for these modes is illustrated in Figures 7, 8, and 9.

Programmable Video Timing Controller (PVTIC)

SCN2672

2

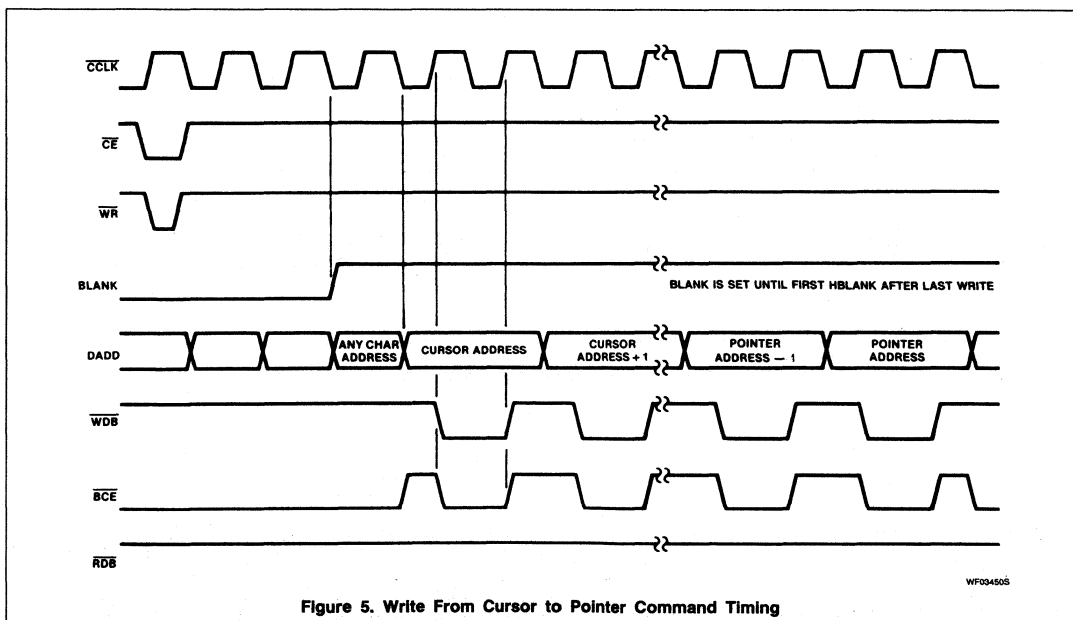
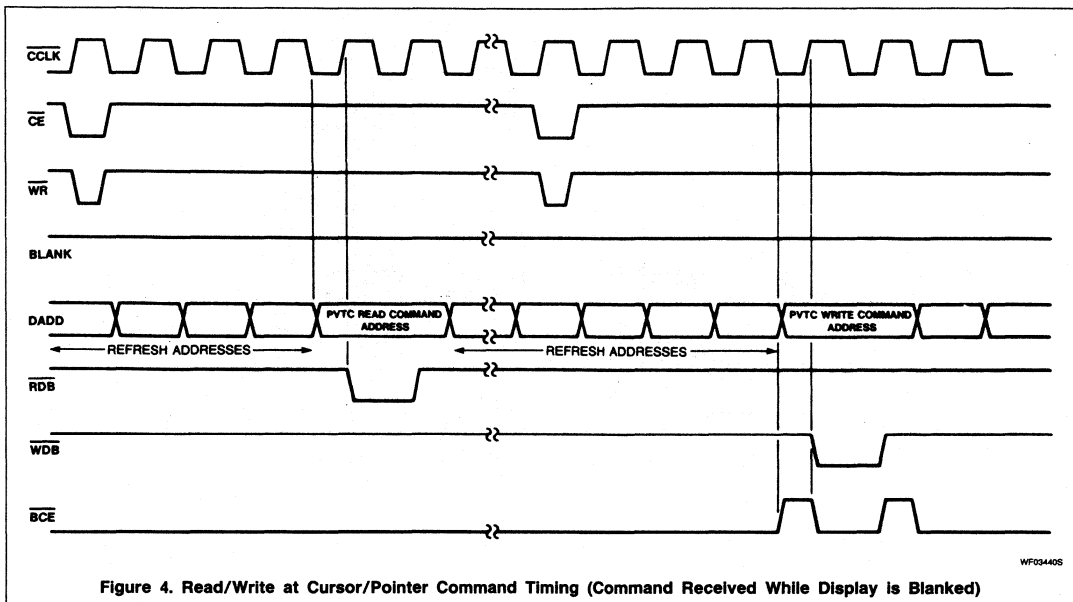

Programmable Video Timing Controller (PVTC)

SCN2672

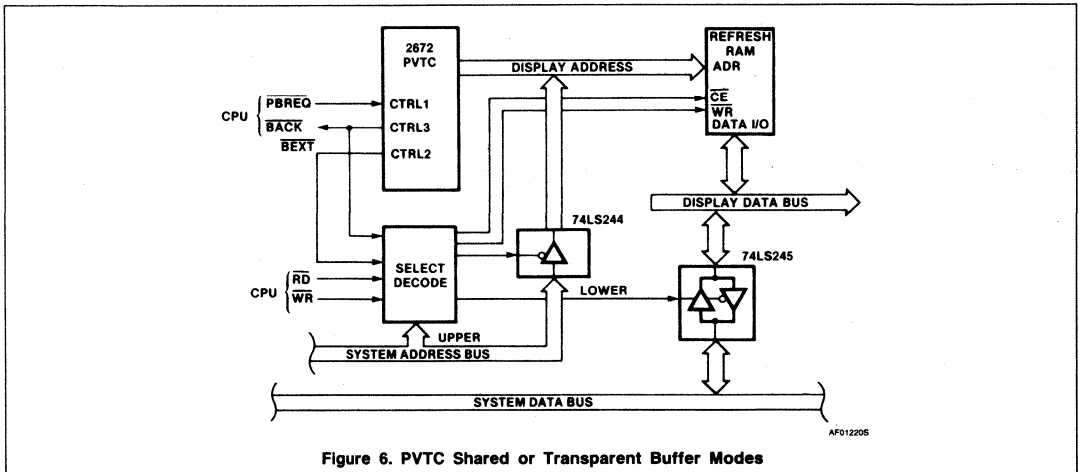
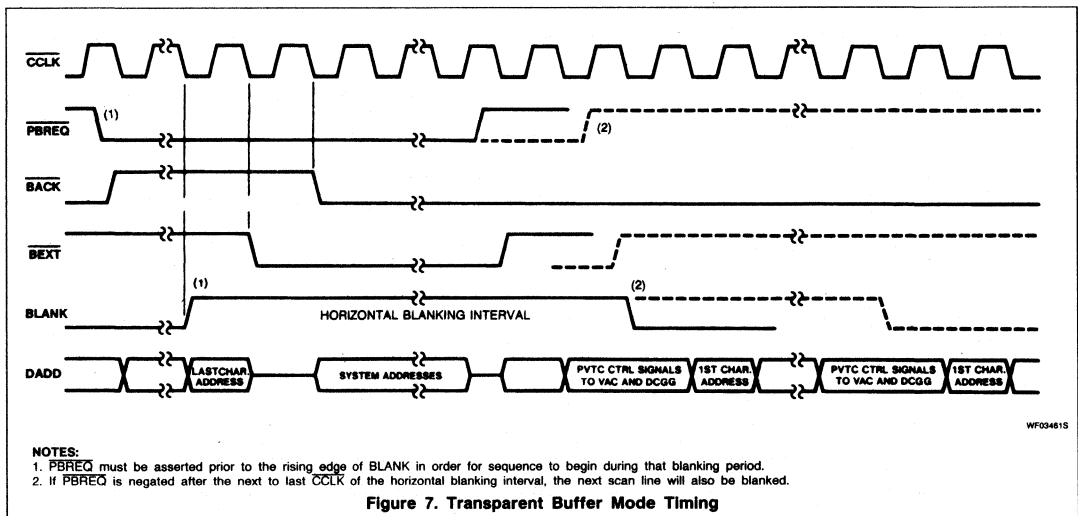

Figure 6. PVTC Shared or Transparent Buffer Modes



NOTES:

1. PBREQ must be asserted prior to the rising edge of BLANK in order for sequence to begin during that blanking period.
2. If PBREQ is negated after the next to last CCLK of the horizontal blanking interval, the next scan line will also be blanked.

Figure 7. Transparent Buffer Mode Timing



# Programmable Video Timing Controller (PVTIC)

SCN2672

**2**

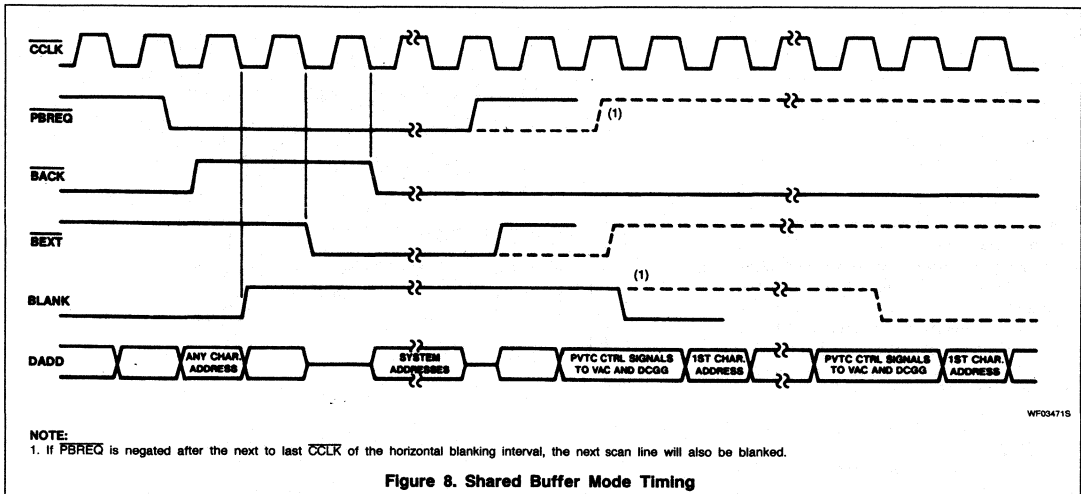

Figure 8. Shared Buffer Mode Timing

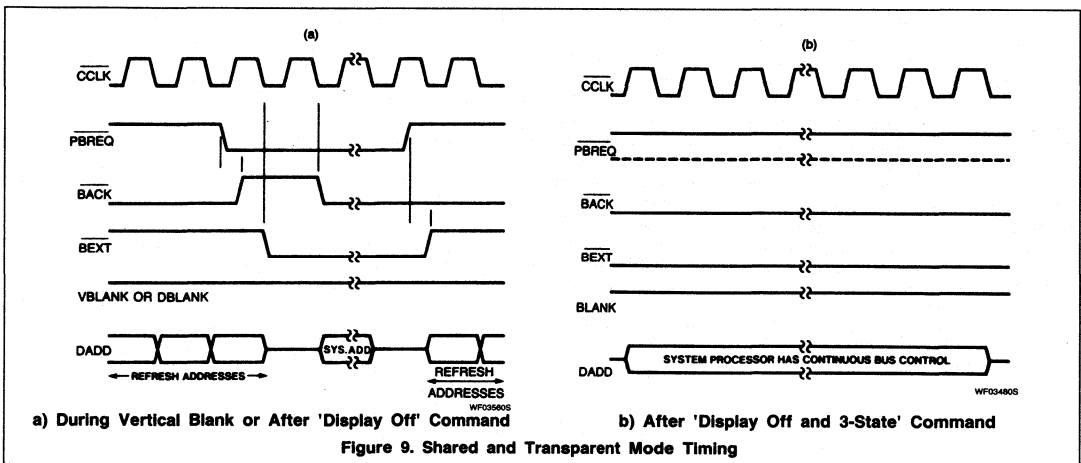

Figure 9. Shared and Transparent Mode Timing

# Programmable Video Timing Controller (PVTC)

SCN2672

## Row Buffer Mode

Figures 10 and 11 show the timing and a typical hardware implementation for the row buffer mode. During the first scan line (line 0) of each character row, the PVTC halts the CPU and DMA's the next row of character data from the system memory to the row buffer memory. The PVTC then releases the CPU and displays the row buffer data for the programmed number of scan lines. The bus request control ( $\overline{BREQ}$ ) signal informs the CPU that character addresses and the memory bus control (MBC) signal will start at the next falling edge of BLANK. The CPU must release the address and data buses before this time to prevent bus contention. After the row of character data is transferred to the row buffer RAM,  $\overline{BREQ}$  returns high to grant memory control back to the CPU.

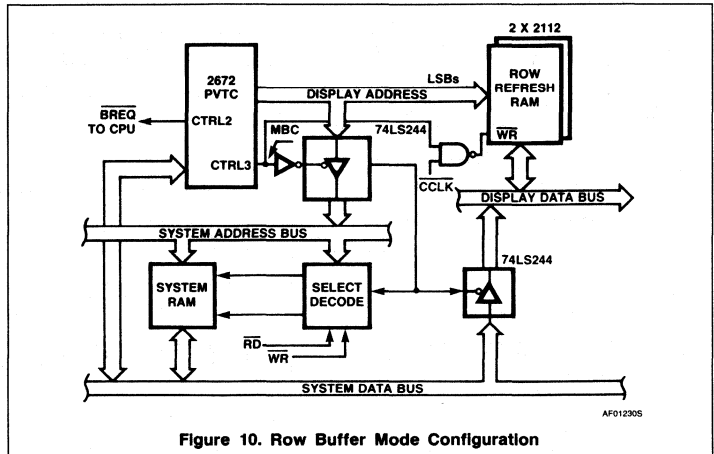

Figure 10. Row Buffer Mode Configuration

## OPERATION

After power is applied, the PVTC will be in an inactive state. Two consecutive 'master reset' commands are necessary to release this circuitry and ready the PVTC for operation. Two register groups exist within the PVTC: the initialization registers and the display control registers. The initialization registers select the system configuration, monitor timing, cursor shape, display memory domain, and screen format. These are loaded first and normally require no modification except for certain special visual effects. The display control registers specify the memory address of the base character (upper left corner of screen), the cursor position, and the pointer address for independent memory access mode. These usually require modification during operation.

After initial loading of the two register groups, the PVTC is ready to control the monitor

screen. Prior to executing the PVTC commands which turn on the display and cursor, the user should load the display memory with the first data to be displayed. During operation, the PVTC will sequentially address the display memory within the limits programmed into its registers. The memory outputs character codes to the system character and graphics generation logic, where they are converted to the serial video stream necessary to display the data on the CRT. The user effects changes to the display by modifying the contents of the display memory, the PVTC display control and command registers, and the initialization registers, if required. Interrupts and status conditions generated by the PVTC supply the 'handshaking' information necessary for the CPU to effect the display changes in the proper time frame.

## Initialization Registers

There are 11 initialization registers (IR0 - IR10) which are accessed sequentially via a single address. The PVTC maintains an internal pointer to these registers which is incremented after each write at this address until the last register (IR10, the split screen register) is accessed. The pointer then continues to point to the split screen register. Upon power-up or a master reset command, the internal pointer is reset to point to the first register (IR0) of the initialization register group. The internal pointer can also be preset to any register of the group via the 'load IR address pointer' command. These registers are write only and are used to specify parameters such as the system configuration, display format, cursor shape, and monitor timing. Register formats are shown in Table 2.

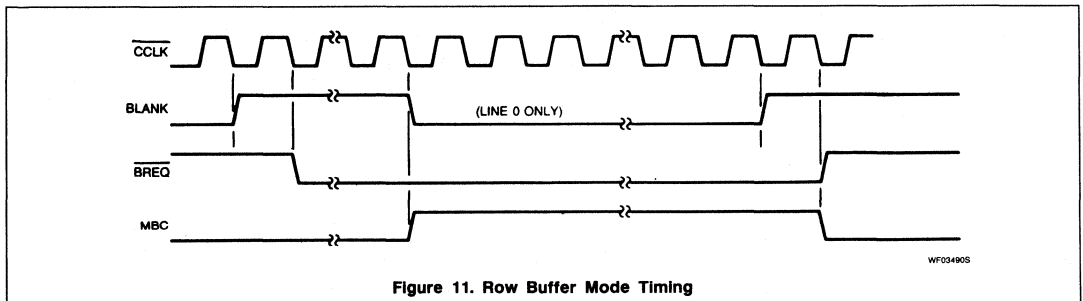

Figure 11. Row Buffer Mode Timing

## Programmable Video Timing Controller (PVTC)

SCN2672

Table 2. Initialization Register Bit Formats

	BIT 7	BIT 6	BIT 5	BIT 4	BIT 3	BIT 2	BIT 1	BIT 0	
IR0	NOT USED	SCAN LINES PER CHARACTER ROW				SYNC SELECT 0 = VSYNC 1 = CSYNC	BUFFER MODE SELECT		
		NON-INTERLACED		INTERLACED			00 = INDEPENDENT 01 = TRANSPARENT 10 = SHARED 11 = ROW		
		0000 = 1 LINE 0001 = 2 LINES 0010 = 3 LINES .	0000 = UNDEFINED 0001 = 5 LINES 0010 = 7 LINES .						
		1110 = 15 LINES 1111 = 16 LINES	1110 = 31 LINES 1111 = UNDEFINED						
IR1	INTERLACE ENABLE	EQUALIZING CONSTANT							
	0 = NON-INT 1 = INTER.	00000000 = 1 CCLK 00000001 = 2 CCLK .	CALCULATED FROM: $EC = 0.5(H_{ACT} + H_{FP} + H_{SYNC} + H_{BP}) - 2(H_{SYNC})$						
		11111110 = 127 CCLK 11111111 = 128 CCLK							
IR2	NOT USED	HORIZONTAL SYNC WIDTH				HORIZONTAL BACK PORCH			
		0000 = 2 CCLK 0001 = 4 CCLK .				000 = 1 CCLK 001 = 5 CCLK .			
		1110 = 30 CCLK 1111 = 32 CCLK				110 = 25 CCLK 111 = 29 CCLK			
IR3	VERTICAL FRONT PORCH				VERTICAL BACK PORCH				
	000 = 4 SCAN LINES 001 = 8 SCAN LINES .				00000 = 4 SCAN LINES 00001 = 6 SCAN LINES .				
	110 = 28 SCAN LINES 111 = 32 SCAN LINES				11110 = 64 SCAN LINES 11111 = 66 SCAN LINES				
IR4	CHARACTER BLINK RATE 0 = 1/16 VSYNC 1 = 1/32 VSYNC	ACTIVE CHARACTER ROWS PER SCREEN (NOTE 1)							
		00000000 = 1 ROW 00000001 = 2 ROWS .							
		11111110 = 127 ROWS 11111111 = 128 ROWS							

**NOTE:**

In interlace mode with odd total character rows per screen the last character row will be the programmed scan lines per character row minus one.

2

# Programmable Video Timing Controller (PVTC)

SCN2672

**Table 2. Initialization Register Bit Formats (Continued)**

	BIT 7	BIT 6	BIT 5	BIT 4	BIT 3	BIT 2	BIT 1	BIT 0
IR5	<b>ACTIVE CHARACTERS PER ROW</b>							
	00000010 = 3 CHARACTERS 00000011 = 4 CHARACTERS . . 11111110 = 255 CHARACTERS 11111111 = 256 CHARACTERS							
IR6	<b>FIRST LINE OF CURSOR</b>				<b>LAST LINE OF CURSOR</b>			
	0000 = SCAN LINE 0 0001 = SCAN LINE 1 . . 1110 = SCAN LINE 14 1111 = SCAN LINE 15				0000 = SCAN LINE 0 0001 = SCAN LINE 1 . . 1110 = SCAN LINE 14 1111 = SCAN LINE 15			
IR7	<b>LIGHT PEN LINE</b>		<b>CURSOR BLINK</b>	<b>DOUBLE HEIGHT CHAR.</b>	<b>UNDERLINE POSITION</b>			
	00 = SCAN LINE 3 01 = SCAN LINE 5 10 = SCAN LINE 7 11 = SCAN LINE 9		0 = NO 1 = YES	0 = NO 1 = YES	0000 = SCAN LINE 0 0001 = SCAN LINE 1 . . 1110 = SCAN LINE 14 1111 = SCAN LINE 15			
IR8	<b>DISPLAY BUFFER FIRST ADDRESS LSB'S</b>							
	H'000' = 0 H'001' = 1 . . H'FFE' = 4,094 H'FFF' = 4,095							
NOTE: MSB'S ARE IN IR9[3:0]								
IR9	<b>DISPLAY BUFFER LAST ADDRESS</b>				<b>DISPLAY BUFFER FIRST ADDRESS MSB'S</b>			
	0000 = 1,023 0001 = 2,047 . . 1110 = 15,359 1111 = 16,383				SEE IR8			
IR10	<b>CURSOR BLINK RATE</b>		<b>SPLIT SCREEN INTERRUPT ROW</b>					
	0 = 1/16 VSYNC 1 = 1/32 VSYNC		00000000 = ROW 0 00000001 = ROW 1 . . 11111110 = ROW 126 11111111 = ROW 127					

# Programmable Video Timing Controller (PVTC)

SCN2672

## IR0[6:3] — Scan Lines Per Character Row

Both interlaced and non-interlaced scanning are supported by the PVTC. For interlaced mode, two different formats can be implemented, depending on the interconnection between the PVTC and the character generator (see IR1[7]). This field defines the number of scan lines used to compose a character row for each technique. As scanning occurs, the scan line count is output on the LA0 – LA3 and LI pins.

## IR0[2] — VS/CS Enable

This bit selects either vertical sync pulses or composite sync pulses on the VSYNC/CSYNC output (pin 18). The composite sync waveform conforms to EIA RS170 standards, with the vertical interval composed of six equalizing pulses, six vertical sync pulses, and six more equalizing pulses.

## IR0[1:0] — Buffer Mode Select

Four buffer memory modes may be selectively enabled to accommodate the desired system configuration. See System Configurations.

## IR1[7] — Interface Enable

Specifies interlaced or noninterlaced timing operation. Two modes of interlaced operation are available, depending on whether LA0 – LA3 or LI, LA0 – LA2 are used as the line address for the character generator. The resulting displays are shown in Figure 12.

For 'interlaced sync' operation, the same information is displayed in both odd and even fields, resulting in enhanced readability. The PVTC outputs successive line numbers in ascending order on the LA0 – LA3 lines, one per scan line for each field.

The 'interlaced sync and video' format doubles the character density on the screen. The PVTC outputs successive line numbers in ascending order on the LI, LA0 – LA2 lines, one per scan line for each field, but alternates beginning the count with even and odd line numbers. In the interlaced sync and video mode, the number of scan lines per character row is always odd. Assume that the first character row is row 0 (even). When in the odd field, the scan line numbers being displayed are even for even character rows and odd for odd character rows. When in the even field, the scan line numbers being displayed are odd for even character rows and even for odd character rows (see Figure 12c). This provides balanced beam currents in the odd

and even fields, thus minimizing character variations due to different loading of the CRT anode supply between fields.

## IR1[6:0] — Equalizing Constant

This field indirectly defines the horizontal front porch and is used internally to generate the equalizing pulses for the RS170 compatible CSYNC. The value for this field is the total number of character clocks (CCLK) during a horizontal line period divided by two, minus two times the number of character clocks in the horizontal sync pulse:

$$EC = \frac{H_{ACT} + H_{FP} + H_{SYNC} + H_{BP}}{2} - 2(H_{SYNC})$$

The definition of the individual parameters is illustrated in Figure 13. The minimum value of  $H_{FP}$  is two character clocks.

Note that when using the 2673/2677 VAC, the blank pulse is delayed three CCLKs relative to the HSYNC pulse. Because of this delay, the actual HFP and HBP values will be different from the values programmed into the PVTC. The actual HFP will be decreased by 3 character clocks. The actual HBP will be increased by 3 character clocks.

## IR2[6:3] — Horizontal Sync Pulse Width

This field specifies the width of the HSYNC pulse in CCLK periods.

## IR2[2:0] — Horizontal Back Porch

This field defines the number of CCLKs between the trailing edge of HSYNC and the trailing edge of BLANK.

## IR3[7:5] — Vertical Front Porch

Programs the number of scan line periods between the rising edges of BLANK and VSYNC during a vertical retrace interval. The width of the VSYNC pulse is fixed at three scan lines.

## IR3[4:0] — Vertical Back Porch

This field determines the number of scan line periods between the falling edges of the VSYNC and BLANK outputs.

## IR4[7] — Character Blink Rate

Specifies the frequency for the character blink attribute timing. The blink rate can be specified as  $\frac{1}{16}$  or  $\frac{1}{32}$  of the vertical field rate. The timing signal has a duty cycle of 75% and is multiplexed onto the DADD11/BLINK output at the falling edge of each BLANK.

## IR4[6:0] — Character Rows Per Screen

This field defines the number of character rows to be displayed. This value multiplied by

the scan lines per character row, plus the vertical front and back porch values, and the vertical sync pulse width (three scan lines) is the vertical scan period in scan lines.

## IR5[7:0] — Active Characters Per Row

This field determines the number of characters to be displayed on each row of the CRT screen. The sum of this value, the horizontal front porch, the horizontal sync width, and the horizontal back porch is the horizontal scan period in CCLKs.

## IR6[7:4], IR6[3:0] — First and Last Scan Line of Cursor

These two fields specify the height and position of the cursor on the character block. The 'first' line is the topmost line when scanning from the top to the bottom of the screen. The value of the first line of cursor must be less than the last line of cursor value.

## IR7[7:6] — Light Pen Line Position

This field defines which of four scan lines of the character row will be used for the light pen strike-through attribute by the 2673/2677 VAC. The timing signal is multiplexed onto the DADD9/LPL output during the falling edge of BLANK.

## IR7[5] — Cursor Blink Enable

This bit controls whether or not the cursor output pin will be blinked at the selected rate (IR10[7]). The blink duty cycle for the cursor is 50%.

## IR7[4] — Double Height Character Row Enable

If enabled, the scan line count will be repeated twice in succession, causing the height of the character row to double. This bit can be changed at any time but will only become effective at the beginning of the character row following the time it is changed. This allows selected character rows to be of double height. The split screen interrupt can be used to notify the CPU when to effectuate changes to this bit. For each double height row which replaces a normal row, one row count should be subtracted from the 'character rows per screen' field (IR4) to maintain the same total number of scan lines per field.

## IR7[3:0] — Underline Position

This field defines which scan line of the character row will be used for the underline attribute by the 2673/2677 VAC. The timing signal is multiplexed onto the DADD10/UL output during the falling edge of BLANK.

# 2

# Programmable Video Timing Controller (PVTC)

SCN2672

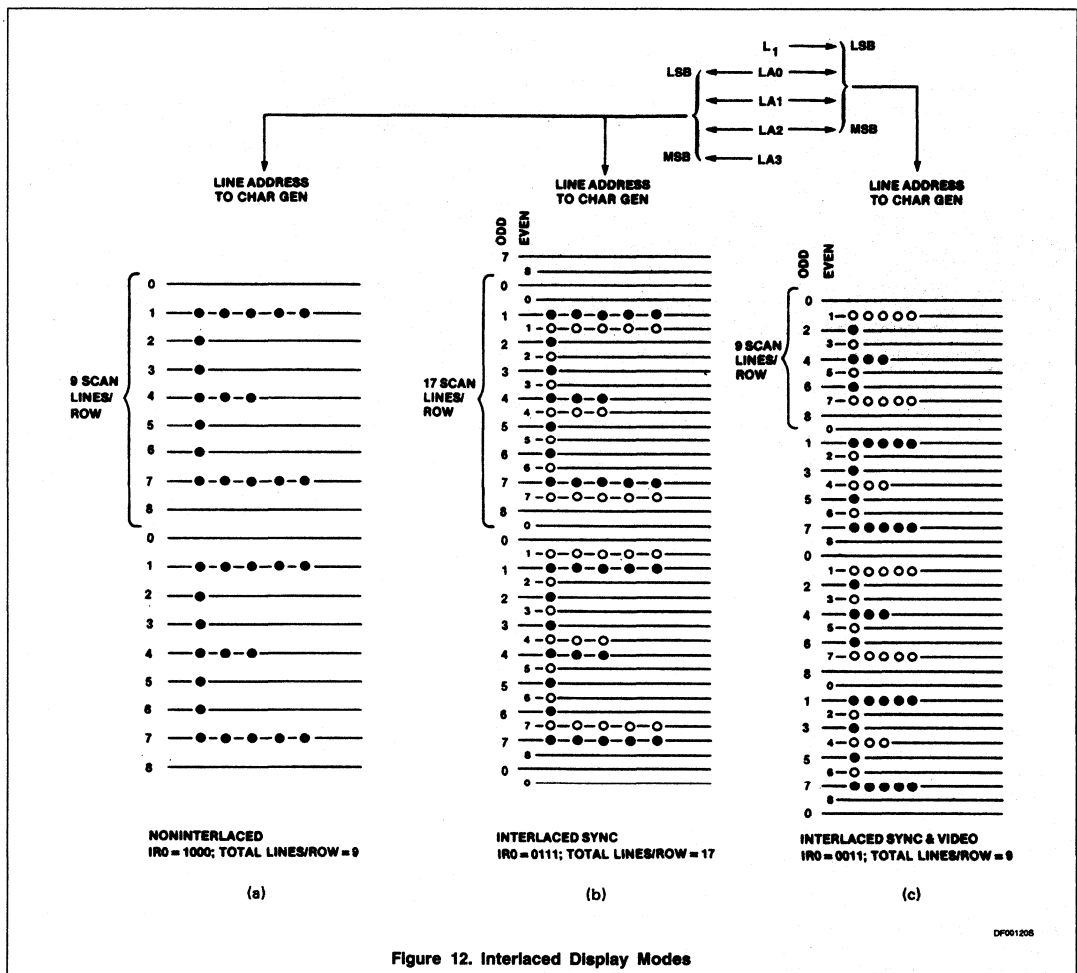

Figure 12. Interlaced Display Modes

**IR9[3:0], IR8[7:0] — Display Buffer First Address**

**IR9[7:4] — Display Buffer Last Address**

These two fields define the area within the buffer memory where the display data will reside. When the data at the 'display buffer last address' is displayed, the PVTC will wraparound and obtain the data to be displayed at the next screen position from the 'display buffer first address'. If 'last address' is the end of a character row and a new screen start address has been loaded into the screen start register, or if 'last address' is the last character position of the screen, the

next data is obtained from the address contained in the screen start register.

Note that there is no restriction in displaying data from other areas of the addressable memory. Normally, the area between these two bounds is used for data which can be overwritten (e.g., as a result of scrolling), while data that is not to be overwritten would be contained outside these bounds and accessed by means of the split screen interrupt feature of the PVTC.

**IR10[7] — Cursor Blink Rate**

The cursor blink rate can be specified at  $\frac{1}{16}$  or  $\frac{1}{32}$  of the vertical scan frequency. Blink is effective only if blink is enabled by IR7[5].

**IR10[6:0] — Split Screen Interrupt**

The split screen interrupt can be used to provide special screen effects such as a row of double height characters or to change the normal addressing sequence of the display memory. The contents of this field are compared, in real-time, to the current character row number. Upon a match, the PVTC sets the split screen status bit, and issues an interrupt request if so programmed. The status change/interrupt request is made at the beginning of scan line zero of the split screen character row.

## Programmable Video Timing Controller (PVTC)

SCN2672

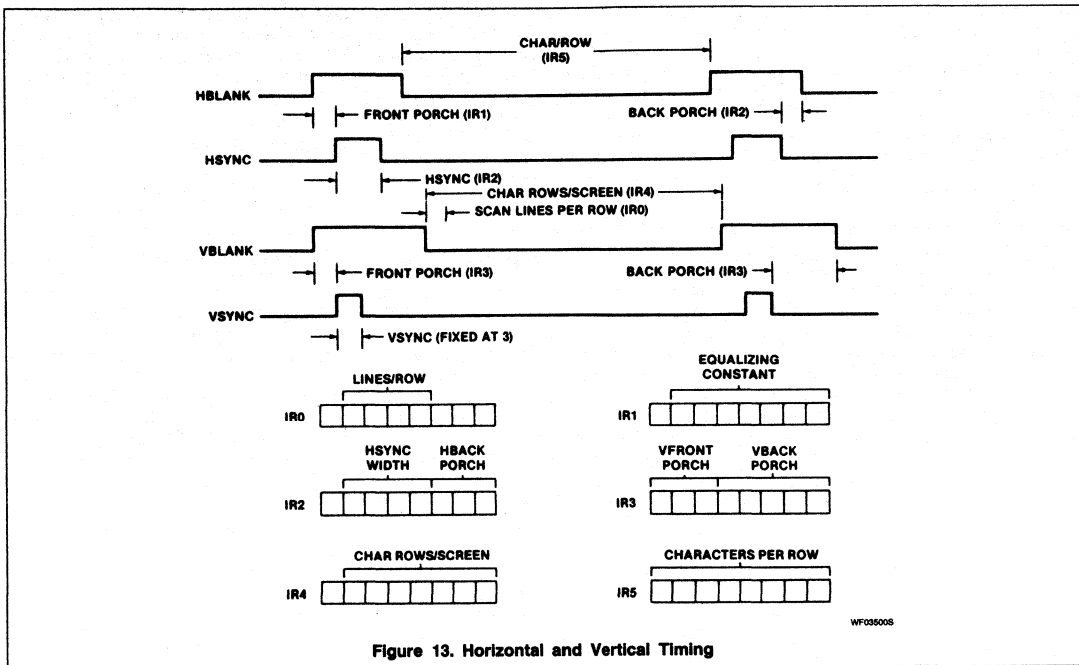

Figure 13. Horizontal and Vertical Timing

**Timing Considerations**

Normally, the contents of the initialization registers are not changed during operation. However, this may be necessary to implement special display features such as multiple cursors, smooth scrolling, horizontal scrolling, and double height character rows. Table 3 describes timing details for these registers which should be considered when implementing these features.

**Display Control Registers**

There are nine registers in this group, each with an individual address. Their formats are illustrated in Table 4. The command register is used to invoke one of 16 possible PVTC commands as described in the COMMANDS section of this data sheet. The remaining registers in the group store address values which specify the cursor and buffer pointer locations, the location of the first character to be displayed on the screen, and the location of a light pen 'hit'. With the exception of the light pen register, the user initializes these registers after powering on the system and changes their values to control the data which is displayed.

**Screen Start Registers**

The screen start registers contain the address of the first character of the first row (upper left corner of the active display). At the beginning of the first scan line of the first row,

Table 3. Timing Considerations

PARAMETER	TIMING CONSIDERATIONS
First line of cursor Last line of cursor Light pen line Underline	These parameters must be established at a minimum of two character times prior to their occurrence.
Double height characters	Set/reset during the character row prior to the affected row.
Cursor blink Cursor blink rate Character blank rate	New values become effective within one field after values are changed
Split screen interrupt row	Change anytime prior to line zero of desired row
Character rows per screen	Change only during vertical blanking period
Vertical front porch	Change prior to first line of $V_{FP}$
Vertical back porch	Change prior to fourth line after $V_{SYNC}$
Screen start register	Change prior to the horizontal blanking interval of the last line of character row prior to the affected row.

this address is transferred to the row start register (RSR) and into the memory address counter (MAC). The counter is then advanced sequentially at the character rate the number of times programmed into the active characters per row register (IRS), thus reaching the address of the last character of the row plus

one. At the beginning of each subsequent scan line of the first row, the MAC is reloaded from the RSR and the above sequence is repeated. At the end of the last scan line of the first row, the contents of the MAC are loaded into the RSR to serve as the starting memory address for the second character

# Programmable Video Timing Controller (PVTC)

SCN2672

row. This process is repeated for the programmed number of rows per screen. Thus, the data in the display memory is displayed sequentially starting from the address contained in the screen start register. After the ensuing vertical retrace interval the contents of the screen registers are reloaded into the RSR and MAC and the process is repeated.

The sequential operation described above will be modified upon the occurrence of either of two events. First, if during the incrementing of the memory address counter the 'display buffer last address' (IR9[7:4]) is reached, the MAC will be loaded from the 'display buffer first address' register (IR9[3:0], IR8[7:0]), at the next character clock. Sequential operation will then resume starting from this address. This wraparound operation allows portions of the display buffer to be used for purposes other than storage of displayable data and is completely automatic without any CPU intervention (see Figure 14a).

Second, the sequential row to row addressing can also be modified under CPU control. If the contents of the screen start register (upper, lower, or both) are changed during any character row (say row 'n'), the starting address of the next character row (row 'n + 1') will be the new value of the screen start register and addressing will continue sequentially from there. This allows features such as split screen operation, partial scroll, or status line display to be implemented. The split screen interrupt feature of the PVTC is useful in controlling this type of operation. Note that in order to obtain the correct screen display, the screen start register must be reloaded with the original value prior to the end of the vertical retrace. See Figure 14b.

### Refresh Addressing

During vertical blanking the address counter operation is modified by stopping the automatic load of the contents of the RSR into the

counter, thereby allowing the address outputs to free-run. This allows dynamic memory refresh to occur during the vertical retrace interval. The refresh addressing starts at the last address displayed on the screen and increments by one for each character clock during the retrace interval. If the display buffer last address is encountered, wraparound will occur and refreshing will continue from the display buffer first address.

### Cursor Address Registers

The contents of these registers define the buffer memory address of the cursor. If enabled, the cursor output will be asserted when the memory address counter (MAC) matches the value of the cursor address registers. The cursor address registers may be read or written by the CPU or incremented via the 'increment cursor address' command. In independent buffer mode, these registers define a buffer memory address for PVTC controlled access in response to 'read/write at cursor with/without increment' commands, or the first address to be used in executing the 'write from cursor to pointer' command.

### Display Pointer Address Registers

These registers define a buffer memory address for PVTC controlled accesses in response to 'read/write at pointer' commands. They also define the last buffer memory address to be written for the 'write from cursor to pointer' command.

### Light Pen Address Registers

If the light pen input is enabled, these registers are used to store the current character address upon receipt of a light pen strobe input. Several sources of delay between the display of a character upon the screen and the receipt of a light pen hit can be expected to exist in a system environment. These delays include address pipelining in the character generation circuits, delays in the video generation circuits, and delays in the light

detection circuitry itself. These delays cause the value stored in the light pen register to differ from the actual address of the character at which the light pen hit actually was detected. Software must be used to correct this condition.

### Interrupt/Status Registers

The interrupt and status registers provide information to the CPU to allow it to interact with the PVTC to effect desired changes to implement various display operations. The interrupt register provides information on five possible interrupting conditions, as shown in Table 5. These conditions may be selectively enabled or disabled (masked) from causing interrupts by certain PVTC commands. An interrupt condition which is enabled (mask bit equal to one) will cause the INTR output to be asserted and will cause the corresponding bit in the interrupt register to be set upon occurrence of the interrupting condition. An interrupt condition which is disabled (mask bit equal to zero) has no effect on either the INTR output or the interrupt register.

The status register provides six bits of status information: the five possible interrupting conditions plus the RDFLG bit. For this register, however, the contents are not affected by the state of the mask bits.

Descriptions of each interrupt/status register bit follow. Unless otherwise indicated, a bit, once set, will remain set until reset by the CPU by issuing a 'reset interrupt/status bits' command. The bits are also reset by a 'master reset' command and upon power-up. This bit is set to a one upon a master reset.

### SR[5] — RDFLG

This bit is present in the status register only. A zero indicates that the PVTC is currently executing the previously issued command. A one indicates that the PVTC is ready to accept a new command.

**Table 4. Display Control Register Formats**

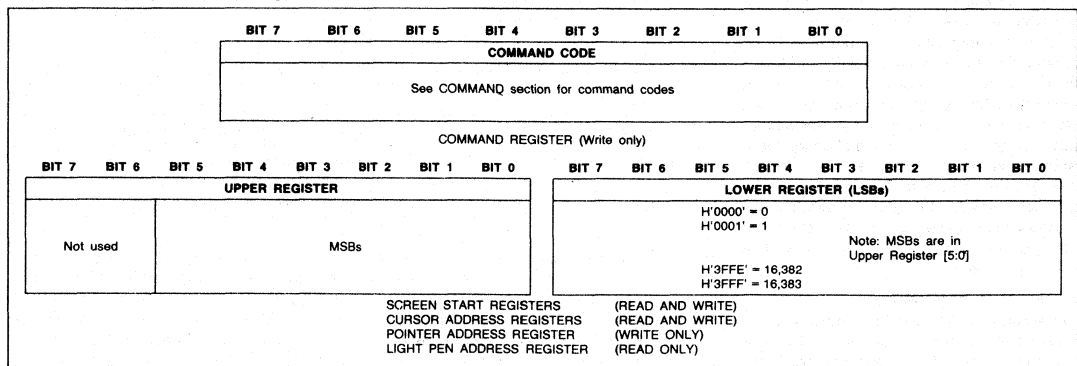



## Programmable Video Timing Controller (PVTC)

SCN2672

Table 5. Interrupt and Status Register Format

BIT 7	BIT 6	BIT 5	BIT 4	BIT 3	BIT 2	BIT 1	BIT 0
Not used always read as 0		RDFLG	VBLANK	LINE ZERO	SPLIT SCREEN	READY	LIGHT PEN
		0 = Busy 1 = Ready	0 = No 1 = Yes	0 = No 1 = Yes	0 = No 1 = Yes	0 = Busy 1 = Ready	0 = No 1 = Yes

**NOTE:**

\*Status register only. Always 0 when reading interrupt register.

**I/SR[4] — VBLANK**

Indicates the beginning of a vertical blanking interval. Is set to a one at the beginning of the first scan line of the vertical front porch.

**I/SR[3] — Line Zero**

Is set to a one at the beginning of the first scan line (line 0) of each active character row.

**I/SR[2] — Split Screen**

This bit is set when a match occurs between the current character row number and the value contained in the split screen interrupts register, IR10[6:0]. The equality condition is only checked at the beginning of line zero of each character row. This bit is reset when either of the screen start registers is loaded by the CPU.

**I/SR[1] — Ready**

Certain PVTC commands affect the display and may require the PVTC to wait for a blanking interval before enacting the command. This bit is set to one when execution of the command has been completed. No command should be invoked until the prior command is completed. This bit is set to a zero upon a master reset.

**I/SR[0] — Light Pen**

A one indicates that a light pen hit has occurred and that the contents of the light pen register have been updated. This bit will be reset when either of the light pen registers is read.

**COMMANDS**

The PVTC commands are divided into two classes: the instantaneous commands, which are executed immediately after they are invoked, and the delayed commands which may need to wait for a blanking interval prior to their execution. Command formats are shown in Table 6. The commands are asserted by performing a write operation to the command register with the appropriate bit pattern as the data byte.

**Instantaneous Commands**

The instantaneous commands are executed immediately after the trailing edge of the WR pulse during which the command is issued. These commands do not affect the state of the RDFLG or READY interrupt/status bits.

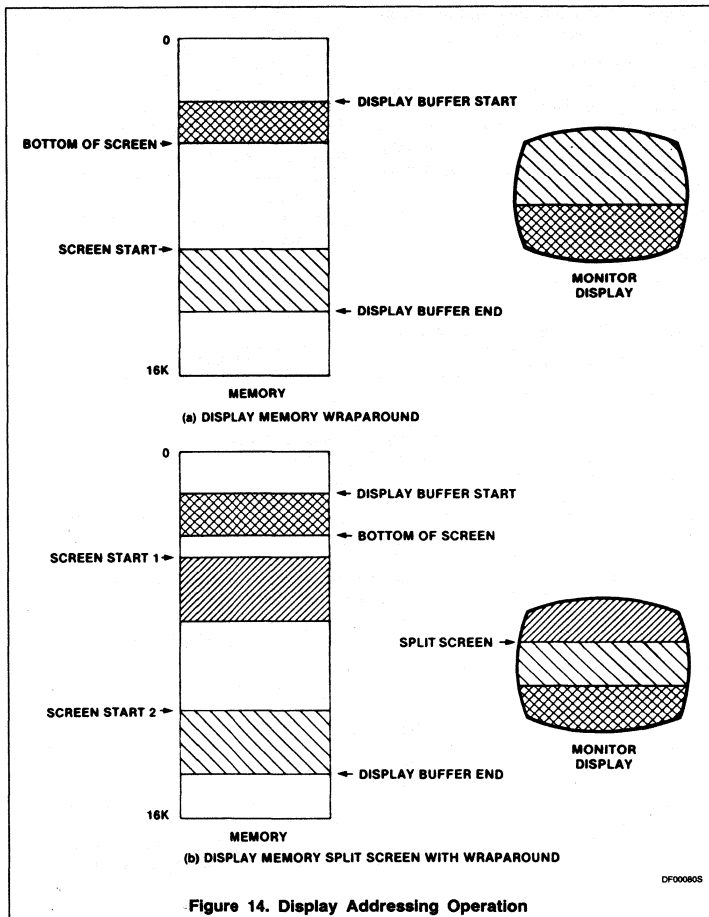

Figure 14. Display Addressing Operation

However, a command should not be invoked if the RDFLG bit is low.

**Master Reset**

This command initializes the PVTC and may be invoked at any time to return the PVTC to its initial state. Upon power-up, two successive master reset commands must be applied

to release the PVTC's internal power on circuits. In transparent and shared buffer modes, the CNTRL1 input must be high when the command is issued. The command causes the following:

1. VSYNC and HSYNC are driven low for the duration of RESET and BLANK goes

# Programmable Video Timing Controller (PVTC)

SCN2672

high. BLANK remains high until a 'display on' command is received.

- The interrupt and status bits and masks are set to zero, except for the RDFLG flag which is set to a one.
- The transparent mode, cursor off, display off, and light pen disable states are set.
- The initialization register pointer is set to address IR0.

### Load IR Address

This command is used to preset the initialization register pointer with the value 'V' defined by D3-D0. Allowable values are 0 to 10.

### Enable Light Pen

After invoking this command, receipt of a light pen strobe input will cause the light pen register to be loaded with the current buffer memory address and the corresponding interrupt and status flag to be set. Once loaded, further loads are inhibited until either one of the light pen registers are read or a reset function is performed.

### Disable Light Pen

Light pen hits will not be recognized.

### Display Off

Asserts the BLANK output. The DADD0 through DADD13 display address bus outputs may be optionally placed in the 3-State condition by setting bit 2 to a '1' when invoking the command.

### Display On

Restores normal blanking operation either at the beginning of the next field (bit 2 = 1) or at the beginning of the next scan line (bit 2 = 0). Also returns the DADD0-DADD13 drivers to their active state.

### Cursor Off

Disables cursor operation. Cursor output is placed in the low state.

### Cursor On

Enables normal cursor operation.

### Reset Interrupt/Status Bits

This command resets the designated bits in the interrupt and status registers. The bit positions correspond to the bit positions in the registers:

Bit 0 - Light pen

Bit 1 - Ready

Bit 2 - Split screen

Bit 3 - Line zero

Bit 4 - Vertical blank

### Disable Interrupts

Sets the interrupt mask to zeros for the designated conditions, thus disabling these conditions from asserting the INTR output. Bit position correspondence is as above.

### Enable Interrupts

Resets the selected interrupt and status register bits and writes the associated interrupt mask bits to a one. This enables the corresponding conditions to assert the INTR output. Bit position correspondence is as above.

### Delayed Commands

This group of commands is utilized for the independent buffer mode of operation, although the 'increment cursor' command can also be used in other modes. With the exception of the 'write from cursor to pointer' and 'increment cursor' commands, all the commands of this type will be executed immediately or will be delayed depending on when the command is invoked. If invoked during the active screen time, the command is executed at the next horizontal blanking interval. If invoked during a vertical retrace interval or a 'display off' state, the command is executed immediately.

The 'increment cursor' and 'write from cursor to pointer' commands are executed immediately after they are issued. 'Increment cursor' requires approximately three CCLK periods for completion. 'Write from cursor to pointer' asserts the BLANK output during its execution. BLANK will not be released until the beginning of the horizontal blanking interval following the last write operation. This will allow more than one 'write from cursor to pointer' command to be executed during one frame and will blank the screen for the time required to execute the command.

In all cases, the PVTC will assert the READY/RDFLG status to signify completion of the command. No other commands should be given until the current command is completed. Therefore, the READY interrupt or RDYFLG status flag should be used for handshaking control between the PVTC and CPU when using these commands.

### Read/Write at Pointer

Transfers data between the display buffer the bus interface latch using the address contained in the pointer register.

Table 6. PVTC Command Formats

D7 D6 D5 D4 D3 D2 D1 D0	COMMAND	
<b>Instantaneous Commands:</b>		
0 0 0 0 0 0 0 0	Master reset	
0 0 0 1 V V V V	Load IR pointer with value V (V = 0 to 10)	
0 0 1 d d d 1 0 <sup>1</sup>	Disable light pen	
0 0 1 d d d 1 1 <sup>2</sup>	Enable light pen	
0 0 1 d 1 N d 0 <sup>1</sup>	Display off. Float DADD bus if N = 1	
0 0 1 d 1 N d 1 <sup>2</sup>	Display on: Next field (N = 1) or scan line (N = 0)	
0 0 1 1 d d d 0 <sup>1</sup>	Cursor off	
0 0 1 1 d d d 1 <sup>2</sup>	Cursor on	
0 1 0 N N N N N	Reset interrupt/status: Bit reset where N = 1	
1 0 0 N N N N N	Disable interrupt: Disable where N = 1	
0 1 1 N N N N N	Enable interrupt: Enables interrupts and resets the corresponding interrupt/status bits where N = 1	
V L S R L B Z S D P		
<b>Delayed Commands: Hex</b>		
1 0 1 0 0 1 0 0	A4	Read at pointer address
1 0 1 0 0 0 1 0	A2	Write at pointer address
1 0 1 0 1 0 0 1	A9	Increment cursor address
1 0 1 0 1 1 0 0	AC	Read at cursor address
1 0 1 0 1 0 1 0	AA	Write at cursor address
1 0 1 0 1 1 0 1	AD	Read at cursor address and increment address
1 0 1 0 1 0 1 1	AB	Write at cursor address and increment address
1 0 1 1 1 0 1 1	BB	Write from cursor address to pointer address

### NOTES:

- Any combination of these three commands is valid.
- Any combination of these three commands is valid.
- d = Don't care.

# Programmable Video Timing Controller (PVTc)

SCN2672

## Read/Write at Cursor

Transfers data between the display buffer and the bus interface latch using the address contained in the cursor register.

## Increment Cursor

Adds one (modulo 16k) to the cursor address register.

## Read/Write at Cursor and Increment

Transfers data between the display buffer and the bus interface latch using the address contained in the cursor register and then adds one (modulo 16k) to the cursor address register.

## Write from Cursor to Pointer

Writes the data contained in the bus interface latch into the block of display memory designated by the cursor address and pointer address registers, inclusive. After completion of the command, the pointer address will be unchanged, but the cursor register contents will be equal to the pointer address.

2

## ABSOLUTE MAXIMUM RATINGS<sup>1</sup>

SYMBOL	PARAMETER	RATING	UNIT
T <sub>A</sub>	Operating ambient temperature <sup>2</sup>	0 to +70	°C
T <sub>STG</sub>	Storage temperature range	-65 to +150	°C
	All voltages with respect to ground <sup>3</sup>	-0.5 to +6	V

## DC ELECTRICAL CHARACTERISTICS T<sub>A</sub> = 0°C to +70°C, V<sub>CC</sub> = +5.0V ± 5%<sup>4, 5, 6</sup>

SYMBOL	PARAMETER	TEST CONDITIONS	LIMITS			UNIT
			Min	Typ	Max	
V <sub>IL</sub> V <sub>IH</sub>	Input low voltage Input high voltage		0.2		0.8	V V
V <sub>OL</sub> V <sub>OH</sub>	Output low voltage Output high voltage (except INTR output)	I <sub>OL</sub> = 2.4mA I <sub>OH</sub> = -200μA	2.4		0.4	V V
I <sub>IL</sub> I <sub>LL</sub>	Input leakage current Data bus 3-State leakage current	V <sub>IN</sub> = 0 to V <sub>CC</sub> V <sub>O</sub> = 0 to V <sub>CC</sub>	-10 -10		10 10	μA μA
I <sub>OD</sub> I <sub>CC</sub>	INTR open drain output leakage current Power supply current	V <sub>O</sub> = 0 to V <sub>CC</sub>			10 160	μA mA

### NOTES:

- Stresses above those listed under Absolute Maximum Rating may cause permanent damage to the device. This is a stress rating only and functional operation of the device at these or at any other condition above those in the operation section of this specification is not implied.
- For operating at elevated temperatures, the device must be derated based on +150°C maximum junction temperature.
- This product includes circuitry specifically designed for the protection of its internal devices from damaging effects of excessive static charge. Nonetheless, it is suggested that conventional precautions be taken to avoid applying voltages greater than the rated maxima.
- Parameters are valid over specified temperature range.
- All voltage measurements are referenced to ground (GND).
- Typical values are at +25°C, typical processing parameters.
- For testing, all input signals swing between 0.4V and 2.4V with a transition time of 20ns maximum. All time measurements are referenced at input voltages of 0.8V and 2V and output voltages of 0.8V and 2V as appropriate.
- Test condition for outputs: C<sub>L</sub> = 150pF.
- Timing is illustrated and specified to WR and RD inputs. Device may also be operated with CE as the 'strobing' input. In this case, all timing specifications apply referenced to falling and rising edges of CE.
- This specification requires that the CE input be negated (high) between read and/or write cycles.
- BCE, WDB, and RDB delays track each other within 10ns. Also, these output delays will tend to follow direction (min/max) of DADD0 - 13 delays.
- These values were measured with a capacitance load of 150pF. To adjust the output delay, use the following correction factor: 50pF ≤ C<sub>L</sub> < 150pF: -0.15ns/pF.

## Programmable Video Timing Controller (PVTC)

SCN2672

AC ELECTRICAL CHARACTERISTICS  $T_A = 0$  to  $+70^\circ\text{C}$ ,  $V_{CC} = +5.0\text{V} \pm 5\%$ <sup>4, 5, 6, 7, 8</sup>

SYMBOL	PARAMETER	TEST CONDITIONS	LIMITS				UNIT
			2.7MHz		4.0MHz		
			Min	Max	Min	Max	
<b>Bus timing (Figure 15)<sup>9</sup></b>							
$t_{AS}$	A0 - A2 setup time to $\overline{WR}, \overline{RD}$ low		30		30		ns
$t_{AH}$	A0 - A2 hold time from $\overline{WR}, \overline{RD}$ high		0		0		ns
$t_{CS}$	$\overline{CE}$ setup time to $\overline{WR}, \overline{RD}$ low		0		0		ns
$t_{CH}$	$\overline{CE}$ hold time from $\overline{WR}, \overline{RD}$ high		0		0		ns
$t_{RW}$	$\overline{WR}, \overline{RD}$ pulse width		250		250		ns
$t_{DD}$	Data valid after $\overline{RD}$ low			200		200	ns
$t_{DF}$	Data bus floating after $\overline{RD}$ high			100		100	ns
$t_{DS}$	Data setup time to $\overline{WR}$ high		150		150		ns
$t_{DH}$	Data hold time from $\overline{WR}$ high		10		5		ns
$t_{CC}$	High time from $\overline{CE}$ to $\overline{CE}$ <sup>10</sup>						
	Consecutive commands		600		600		ns
	Other accesses		300		300		ns
<b>CCLK timing (Figures 16 and 17)</b>							
$t_{CCP}$	$\overline{CCLK}$ period		370		250		ns
$t_{CCH}$	$\overline{CCLK}$ high time		125		100		ns
$t_{CCL}$	$\overline{CCLK}$ low time		125		100		ns
	Output delay from $\overline{CCLK}$ edge <sup>12</sup>						ns
$t_{CCD1}$	DADD0-13, MBC		40	175	40	150	ns
$t_{CCD2}$	BLANK, HSYNC, VSYNC/CSYNC, CURSOR, BEXT, BREQ, BACK, BCE, WDB, RDB <sup>11</sup>		40	225	40	200	ns
<b>Other timings (Figures 17 and 18)</b>							
$t_{RDL}$	READY/RDFLG low from $\overline{WR}$ high <sup>9</sup>			$t_{CCP} + 30$		$t_{CCP} + 30$	ns
$t_{BAK}$	BACK high from $\overline{PBREQ}$ low			225		200	ns
$t_{BEXT}$	BEXT high from $\overline{PBREQ}$ high			225		200	ns
$t_{LPS}$	Light pen strobe setup time to $\overline{CCLK}$ low		120		120		ns
$t_{LPH}$	Light pen strobe hold time from $\overline{CCLK}$ low		-10		-10		ns
$t_{IRL}$	$\overline{INTR}$ low from $\overline{CCLK}$ low			225		200	ns
$t_{IRH}$	$\overline{INTR}$ high from $\overline{WR}, \overline{RD}$ high <sup>9</sup>			600		600	ns

Programmable Video Timing Controller (PVTC)

SCN2672

2

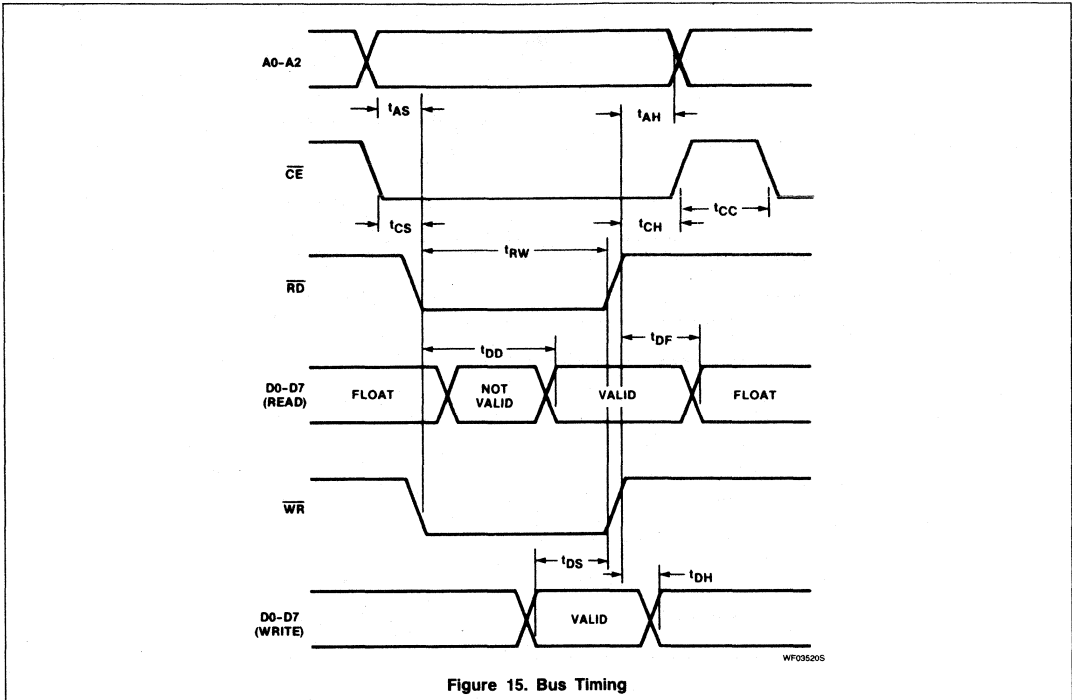

Figure 15. Bus Timing

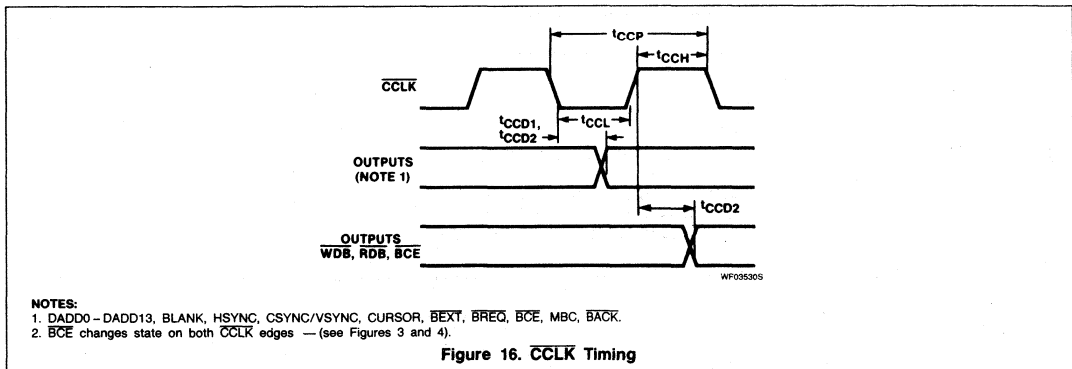

Figure 16. CCLK Timing

NOTES:

1. DADD0 - DADD13, BLANK, HSYNC, CSYNC/VSYNC, CURSOR, BEXT, BREQ, BCE, MBC, BACK.
2. BCE changes state on both CCLK edges — (see Figures 3 and 4).

Programmable Video Timing Controller (PVTC)

SCN2672

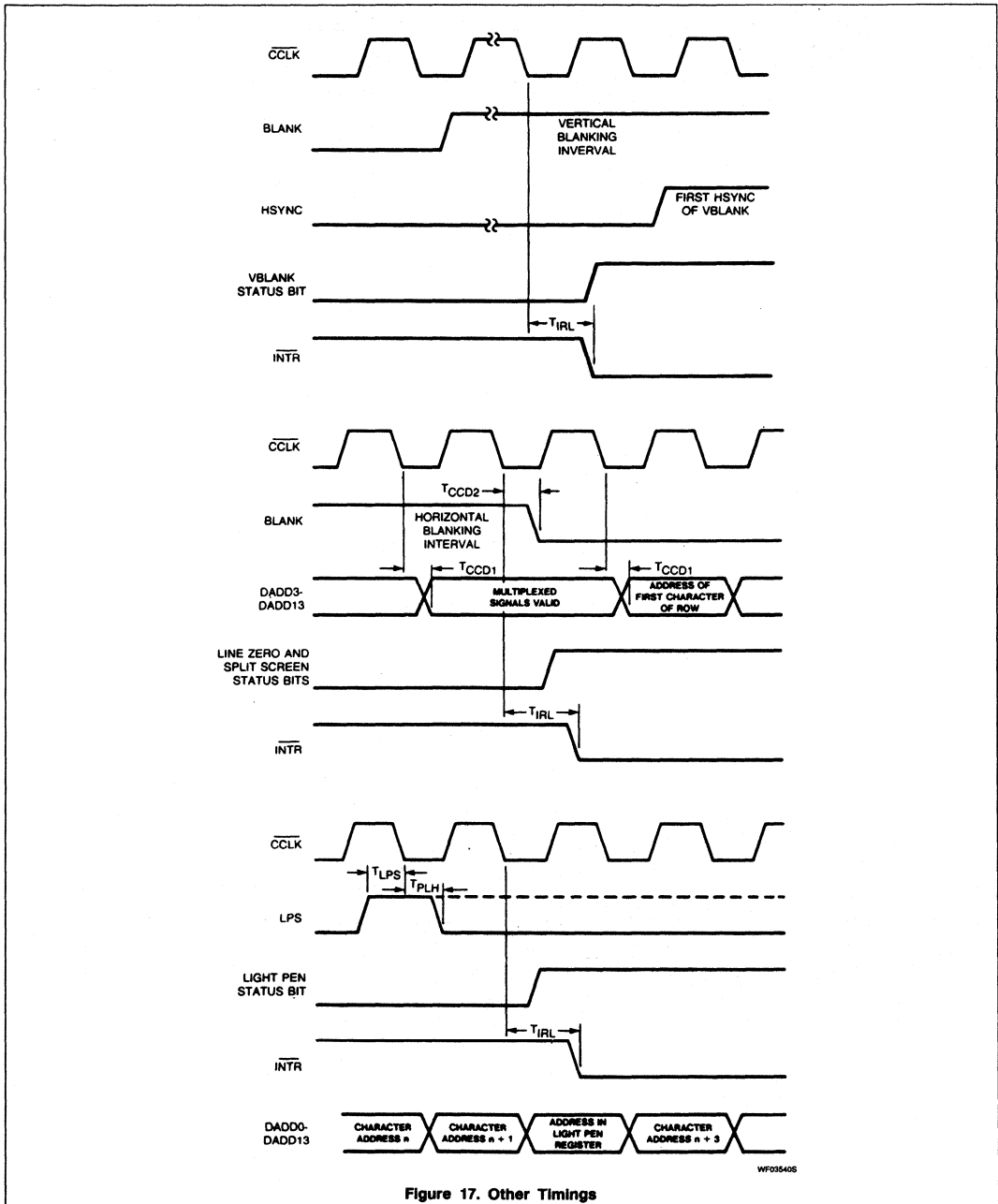

Figure 17. Other Timings

# Programmable Video Timing Controller (PVTC)

# SCN2672

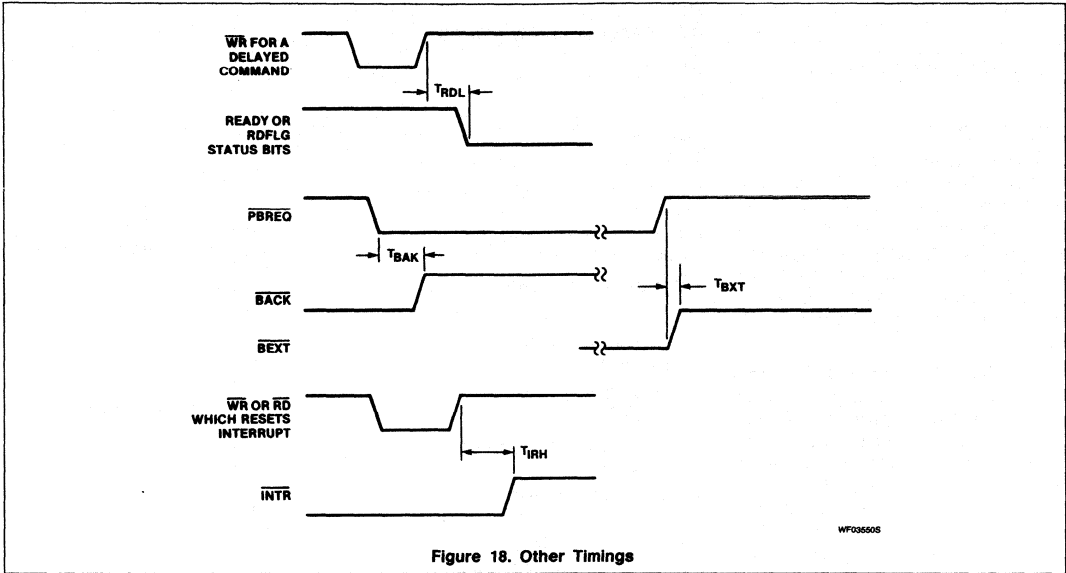
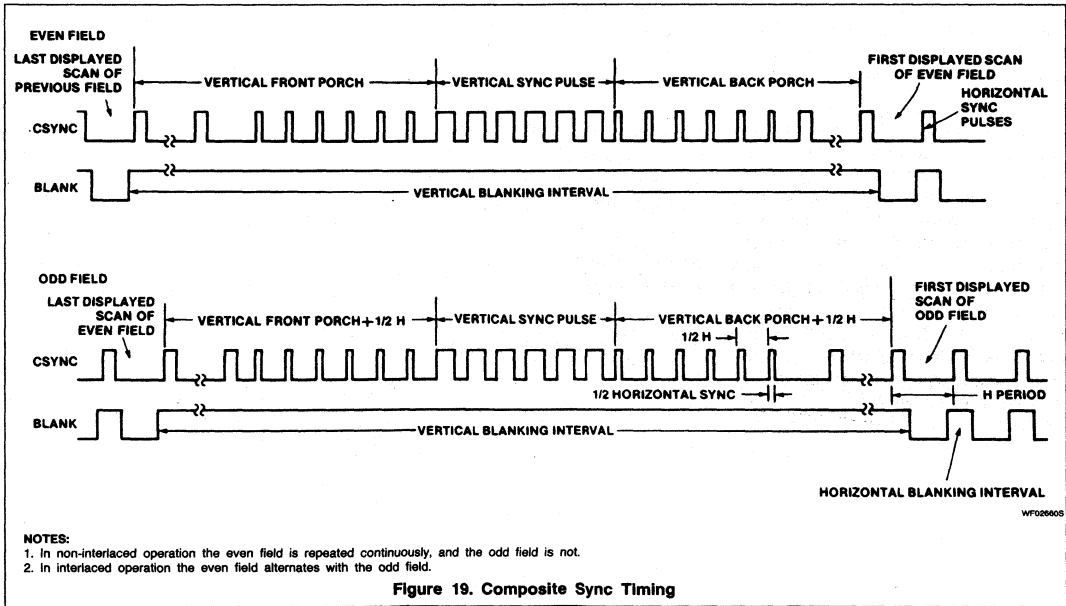

Figure 18. Other Timings



- NOTES:
1. In non-interlaced operation the even field is repeated continuously, and the odd field is not.
  2. In interlaced operation the even field alternates with the odd field.

Figure 19. Composite Sync Timing

# SCB2673

## Video Attributes Controller (VAC)

Product Specification

### Microprocessor Products

#### DESCRIPTION

The Signetics 2673A and 2673B Video Attributes Controllers (VAC) are bipolar LSI devices designed for CRT terminals and display systems that employ raster scan techniques. Each contains a high-speed video shift register, field and character attributes logic, attribute latch, cursor format logic and half-dot shift control.

The VAC provides control of visual attributes on a field or character-by-character. Internal logic preserves field attribute data from character row to character row so that an attribute byte is not required at the beginning of each row. The 2673B provides for reverse video, blank (non-display), blink, underline and highlight attributes and a graphics mode attribute to work in conjunction with the Signetics 2670 Display Character and Graphics Generator (DCGG). The 2673A substitutes a light pen (strike-through) attribute for the graphics attribute.

The horizontal dot frequency is the basic timing input to the VAC. Internally, this clock is divided down to provide a character clock output for system synchronization. Up to ten bits of video dot data are parallel loaded into the video shift register on each character boundary. The video data is shifted out on three outputs at the dot frequency. On the VIDEO output, the data is presented as a three level signal representing low, medium and high intensities. The three intensities are also encoded on two TTL compatible video outputs. Light or dark screen background can be selected.

#### FEATURES

- 18 and 25MHz video dot rates
- Three-level current-driven video output
- Three level-encoded TTL video outputs
- Character/field attribute logic:
  - Reverse video
  - Character blank
  - Character blink
  - Underline
  - Highlight
  - Light pen strike-through or graphics control
- Field attributes extend from row to row
- Light or dark field
- Cursor reverse video logic
- Up to 10 dots per character
- Composite blanking for light field retrace
- Optional field graphics control output
- High-speed bipolar design
- TTL compatible
- Compatible with Signetics' 2672 PVTC and 2670 DCGG

#### APPLICATIONS

- CRT terminals
- Word processing systems
- Small business computers

#### PIN CONFIGURATION

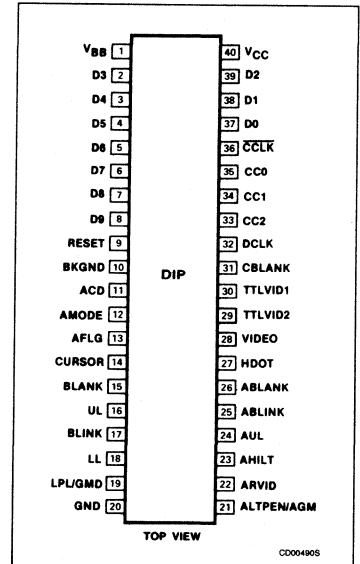



## Video Attributes Controller (VAC)

SCB2673

2

## ORDERING INFORMATION

PACKAGES	$V_{CC} = +5V \pm 5\%$ , $T_A = 0^\circ C$ to $+70^\circ C$			
	Graphics Attribute		Light Pen Attribute	
	25MHz	18MHz	25MHz	18MHz
Ceramic DIP	SCB2673BC5I40	SCB2673BC8I40	SCB2673AC5I40	SCB2673AC8I40
Plastic DIP	SCB2673BC5N40	SCB2673BC8N40	SCB2673AC5N40	SCB2673AC8N40

## BLOCK DIAGRAM

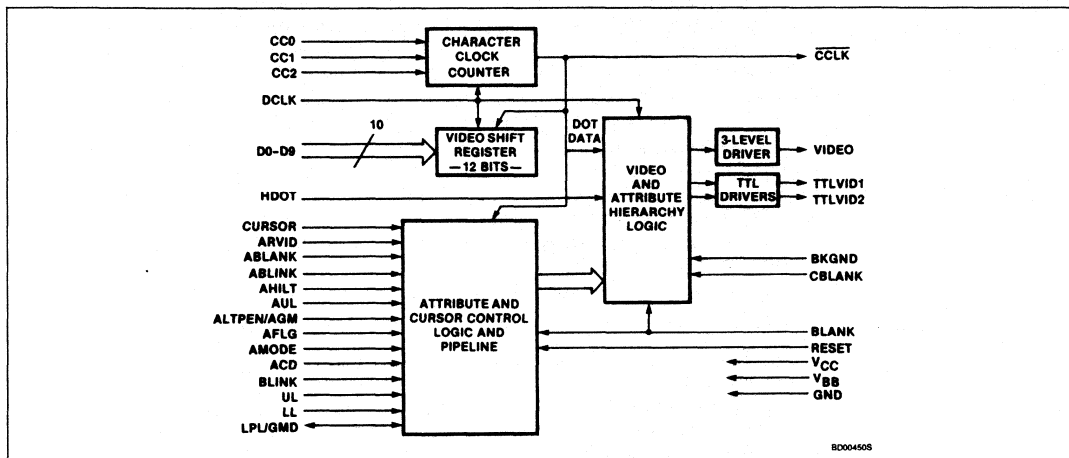

## PIN DESCRIPTION

MNEMONIC	PIN NO.	TYPE	NAME AND FUNCTION
	DIP		
DCLK	32	I	<b>Dot Clock:</b> Dot frequency input. Video shift output rate.
CCLK	36	O	<b>Character Clock:</b> A submultiple of DCLK. The frequency ranges from one sixth to one twelfth of DCLK, as determined by the state of the CC0-CC2 inputs.
CC2-CC0	33-35	I	<b>Character Clock Control:</b> The logic state on these three static inputs determine the internal divide factor for the CCLK output rate. Character clock rates of 6 through 12 dots per character may be specified.
D0-D9	37-39, 2-8	I	<b>Dot Data Input:</b> These are parallel inputs corresponding to the character graphic symbol dot data for a given scan line. These inputs are strobed into the video shift register on the falling edge of each character clock.
HDOT	27	I	<b>Half-Dot Shift:</b> When this input is high, the serial video output is delayed by one half-dot time. This input is latched on the falling edge of each character clock.
CURSOR	14	I	<b>Cursor Timing:</b> This input provides the timing for the cursor video. When high, effectively reverses the intensities of the video and attributes. Cursor position, shape, and blink rate are controlled by this input.
BKGND	10	I	<b>Background Intensity:</b> Specifies light or dark video during BLANK and character fields. Affects the intensities of all attributes.
BLANK	15	I	<b>Screen Blank:</b> When high, this input forces the video outputs to the level specified by the BKGND input (either high or low intensity). Not effective when CBLANK is high.

## Video Attributes Controller (VAC)

SCB2673

## PIN DESCRIPTION (Continued)

MNEMONIC	PIN NO.	TYPE	NAME AND FUNCTION
	DIP		
CBLANK	31	I	<b>Composite Blank:</b> Used with the TTL video outputs only. When high, this input forces the video outputs to a low intensity state for retrace blanking. When BKGND input is low, or when using video outputs, this input may be tied low.
ARVID	22	I	<b>Reverse Video Attribute:</b> The intensity of the associated character or field video is reversed. All other attributes are effectively reversed.
AHILT	23	I	<b>Highlight Attribute:</b> All dot video (including underline) of the associated character or field is highlighted with respect to the BKGND input and the reverse video attribute.
ABLANK	26	I	<b>Blank Attribute:</b> Generates a blank space in the associated character or field. The blank space intensity is determined by the BKGND input, the reverse video attribute, and the CURSOR input.
ABLINK	25	I	<b>Blink Attribute:</b> The associated character or field video is driven to the intensity determined by BKGND and the reverse video attribute when the BLINK input is high.
AUL	24	I	<b>Underline Attribute:</b> Specifies a line to be displayed on the character or field. The line is specified by the UL input. All other attributes apply to the underline video.
ALTPEN/ AGM	21	I	<b>Light Pen Attribute (2673A):</b> Specifies a highlighted line to be displayed on the character or field. The line is specified by the LPL input.
		I	<b>Attribute Graphics Mode (2673B):</b> This input is latched and synchronized to provide a field GMD output for the 2670 DCGG.
AMODE	12	I	<b>Attribute Mode:</b> Specifies character (AMODE = 0) or field (AMODE = 1) attributes mode.
AFLG	13	I	<b>Attributes Flag:</b> The VAC samples and latches the attributes inputs when this input is high. If field attributes are specified (AMODE = 1), the attributes are double buffered on a row basis. Thus, each scan line of every character row will start with the attributes that were valid at the end of the previous row.
ACD	11	I	<b>Attributes Control Display:</b> In field attributes mode (AMODE = 1), if ACD = 0, the first character in each new attribute field (the attribute control character) will be suppressed and only the attributes will be displayed. If ACD = 1, the first character and the attributes are displayed. This input has no effect in character mode (AMODE = 0).
BLINK	17	I	<b>Blink:</b> This input is sampled on the falling edge of BLANK to provide the blink rate for the character blink attribute. It should be a submultiple of the frame rate.
UL	16	I	<b>Underline:</b> Indicates the scan line(s) for the underline attribute. Latched on the falling edge of BLANK.
LPL/GMD	19	I	<b>Light Pen Line (2673A):</b> Indicates the scan line(s) for the light pen strike-through attribute. Latched on the falling edge of BLANK.
		O	<b>Graphics Mode (2673B):</b> This output provides a synchronized, latched, field graphics mode corresponding to the AGM input. This output can be used to control the GM input on the 2670 DCGG.
LL	18	I	<b>Last Line:</b> Indicates the last scan line of each character row. Used internally to extend field attributes across row boundaries. Latched on the falling edge of BLANK. This input has no effect in character mode (AMODE = 0).
VIDEO	28	O	<b>Video:</b> A three-level serial video output which corresponds to the composite dot pattern of characters, attributes and cursor.
TTLVID1	30	O	<b>TTL Video 1:</b> This output corresponds to the serial, non-highlighted video dot pattern.
TTLVID2	29	O	<b>TTL Video 2:</b> This output corresponds to the highlighted serial video dot pattern. Should be used with TTLVID1 to decode a composite video of three intensities.
RESET	9	I	<b>Manual Reset:</b> This active high input initializes the internal logic and resets the attribute latches.
V <sub>CC</sub>	40	I	<b>Power Supply:</b> +5V ±5%
V <sub>BB</sub>	1	I	<b>Bias Supply:</b> See Figure 13.
GND	20	I	<b>Ground:</b> 0V reference

## Video Attributes Controller (VAC)

SCB2673

**FUNCTIONAL DESCRIPTION**

The VAC consists of four major sections (see block diagram). The high-speed dot clock input is divided internally to provide a character clock for system timing. The parallel dot data is loaded into the video shift register on each character boundary and shifted into the video logic block at the dot rate. The six attribute inputs are latched internally and combined with the serial dot data to provide a three level video source for the monitor.

A separate BLANK input defines the active screen area. When BLANK = 0, the video levels are derived internally by the combinations of dot data, attributes, cursor, and the state of the BKGND input. Either black or white background can be selected. Symbols (dot data) are normally gray and can be highlighted to white or black as shown in Figure 1.

During the inactive screen area (BLANK = 1), the video level produced by the TTL outputs is either white (BKGND = 1) or black (BKGND = 0). A separate composite blank (CBLANK) input is provided to suppress raster retrace video when white background is specified. During the inactive screen area (BLANK = 1), the video level produced by the VIDEO output is either black (BKGND = 1) or white (BKGND = 0).

For the latter case, raster retrace video suppression is accomplished by raising the BKGND input during horizontal and vertical retrace intervals. For black background, tie BKGND high. Tie CBLANK input low for both cases.

Since BLANK is delayed by 3 CCLKs internally, CBLANK must be sync'ed with the internal BLANK signal to avoid active scan data from being suppressed. A CBLANK transition must occur at least 15ns before the rising edge of DCLK in order to be latched into the 2673 (see Figure 8).

**Table 1. Clock Control Inputs**

CC2	CC1	CC0	CCLK	
			Dots/Character	Duty Cycle*
0	0	0	6	3/3
0	0	1	6	3/3
0	1	0	7	4/3
0	1	1	8	4/4
1	0	0	9	5/4
1	0	1	10	5/5
1	1	0	11	6/5
1	1	1	12	6/6

NOTE:

\* High/low

**Character Clock Counter**

The character clock counter divides the frequency on the DCLK input to generate the character clock (CCLK). The divide factor is specified by the clock control inputs (CC0 - CC2) as shown in Table 1.

**Video Shift Register**

On each character boundary, the parallel data (D0 - D9) is loaded into the video shift register. The data is shifted out least significant bit first (D0) by the DCLK. If 11 or 12 dots/character are specified (CC2 - CC0 = 110 or 111), a 0 (blank dot) is always shifted out before D0. For 12 dots/character, a 0 is also shifted out after D9. The serial dot data is shifted into the video logic where it is combined with the cursor and attributes to encode three levels of video.

**Attribute and Cursor Control**

The VAC visual attributes capabilities include: reverse video, character blank, blink, underline, highlight, and light pen strike-through. The six attributes and the three attribute control inputs (AMODE, AFLG, and ACD) are clocked into the VAC on the falling edge of CCLK. If AFLG is high, the attributes are latched internally and are effective for either one character time (AMODE = 0) or until another set of attributes is latched (AMODE = 1). The attributes set is double

buffered on a row-by-row basis internally. Using this technique, field attributes can extend across character row boundaries, thereby eliminating the necessity of starting each row with an attribute set.

When field attribute mode is selected, (AMODE = 1), the VAC will accommodate two attribute storage configurations. In one configuration, the attribute control data is stored in the refresh RAM, taking the place of the first character code in the field to be affected. For this mode, the ACD input is tied low and blank characters will be displayed in the screen positions occupied by the attribute data (see Figure 11). In the second configuration, (ACD = 1), the character codes and attribute data are presented to the VAC in parallel. In this mode, dot data is displayed at each character position (see Figure 12).

The CURSOR and the attribute input signals are pipelined internally to allow for system propagations (one CCLK for refresh RAM, one CCLK for dot generator). The attribute timing signals BLINK, UL, LPL and LL are clocked into the VAC at the beginning of each scan line by the falling edge of the BLANK input. Thus, these signals must be in their proper state at the falling edge of BLANK preceding the scan line at which they are to be active (see Figure 4).

## Video Attributes Controller (VAC)

SCB2673

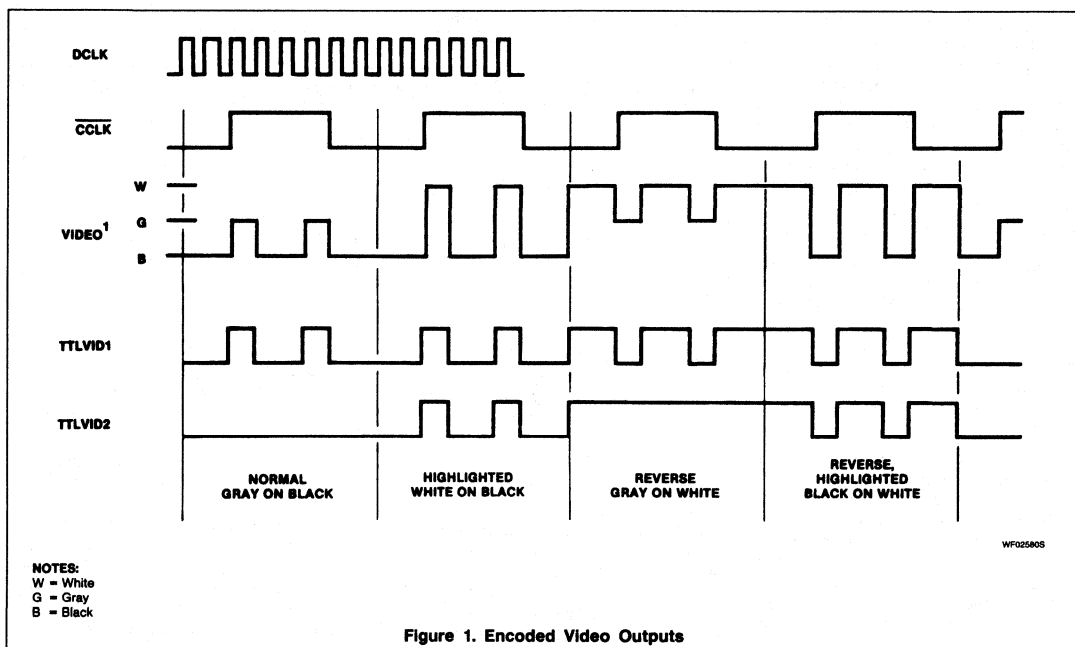

Figure 1. Encoded Video Outputs

**Video Logic**

The serial dot data and the pipelined cursor and attributes are combined to generate the three level current source on the VIDEO output. The three levels (white, gray, and black) are also encoded on the two TTL compatible outputs TTLVID1 and TTLVID2. The three levels are encoded as shown in Table 2.

The video is normally shifted out on the leading edge of the DCLK. When the HDOT input is asserted, the corresponding dot data is delayed by one-half DCLK. This half-dot shifting, when used on selected lines of character video, can be used to effect character rounding as shown in Figure 2.

**Attribute Hierarchy**

The video of each character block consists of four components as shown in Figure 3.

**Table 2. Video Output**

TTLVID2	TTLVID1	INTENSITY
0	0	Black (or CBLANK)
0	1	Gray (on black surround)
1	0	Gray (on white surround)
1	1	White

**NOTE:**

The TTLVID1 output can be used independently to generate a two-level non-highlighted video.

Symbol video is generated from the dot data inputs D0 - D9.

Underline video is enabled by the AUL attribute and is generated when the UL timing input is active. Underline and symbol video are always the same intensity.

Strike-through video is enabled by the ALTPEN attribute and is generated when the LPL timing input is active. This video is always highlighted and takes precedence over the

symbol and underline video. This feature applies to the 2673A only.

Surround video is the absence of symbol, underline and strike-through video or the presence of the non-display attributes (ABLANK or ABLINK • BLINK).

The relative intensities of the four video components are determined by the remaining attributes (AHILT, ABLANK, ABLINK, ARVID) and the BKGND and CURSOR inputs as illustrated in Table 3.

# Video Attributes Controller (VAC)

SCB2673

**2**

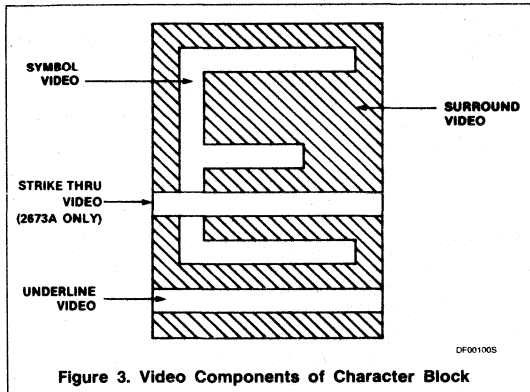
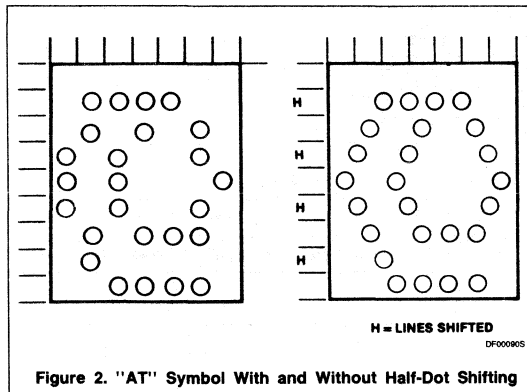

Table 3. Attributes Hierarchy

ATTRIBUTES AND CONTROL INPUTS d = Don't Care				RELATIVE VIDEO INTENSITIES W = White, B = Black, G = Gray		
BKGND <sup>5</sup>	Reverse <sup>1</sup>	Non-Display <sup>2</sup>	AHILT	Strike-Through Video <sup>3</sup>	Symbol Or Underline Video <sup>3, 4</sup>	Surround Video <sup>3</sup>
0	0	0	0	W	G	B
0	0	0	1	W	W	B
0	0	1	d	B	B	B
0	1	0	0	B	G	W
0	1	0	1	B	B	W
0	1	1	d	W	W	W
1	0	0	0	B	G	W
1	0	0	1	B	B	W
1	0	1	d	W	W	W
1	1	0	0	W	G	B
1	1	0	1	W	W	B
1	1	1	d	B	B	B

**NOTES:**

1. Reverse = ARVID • CURSOR + ARVID • CURSOR
2. Non-display = ABLANK + ABLINK • BLINK
3. See Figure 3.
4. Symbol and underline video are always the same intensity.
5. Reverse sense for VIDEO output.

## Video Attributes Controller (VAC)

SCB2673

ABSOLUTE MAXIMUM RATINGS<sup>1</sup>

SYMBOL	PARAMETER	RATING	UNIT
T <sub>A</sub>	Operating ambient temperature <sup>2</sup> range	0 to +70	°C
T <sub>STG</sub>	Storage temperature range	-65 to +150	°C
	All voltages with respect to ground	-0.5 to +6.0	V

DC ELECTRICAL CHARACTERISTICS T<sub>A</sub> = 0°C to +70°C, V<sub>CC</sub> = +5V ±5%, V<sub>BB</sub> = see Figure 14<sup>3, 4, 5</sup>

SYMBOL	PARAMETER	TEST CONDITIONS	LIMITS			UNIT
			Min	Typ	Max	
V <sub>IL</sub> V <sub>IH</sub>	Input low voltage Input high voltage		2		0.8	V V
V <sub>OL</sub> V <sub>OH</sub>	Output low voltage (except VIDEO) Output high voltage (except VIDEO)	I <sub>OL</sub> = 4mA  I <sub>OH</sub> = -400μA			0.4	V V
V <sub>B</sub> V <sub>G</sub> V <sub>W</sub>	VIDEO black level VIDEO gray level VIDEO white level	R <sub>L</sub> = 150Ω to GND R <sub>L</sub> = 150Ω to GND R <sub>L</sub> = 150Ω to GND		0 0.45 0.90		V V V
I <sub>IL</sub> I <sub>IH</sub>	Input low current Input high current	V <sub>IN</sub> = 0.4V  V <sub>IN</sub> = 2.4V			-400/ -800 <sup>6</sup> 20/40 <sup>6</sup>	μA μA
I <sub>CC</sub> I <sub>BB</sub>	V <sub>CC</sub> supply current V <sub>BB</sub> supply current	V <sub>IN</sub> = 0V, V <sub>CC</sub> = Max V <sub>BB</sub> = Max			80 120	mA mA

## NOTES:

- Stresses above those listed under Absolute Maximum Ratings may cause permanent damage to the device. This is a stress rating only and functional operation of the device at these or at any other condition above those indicated in the operation section of this specification is not implied.
- For operating at elevated temperatures, the device must be derated based on +150°C maximum junction temperature.
- Parameters are valid over operating temperature range unless otherwise specified.
- All voltage measurements are referenced to ground (V<sub>SS</sub>). All input signals swing between 0.4V and 2.4V. All time measurements are referenced at input voltages of 0.8V, 2V and at output voltages of 0.8V, 2V as appropriate.
- Typical values are at +25°C, typical supply voltages and typical processing parameters.
- For DCLK input.
- C<sub>L</sub> less than 150pF minimum could be faster.

## Video Attributes Controller (VAC)

SCB2673

**AC ELECTRICAL CHARACTERISTICS**  $T_A = 0^\circ\text{C}$  to  $+70^\circ\text{C}$ ,  $V_{CC} = +5\text{V} \pm 5\%$ ,  $V_{BB} =$  see Figure 14<sup>3, 4, 5</sup>

SYMBOL	PARAMETER	TEST CONDITIONS	LIMITS				UNIT
			25MHz Version		18MHz Version		
			Min	Max	Min	Max	
<b>Dot clock (see Figure 10)</b>							
$f_d$	Frequency (HDOT = 0) (HDOT = 1)			25 18		18 18	MHz
$t_{DH}$	High		15		22		ns
$t_{DL}$	Low		15		22		ns
<b>Setup times to CCLK (see Figures 4, 5, 6 and 10)</b>							
$t_{BS}$	BLANK		50		50		ns
$t_{SC}$	BLINK, UL, LPL, LL (ref to BLANK)		20		20		ns
$t_{SA}$	Attributes		45		55		ns
$t_{SD}$	Dot data D0 - D9		70		70		ns
$t_{SK}$	CURSOR		50		50		ns
$t_{FS}$	AFLG, AMODE		50		65		ns
$t_{SH}$	HDOT		45		55		ns
<b>Hold times from CCLK (see Figures 4, 5, 6 and 10)</b>							
$t_{HC}$	BLINK, UL, LPL, LL (ref to BLANK)		20		20		ns
$t_{HA}$	Attributes		20		20		ns
$t_{HD}$	Dot data D0 - D9		30		30		ns
$t_{HK}$	CURSOR		20		20		ns
$t_{FH}$	AFLG, AMODE		30		30		ns
$t_{HH}$	HDOT		20		20		ns
<b>Setup times to DCLK (see Figure 9)</b>							
$t_{SG}$	BKGND		15		15		ns
$t_{SB}$	CBLANK		15		15		ns
$t_{CS}$	CC0 - CC2		30		35		ns
<b>Hold times from DCLK (see Figure 9)</b>							
$t_{HG}$	BKGND		15		15		ns
$t_{HB}$	CBLANK		15		15		ns
$t_{CH}$	CC0 - CC2		20		20		ns
<b>Delay times (see Figures 6 and 7)</b>							
$t_{DGM}$	GMD from DCLK			65		65	ns
$t_{DC}$	CCLK from DCLK			65		65	ns
$t_{DV}^7$	TTLVID1 and TTLVID2 from DCLK			75		80	ns
$t_{DV}$	VIDEO from DCLK	$C_L = 150\text{pF}$		240		240	ns

2

Video Attributes Controller (VAC)

SCB2673

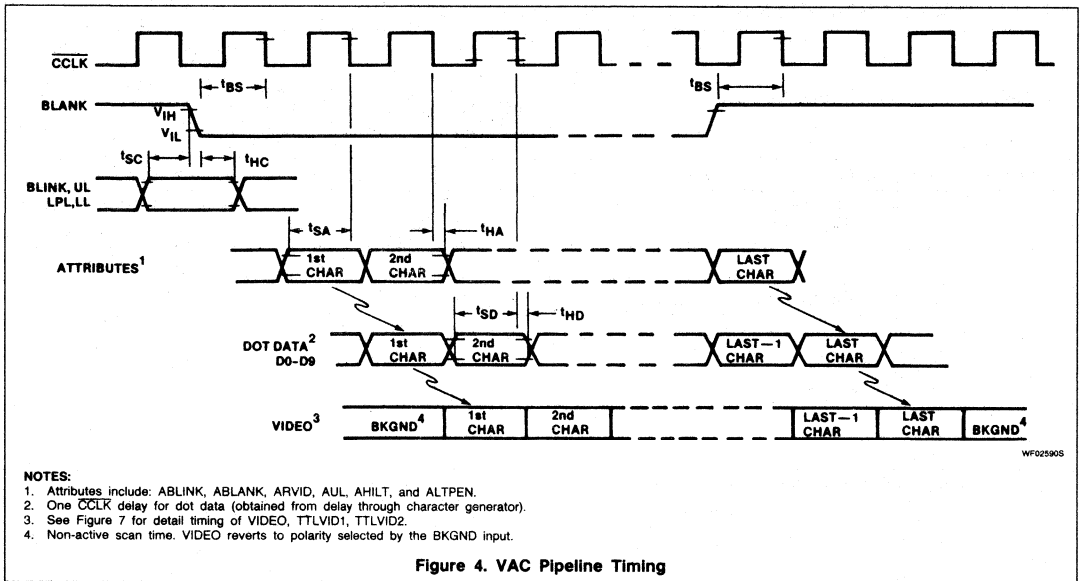

Figure 4. VAC Pipeline Timing

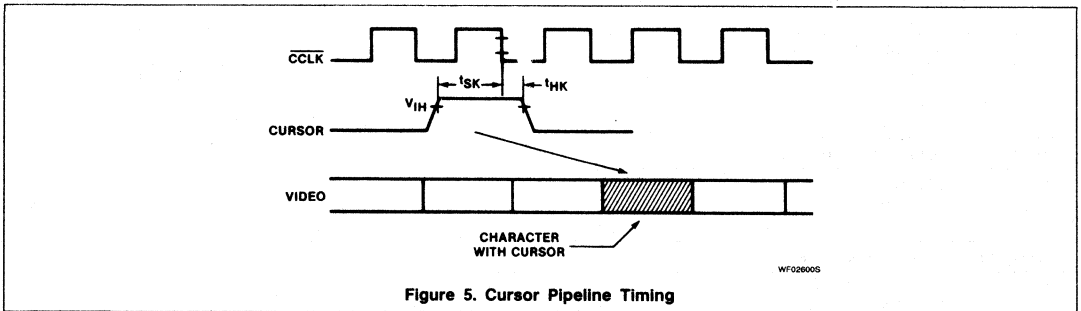

Figure 5. Cursor Pipeline Timing



# Video Attributes Controller (VAC)

SCB2673

2

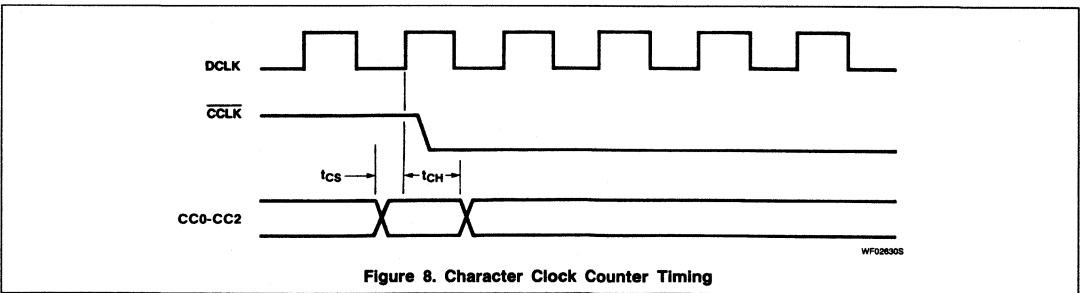
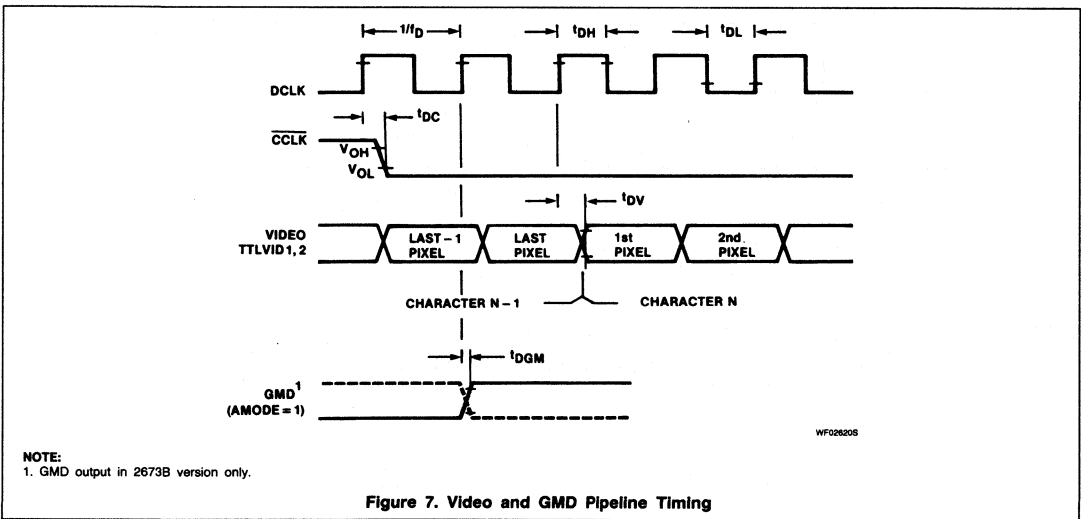
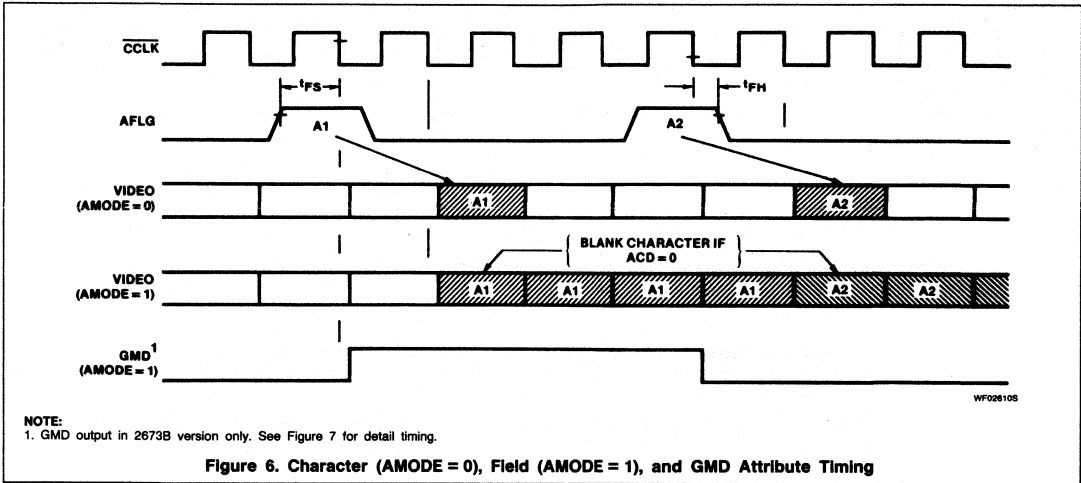

# Video Attributes Controller (VAC)

SCB2673

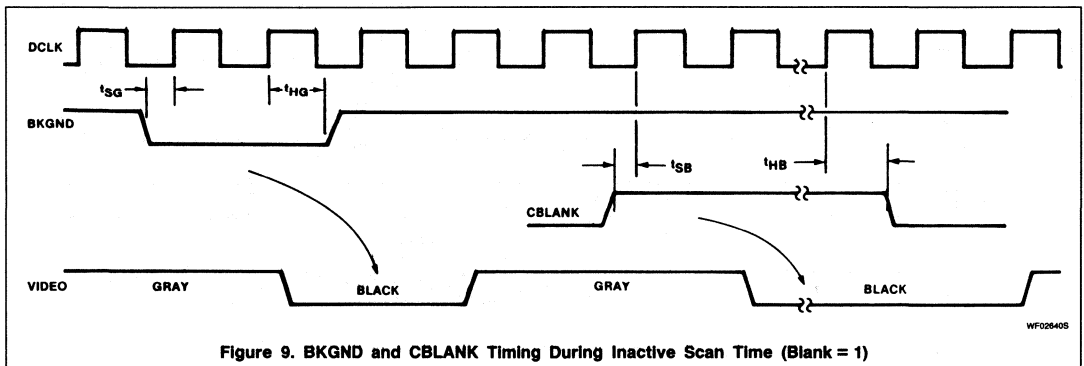
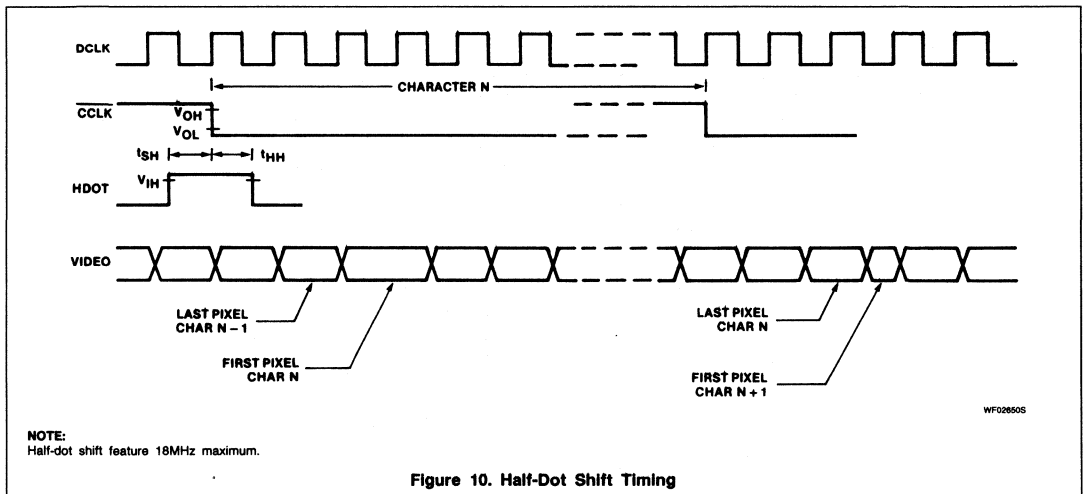

Figure 9. BKGND and CBLANK Timing During Inactive Scan Time (Blank = 1)



NOTE:  
Half-dot shift feature 18MHz maximum.

Figure 10. Half-Dot Shift Timing

# Video Attributes Controller (VAC)

# SCB2673

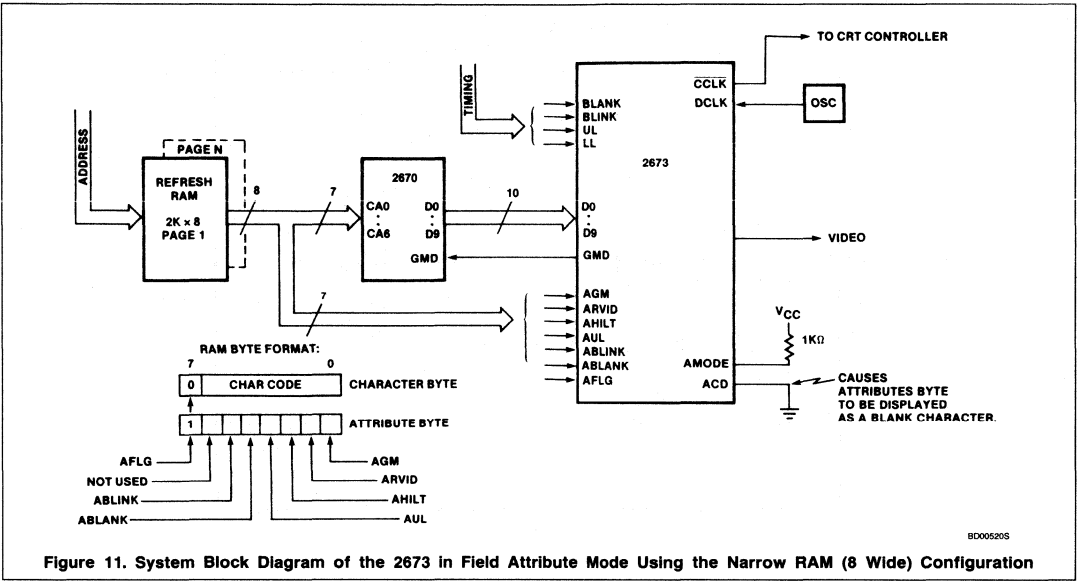

Figure 11. System Block Diagram of the 2673 in Field Attribute Mode Using the Narrow RAM (8 Wide) Configuration

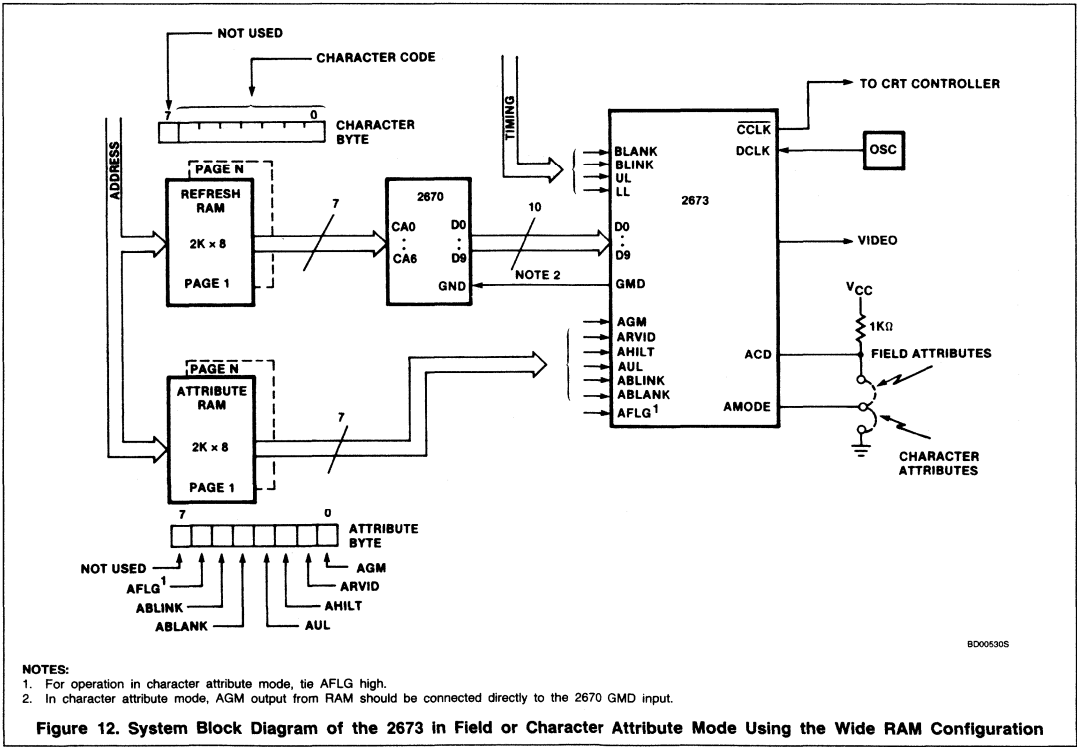

Figure 12. System Block Diagram of the 2673 in Field or Character Attribute Mode Using the Wide RAM Configuration

Video Attributes Controller (VAC)

SCB2673

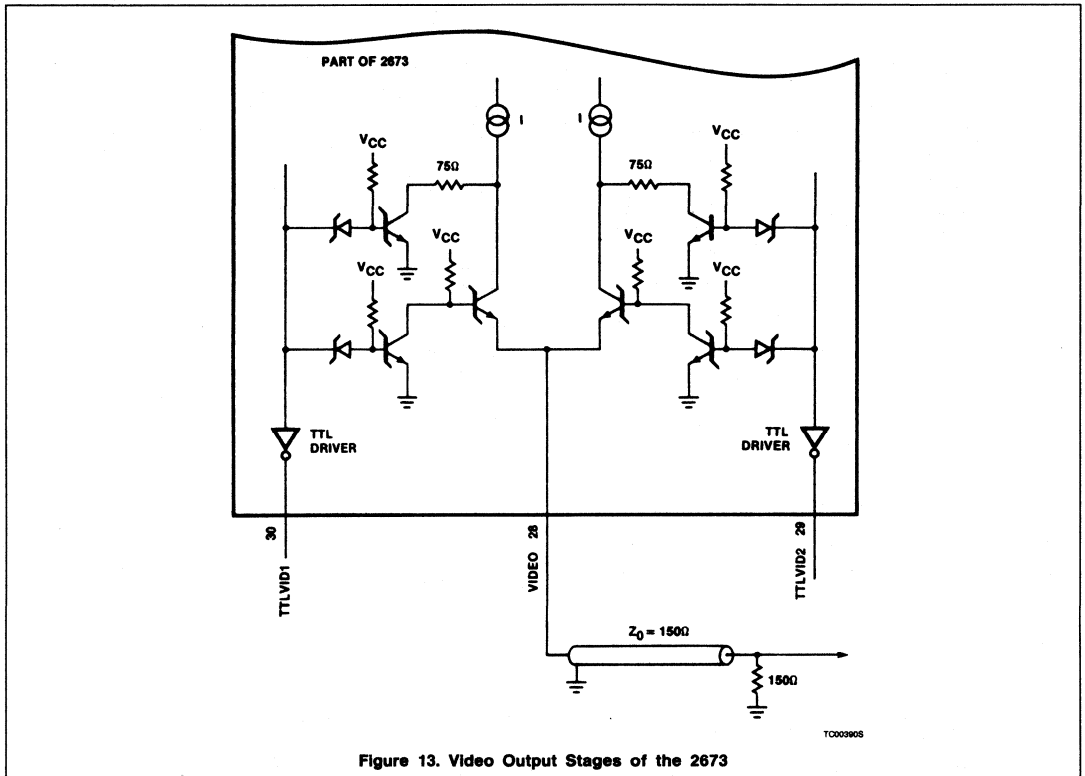

Figure 13. Video Output Stages of the 2673

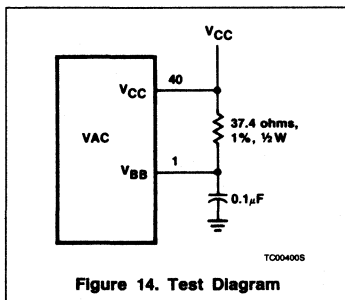

Figure 14. Test Diagram

# SCN2674

## Advanced Video Display Controller (AVDC)

Product Specification

### Microprocessor Products

#### DESCRIPTION

The Signetics SCN2674 Advanced Video Display Controller (AVDC) is a programmable device designed for use in CRT terminals and display systems that employ raster scan techniques. The AVDC generates the vertical and horizontal timing signals necessary for the display of interlaced or non-interlaced data on a CRT monitor. It provides consecutive addressing to a user-specified display buffer memory domain and controls the CPU display buffer interface for various buffer configuration modes. A variety of operating modes, display formats, and timing profiles can be implemented by programming the control registers in the AVDC.

A minimum CRT terminal system configuration consists of an AVDC, an SCN2671 Keyboard and Communication Controller (PKCC), an SCN2670 Display Character and Graphics Generator (DCGG), an SCB2675 Color/Monochrome Attributes Controller (CMAC), a single-chip microcomputer such as the 8048, a display buffer RAM, and a small amount of TTL for miscellaneous address decoding, interface, and control. Typically, the package count for a minimum system is between 15 and 20 devices; system complexity can be enhanced by upgrading the microprocessor and expanding via the system address and data buses.

#### FEATURES

- 2.7MHz and 4MHz character rates
- 1 to 256 characters per row
- 1 to 16 raster lines per character row
- 1 to 128 character rows per frame
- Bit-mapped graphics mode
- Programmable horizontal and vertical sync generators
  - RS-170 compatible sync
- Interlaced or non-interlaced operation
- Up to 64k RAM addressing for multiple page operation
- Readable, writable and incrementable cursor
  - Programmable cursor size and blink
- AC line lock
- Automatic wraparound of RAM
- Automatic split screen
- Automatic bidirectional soft scrolling
  - Programmable scan line increment
- Row table addressing mode
- Double height tops and bottoms
- Double width control output
- Selectable buffer interface modes
- Dynamic RAM refresh
- Completely TTL compatible
- Single +5V power supply
- Power-on reset circuit

#### APPLICATIONS

- CRT terminals
- Word processing systems
- Small business computers
- Home computers

#### PIN CONFIGURATIONS

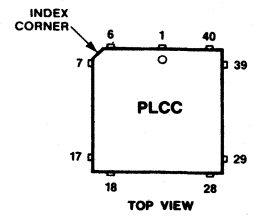
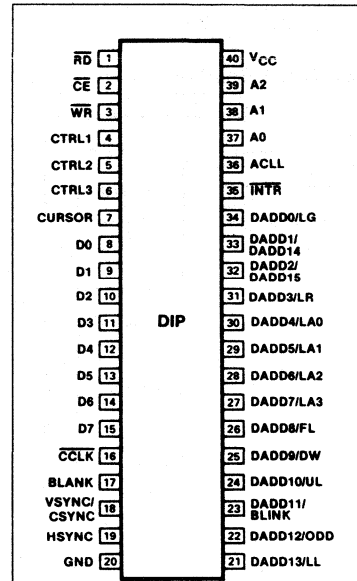

Pin	Function	Pin	Function	Pin	Function
1	NC	17	D7	31	DADD6/LA2
2	RD	18	CCLK	32	DADD5/LA1
3	CE	19	BLANK	33	DADD4/LA0
4	WR	20	VSYNC	34	NC
5	CTRL1	21	CSYNC/	35	DADD3/LR
6	CTRL2	22	HSYNC	36	DADD2/
7	CTRL3	23	GND	37	DADD15
8	CURSOR	24	NC	38	DADD14
9	D0	25	DADD13/LL	39	DADD0/LG
10	D1	26	DADD12/	40	ACL
11	D2	27	ODD	41	A0
12	NC	28	DADD11/	42	A1
13	D3	29	BLINK	43	A2
14	D4	30	DADD10/UL	44	VCC
15	D5				
16	D6				

# Advanced Video Display Controller (AVDC)

# SCN2674

## ORDERING INFORMATION

PACKAGES	$V_{CC} = +5V \pm 5\%$ , $T_A = 0^\circ C$ to $+70^\circ C$	
	4MHz	2.7MHz
Ceramic DIP	SCN2674BC4140	SCN2674BC3140
Plastic DIP	SCN2674BC4N40	SCN2674BC3N40
Plastic LCC	SCN2674BC4A44	SCN2674BC3A44

## BLOCK DIAGRAM

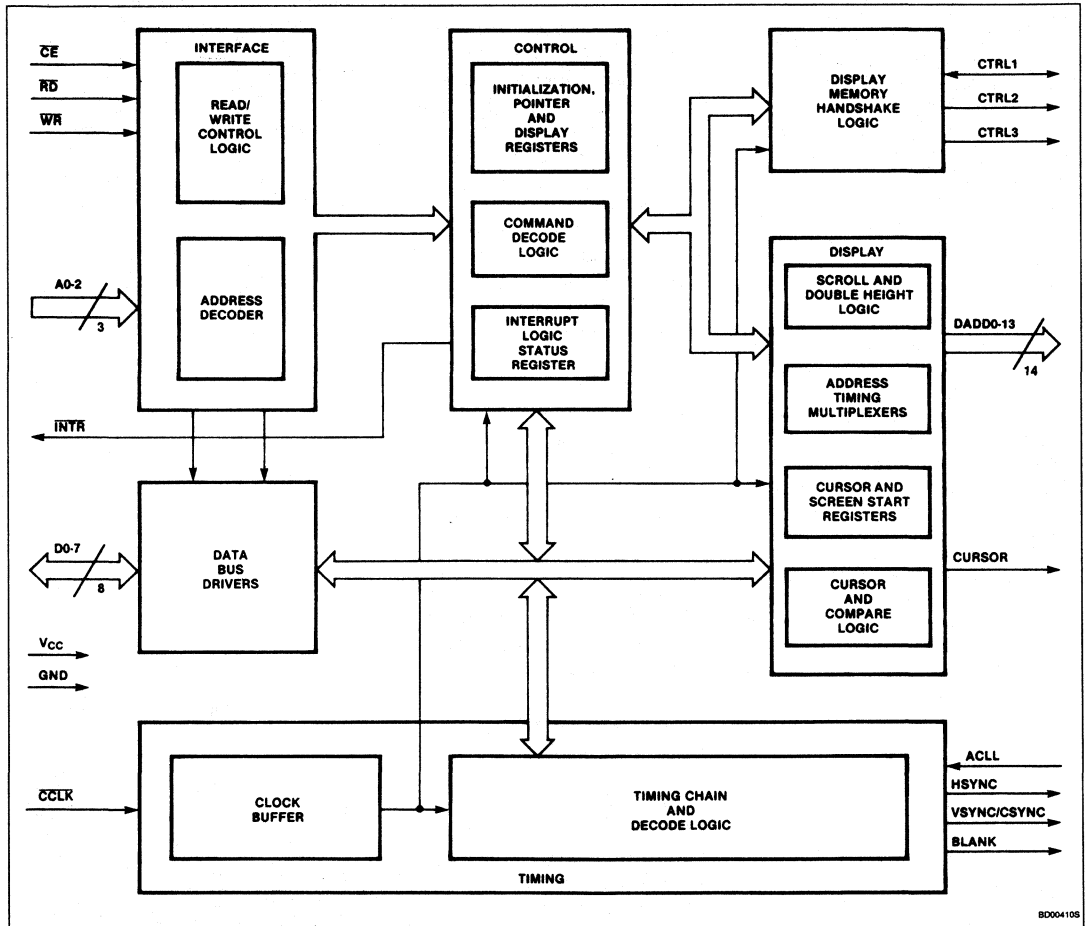

## Advanced Video Display Controller (AVDC)

SCN2674

## PIN DESCRIPTION

MNEMONIC	PIN NO.		TYPE	NAME AND FUNCTION
	DIP	PLCC		
A0 – A2	37 – 39	41 – 43	I	<b>Address Lines:</b> Used to select AVDC internal registers for read/write operations and for commands.
D0 – D7	8 – 15	9 – 11, 13 – 17	I/O	<b>8-Bit Bidirectional Three-State Data Bus:</b> Bit 0 is the LSB and bit 7 is the MSB. All data, command, and status transfers between the CPU and the AVDC take place over this bus. The direction of the transfer is controlled by the $\overline{RD}$ and $\overline{WR}$ inputs when the $\overline{CE}$ input is low. When the $\overline{CE}$ input is high, the data bus is in the 3-State condition.
$\overline{RD}$	1	2	I	<b>Read Strobe:</b> Active low input. A low on this pin while $\overline{CE}$ is low causes the contents of the register selected by A0 – A2 to be placed on the data bus. The read cycle begins on the leading (falling) edge of $\overline{RD}$ .
$\overline{WR}$	3	4	I	<b>Write Strobe:</b> Active low input. A low on this pin while $\overline{CE}$ is also low causes the contents of the data bus to be transferred to the register selected by A0 – A2. The transfer occurs on the trailing (rising) edge of $\overline{WR}$ .
$\overline{CE}$	2	3	I	<b>Chip Enable:</b> Active low input. When low, data transfers between the CPU and the AVDC are enabled on D0 – D7 as controlled by the $\overline{WR}$ , $\overline{RD}$ , and A0 – A2 inputs. When $\overline{CE}$ is high, effectively, the AVDC is isolated from the data bus and D0 – D7 are placed in the 3-State condition.
$\overline{CLK}$	16	18	I	<b>Character Clock:</b> Timing signal derived from the video dot clock which is used to synchronize the AVDC's timing functions.
HSYNC	19	21	O	<b>Horizontal Sync:</b> Active high output which provides video horizontal sync pulses. The timing parameters are programmable.
VSYNC/ CSYNC	18	20	O	<b>Vertical Sync/Composite Sync:</b> A control selects either vertical or composite sync pulses on this active high output. When CSYNC is selected, equalization pulses are included. The timing parameters are programmable.
BLANK	17	19	O	<b>Blank:</b> This active high output defines the horizontal and vertical borders of the display. Display control signals which are output on DADD0 through DADD13 are valid on the trailing edge of BLANK.
CURSOR	7	8	O	<b>Cursor Gate:</b> This output becomes active for a specified number of scan lines when the address contained in the cursor register matches the address output on DADD0 through DADD13 for displayable character addresses. The first and last lines of the cursor and a blink option are programmable. When the row table addressing mode is enabled, this output is active for a portion of the blanking interval prior to the first scan line of a character row, while the AVDC is fetching the starting address for that row.
$\overline{INTR}$	35	39	O	<b>Interrupt Request:</b> Open drain output which supplies an active low interrupt request from any of five maskable sources. This pin is inactive after a power on reset or a master reset command.
ACLL	36	40	I	<b>AC Line Lock:</b> If this input is low after the programmed vertical front porch interval, the vertical front porch will be lengthened by increments of horizontal scan line times until this input goes high. This input should be pulled high if not being used.
CTRL1	4	5	I/O	<b>Handshake Control 1:</b> In independent mode, provides an active low write data buffer ( $\overline{WDB}$ ) output which strobes data from the interface latch into the display memory. In transparent and shared modes, this is an active low processor bus request ( $\overline{PBREQ}$ ) input which indicates that the CPU desires to access the display memory.
CTRL2	5	6	O	<b>Handshake Control 2:</b> In independent mode, provides an active low read data buffer ( $\overline{RDB}$ ) output which strobes data from the display memory into the interface latch. In transparent and shared modes, this is an active low bus external enable ( $\overline{BEXT}$ ) output which indicates that the AVDC has relinquished control of the display memory (DADD0 – DADD13 are in the 3-State condition) in response to a CPU bus request. $\overline{BEXT}$ also goes low in response to a 'display off and float DADD' command. In row buffer mode, it is an active low bus request ( $\overline{BREQ}$ ) output which halts the CPU during a line DMA.

## Advanced Video Display Controller (AVDC)

SCN2674

## PIN DESCRIPTION (Continued)

MNEMONIC	PIN NO.		TYPE	NAME AND FUNCTION
	DIP	PLCC		
CTRL3	6	7	O	<b>Handshake Control 3:</b> In independent mode, provides the active low buffer chip enable ( $\overline{BCE}$ ) signal to the display memory. In transparent and shared modes, provides an active low bus acknowledge ( $\overline{BACK}$ ) output which serves as a ready signal to the CPU in response to a processor bus request. In row buffer mode, this is an active high memory bus control ( $\overline{MBC}$ ) output which configures the system for the DMA transfer of one row of character codes from system memory to the row display buffer.
DADD0 – DADD13	34-21	38 – 35, 33 – 24	O	<p><b>Display Address:</b> Used by the AVDC to address up to 16k of display memory directly, or up to 64k of memory by demultiplexing DADD14 and DADD15. These outputs are floated at various times depending on the buffer mode. Various control signals are multiplexed on DADD0 through DADD13 and are valid at the trailing edge of BLANK. These control signals are:</p> <p><b>DADD0/LG</b> <b>Line Graphics:</b> Output which denotes bit-mapped graphic mode.</p> <p><b>DADD1/DADD14</b> <b>Display Address 14:</b> Multiplexed address bit used to extend addressing to 64k.</p> <p><b>DADD2/DADD15</b> <b>Display Address 15:</b> Multiplexed address bit used to extend addressing to 64k.</p> <p><b>DADD3/LR</b> <b>Last Row:</b> Output which indicates the last active character row of each field.</p> <p><b>DADD4 – DADD7/LA0 – LA3</b> <b>Line Address:</b> Provides the number of the current scan line count for each character row.</p> <p><b>DADD8/FL</b> <b>First Line:</b> Asserted during the blanking interval just prior to the first scan line of each character row.</p> <p><b>DADD9/DW</b> <b>Double Width:</b> Output which denotes a double width character row.</p> <p><b>DADD10/UL</b> <b>Underline:</b> Asserted during the blanking interval just prior to the scan line which matches the programmed underline position (lines 0 through 15).</p> <p><b>DADD11/BLINK</b> <b>Blink Frequency:</b> Provides an output divided down from the vertical sync rate.</p> <p><b>DADD12/ODD</b> <b>Odd Field:</b> Active high signal which is asserted before each scan line of the odd field when interlace is specified. Replaces DADD4/LA0 as the least significant line address for interlaced sync and video applications.</p> <p><b>DADD13/LL</b> <b>Last Line:</b> Asserted during the blanking interval just prior to the last scan line of each character row.</p>
V <sub>CC</sub>	40	44	I	<b>Power Supply:</b> +5V power input.
GND	20	22	I	<b>Ground:</b> Signal and power ground input.

**FUNCTIONAL DESCRIPTION**

As shown in the block diagram, the AVDC contains the following major blocks:

- Data bus buffer
- Interface Logic
- Operation Control
- Timing
- Display Control
- Buffer Control

**Data Bus Buffer**

The data bus buffer provides the interface between the external and internal data buses.

It is controlled by the operation control block to allow read and write operations to take place between the controlling CPU and the AVDC.

**Interface Logic**

The interface logic contains address decoding and read and write circuits to permit communications with the microprocessor via the data bus buffer. The functions performed by the CPU read and write operations are shown in Table 1.

**Operation Control**

The operation control section decodes configuration and operation commands from the CPU and generates appropriate signals to other internal sections to control the overall device operation. It contains the timing and display registers which configure the display format and operating mode, the interrupt logic, and the status register which provides operational feedback to the CPU.

**Timing**

The timing section contains the counters and decoding logic necessary to generate the



## Advanced Video Display Controller (AVDC)

SCN2674

monitor timing outputs and to control the display format. These timing parameters are selected by programming of the initialization registers.

### Display Control

The display control section generates linear addressing for up to 16k bytes of display memory. Internal comparators limit the portion of the memory which is displayed to programmed values. Additional functions performed in this section include cursor positioning and address comparisons required for generation of timing signals, double-height tops and bottoms, smooth scrolling, and the split screen interrupts.

### Buffer Control

The buffer control section generates three signals which control the transfer of data between the CPU and the display buffer memory. Four system configurations requiring four different 'handshaking' schemes are supported. These are described below.

## SYSTEM CONFIGURATIONS

Figure 1 illustrates the block diagram of a typical display terminal using the Signetics SCN2670, SCN2671, SCN2674, and SCB2675 CRT terminal devices. In this system, the CPU examines inputs from the data communications line and the keyboard and places the data to be displayed in the display buffer memory. This buffer is typically a RAM which holds the data for a single or multiple screenload (page) or for a single character row.

The AVDC supports four common system configurations of display buffer memory: the independent, transparent, shared, and row buffer modes. The first three modes utilize a single or multiple page RAM and differ primarily in the means used to transfer display data between the RAM and the CPU. The row buffer mode makes use of a single row buffer (which can be a shift register or a small RAM) that is updated in real time to contain the appropriate display data.

The user programs bits 0 and 1 of IR0 to select the mode best suited for the system environment. The CNTRL1-3 outputs perform different functions for each mode and are named accordingly in the description of each mode.

### Independent Mode

The CPU to RAM interface configuration for this mode is illustrated in Figure 2. Transfer of data between the CPU and display memory is accomplished via a bidirectional latched port and is controlled by read data buffer (RDB), write data buffer (WDB), and buffer chip enable (BCE). This mode provides a nonconvention type of operation that does not require address multiplexers. The CPU does not

Table 1. AVDC Addressing

A2	A1	A0	READ ( $\overline{RD} = 0$ )	WRITE ( $\overline{WR} = 0$ )
0	0	0	Interrupt register	Initialization registers <sup>1</sup>
0	0	1	Status register	Command register
0	1	0	Screen start 1 lower register	Screen start 1 lower register
0	1	1	Screen start 1 upper register	Screen start 1 upper register
1	0	0	Cursor address lower register	Cursor address lower register
1	0	1	Cursor address upper register	Cursor address upper register
1	1	0	Screen start 2 lower register	Screen start 2 lower register
1	1	1	Screen start 2 upper register	Screen start 2 upper register

#### NOTE:

1. There are 15 initialization registers which are accessed sequentially via a single address. The AVDC maintains an internal pointer to these registers which is incremented after each write at this address until the last register (IR14) is accessed. The pointer then continues to point to IR14 for additional accesses. Upon a power-on or a master reset command, the internal pointer is reset to point to the first register (IR0) of the initialization register group. The internal pointer can also be preset to any register of the group via the 'load IR address pointer' command.

address the memory directly—the read or write operation is performed at the address contained in the cursor address register or the pointer address register as specified by the CPU. The AVDC enacts the data transfers during blanking intervals in order to prevent visual disturbances of the displayed data.

The CPU manages the data transfers by supplying commands to the AVDC. The commands used are:

1. Read/write at pointer address.
2. Read/write at cursor address (with optional increment of address).
3. Read/write from cursor address to pointer address.

The operational sequence for a write operation is:

1. CPU checks RDFLG status bit to assure that any delayed commands have been completed.
2. CPU loads data to be written to display memory into the interface latch.
3. CPU writes address into cursor or pointer registers.
4. CPU issues 'write at cursor with/without increment' or 'write at pointer' command.
5. AVDC generates control signals and outputs specified address to perform requested operation. Data is copied from the interface latch into the memory.
6. AVDC sets RDFLG status to indicate that the write is completed.

Similarly, a read operation proceeds as follows:

1. Steps 1 and 3 as above.
2. CPU issues 'read at cursor with/without increment' or 'read at pointer' command.
3. AVDC generates control signals and outputs specified address to perform requested operation. Data is copied from memory to the interface latch and AVDC sets RDFLG status to indicate that the read is completed.

4. CPU checks RDFLG status to see if operation is completed.
5. CPU reads data from interface latch.

Loading the same data into a block of display memory is accomplished via the 'write from cursor to pointer' command:

1. CPU checks RDFLG status bit to assure that any delayed commands have been completed.
2. CPU loads data to be written to display memory into the interface latch.
3. CPU writes beginning address of memory block into cursor address register and ending address of block into pointer address register.
4. CPU issues 'write from cursor to pointer' command.
5. AVDC generates control signals and outputs block addresses to copy data from the interface latch into the specified block of memory.
6. AVDC sets RDFLG status to indicate that the block write is completed.

Similar sequences can be implemented on an interrupt driven basis using the READY interrupt output to advise the CPU that a previously asserted delayed command has been completed.

Two timing sequences are possible for the 'read/write at cursor/pointer' commands. If the command is given during the active display window (defined as first scan line of the first character row to the last scan line of the last character row), the operation takes place during the next horizontal blanking interval, as illustrated in Figure 3. If the command is given during the vertical blanking interval, or while the display has been commanded blanked, the operation takes place immediately. In the latter case, the execution time for the command is approximately five character clocks (see Figure 4).

# Advanced Video Display Controller (AVDC)

SCN2674

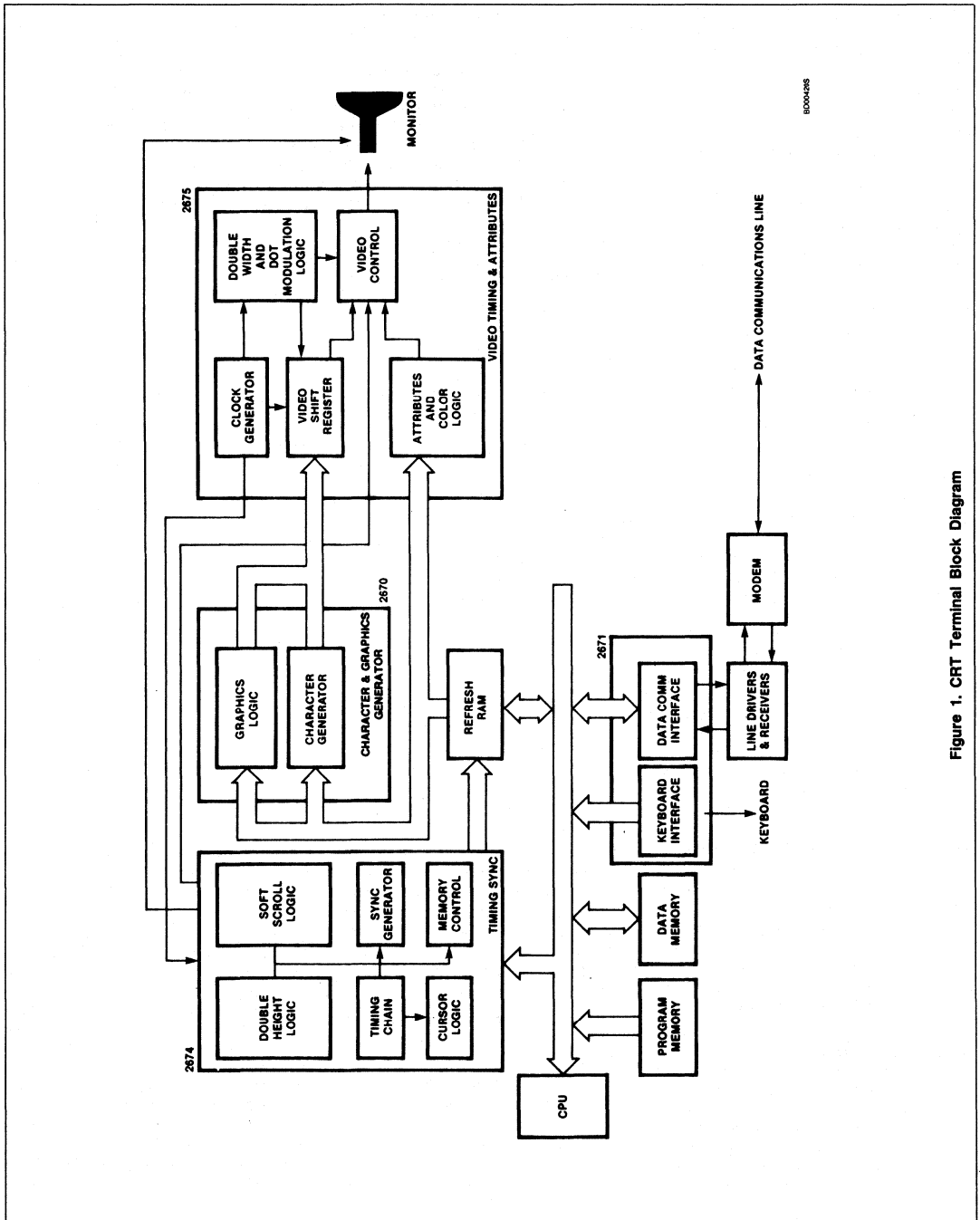

# Advanced Video Display Controller (AVDC)

SCN2674

2

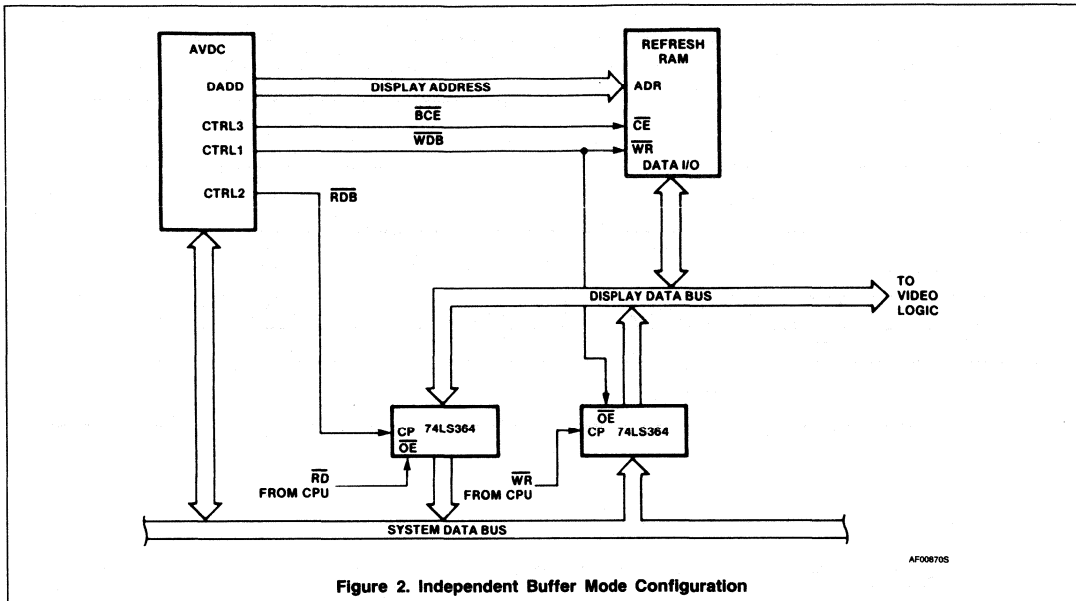
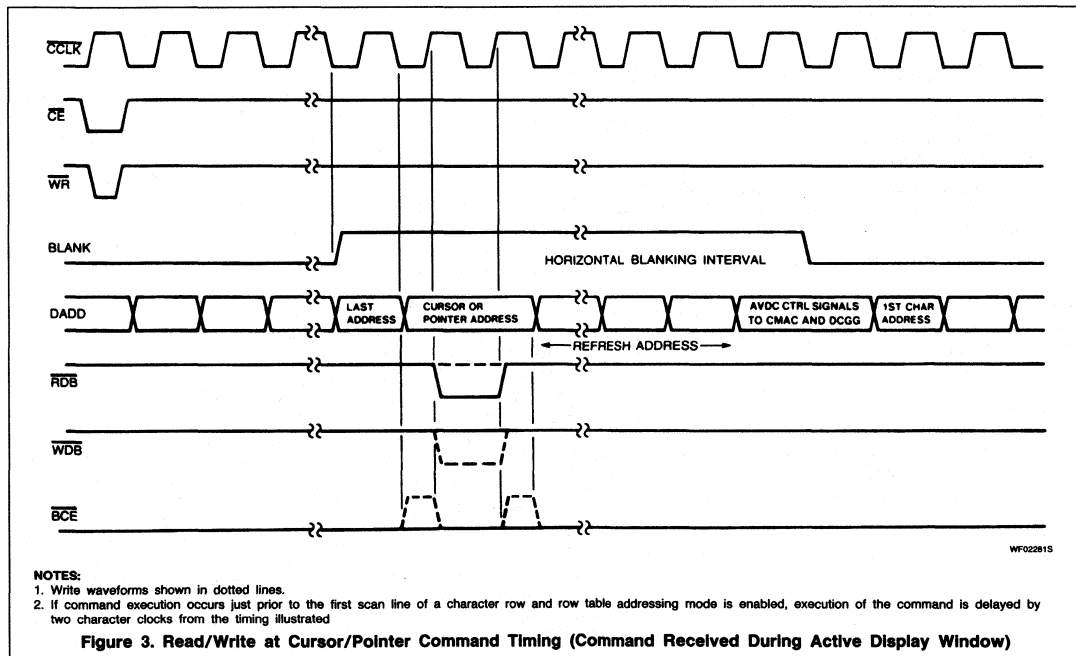

Figure 2. Independent Buffer Mode Configuration



**NOTES:**

1. Write waveforms shown in dotted lines.
2. If command execution occurs just prior to the first scan line of a character row and row table addressing mode is enabled, execution of the command is delayed by two character clocks from the timing illustrated

Figure 3. Read/Write at Cursor/Pointer Command Timing (Command Received During Active Display Window)

## Advanced Video Display Controller (AVDC)

SCN2674

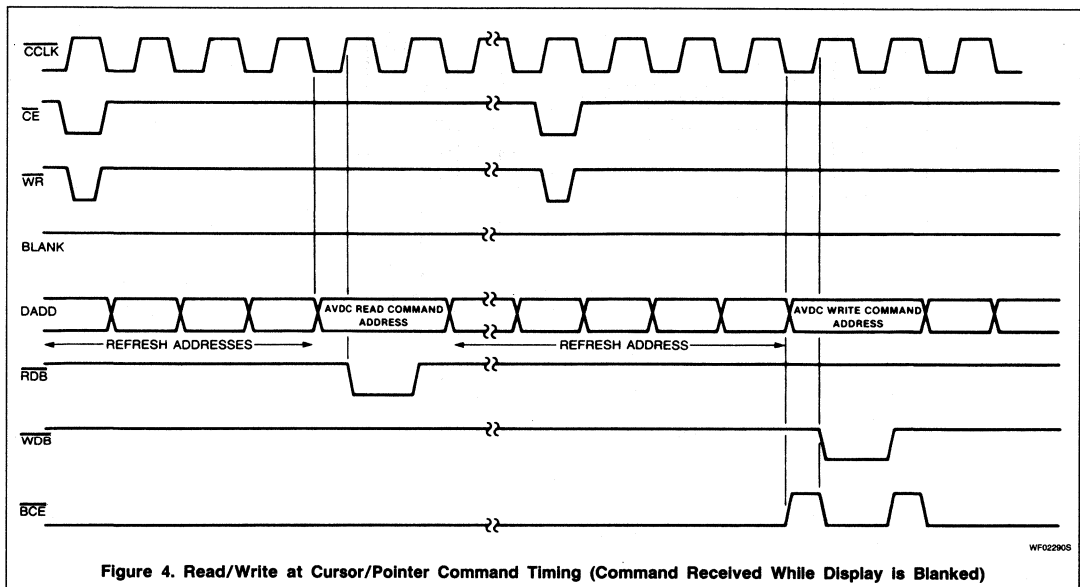

Figure 4. Read/Write at Cursor/Pointer Command Timing (Command Received While Display is Blanked)

Timing for the 'read/write from cursor to pointer' operation is shown in Figure 5. The memory is filled at a rate of one location per two character times. The command will execute only during blanking intervals and may require many horizontal or vertical blanking intervals to complete. Additional delayed commands can be asserted immediately after this command has completed.

Immediate commands can be asserted at any time regardless of the state of the ready status/interrupt.

### Shared and Transparent Buffer Modes

In these modes, the display buffer RAM is a part of the CPU memory domain and is addressed directly by the CPU. Both modes use the same hardware configuration with the CPU accessing the display buffer via 3-State drivers (see Figure 6). The processor bus request (PBREQ) control signal informs the AVDC that the CPU is requesting access to the display buffer. In response to this request, the AVDC raises bus acknowledge (BACK) until its bus external (BEXT) output has freed the display address and data buses for CPU access. BACK, which can be used as a 'hold' input to the CPU, is then lowered to indicate that the CPU can access the buffer.

In transparent mode, the AVDC delays the granting of the buffer to the CPU until a

vertical or horizontal blanking interval, thereby causing minimum disturbance of the display. In shared mode, the AVDC will blank the display and grant immediate access to the CPU. Timing for these modes is illustrated in Figures 7, 8, and 9.

### Row Buffer Mode

Figures 10 and 11 show the timing and a typical hardware implementation for the row buffer mode. During the first scan line (line 0) of each character row, the AVDC halts the CPU and DMAs the next row of character data from the system memory to the row buffer memory. The AVDC then releases the CPU and displays the row buffer data for the programmed number of scan lines. The control signal BREQ informs the CPU that character addresses and the MBC signal will start at the next falling edge of BLANK. The CPU must release the address and data buses before this time to prevent bus contention. After the row of character data is transferred to the row buffer RAM, BREQ returns high to grant memory control back to the CPU.

### Row Table Addressing Mode

In this mode, each character row in the screen image memory has a unique starting address. This provides greater flexibility with respect to screen operations, such as editing, than the sequential addressing mode. The row table, Figure 12, is a list of starting

addresses for each character row and may reside anywhere in the AVDC's addressable memory space. Each entry in the table consists of two bytes: the first byte contains the 8 LSBs of the row starting address and the second byte contains, in its 6 least significant bits, the 6 MSBs of the row starting address. The function of the two MSBs of the second byte is selected by programming IR0[7]. They may be used either as row attribute bits to control double width and double height for that character row, or as an additional two address bits to extend the usable display memory to 64k.

The first address of the row table is designated in screen start register two (SSR2). If row table addressing is enabled via IR2[7], and the display is on, the AVDC fetches the next row's starting address from the table during the blanking interval prior to the first scan line of each character row, while simultaneously incrementing the contents of SSR2 by two so as to point to the next table entry. The fetching of the row starting address from the row table is indicated by the assertion of the CURSOR output during BLANK. The address read from the table by the AVDC is loaded into screen start register 1 (SSR1) for use internally. Since the contents of SSR2 changes as the table entries are fetched, it must be re-initialized to point to the first table entry during each vertical retrace interval.

Advanced Video Display Controller (AVDC)

SCN2674

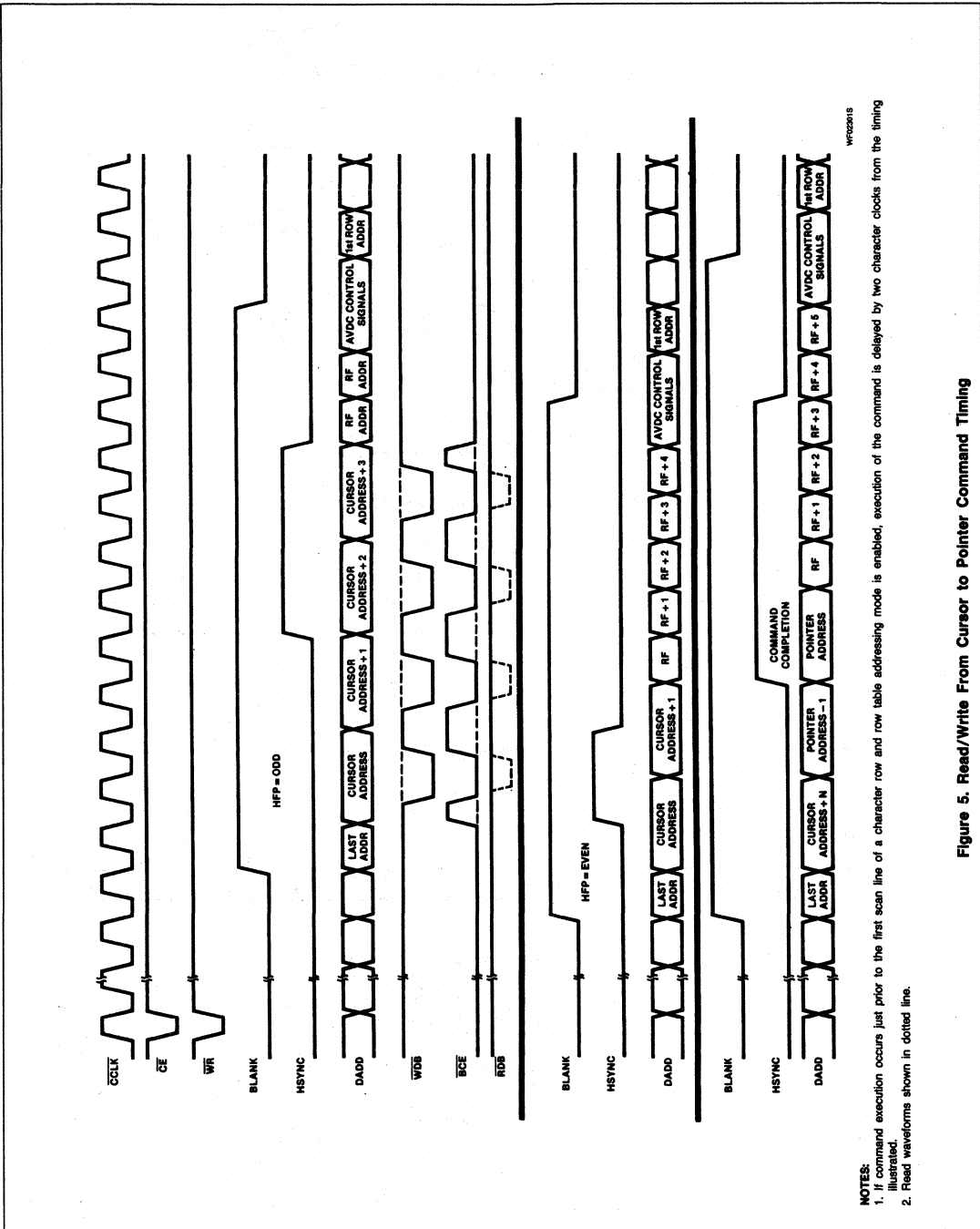

Figure 5. Read/Write From Cursor to Pointer Command Timing

# Advanced Video Display Controller (AVDC)

SCN2674

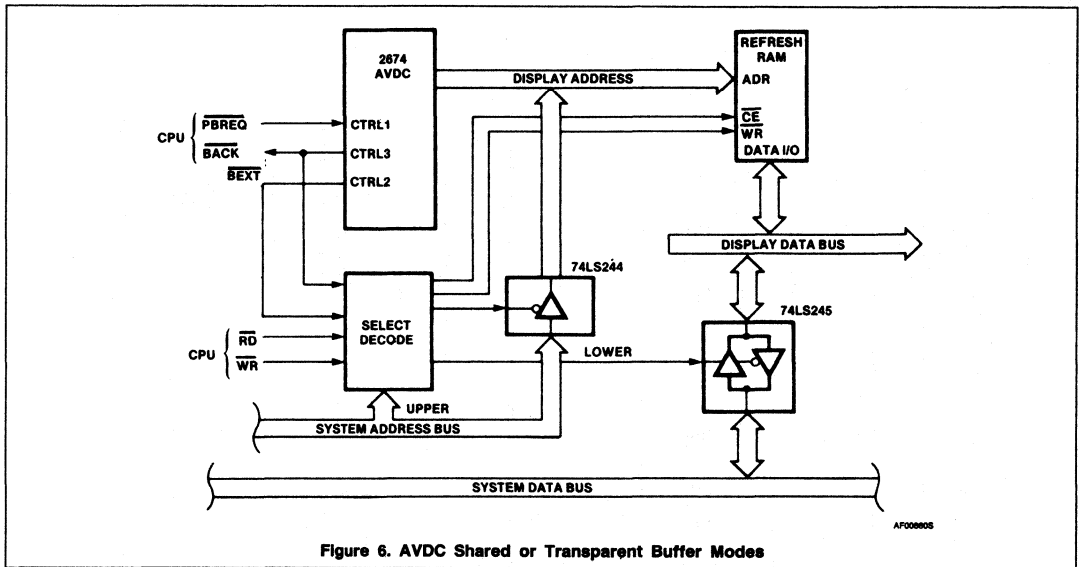
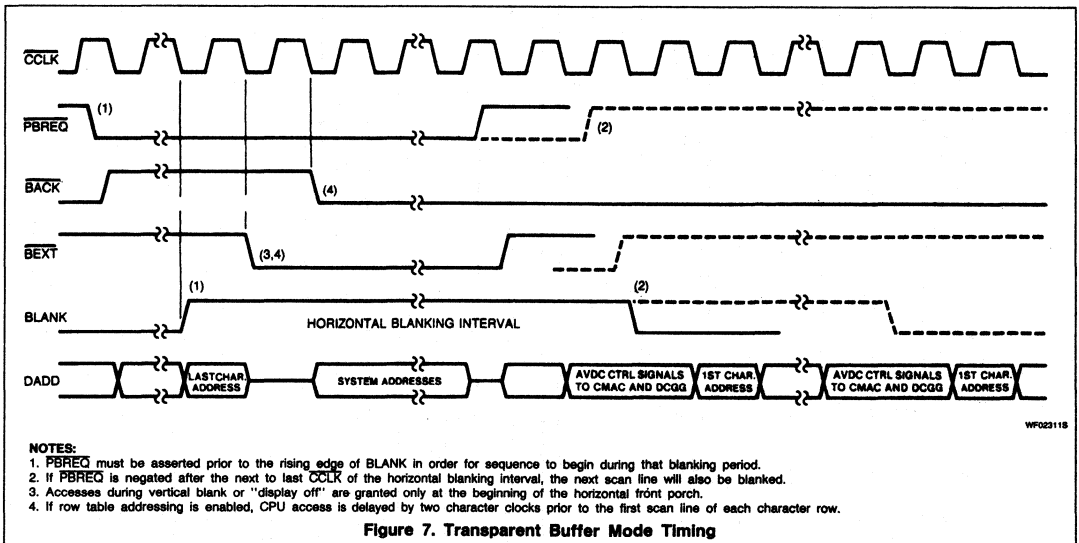

Figure 6. AVDC Shared or Transparent Buffer Modes



**NOTES:**

1. PBREQ must be asserted prior to the rising edge of BLANK in order for sequence to begin during that blanking period.
2. If PBREQ is negated after the next to last CCLK of the horizontal blanking interval, the next scan line will also be blanked.
3. Accesses during vertical blank or "display off" are granted only at the beginning of the horizontal front porch.
4. If row table addressing is enabled, CPU access is delayed by two character clocks prior to the first scan line of each character row.

Figure 7. Transparent Buffer Mode Timing

Advanced Video Display Controller (AVDC)

SCN2674

**2**

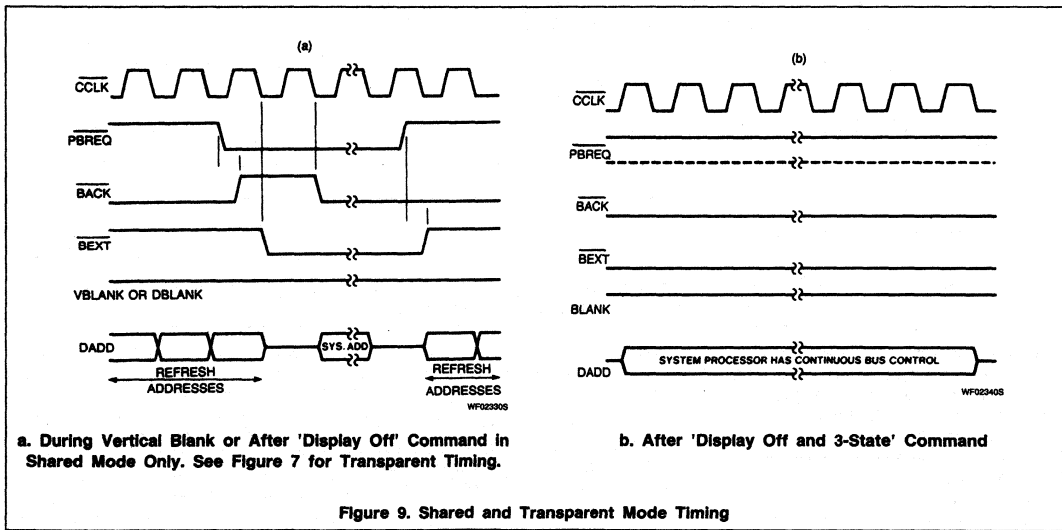
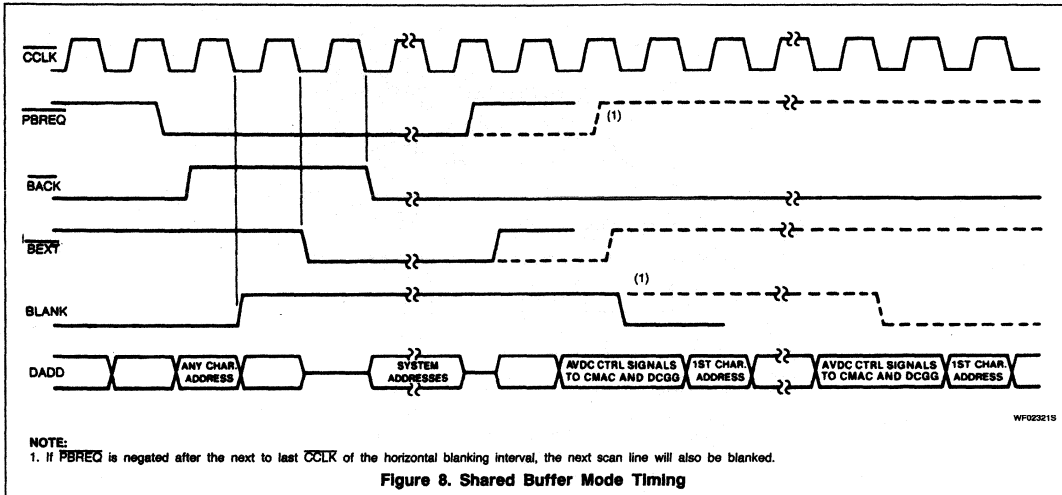

## Advanced Video Display Controller (AVDC)

SCN2674

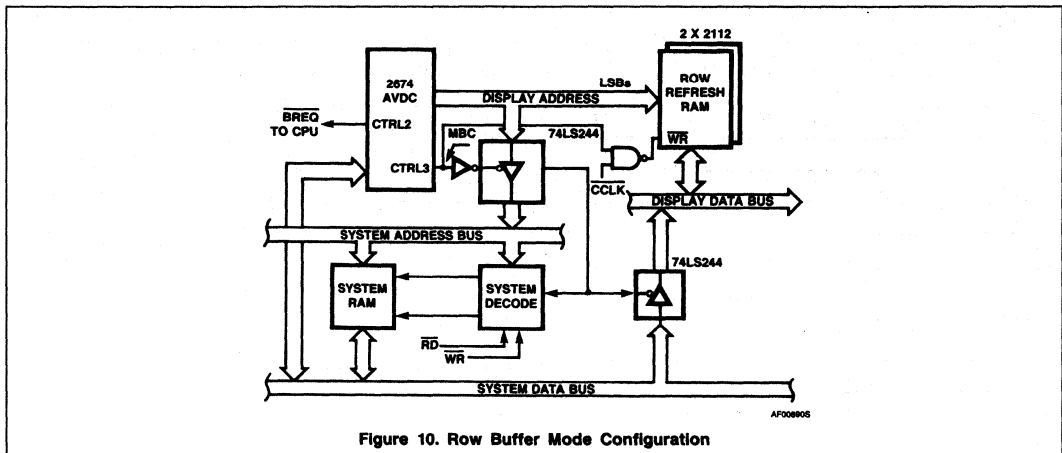
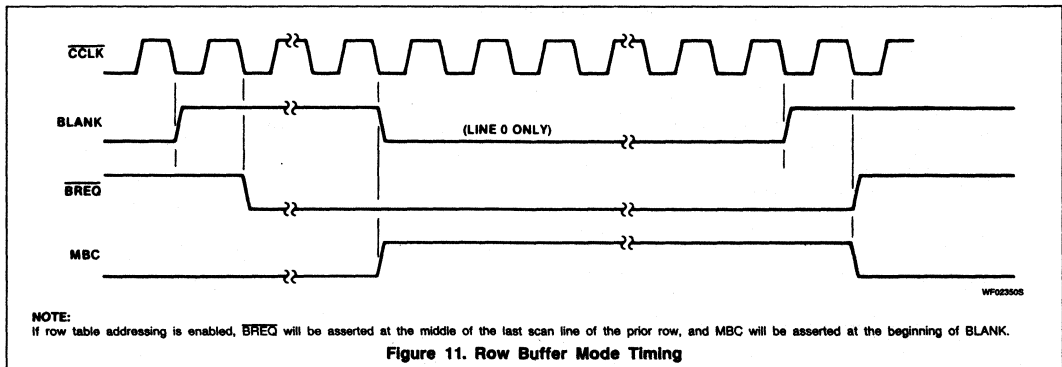

Figure 10. Row Buffer Mode Configuration



NOTE:  
If row table addressing is enabled, BREQ will be asserted at the middle of the last scan line of the prior row, and MBC will be asserted at the beginning of BLANK.

Figure 11. Row Buffer Mode Timing

Row table addressing is intended primarily for use in conjunction with the row buffer mode of operation and requires no additional circuitry in that case. It may also be used with the independent and transparent buffer modes, but circuitry must be added to route the data from the display memory to the data bus inputs of the AVDC. Additionally, when not operating in row buffer mode, care must be taken to assure that the CPU does not attempt to access the AVDC while it is reading the row table. One way of preventing this is to latch the last line output which is multiplexed on DADD13 and to test this latch prior to reading or writing the AVDC. The

AVDC should only be accessed if the latch is low, indicating that the last line of the row is not active.

Figure 13 illustrates a typical hardware implementation for use in conjunction with independent and transparent modes, and Figure 14 shows the timing for row table operation.

#### OPERATION

After power is applied, the AVDC will be in an inactive state. Two consecutive 'master reset' commands are necessary to release this circuitry and ready the AVDC for operation. Two register groups exist within the AVDC:

the initialization registers and the display control registers. The initialization registers select the system configuration, monitor timing, cursor shape, display memory domain, pointer address, scrolling region, double height and width condition, and screen format. These are loaded first and normally require no modification except for certain special visual effects. The display control registers specify the memory address of the base character (upper left corner of screen), the cursor position, and the split screen addresses associated with the scrolling area or an alternate memory. These may require modification during operation.



## Advanced Video Display Controller (AVDC)

SCN2674

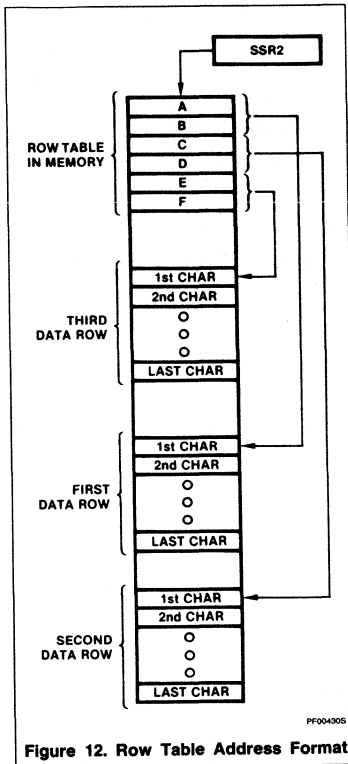

Figure 12. Row Table Address Format

After initial loading of the two register groups, the AVDC is ready to control the monitor screen. Prior to executing the AVDC commands which turn on the display and cursor, the user should load the display memory with the first data to be displayed. During operation, the AVDC will sequentially address the display memory within the limits programmed into its registers. The memory outputs character codes to the system character and graphics generation logic, where they are converted to the serial video stream necessary to display the data on the CRT. The user effects changes to the display by modifying the contents of the display memory, the AVDC display control and command registers, and the initialization registers, if required. Interrupts and status conditions generated by the AVDC supply the 'handshaking' information necessary for the CPU to effect real-time display changes in the proper time frame if required.

### Initialization Registers

There are 15 initialization registers (IR0 - IR14) which are accessed sequentially via a single address. The AVDC maintains an internal pointer to these registers which is incremented after each write at this address until the last register (IR14) is accessed. The pointer then continues to point to IR14 for further accesses. Upon a power-on or a master reset command, the internal pointer is reset to point to the first register (IR0) of the initialization register group. The internal pointer can also be preset to any register of the group via the 'load IR address pointer' command. These registers are write only and are used to specify parameters such as the system configuration, display format, cursor shape, and monitor timing. Register formats are shown in Table 2.

#### IR0[7] - Double Height/Width Enable

When this bit is set, the value in IR14[7:6] is used to control the double height and width conditions of each character row. Assertion of this bit also allows IR14[7:6] to be programmed in two ways:

1. By the CPU writing to IR14 directly.
2. When the contents of screen start register 1 (SSR1) upper are changed, either by the CPU writing to this register or by the automatic loading of SSR1 when operating in row table mode, the two MSBs of SSR1 upper are copied into IR14[7:6]. Thus, the MSBs of each row table entry can be used to control double height and double width attributes on a row by row basis.

IR14[5:4] are not active when this bit is set. When this bit is reset, the double height and width attributes operate as described in IR[14].

#### IR0[8:3] - Scan Lines Per Character Row

Both interlaced and non-interlaced scanning are supported by the AVDC. For interlaced mode, two different formats can be implemented, depending on the interconnection between the AVDC and the character generator (see IR1[7]). This field defines the number of scan lines used to compose a character row for each technique. As scanning occurs, the scan line count is output on the LA0 - LA3 and ODD pins.

#### IR0[2] - VSYNC/CSYNC Enable

This bit selects either vertical sync pulses or composite sync pulses on the VSYNC/CSYNC output (pin 18). The composite sync waveform conforms to EIA RS-170 stan-

dards, with the vertical interval composed of six equalizing pulses, six vertical sync pulses, and six more equalizing pulses.

#### IR0[1:0] - Buffer Mode Select

Four buffer memory modes may be selectively enabled to accommodate the desired system configuration. (See System Configurations).

#### IR1[7] - Interlace Enable

Specifies interlaced or non-interlaced timing operation. Two modes of interlaced operation are available, depending on whether LA0 - LA3 or ODD, LA0 - LA2 are used as the line address for the character generator. The resulting displays are shown in Figure 15.

For 'interlaced sync' operation, the same information is displayed in both odd and even fields, resulting in enhanced readability. The AVDC outputs successive line numbers in ascending order on the LA0 - LA3 lines, one per scan line for each field.

The 'interlaced sync and video' format doubles the character density on the screen. The AVDC outputs successive line numbers in ascending order on the ODD and LA0 - LA2 lines, one per scan line for each field. The number of scan lines per character row is always even. Assume that the first character row is row 0 (even). When scanning through the odd field, the scan line numbers being displayed are odd for both the even and odd character rows. When scanning through the even field, the scan line numbers being displayed are even for both even and odd character rows (see Figure 15).

#### IR1[6:0] - Equalizing Constant

This field indirectly defines the horizontal front porch and is used internally to generate the equalizing pulses for the RS-170 compatible CSYNC. The value for this field is the total number of character clocks (CCLKs) during a horizontal line period divided by two, minus two times the number of character clocks in the horizontal sync pulse:

$$EC = \frac{H_{ACT} + H_{FP} + H_{VSYNC} + H_{BP}}{2} - 2(H_{VSYNC})$$

The definition of the individual parameters is illustrated in Figure 16. The minimum value of  $H_{FP}$  is three character clocks, four CCLKs for row table addressing. Note that when using the 2675 CMAC, it will delay the blank pulse three CCLKs relative to the HSYNC pulse. Because of this delay, the actual HFP and HBP values will be different from the values programmed into the AVDC. The actual HFP will be decreased by 3 character clocks. The actual HBP will be increased by 3 character clocks.

## Advanced Video Display Controller (AVDC)

SCN2674

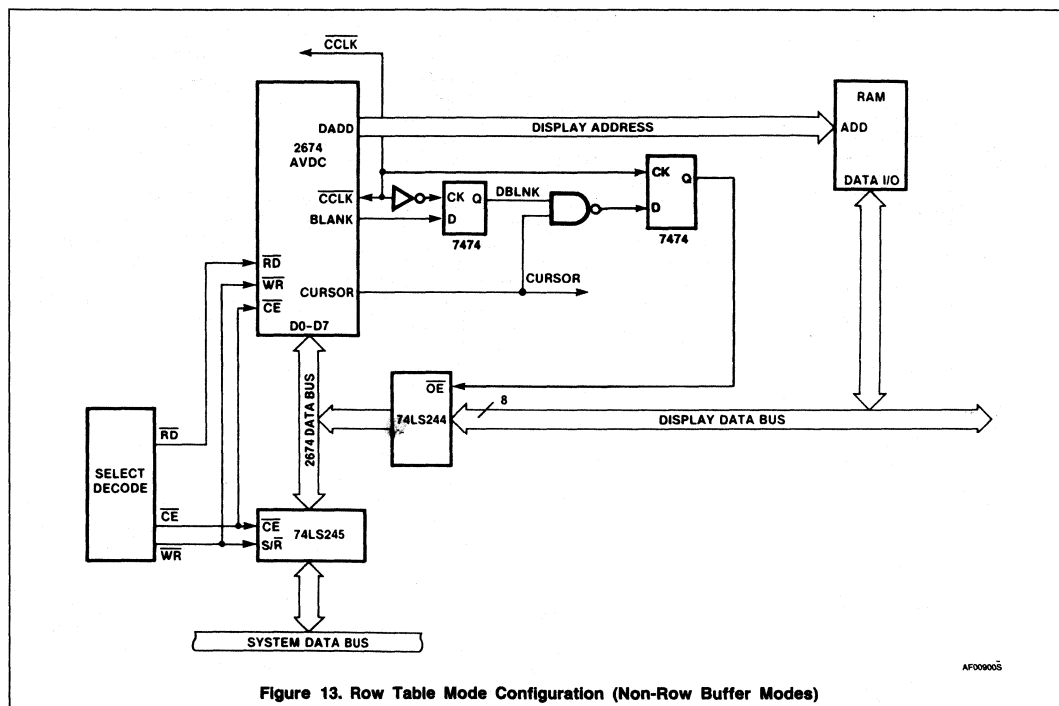

Figure 13. Row Table Mode Configuration (Non-Row Buffer Modes)

AF000005

**IR2[7] — Row Table Mode Enable**

Assertion/negation of this bit causes the AVDC to begin/terminate operating in row table mode starting at the next character row. See Row Table Addressing Mode section. By using the split interrupt capability of the AVDC, this mode can be enabled and disabled on a particular character row. This allows a combination of row table and sequential addressing to be utilized to provide maximum flexibility in generating the display.

**IR2[6:3] — Horizontal Sync Pulse Width**

This field specifies the width of the HSYNC pulse in  $\overline{\text{CCLK}}$  periods.

**IR2[2:0] — Horizontal Back Porch**

This field defines the number of  $\overline{\text{CCLK}}$ s between the trailing edge of HSYNC and the trailing edge of BLANK.

**IR3[7:5] — Vertical Front Porch**

Specifies the number of scan line periods between the rising edges of BLANK and VSYNC during the vertical retrace interval. The vertical front porch will be extended in

increments of scan lines if the ACLL input is low at the end of the programmed value.

**IR3[4:0] — Vertical Back Porch**

This field determines the number of scan line periods between the falling edges of the VSYNC and BLANK outputs.

**IR4[7] — Character Blink Rate**

Specifies the frequency for the character blink attribute timing. The blink rate can be specified as  $1/64$  or  $1/128$  of the vertical field rate. The timing signal has a duty cycle of 50% and is multiplexed onto the DADD11/BLINK output at the falling edge of each BLANK.

**IR4[6:0] — Character Rows Per Screen**

This field defines the number of character rows to be displayed. This value multiplied by the scan lines per character row, plus the vertical front porch, the vertical back porch values, and the vertical sync pulse width is the vertical scan period in scan lines.

**IR5[7:0] — Active Characters Per Row**

This field determines the number of characters to be displayed on each row of the CRT screen. The sum of this value, the horizontal front porch, the horizontal sync width, and the horizontal back porch is the horizontal scan period in  $\overline{\text{CCLK}}$ s.

**IR6[7:4], IR6[3:0] — First and Last Scan Line of Cursor**

These two fields specify the height and position of the cursor on the character block. The 'first' line is the topmost line when scanning from the top to the bottom of the screen. The value of the 'first line of cursor' must be less than the 'last line of cursor' value.

**IR7[7:6] — Vertical Sync Pulse Width**

This field specifies the width of the VSYNC pulse in scan line periods.

**IR7[5] — Cursor Blink Enable**

This bit controls whether or not the cursor output pin will be blinked at the selected rate (IR7[4]). The blink duty cycle for the cursor is 50%.

Advanced Video Display Controller (AVDC)

SCN2674

**2**

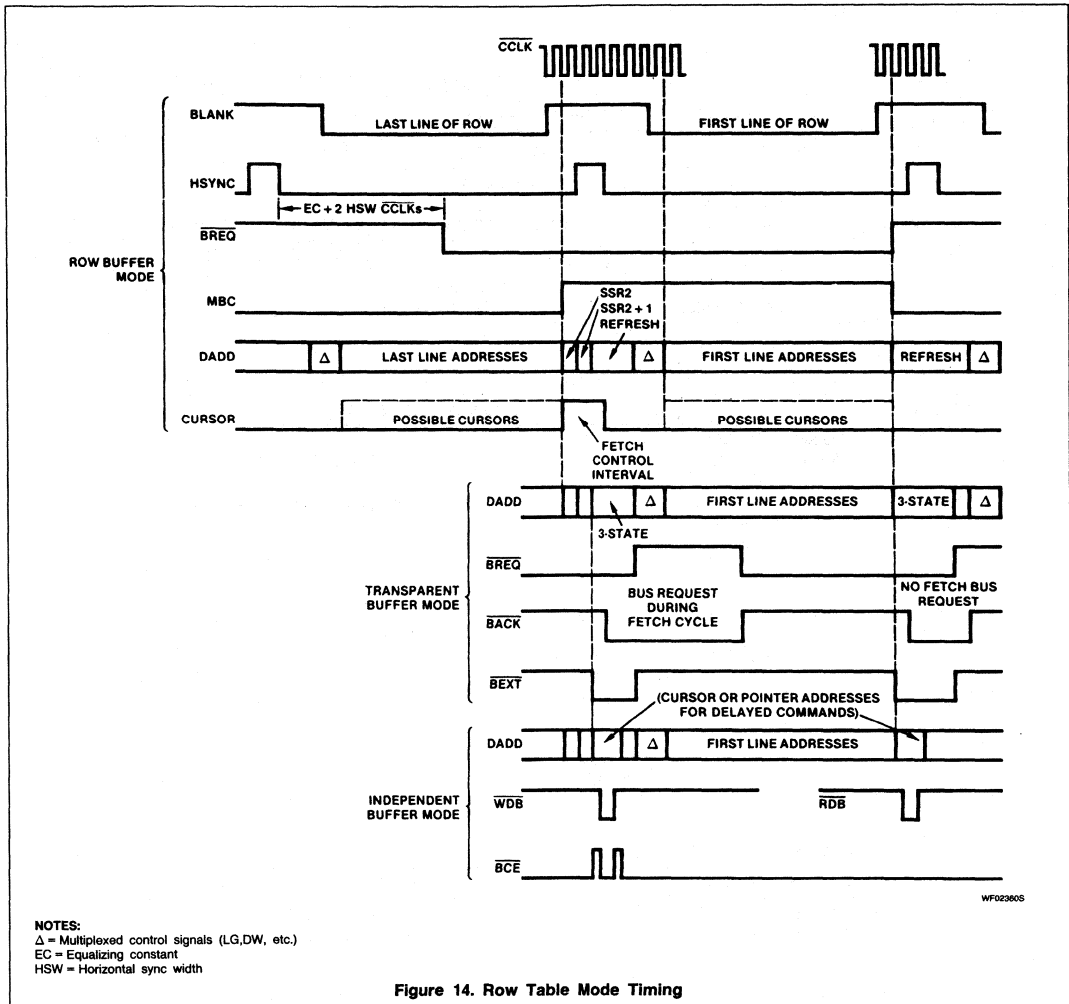

Figure 14. Row Table Mode Timing

## Advanced Video Display Controller (AVDC)

SCN2674

Table 2. Initialization Register Bit Formats

	BIT 7	BIT 6	BIT 5	BIT 4	BIT 3	BIT 2	BIT 1	BIT 0	
IR0	DOUBLE HT/WD  0 = OFF 1 = ON	SCAN LINES PER CHARACTER ROW				SYNC SELECT  0 = VSYNC 1 = CSYNC	BUFFER MODE SELECT  00 = INDEPENDENT 01 = TRANSPARENT 10 = SHARED 11 = ROW		
		NON-INTERLACED		INTERLACED					
		0000 = 1 LINE 0001 = 2 LINES 0010 = 3 LINES .	0000 = 2 LINES 0001 = 4 LINES 0010 = 6 LINES .	0000 = 2 LINES 0001 = 4 LINES 0010 = 6 LINES .	0000 = 2 LINES 0001 = 4 LINES 0010 = 6 LINES .				
		1110 = 15 LINES 1111 = 16 LINES	1110 = 30 LINES 1111 = UNDEFINED	1110 = 30 LINES 1111 = UNDEFINED	1110 = 30 LINES 1111 = UNDEFINED				

	BIT 7	BIT 6	BIT 5	BIT 4	BIT 3	BIT 2	BIT 1	BIT 0
IR1	INTERLACE ENABLE  0 = NON-INT 1 = INTER	EQUALIZING CONSTANT						
		CALCULATED FROM:  $EC = 0.5(H_{ACT} + H_{FP} + H_{SYNC} + H_{BP}) - 2(H_{SYNC})$						
		00000000 = 1 CCLK 00000001 = 2 CCLK .						
		11111110 = 127 CCLK 11111111 = 128 CCLK						

	BIT 7	BIT 6	BIT 5	BIT 4	BIT 3	BIT 2	BIT 1	BIT 0	
IR2	ROW TABLE  0 = OFF 1 = ON	HORIZONTAL SYNC WIDTH				HORIZONTAL BACK PORCH			
		0000 = 2 CCLK 0001 = 4 CCLK .				000 = NOT ALLOWED 001 = 3 CCLK .			
		1110 = 30 CCLK 1111 = 32 CCLK				110 = 23 CCLK 111 = 27 CCLK			

	BIT 7	BIT 6	BIT 5	BIT 4	BIT 3	BIT 2	BIT 1	BIT 0
IR3	VERTICAL FRONT PORCH				VERTICAL BACK PORCH			
	000 = 4 SCAN LINES 001 = 8 SCAN LINES .				00000 = 4 SCAN LINES 00001 = 6 SCAN LINES .			
	110 = 28 SCAN LINES 111 = 32 SCAN LINES				11110 = 64 SCAN LINES 11111 = 66 SCAN LINES			

	BIT 7	BIT 6	BIT 5	BIT 4	BIT 3	BIT 2	BIT 1	BIT 0
IR4	CHARACTER BLINK RATE  0 = 1/64 VSYNC 1 = 1/128 VSYNC	ACTIVE CHARACTER ROWS PER SCREEN						
		00000000 = 1 ROW 00000001 = 2 ROWS .						
		11111110 = 127 ROWS 11111111 = 128 ROWS						

## Advanced Video Display Controller (AVDC)

SCN2674

Table 2. Initialization Register Bit Formats (Continued)

	BIT 7	BIT 6	BIT 5	BIT 4	BIT 3	BIT 2	BIT 1	BIT 0
	<b>ACTIVE CHARACTERS PER ROW</b>							
IR5	0000010 = 3 CHARACTERS							
	0000011 = 4 CHARACTERS							
	.							
	1111110 = 255 CHARACTERS							
	1111111 = 256 CHARACTERS							

	BIT 7	BIT 6	BIT 5	BIT 4	BIT 3	BIT 2	BIT 1	BIT 0
	<b>FIRST LINE OF CURSOR</b>				<b>LAST LINE OF CURSOR</b>			
IR6	0000 = SCAN LINE 0				0000 = SCAN LINE 0			
	0001 = SCAN LINE 1				0001 = SCAN LINE 1			
	.				.			
	1110 = SCAN LINE 14				1110 = SCAN LINE 14			
	1111 = SCAN LINE 15				1111 = SCAN LINE 15			

	BIT 7	BIT 6	BIT 5	BIT 4	BIT 3	BIT 2	BIT 1	BIT 0
	<b>VSYNC WIDTH</b>		<b>CURSOR BLINK</b>	<b>CURSOR RATE</b>	<b>UNDERLINE POSITION</b>			
IR7	00 = 3 SCAN LN		0 = OFF 1 = ON	0 = $\frac{1}{32}$ 1 = $\frac{1}{64}$	0000 = SCAN LINE 0			
	01 = 1 SCAN LN				0001 = SCAN LINE 1			
	10 = 5 SCAN LN				.			
	11 = 7 SCAN LN				1110 = SCAN LINE 14			
					1111 = SCAN LINE 15			

	BIT 7	BIT 6	BIT 5	BIT 4	BIT 3	BIT 2	BIT 1	BIT 0
	<b>DISPLAY BUFFER FIRST ADDRESS LSB'S</b>							
IR8	H'000 = 0							
	H'001 = 1							
	.							
	H'FFE = 4,094							
	H'FFF = 4,095							
	<b>NOTE: MSB'S ARE IN IR9[3:0]</b>							

	BIT 7	BIT 6	BIT 5	BIT 4	BIT 3	BIT 2	BIT 1	BIT 0
	<b>DISPLAY BUFFER LAST ADDRESS</b>				<b>DISPLAY BUFFER FIRST ADDRESS MSB'S</b>			
IR9	0000 = 1,023				SEE IR8			
	0001 = 2,047							
	.							
	1110 = 15,359							
	1111 = 16,383							

2

# Advanced Video Display Controller (AVDC)

SCN2674

Table 2. Initialization Register Bit Formats (Continued)

	BIT 7	BIT 6	BIT 5	BIT 4	BIT 3	BIT 2	BIT 1	BIT 0
IR10	DISPLAY POINTER ADDRESS LOWER							
	SEE IR11							

	BIT 7	BIT 6	BIT 5	BIT 4	BIT 3	BIT 2	BIT 1	BIT 0
IR11	LZ DOWN	LZ UP	DISPLAY POINTER ADDRESS UPPER					
	0 = OFF 1 = ON	0 = OFF 1 = ON	H'0000' = 0 H'0001' = 1 . . H'3FFF' = 16,383					

	BIT 7	BIT 6	BIT 5	BIT 4	BIT 3	BIT 2	BIT 1	BIT 0
IR12	SCROLL START	SPLIT REGISTER 1						
	0 = OFF 1 = ON	00000000 = ROW 1 00000001 = ROW 2 . . 11111111 = ROW 128						

	BIT 7	BIT 6	BIT 5	BIT 4	BIT 3	BIT 2	BIT 1	BIT 0
IR13	SCROLL END	SPLIT REGISTER 2						
	0 = OFF 1 = ON	00000000 = ROW 1 00000001 = ROW 2 . . 11111111 = ROW 128						

	BIT 7	BIT 6	BIT 5	BIT 4	BIT 3	BIT 2	BIT 1	BIT 0
IR14	DOUBLE 1		DOUBLE 2		LINES TO SCROLL			
	00 = NORMAL 01 = DOUBLE WIDTH 10 = DB WD & TOPS 11 = DB WD & BOTS	00 = NORMAL 01 = DOUBLE WIDTH 10 = DB WD & TOPS 11 = DB WD & BOTS	0000 = 1 0001 = 2 . . 1110 = 15 1111 = 16	SCAN LINE 0 SCAN LINE 1 . . SCAN LINE 14 SCAN LINE 15				

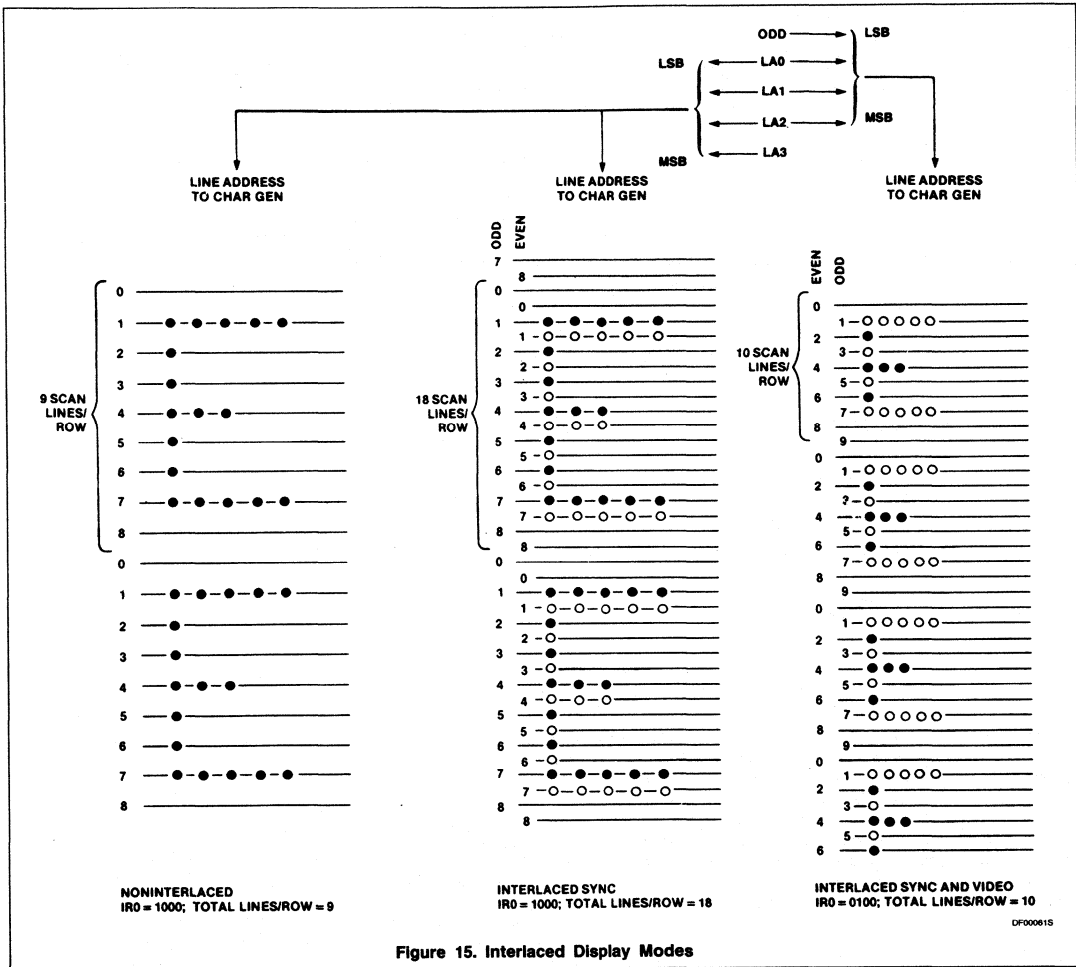

**IR7[4] — Cursor Blink Rate**

The cursor blink rate can be specified at 1/32 or 1/64 of the vertical scan frequency. Blink is effective only if blink is enabled by IR7[5].

**IR7[3:0] — Underline Position**

This field defines which scan line of the character row will be used for the underline attribute by the 2675 CMAC. The timing signal

is multiplexed onto the DADD10/UL output during the falling edge of BLANK.

**IR9[3:0], IR8[7:0] — Display Buffer First Address**

**IR9[7:4] — Display Buffer Last Address**  
 These two fields define the area within the buffer memory where the display data will reside. When the data at the 'display buffer last address' is displayed, the AVDC will

wraparound and obtain the data to be displayed at the next screen position from the 'display buffer first address'. If 'last address' is the end of a character row and a new screen start address has been loaded into the screen start register, or if 'last address' is the last character position of the screen, the next data is obtained from the address contained in the screen start register.

## Advanced Video Display Controller (AVDC)

SCN2674

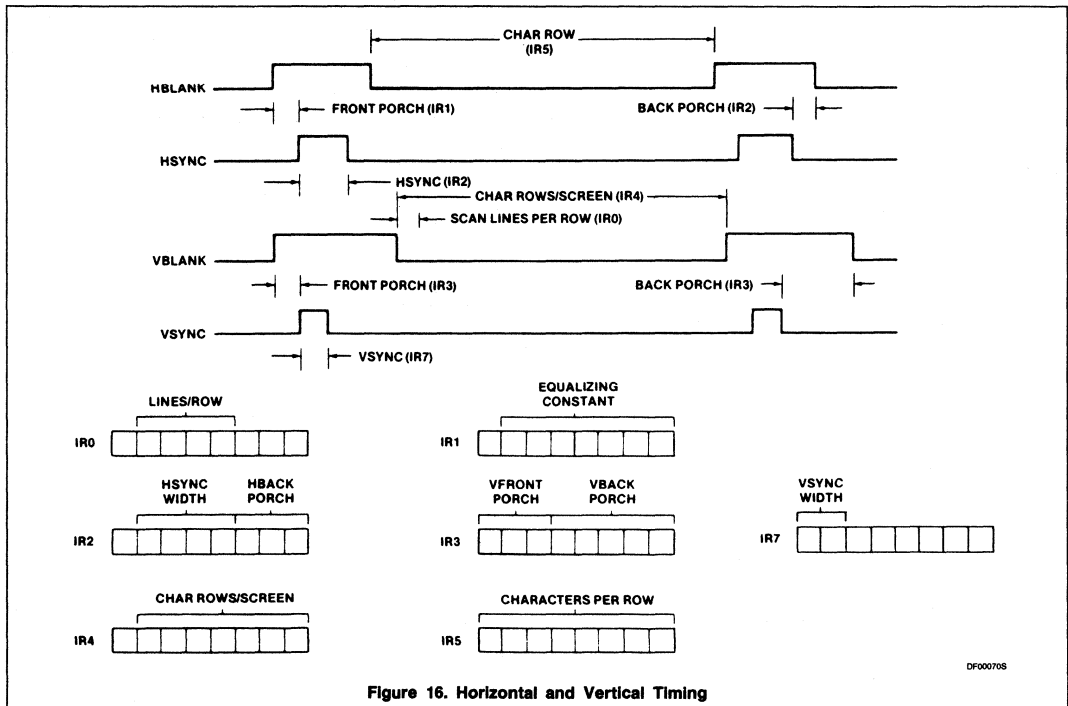

Figure 16. Horizontal and Vertical Timing

Note that there is no restriction in displaying data from other areas of the addressable memory. Normally, the area between these two bounds is used for data which can be overwritten (e.g., as a result of scrolling), while data that is not to be overwritten would be contained outside these bounds and accessed by means of the automatic split screen or split screen interrupt feature of the AVDC.

**IR10[7:0] — Display Pointer Address, Lower****IR11[5:0] — Display Pointer Address, Upper**

These two fields define a buffer memory address for AVDC controlled accesses in response to 'read/write at pointer' commands. They also define the last buffer memory address to be written for the 'write from cursor to pointer' command.

In the independent mode, the RDFLG bit of the status register should be checked for the ready state (bit 5 equal to a logic one) before writing to the display pointer address registers. Checking the status register will prevent the pointer address from being changed while a delayed command (e.g. write from cursor to pointer) is still being executed.

**IR11[7] — Scan Line Zero During Scroll Down**

During a scroll down operation, the new character row will appear at the top of the scrolling region. If this bit is set (logic one), the scan line count pins (LA0 through LA3) will be forced to zero for every scan line of the partial row. If the character generator provides blanks for scan line zero, the new row being scrolled into the screen will be blanked. This feature can be used to blank the new row to give the CPU time to load the new data in the display buffer. When this bit is set to a logic zero, the new data will be displayed.

**IR11[6] — Scan Line Zero During Scroll Up**

During a scroll up operation, the new character row will appear at the bottom of the scrolling region. If this bit is set (logic one), the scan line count pins (LA0 through LA3) will be forced to zero for every scan line of the partial row. If the character generator provides blanks for scan line zero, the new row being scrolled into the screen will be blanked. This feature can be used to blank the new row to give the CPU time to load the new data in the display buffer. When this bit is

set to a logic zero, the new data will be displayed.

**IR12[7] — Scroll Start**

This bit is asserted when soft scroll is to take place. The scrolling area begins at the row specified in split register 1 (IR12[6:0]). If set, the first row to scroll scan line count will be reduced by the value in the lines to scroll register (IR14[3:0]). The scan line count of this row will start at the programmed offset value. When this bit is asserted, scroll end IR13[7] must be set before split 2.

**IR12[6:0] — Split Register 1**

Split register 1 can be used to provide special screen effects such as soft (scan line by scan line) scrolling, double height/width rows, or to change the normal addressing sequence of the display memory. The contents of this field are compared, in real time, to the current row number. Upon a match, the AVDC sets the split screen 1 status bit, and issues an interrupt request if so programmed. The status change/interrupt request is made at the beginning of scan line zero of the split screen character row. If enabled by the SPL1 bit of screen start register 2, an automatic split screen to the address specified in screen start register 2 will be made for the designated character row. During a scroll operation,



## Advanced Video Display Controller (AVDC)

SCN2674

this field defines the first character row of the scrolling area.

**IR13[7] — Scroll End**

This field specifies that the row programmed in split register 2 (IR13[6:0]) is to be the last scrolling row of the scrolling area. Note that this bit must be asserted for a valid row only when the scroll start bit IR12[7] is also asserted.

**IR13[6:0] — Split Register 2**

This field is similar to the split register 1 field except for the following:

1. Split screen 2 status bit is set.
2. During a scroll operation, this field defines the last character row of the scrolling area. This row will be followed by a partial row. The LTSR (IR14) value replaces the normal scan lines/row value for the partial row, thus keeping the total scan lines/screen the same.
3. If enabled by the SPL2 bit of screen start register 2, an automatic split to the address contained in screen start register 2 will occur in one of two ways: a) If not scrolling an automatic split will occur for the next character row. b) If scrolling, the automatic split will occur after the partial row being scrolled onto or off the screen.
4. The specified double width and height conditions (IR14) are also asserted in two possible ways: a) Automatic split will assert the programmed condition for the current row. b) During soft scroll operation the programmed conditions are asserted for the partial row scrolling onto or off the screen.

**IR14[7:6] — Double 1**

This field specifies the conditions (double width/height or normal) of the row designated in split register 1 (IR12[6:0]). When double height tops or bottoms have been specified, the AVDC will automatically toggle between tops and bottoms until another split 1 or 2 occurs which changes the double height/width condition. If a double height top row is specified, the scan line count will start at zero and increment the scan line count every other scan line. If a double height bottom row is specified, the AVDC will start at one-half the normal scan line total. If double width is specified, the AVDC will assert the DADD9/DW output at the falling edge of blank. This condition will also remain active until the next split 1 or 2. When IR0[7] = 1, the values written into bits 7 and 6 of screen start 1 upper will also be written into IR14[7:6] and the automatic toggling between tops and bottoms is disabled.

The AVDC still addresses the RAMs on a single width character basis. The clock rate of the AVDC does not change. The display RAMs must have data as if two single-wide

characters are to be displayed. The first data bits addressed by the AVDC will specify the double wide character. The next data bits addressed are not displayed. The 2675 CMAC will ignore the second clock cycle data when the ADOUBLE pin is high.

**IR14[5:4] — Double 2**

This field specifies the conditions (double width/height or normal) of the row designated in split register 2 (IR13[6:0]). Not used when IR0[7] = 1.

**IR14[3:0] — Lines To Scroll**

This field defines the scan line increment to be used during a soft scroll operation. These 4 bits control the scroll rate. When smooth scrolling up by scan line increments of one, the initial value is 0000 (scan line 0) and is increased every vertical frame according to the number of lines per character row. When smooth scrolling down by scan line increments of one, the initial value is 1110 hex (scan line 14, assuming 15 scan lines per character row) and is decreased by one every vertical frame. This value will only be used when scroll start (IR12[7]) and scroll end (IR13[7]) are enabled.

**Timing Considerations**

Normally, the contents of the initialization registers are not changed during normal operation. However, this may be necessary to implement special display features such as multiple cursors and horizontal scrolling. Table 3 describes timing details for these registers which should be considered when implementing these features.

**Display Control Registers**

There are seven registers in this group, each with an individual address. Their formats are illustrated in Table 4. The command register is used to invoke one of 19 possible AVDC commands as described in the COMMANDS section of this data sheet. The remaining registers in the group store address values which specify the cursor location, the location of the first character to be displayed on the screen, and any split screen address locations. The user initializes these registers after powering on the system and changes their values to control the data which is displayed.

**Screen Start Registers 1 and 2**

The screen start 1 registers contain the address of the first character of the first row (upper left corner of the active display). At the beginning of the first scan line of the first row, this address is transferred to the row start register (RSR) and into the memory address counter (MAC). The counter is then advanced sequentially at the character clock rate for the number of times programmed into the active characters per row register (IR5), thus reaching the address of the last character of the row plus one. At the beginning of each subsequent scan line of the first row, the

MAC is reloaded from the RSR and the above sequence is repeated. At the end of the last scan line of the first row, the contents of the MAC are loaded into the RSR to serve as the starting memory address for the second character row. This process is repeated for the programmed number of rows per screen. Thus, the data in the display memory is displayed sequentially starting from the address contained in the screen start register. After the ensuing vertical retrace interval, the contents of the screen start registers are reloaded into the RSR and MAC, and the process is repeated.

During vertical blanking, the address counter operation is modified by stopping the automatic load of the contents of the RSR into the counter, thereby allowing the address outputs to free-run. This allows dynamic memory refresh to occur during the vertical retrace interval. The refresh addressing starts at the last address displayed on the screen and increments by one for each character clock during the retrace interval. If the display buffer last address is encountered, wraparound will occur. Refreshing will continue from the display buffer first address. In the independent mode, the refresh addressing will occur if no delayed commands are being executed. In the transparent and shared modes, refresh will occur during the blanking interval unless the CPU has control of the display address bus. In the row buffer mode, refresh will occur during all blanking intervals except for the first character clock time in the BLANK after the first scan line (scan line 0) of a character row.

The sequential addressing operation described above will be modified upon the occurrence of the following:

1. After reaching the 'display buffer last address.'
2. Rewriting the contents of the screen start 1 registers.
3. Setting the split register 1 or split register 2 bits of screen start register 2 upper.
4. Enabling the row table addressing mode.

First, if during the incrementing of the memory address counter the 'display buffer last address' (IR9[7:4]) is reached, the MAC will be loaded from the 'display buffer first address' register (IR9[3:0] and IR8[7:0]) at the next character clock. Sequential operation will then resume starting from this address. This wraparound operation allows portions of the display buffer to be used for purposes other than storage of displayable data and is completely automatic without any CPU intervention (see Figure 17a).

Second, if the contents of screen start register 1 (upper, lower, or both) are changed during any character row (e.g., row 'n'), the starting address of the next character row

## Advanced Video Display Controller (AVDC)

SCN2674

(row 'n + 1') will be the new value of the screen start register and addressing will continue sequentially from there. This allows features such as split screen operation, partial scroll, or status line display to be implemented. The split screen interrupt feature of the AVDC is useful in controlling the CPU initiated operations. Note that in order to obtain the correct screen display, screen start register 1 must be reloaded with the original (origin of display) value prior to the end of the vertical retrace. See Figure 17b.

The screen start two registers contain a 14-bit display address. The SSR2 address is implemented on the occurrence of item 3 above. If bit 6 of SSR2 upper is set, the SSR2 contents will be automatically loaded into the RSR at the beginning of the first scan line of the row designated by split register 1 (IR12[6:0]). If bit 7 of SSR2 upper is set, the SSR2 contents will be automatically loaded into the RSR at the beginning of the first scan line of the row specified by split register 2 (IR13[6:0]). SPL1 and SPL2 are write only bits and will read as zero when reading screen start register 2. If these bits are not used, they should be set to zeros after power-up.

In order to avoid screen start register 1 and 2 (SSR1, SSR2) writing sequence conflict, after SSR1 and/or SSR2 are loaded with new values, SSR2 Value needs to be checked. If SSR2 value is incorrect, multiple SSR2 re-writes may be necessary.

Lastly, when row table addressing mode is enabled, the first address of the row table is designated in SSR2. The AVDC fetches the next row's starting address from the table during the blanking interval prior to the first scan line of each character row and loads it into SSR1 for use as the starting address of the next row. Since the contents of SSR2 change as the table entries are fetched, it must be re-initialized to point to the first table entry during each vertical retrace interval.

The values in the two MSBs of SSR1 upper are multiplexed onto the DADD1/DADD14 and DADD2/DADD15 outputs during the falling edge of BLANK. If IR0[7] = 0, these two bits act as memory page select bits which may be used to extend the display memory addressing range of the AVDC up to 64k. In that case, these two bits act as a two-bit counter which is incremented each time that

Table 3. Timing Considerations

PARAMETER	TIMING CONSIDERATIONS
First line of cursor Last line of cursor Underline line	These parameters must be established at a minimum of two character times prior to their occurrence
Double height character rows Double width character rows Rows to scroll	Set/reset prior to the row specified in split 1 or 2 registers
Cursor blink Cursor blink rate Character blink rate	New values become effective within one field after values are changed
Split register 1 Split register 2	Change anytime prior to line zero of desired row
Character rows per screen	Change only during vertical blanking period
Vertical front porch	Change prior to first line of VFP
Vertical back porch	Change prior to fourth line after VSYNC
Screen start register 1 Row table mode enable	Change prior to the horizontal blanking interval of the last line of character row before row where new value is to be used

'wraparound' occurs (see above). Note that the counter is incremented at the falling edge of BLANK and that for proper display operation the wraparound address should be programmed to occur at the last character position of a row. Also, the first address accessed in the new page will be the address contained in the display buffer first address register (IR9[3:0] and IR8[7:0]). DADD14 and DADD15 should only be used in the bit-mapped graphics mode.

#### Cursor Address Registers

The contents of these registers define the buffer memory address of the cursor. The cursor output will be asserted when the memory address counter matches the value of the cursor address registers for the scan lines specified in IR6. The cursor address registers can be read or written by the CPU or incremented via the 'increment cursor address' command. In independent buffer mode, these registers define a buffer memory address for AVDC controlled access in response to 'read/write at cursor with/without increment' commands, or the first address to be used in executing the 'write from cursor to pointer' command.

In the independent mode, the RDFLG bit of the status register should be checked for the

ready state (bit 5 equal to a logic one) before writing to the cursor address registers. Checking the status register will prevent the cursor address from being changed while a cursor delayed command (e.g., write from cursor to pointer) is still being executed.

#### Interrupt/Status Registers

The interrupt and status registers provide information to the CPU to allow it to interact with the AVDC to effect desired changes that implement various display operations. The interrupt register provides information on five possible interrupting conditions, as shown in Table 5. These conditions can be selectively enabled or disabled (masked) from causing interrupts by certain AVDC commands. An interrupt condition which is enabled (mask bit equal to one) will cause the INTR output to be asserted and will cause the corresponding bit in the interrupt register to be set-upon the occurrence of the interrupting condition. An interrupt condition which is disabled (mask bit equal to zero) has no effect on either the INTR output or the interrupt register.

The status register provides six bits of status information: the five possible interrupting conditions plus the RDFLG bit. For this register, however, the contents are not affected by the state of the mask bits.

# Advanced Video Display Controller (AVDC)

SCN2674

**Table 4. Display Control Register Bit Formats**

BIT 7	BIT 6	BIT 5	BIT 4	BIT 3	BIT 2	BIT 1	BIT 0
<b>COMMAND CODE</b>							
SEE COMMANDS SECTION FOR COMMAND CODES							
<b>COMMAND REGISTERS (WRITE ONLY)</b>							

BIT 7	BIT 6	BIT 5	BIT 4	BIT 3	BIT 2	BIT 1	BIT 0
<b>UPPER REGISTER</b>							
Not used		MSBs					

BIT 7	BIT 6	BIT 5	BIT 4	BIT 3	BIT 2	BIT 1	BIT 0
<b>LOWER REGISTER (LSB)</b>							
H'0000' = 0		Note: MSBs are in Upper Register [5:0]					
H'0001' = 1							
THRU							
H'3FFE' = 16,382							
H'3FFF' = 16,383							

**NOTE:**  
Bits 7 and 6 of upper register are not used in the cursor address register.

**CURSOR ADDRESS REGISTERS (READ AND WRITE)**

BIT 7	BIT 6	BIT 5	BIT 4	BIT 3	BIT 2	BIT 1	BIT 0
<b>UPPER REGISTER</b>							
DADD15	DADD14	MSBs					

BIT 7	BIT 6	BIT 5	BIT 4	BIT 3	BIT 2	BIT 1	BIT 0
<b>LOWER REGISTER (LSB)</b>							
H'0000' = 0		NOTE: MSBs ARE IN UPPER REGISTER [5:0]					
H'0001' = 1							
THRU							
H'3FFE' = 16,382							
H'3FFF' = 16,383							

**SCREEN START 1 REGISTERS (READ AND WRITE)**

- NOTES:**
- Bits 7 and 6 of upper register are always zero when read by the CPU.
  - When IR0(7) = 1, the values written into bits 7 and 6 of screen start 1 upper will also be written into IR14(7:6) to control the double width and double height attributes of the display as follows:

Z	6	Attribute
0	0	None
0	1	Double width only
1	0	Double width and double
1	1	Double width and double

BIT 7	BIT 6	BIT 5	BIT 4	BIT 3	BIT 2	BIT 1	BIT 0
<b>UPPER REGISTER</b>							
SPL2 0 = OFF 1 = ON	SPL1 0 = OFF 1 = ON	MSBs					

BIT 7	BIT 6	BIT 5	BIT 4	BIT 3	BIT 2	BIT 1	BIT 0
<b>LOWER REGISTER</b>							
H'0000' = 0		NOTE: MSBs ARE IN UPPER REGISTER [5:0]					
H'0001' = 1							
THRU							
H'3FFE' = 16,382							
H'3FFF' = 16,383							

**SCREEN START 2 REGISTERS (READ AND WRITE)**

- NOTES:**
- Bit 7 and bit 6 are always zero when read by the CPU.
  - These bits should be set to zero after power-up by the user, even if SSR2 is not used.

2

# Advanced Video Display Controller (AVDC)

SCN2674

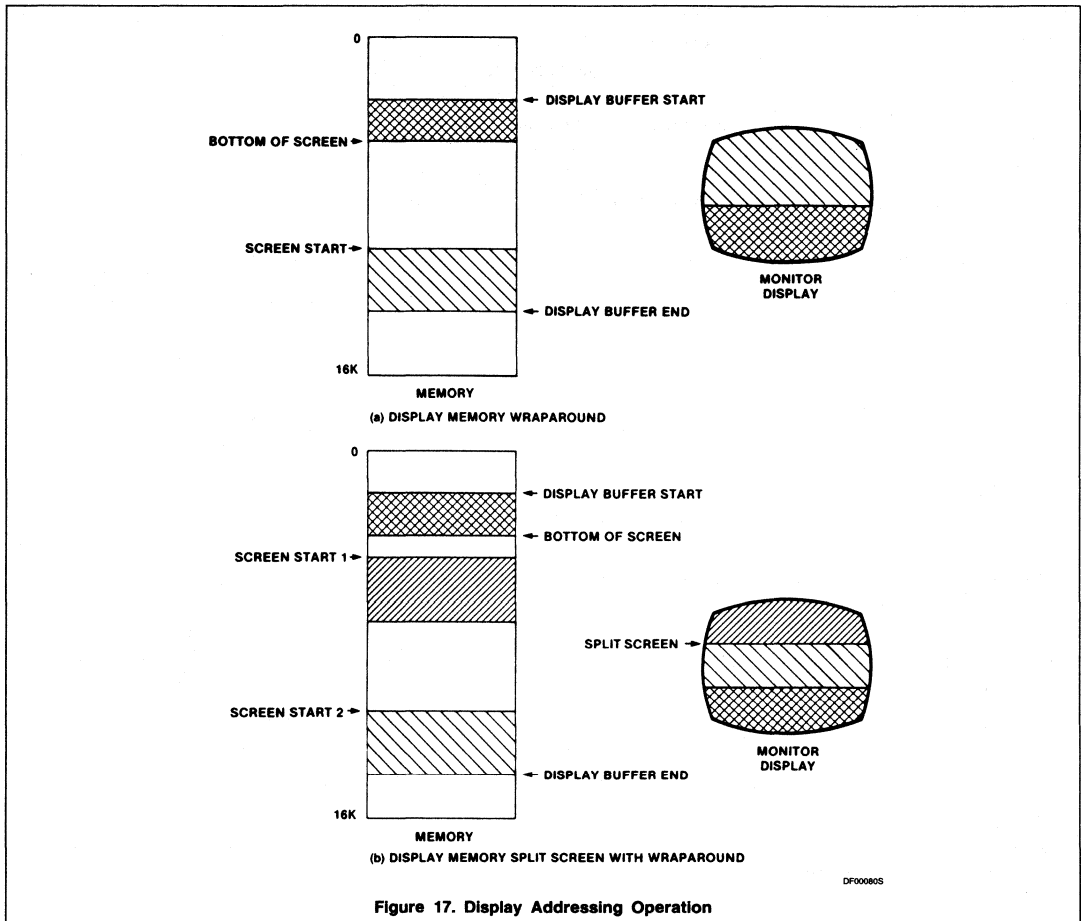

**Table 5. Interrupt and Status Register Bit Formats**

BIT 7	BIT 6	BIT 5	BIT 4	BIT 3	BIT 2	BIT 1	BIT 0
<b>NOT USED ALWAYS READ AS 0</b>	<b>NOT USED ALWAYS READ AS 0</b>	<b>RDFLG</b>	<b>VBLANK</b>	<b>LINE ZERO</b>	<b>SPLIT 1</b>	<b>READY</b>	<b>SPLIT 2</b>
		0 = BUSY 1 = READY *	0 = NO 1 = YES	0 = NO 1 = YES	0 = NO 1 = YES	0 = NO 1 = READY	0 = NO 1 = YES

**NOTE:**

\* Status register only. Always 0 when reading interrupt register.

## Advanced Video Display Controller (AVDC)

SCN2674

Descriptions of each interrupt/status register bit follow. Unless otherwise indicated, a bit, once set, will remain set until reset by the CPU by issuing a 'reset interrupt/status bits' command. The bits are also reset by a 'master reset' command and upon power-up.

**Sr[5] — RDFLG**

This bit is present in the status register only. A zero indicates that the AVDC is currently executing the previously issued delayed command. A one indicates that the AVDC is ready to accept a new delayed command. This bit is set to a one upon a master reset.

**I/SR[4] — VBLANK**

Indicates the beginning of a vertical blanking interval. Set to one at the beginning of the first scan line of the vertical front porch.

**I/SR[3] — Line Zero**

Set to one at the beginning of the first scan line (line 0) of each active character row.

**I/SR[2] — Split Screen 1**

This bit is set when a match occurs between the current character row number and the value contained in split register 1, IR12[6:0]. The equality condition is only checked at the beginning of line zero of each character row.

**I/SR[1] — Ready**

The delayed commands affect the display and may require the AVDC to wait for a blanking interval before enacting the command. This bit is set to one when execution of a delayed command has been completed. No other delayed command should be invoked until the prior delayed command is completed. This bit is set to a zero upon a master reset.

**I/SR[0] — Split Screen 2**

This bit is set when a match occurs between the current character row number and the value contained in split register 2 (IR13[6:0]) when you are not scrolling. It is set for the value contained in (split screen register 2) + 1 when scrolling.

**COMMANDS**

The AVDC commands are divided into two classes: the instantaneous commands which are executed immediately after they are invoked, and the delayed commands which may need to wait for a blanking interval prior to their execution. (Command formats are shown in Table 6). The commands are asserted by performing a write operation to the command register with the appropriate bit pattern as the data byte.

**Instantaneous Commands**

The instantaneous commands are executed immediately after the trailing edge of the WR pulse during which the command is issued. These commands do not affect the state of

the RDFLG or READY interrupt/status bits and can be invoked at any time.

**Master Reset**

This command initializes the AVDC and can be invoked at any time to return the AVDC to its initial state. Upon power-up, two successive master reset commands must be applied to release the AVDC's internal power-on circuits. In transparent and shared buffer modes, the CNTRL1 input must be high when the command is issued. The command causes the following:

1. VSYNC and HSYNC are driven low for the duration of the command and BLANK goes high. After command completion, HSYNC and VSYNC will begin operation and BLANK will remain high until a 'display on' command is received.
2. The interrupt and status bits and masks are set to zero, except for the RDFLG flag which is set to a one.
3. The row buffer mode, cursor off, display off, and the line graphics disable states are set.
4. The initialization register pointer is set to address IR0.
5. IR2[7] is reset.

**Load IR Address**

This command is used to preset the initialization register pointer with the value 'V' defined by D3 – D0. Allowable values are 0 to 14.

**Enable Graphics**

After invoking this command, the AVDC will increment the MAC to the next consecutive memory address for each scan line even if more than one scan line per row is programmed. In other words, each scan line begins with a consecutive address from the last displayed address of the previous scan line. This mode can be used for bit-mapped graphics where each location in the display buffer within the defined area contains the bit pattern to be displayed. The graphics mode will be enabled on the next character row after the 'graphics enable' command has been executed. This allows the user to enter and exit graphics mode on character row boundaries.

To perform split screen operations while in graphics mode use SSR2 only.

DADD0/LG is asserted during the trailing edge of BLANK for each scan line while this mode is active.

The AVDC allows up to 128 character rows (initialization register 4) by 256 characters (initialization register 5). For a higher resolution bit mapped screen, the AVDC is programmed as if there are characters and character rows. For example, screen size of  $240 \times 512$  pixels is possible by programming the AVDC for 20 rows with 12 scan lines per

row by 64 characters with 8 dots per character.

In the graphics mode, SSR1 should only be updated during the last scan line of the defined 'character row.'

The bit-mapped graphics mode will work only in the independent and transparent modes.

**Disable Graphics**

Normal addressing resumes at the next row boundary.

**Display Off**

Asserts the BLANK output. The DADD0 through DADD13 display address bus outputs can be optionally placed in the 3-State condition by setting bit 2 to a '1' when invoking the command.

**Display On**

Restores normal blanking operation either at the beginning of the next field (bit 2 = 1) or at the beginning of the next scan line (bit 2 = 0). Also returns the DADD0 – DADD13 drivers to their active state.

**Cursor Off**

Disables cursor operation. Cursor output is placed in the low state.

**Cursor On**

Enables normal cursor operation.

**Reset Interrupt/Status Bits**

This command resets the designated bits in the interrupt and status registers. The bit positions correspond to the bit positions in the registers:

- Bit 0 — Split 2
- Bit 1 — Ready
- Bit 2 — Split 1
- Bit 3 — Line zero
- Bit 4 — Vertical blank

**Disable Interrupts**

Sets the interrupt mask to zeros for the designated conditions, thus disabling these conditions from being set in the interrupt register and asserting the INTR output. Bit position correspondence is as above.

**Enable Interrupts**

This command writes the associated interrupt mask bits to a one. This enables the corresponding conditions to be set in the interrupt register and asserts the INTR output. Bit position correspondence is as above.

**Delayed Commands**

This group of commands is utilized for the independent buffer mode of operation, although the 'increment cursor' command can also be used in other modes. With the exception of the 'write from cursor to pointer' and 'increment cursor' commands, all the commands of this type will be executed immedi-

2

## Advanced Video Display Controller (AVDC)

SCN2674

Table 6. AVDC Command Formats

D7	D6	D5	D4	D3	D2	D1	D0	COMMAND
<b>Instantaneous Commands:</b>								
0	0	0	0	0	0	0	0	Master reset
0	0	0	1	V	V	V	V	Load IR pointer with value V (V = 0 to 14)
0	0	1	d	d	d	1	0 <sup>1</sup>	Disable graphics
0	0	1	d	d	d	1	1 <sup>2</sup>	Enable graphics
0	0	1	d	1	N	d	0 <sup>1</sup>	Display off. Float DADD bus if N = 1
0	0	1	d	1	N	d	1 <sup>2</sup>	Display on: Next field (N = 1) or scan line (N = 0)
0	0	1	1	d	d	d	0 <sup>1</sup>	Cursor off
0	0	1	1	d	d	d	1 <sup>2</sup>	Cursor on
0	1	0	N	N	N	N	N	Reset interrupt/status: Bit reset where N = 1
1	0	0	N	N	N	N	N	Disable interrupt: Disable where N = 1
0	1	1	N	N	N	N	N	Enable interrupt: Enables interrupts where N = 1
			V	L	S	R	S	<b>Interrupt Bit Assignments</b>
			B	Z	P	D	P	
					1	Y	2	
<b>Delayed Commands:</b>								<b>Hex</b>
1	0	1	0	0	1	0	0	A4 Read at pointer address
1	0	1	0	0	0	1	0	A2 Write at pointer address
1	0	1	0	1	0	0	1	A9 Increment cursor address
1	0	1	0	1	1	0	0	AC Read at cursor address
1	0	1	0	1	0	1	0	AA Write at cursor address
1	0	1	0	1	1	0	1	AD Read at cursor address and increment address
1	0	1	0	1	0	1	1	AB Write at cursor address and increment address
1	0	1	1	1	0	1	1	BB Write from cursor address to pointer address
1	0	1	1	1	1	0	1	BD Read from cursor address to pointer address

**NOTES:**

- Any combination of these three commands is valid.
- Any combination of these three commands is valid.
- d = don't care.
- No additional circuit required if read latch is implemented using 74LS374.

ately or will be delayed depending on when the command is invoked. If invoked during the active screen time, the command is executed at the next horizontal blanking interval. If invoked during a vertical retrace interval or a 'display off' state, the command is executed immediately.

The 'increment cursor' command is executed immediately after it is issued and requires approximately three  $\overline{CCLK}$  periods for completion. The 'write from cursor to pointer' command executes during blanking intervals. The AVDC will execute as many writes as possible during each blanking interval. If the command is not completed during the current blanking interval, the command will be held in

suspension during the next active portion of the screen and continues during the next blanking interval until the command is completed.

In all cases, the AVDC will assert the READY/RDFLG status to signify completion of the delayed command. No other delayed command should be given until the previous delayed command has completed. Therefore, the READY interrupt or RDFLG status flag should be used for handshaking control between the AVDC and CPU when using the delayed commands.

**Read/Write at Pointer**

Transfers data between the display buffer and the bus interface latch using the address contained in the pointer registers.

**Read/Write at Cursor**

Transfers data between the display buffer and the bus interface latch using the address contained in the cursor registers.

**Increment Cursor**

Adds one (modulo 16k) to the cursor address registers. Also note that in place of "increment cursor" command, "Read/Write at cursor and increment" command may be used.

**Read/Write at Cursor and Increment**

Transfers data between the display buffer and the bus interface latch using the address contained in the cursor registers and then adds one (modulo 16k) to the cursor address registers.

**Write from Cursor to Pointer**

Writes the data contained in the bus interface latch into the block of display memory designated by the cursor address and pointer address registers, inclusive. After completion of the command, the pointer address will be unchanged, but the cursor register contents will be equal to the pointer address.

**Read from Cursor to Pointer**

Writes the data from the block of display memory designated by the cursor and pointer addresses inclusive into the bus interface latch. This command can be used for a DMA dump of memory into RAM from the cursor location to the pointer location. After completion of the command, the cursor register contents will equal the pointer register contents.

## Advanced Video Display Controller (AVDC)

SCN2674

ABSOLUTE MAXIMUM RATINGS<sup>1</sup>

SYMBOL	PARAMETER	RATING	UNIT
T <sub>A</sub>	Operating ambient temperature <sup>2</sup>	0 to +70	°C
T <sub>STG</sub>	Storage temperature range	-65 to +150	°C
	All voltages with respect to ground <sup>3</sup>	-0.5 to +6.0	V

DC ELECTRICAL CHARACTERISTICS T<sub>A</sub> = 0°C to +70°C, V<sub>CC</sub> = +5.0V ± 5%<sup>4, 5, 6</sup>

SYMBOL	PARAMETER	TEST CONDITIONS	LIMITS			UNIT
			Min	Typ	Max	
V <sub>IL</sub>	Input low voltage	I <sub>OL</sub> = 2.4mA I <sub>OH</sub> = -200μA	2		0.8	V
V <sub>IH</sub>	Input high voltage					V
V <sub>OL</sub>	Output low voltage					V
V <sub>OH</sub>	Output high voltage (except INTR output)					V
I <sub>IL</sub>	Input leakage current	V <sub>IN</sub> = 0 to V <sub>CC</sub>	-10		10	μA
I <sub>LL</sub>	Data bus 3-State leakage current	V <sub>O</sub> = 0 to V <sub>CC</sub>	-10		10	μA
I <sub>OD</sub>	INTR open drain output leakage current	V <sub>O</sub> = 0 to V <sub>CC</sub>			10	μA
I <sub>CC</sub>	Power supply current				185	mA

2

## Advanced Video Display Controller (AVDC)

SCN2674

AC ELECTRICAL CHARACTERISTICS  $T_A = 0^\circ\text{C}$  to  $+70^\circ\text{C}$ ,  $V_{CC} = +5.0\text{V} \pm 5\%$ <sup>4, 5, 6, 7</sup>

SYMBOL	PARAMETER	TEST CONDITIONS <sup>8</sup>	2.7MHz		4.0MHz		UNIT
			Min	Max	Min	Max	
<b>Bus timing (Figure 18)<sup>9</sup></b>							
t <sub>AS</sub>	A0 – A2 setup time to $\overline{WR}$ , $\overline{RD}$ low		30		30		ns
t <sub>AH</sub>	A0 – A2 hold time from $\overline{WR}$ , $\overline{RD}$ high		0		0		ns
t <sub>CS</sub>	$\overline{CE}$ setup time to $\overline{WR}$ , $\overline{RD}$ low		0		0		ns
t <sub>CH</sub>	$\overline{CE}$ hold time from $\overline{WR}$ , $\overline{RD}$ high		0		0		ns
t <sub>rw</sub>	$\overline{WR}$ , $\overline{RD}$ pulse width		250		200		ns
t <sub>DD</sub>	Data valid after $\overline{RD}$ low			200		200	ns
t <sub>DF</sub>	Data bus floating after $\overline{RD}$ high			100		100	ns
t <sub>DS</sub>	Data setup time to $\overline{WR}$ high		150		150		ns
t <sub>DH</sub>	Data hold time from $\overline{WR}$ high		10		5		ns
t <sub>CC</sub>	High time from $\overline{CE}$ to $\overline{CE}$						ns
	Consecutive commands		t <sub>CCP</sub>		t <sub>CCP</sub>		ns
	Other accesses		300		300		ns
<b>CCLK timing (Figures 19, 20, 21)</b>							
t <sub>CCP</sub>	CCLK period		370	10,000	250	10,000	ns
t <sub>CCH</sub>	CCLK high time		125		100		ns
t <sub>CCL</sub>	CCLK low time		125		100		ns
	Output delay from CCLK edge <sup>11</sup>						ns
t <sub>CCD1</sub>	DADD0 – 13, MBC		40	175	40	150	ns
t <sub>CCD2</sub>	BLANK, HSYNC, VSYNC/CSYNC, CURSOR, BEXT, BREQ, BACK, BCE, WDB, RDB <sup>10</sup>		40	225	40	200	ns
<b>Other timings (Figure 20)</b>							
t <sub>RDL</sub>	READY/RDFLG low from $\overline{WR}$ high <sup>9</sup>			t <sub>CCP</sub> + 30		t <sub>CCP</sub> + 30	ns
t <sub>BAK</sub>	BACK high from PBREQ low			225		200	ns
t <sub>BXT</sub>	BEXT high from PBREQ high			225		200	ns
t <sub>IRL</sub>	INTR low from CCLK low			225		200	ns
t <sub>IRH</sub>	INTR high from $\overline{WR}$ , $\overline{RD}$ high <sup>9</sup>			600		600	ns
t <sub>AC</sub>	ACLL from HSYNC		3 × t <sub>CCP</sub>		3 × t <sub>CCP</sub>		ns
<b>Row table input timing (Figure 21)</b>							
t <sub>DSRT</sub>	Data setup time to CCLK low		100		60		ns
t <sub>DHRT</sub>	Data hold time from CCLK low		60		60		ns

## NOTES:

- Stresses above those listed under Absolute Maximum Ratings may cause permanent damage to the device. This is a stress rating only and functional operation of the device at these or at any conditions above those in the operation section of this specification is not implied.
- For operating at elevated temperatures, the device must be derated based on  $+150^\circ\text{C}$  maximum junction temperature.
- This product includes circuitry specifically designed for the protection of its internal devices from damaging effects of excessive static charge. Nonetheless, it is suggested that conventional precautions be taken to avoid applying any voltages larger than the rated maxima.
- Parameters are valid over specified temperature range.
- All voltage measurements are referenced to ground (GND).
- Typical values are at  $+25^\circ\text{C}$ , typical supply voltages, and typical processing parameters.
- For testing, all input signals swing between 0.4V and 2.4V with a transition time of 20ns maximum. All time measurements are referenced at input voltages of 0.8V and 2.0V and output voltages of 0.8V and 2.0V as appropriate.
- Test condition for outputs:  $C_L = 150\text{pF}$ .
- Timing is illustrated and specified referenced to  $\overline{WR}$  and  $\overline{RD}$  inputs. Device may also be operated with  $\overline{CE}$  as the 'strobing' input. In this case, all timing specifications apply referenced to falling and rising edges of  $\overline{CE}$ .
- BCE, WDB, and RDB delays track each other within 10ns. Also, these output delays will tend to follow direction (min/max) of DADD0 – 13 delays.
- These values were measured with a capacitance load of 150pF. To adjust the output delay, use the following correction factor:  $50\text{pF} \leq C_L < 150\text{pF}$ :  $-0.15\text{ns/pF}$ .



Advanced Video Display Controller (AVDC)

SCN2674

2

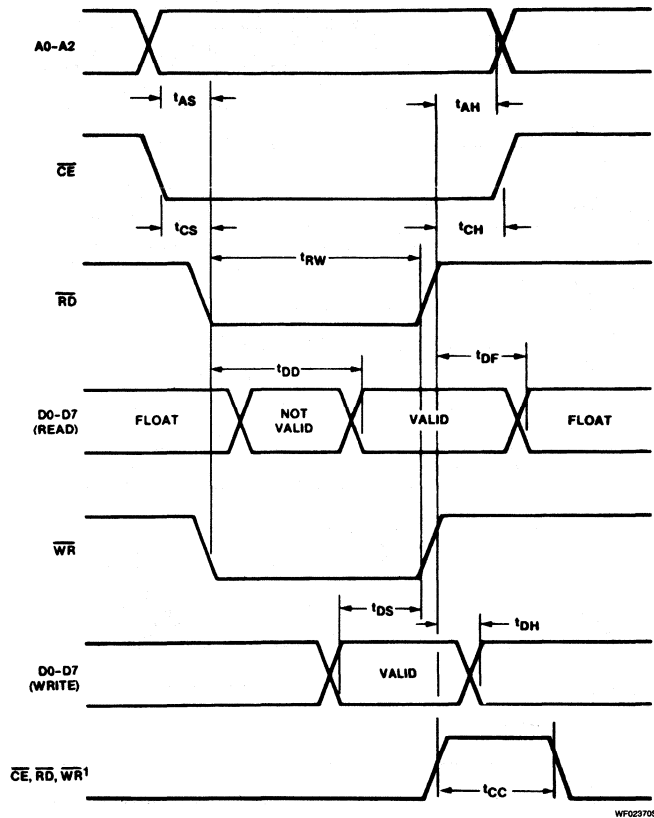

WF023705

**NOTE:**  
1. Any two must be high for  $t_{CC}$ .

Figure 18. Bus Timing

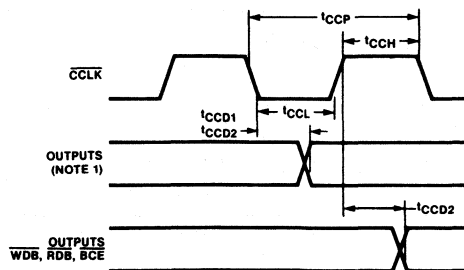

WF023805

**NOTES:**  
1. DADD0 - DADD13, BLANK, HSYNC, CSYNC/VSYNC, CURSOR, BEXT, BREO, BCE, MBC, BACK.  
2. BCE changes state on both CCLK edges — (see Figures 3 and 4).

Figure 19. CCLK Timing

Advanced Video Display Controller (AVDC)

SCN2674

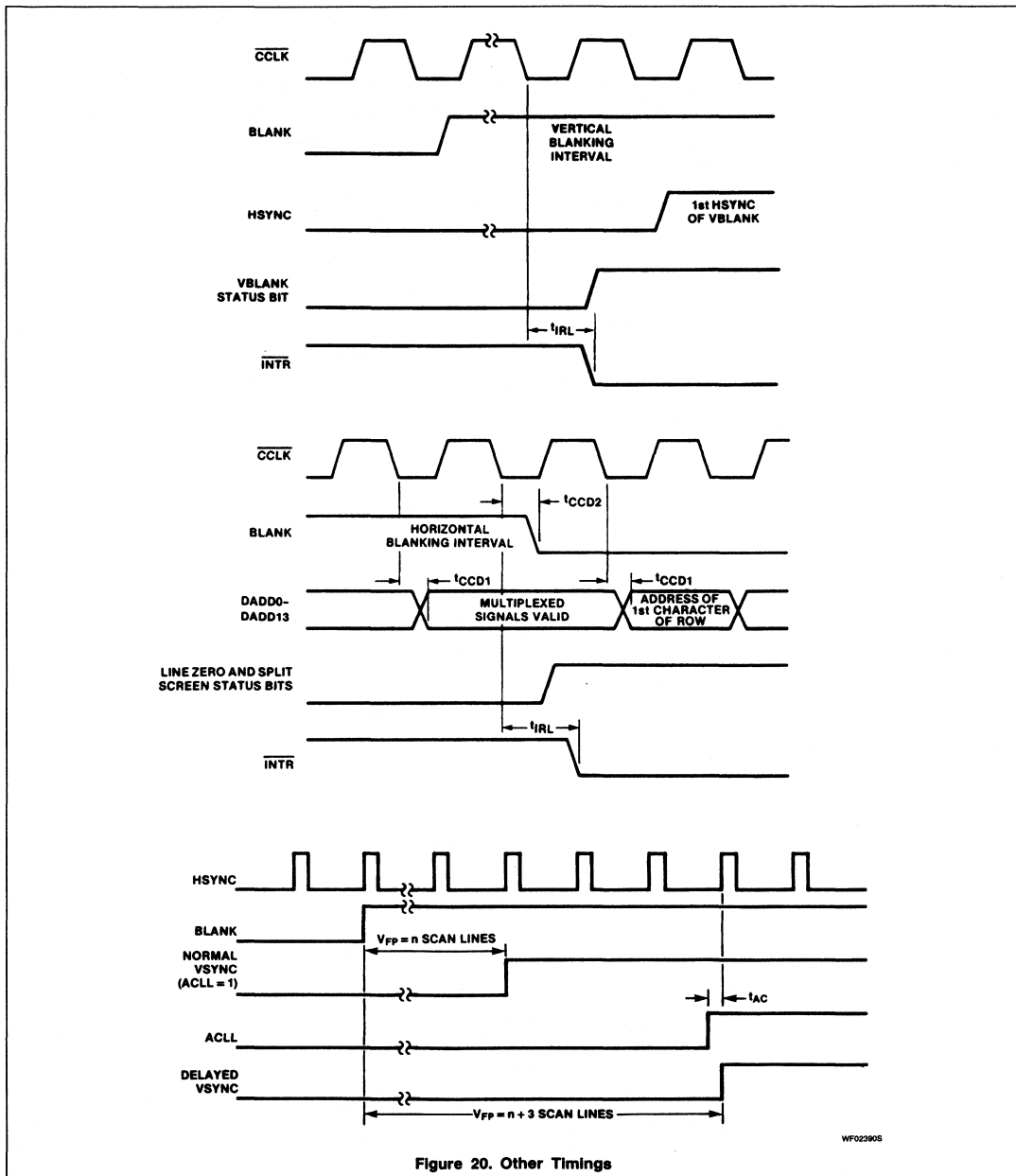

Advanced Video Display Controller (AVDC)

SCN2674

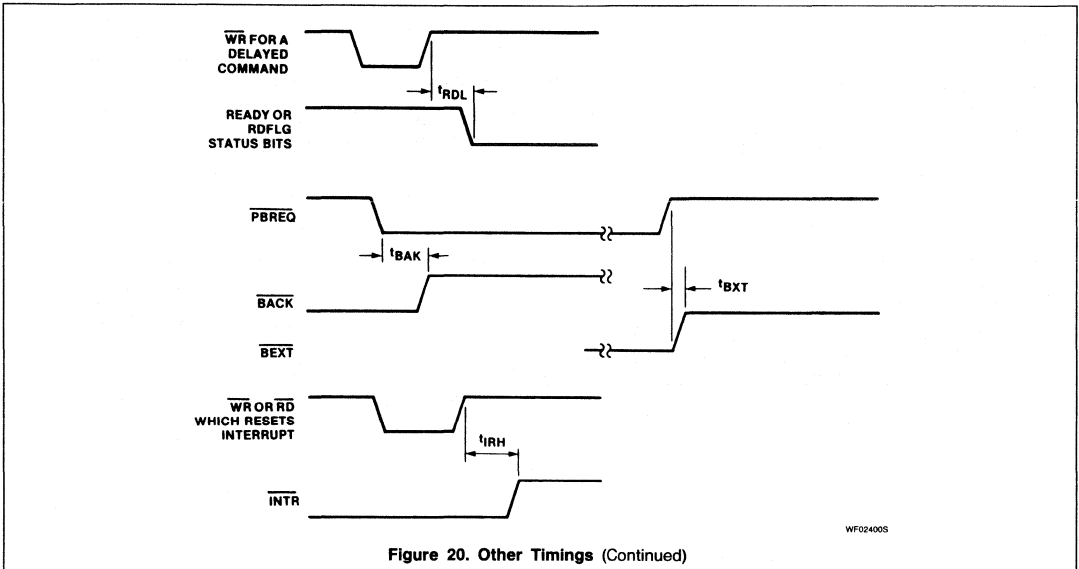

Figure 20. Other Timings (Continued)

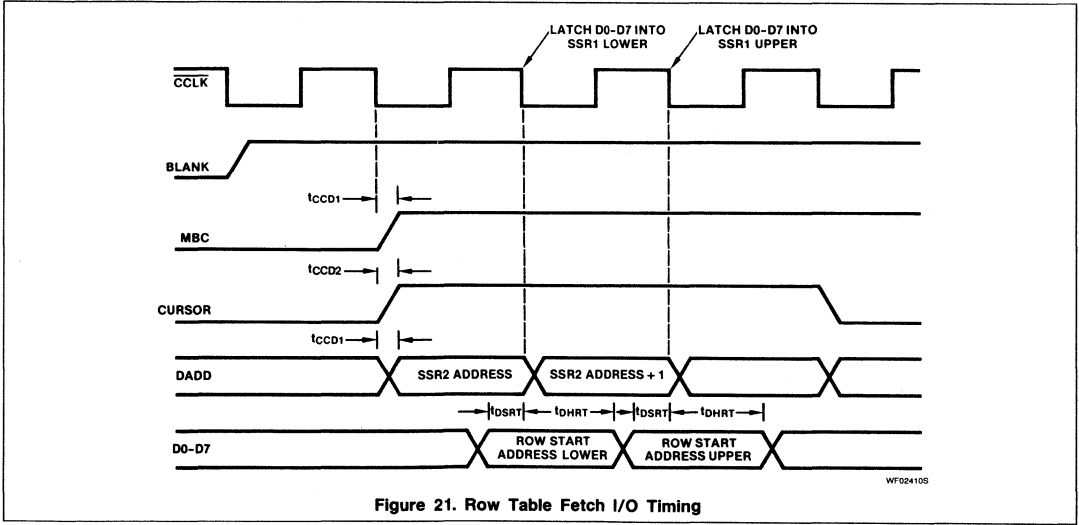

Figure 21. Row Table Fetch I/O Timing

Advanced Video Display Controller (AVDC)

SCN2674

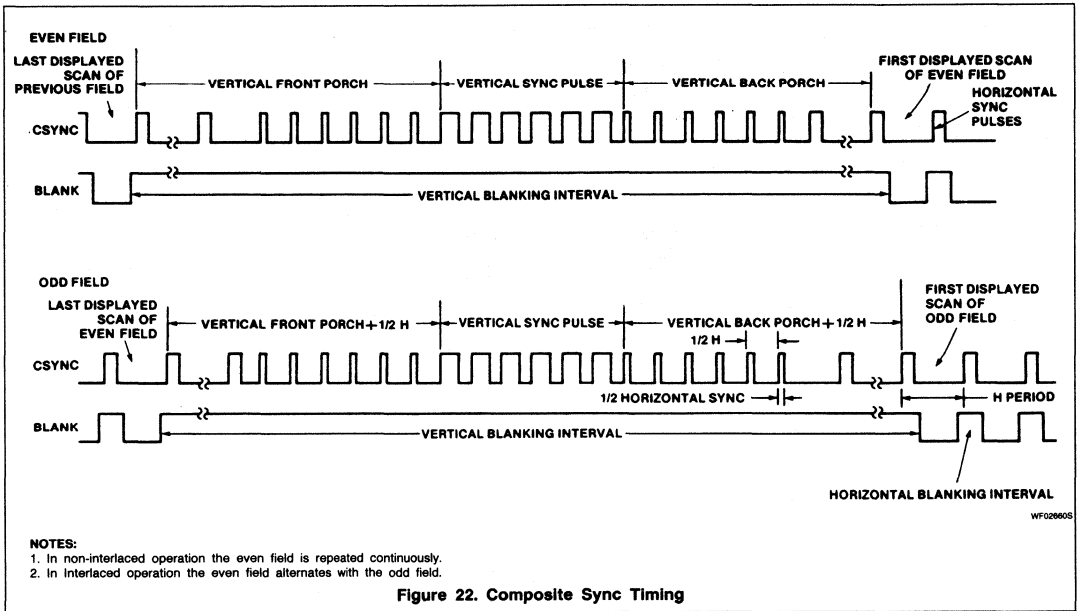

Figure 22. Composite Sync Timing

# SCB2675

## Color/Monochrome Attributes Controller (CMAC)

Product Specification

### Microprocessor Products

#### DESCRIPTION

The Signetics SCB2675 Color/Monochrome Attributes Controller (CMAC) is a bipolar LSI device designed for CRT terminals and display systems that employ raster scan techniques. It contains a programmable dot clock divider to generate a character clock; a high-speed shift register to serialize input dot data into a video stream; latches and logic to apply visual attributes to the resulting display; and logic to display a cursor on the display.

The CMAC provides control of visual attributes on a character-by-character basis for two operating modes: monochrome and color. The monochrome mode provides reverse video, blank, highlight and two general purpose user-definable attributes. In this mode, the display characters can be specified to appear on either a light or dark screen background. Retrace video suppression can be automatically or externally controlled. The color mode provides eight colors for foreground (character) video and eight colors for background video together with a luminance output for external color set selection, or to simultaneously drive a monochrome monitor. Additionally, both modes provide double width, underline, blink, dot stretching and dot width attributes. In monochrome mode, the SCB2675 emulates the attribute characteristics of Digital Equipment Corporation's VT100 terminal.

The horizontal dot frequency is the basic timing input to the CMAC. This clock is divided internally to provide a character clock output for system synchronization. Up to nine bits of dot data are parallel loaded into the video shift register on each character boundary. The two TTL video data outputs in monochrome mode are encoded to provide four video intensities (black, gray, white and high-light). The video data in color mode is encoded to provide eight foreground colors and shifted out on three TTL outputs, together with the luminance output.

#### FEATURES

- 25MHz and 18MHz video dot rate versions\*
- Four video intensities encoded on two TTL outputs (monochrome mode)
- Eight foreground and background colors encoded on three TTL outputs (color mode)
- Internally latched character attributes:
  - Reverse video
  - Blank
  - Blink
  - Underline
  - Highlight
  - Two general purpose
  - Eight foreground colors
  - Eight background colors
  - Dot width control
  - Double width characters
- VT100 compatible attributes
- Reverse video cursor with optional white cursor in color mode
- Up to 10 dots per character
- Light or dark background in monochrome mode
  - Automatic retrace blanking
- Programmable dot stretching
- Compatible with SCN2674 AVDC and SCN2670 DCGG
- TTL compatible
- 40-pin dual-in-line package

#### APPLICATIONS

- CRT terminals
- Word processing systems
- Small business computers

\*40MHz SCB2675T also available.

#### PIN CONFIGURATIONS

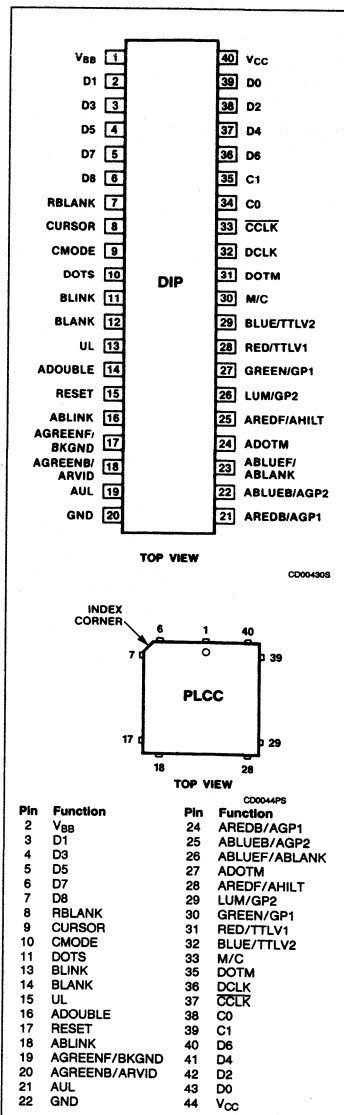

# Color/Monochrome Attributes Controller (CMAC)

## SCB2675

### ORDERING INFORMATION

PACKAGES	DOTS PER CHARACTER	V <sub>CC</sub> = +5V ± 5%, 0°C to +70°C	
		25MHz	18MHz
Ceramic DIP Plastic DIP Plastic LCC	7, 8, 9, 10	SCB2675BC5I40 SCB2675BC5N40 SCB2675BC5A44	SCB2675BC8I40 SCB2675BC8N40 SCB2675BC8A44
Ceramic DIP Plastic DIP Plastic LCC	6, 8, 9, 10	SCB2675CC5I40 SCB2675CC5N40 SCB2675CC5A44	SCB2675CC8I40 SCB2675CC8N40 SCB2675CC8A44

### BLOCK DIAGRAM

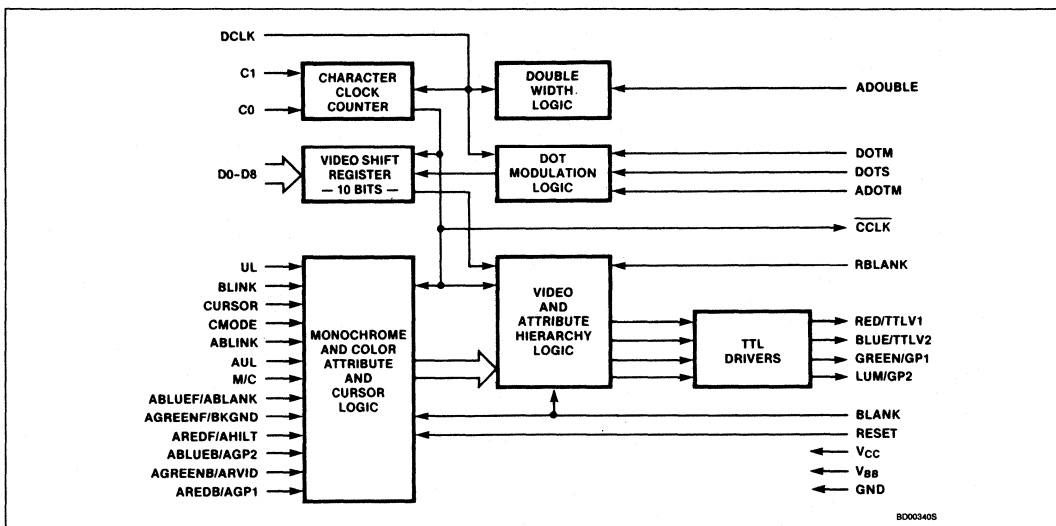

## Color/Monochrome Attributes Controller (CMAC)

SCB2675

## PIN DESCRIPTION

MNEMONIC	PIN NO.		TYPE	NAME AND FUNCTION
	DIP	PLCC		
V <sub>CC</sub>	40	44	I	<b>Power supply:</b> +5V ±5%
V <sub>BB</sub>	1	2	I	<b>Bias Supply:</b> See Figure 5
GND	20	22	I	<b>Ground:</b> 0V reference
DCLK	32	36	I	<b>Dot Clock:</b> Dot frequency input. Video output shift rate.
CCLK	33	37	O	<b>Character Clock:</b> An output which is a submultiple of DCLK. The period ranges from 6 to 10 DCLK periods per cycle and is determined by the state of the C0, C1 inputs.
RED/TTLV1	28	31	O	<b>Red/TTL Video 1:</b> In color mode, this output provides the red gun serial video. In monochrome mode, it should be used with the blue/TTL video 2 output to decode four video intensities.
BLUE/TTLV2	29	32	O	<b>Blue/TTL Video 2:</b> In color mode, this output provides the blue gun serial mode. In monochrome mode, it should be used with the red/TTL video 1 output to decode four video intensities.
GREEN/GP1	27	30	O	<b>Green/General Purpose 1:</b> In color mode, this output provides the green gun serial video. In monochrome mode, it is a general purpose TTL output which is asserted if the AREDB/AGP1 input is asserted when the corresponding character dot data is loaded into the video shift register. GP1 can be active in either active scan or blank time.
LUM/GP2	26	29	O	<b>Luminance/General Purpose 2:</b> In color mode, this output is the logical-OR of the RGB foreground video. It is low during a blanking interval and during the foreground portion of the cursor display. In monochrome mode, it is a general purpose TTL output which is asserted if the ABLUEB/AGP2 input is asserted when the corresponding character dot data is loaded into the video shift register. GP2 can be active in either active scan or blank time.
UL	13	15	I	<b>Underline Timing:</b> Indicates the scan line(s) for the underline attribute. Latched on the falling edge of BLANK. The underline will be displayed on the specified scan line for every character where AUL = 1.
BLINK	11	13	I	<b>Blink Timing:</b> This input is sampled on the falling edge of BLANK to provide the blink rate for the blink attribute. Should be a submultiple of the frame rate.
BLANK	12	14	I	<b>Screen Blank:</b> When high, this input forces the video outputs to the specified background color in color mode and to the level specified by the BKGND input (either black or gray) in monochrome mode.
RBLANK	7	8	I	<b>Retrace Blank:</b> This input is used to force the video outputs to a low during retrace periods. If pulled high, it will automatically suppress video during the retrace periods when BLANK is high. The user may also pulse this input while BLANK is high to selectively suppress raster video.
AGREENF/BKGND	17	19	I	<b>Green Foreground/Background Intensity:</b> In color mode, this input activates the GREEN/GP1 output during the foreground (character video) portion of the associated character block. In monochrome mode, this input specifies gray or black screen background.
ABLUEF/ABLANK	23	26	I	<b>Blue Foreground/Blank Attribute:</b> In color mode, this input activates the BLUE/TTLV2 output during the foreground (character video) portion of the associated character block. In monochrome mode, this input generates a blank space for the associated character. The blank space intensity is controlled by the AGREENF/BKGND input, the reverse video attribute and cursor input.
AREDF/AHILT	25	28	I	<b>Red Foreground/Highlight Attribute:</b> In color mode, this input activates the RED/TTLV1 output during the foreground (character video) portion of the associated character block. In monochrome mode, this input highlights the associated character (including underline).
CURSOR	8	9	I	<b>Cursor Timing:</b> This input provides the timing for the cursor video. In color mode, with CURSOR and CMODE high, the RGB outputs are driven high (white cursor). If CMODE is low, or in monochrome mode, this input reverses the intensities of the video and attributes (the foreground and background intensities are reversed). Cursor position, shape, and blink rate are controlled by this input.
CMODE	9	10	I	<b>Cursor Mode:</b> Used in color mode only. When CURSOR and CMODE are high, the RGB outputs are driven high (white cursor). When CURSOR is high and CMODE is low, the RGB outputs are logically inverted (reverse video cursor).
AUL	19	21	I	<b>Underline Attribute:</b> Specifies a line to be displayed in the character block. The specific line(s) are specified by the UL input. All other attributes apply to the underline video.
ABLANK	16	18	I	<b>Blink Attribute:</b> In color mode, this active high input will drive the foreground RGB combination to the background RGB combination. In monochrome mode, the associated character or background is driven to the intensity determined by BKGND, reverse video attribute and the cursor input.

## Color/Monochrome Attributes Controller (CMAC)

SCB2675

## PIN DESCRIPTION (Continued)

MNEMONIC	PIN NO.		TYPE	NAME AND FUNCTION
	DIP	PLCC		
ADDOUBLE	14	16	I	<b>Double Width Attribute:</b> This active high input causes the associated character video to be shifted out of the serial shift register at one half the dot frequency (DCLK). The CCLK output is not affected.
AREDB/ AGP1	21	24	I	<b>Red Background/General Purpose Attribute 1:</b> In color mode, this input activates the RED/TTLV1 output during the background portion of the associated character block. In monochrome mode, it activates the GREEN/GP1 output for the associated character block.
ABLUEB/ AGP2	22	25	I	<b>Blue Background/General Purpose Attribute 2:</b> In color mode, this input activates the BLUE/TTLV2 output during the background portion of the associated character block. In monochrome mode, it activates the LUM/GP2 output for the associated character block.
AGREENB/ ARVID	18	20	I	<b>Green Background/Reverse Video Attribute:</b> In color mode, this input activates the GREEN/GP1 output during the background portion of the associated character block. In monochrome mode, it causes the associated character block video intensities to be reversed.
D0 - D8	39, 2, 38, 3, 37, 4, 36, 5, 6	43, 3, 42, 4, 41, 5, 40, 6, 7	I	<b>Dot Data Input:</b> These are parallel inputs corresponding to the character/graphic symbol dot data for a given scan line. These inputs are strobed into the video shift register on the trailing (falling) edge of each character clock (CCLK).
C0, C1	34, 35	38, 39	I	<b>Character Clock Control:</b> The states of these two static inputs determine the internal divide factor for the CCLK output rate.
RESET	15	17	I	<b>Reset:</b> This active high input initializes the internal logic and resets the attribute latches.
M/C	30	33	I	<b>Monochrome/Color Mode:</b> This input selects whether the CMAC operates in monochrome or color mode. A low selects color mode and a high selects monochrome mode.
ADOTM	24	27	I	<b>Dot Modulation Attribute:</b> When DOTM and this input are high, the active dot width of the associated character video is one DCLK. When DOTM is high and this input is low, the active dot width of the associated character video is two DCLKs.
DOTM	31	35	I	<b>Dot Width Modulation:</b> When this input is high, two DCLKs are used for each dot shifted through the shift register. When this input is low, one DCLK is used.
DOTS	10	11	I	<b>Dot Stretching:</b> Sampled at the falling edge of BLANK. When this input is high, one extra dot is appended to individual dots or groups of dots of the input parallel data and then transferred through the shift register. When this input is low, normal transfer of input parallel data results.

## FUNCTIONAL DESCRIPTION

The CMAC consists of seven major sections (see block diagram). The high-speed dot clock input is applied to a programmable divider to provide a character clock output for system timing. Parallel dot data is loaded into the video shift register on character boundaries and shifted into the video logic block at the dot rate specified by the dot modulation section. The appropriate attribute control inputs are selected by the mode select logic, latched internally on character boundaries, and combined with the serial dot data to provide monochrome or color video outputs.

The BLANK input defines the active screen and retrace areas. In color mode, the video outputs are forced to the specified background color when this signal is asserted; in monochrome mode the video outputs are forced to the states defined by the BKGND input, i.e., black if dark background is selected and gray if light background is selected. A separate RBLANK input allows the user to select the amount of border around the active area when operating in color mode or in monochrome mode with light background.

Table 1. Monochrome Mode Attribute Characteristics

REV <sup>1</sup>	AHILT	ABLANK <sup>2</sup>	FOREGROUND VIDEO	BACKGROUND VIDEO
0	0	0	W	B
0	0	1	W/G	B
0	1	0	H	B
0	1	1	H/W	B
1	0	0	B	G
1	0	1	B/W	G/B
1	1	0	B	W
1	1	1	B/H	W/B

## NOTES:

- REV = (BKGND) XOR (ARVID):

BKGND	ARVID	REV
0	0	0
0	1	1
1	0	1
1	1	0
- For blinking, the video outputs are shown as 0/1, where 0 and 1 are the blink timing input states.
- Foreground includes underline when underlining is specified by AUL = 1.
- When ABLANK = 1, foreground component becomes same as background component.
- Codes for video outputs are as follows:

CODE	TTLV2	TTLV1	BEAM INTENSITY
B	0	0	Black (B)
G	0	1	Gray (G)
W	1	0	White (W)
H	1	1	Highlight (H)



## Color/Monochrome Attributes Controller (CMAC)

SCB2675

2

This input can be tied high, in which case the area outside the active area will be dark, or it may be pulsed during BLANK periods to externally control the border widths.

In color mode, eight colors for the character (foreground) and eight colors for the background (area other than character) can be selected by the attribute inputs. In monochrome mode, the intensities of foreground and background are a function of the attribute and BKGND inputs, i.e., characters may be black, gray, white, or highlight (very white) while background may be black, gray, or white (see Table 1).

### Character Clock Counter

The character clock counter divides the DCLK input to generate the character clock (CCLK). The divide factor is specified by the clock control inputs (C1, C0) as follows:

SCB2675B			
C1	C0	Dots/ Char.	CCLK Duty Cycle*
		0	0
0	1	7	3/4
1	0	8	4/4
1	1	9	4/5

#### NOTE:

\*High/low

SCB2675C			
C1	C0	Dots/ Char.	CCLK Duty Cycle*
		0	0
0	1	6	3/3
1	0	8	4/4
1	1	9	4/5

#### NOTE:

\*High/low

The number of dot clocks/character is normally the number of dots/character as listed above. However, when dot width control is specified, the DCLK input is divided by two before it is applied to the character clock counter resulting in the number of dot clocks/character being double those listed above, although the number of displayed dots/character remains the same. The number of dots per character (C1, C0) can be dynamically changed on either edge of the character clock as shown in Figure 10 (See Dot Modulation Logic).

### Video Shift Register

On each character boundary, the parallel input dot data (D0–D8) is loaded into the video shift register. The data is shifted out least significant bit first (D0) at the DCLK rate. If 10 dots/character are specified (C1, C0 = 00), the tenth dot will be the same as

D8. The serial dot data from the video shift register is routed to the video logic where it is combined with the cursor and attribute control bits to produce the video data outputs.

### Mode Select, Attribute And Cursor Control

The mode select logic multiplexes the monochrome and color attribute inputs and outputs as specified by the M/C input. The monochrome mode provides blank, reverse video, highlight and two general purpose attributes. The latter may be used, with external logic, to combine other attributes (e.g., overscore) into the video stream. The color mode provides RGB foreground and background color attributes. Both modes provide double width characters, blink, underline, dot width control and dot stretching.

The cursor and attribute inputs are pipelined internally to allow for system pipeline propagations. The cursor input and the attribute inputs are delayed for one CCLK to account for the delay of the character data through the character generator latches. The attribute timing inputs (BLINK, UL and DOTS) are clocked into the 2675 at the beginning of each scan line time by the falling edge of BLANK. Thus, these inputs must be in their proper state at the falling edge of BLANK preceding the scan line where they are required to be active. The BLANK signal itself is also delayed internally to provide for the RAM and character generator delays (see Figures 6 and 7). Internal delays cause the video outputs to be delayed relative to CCLK as illustrated in Figure 8.

### Video Logic

Each character block consists of the three components shown in Figure 1. Symbol video is generated from the dot data inputs D0–D8. Underline video is enabled by the AUL attribute and is generated during the scan lines for which the UL input is active. Underline and symbol video are always the same intensity or color, and other attributes (e.g., ABLINK) apply to them equally. The combination of underline and symbol video is also referred to as foreground video. Background video is the area of the character block corresponding to the absence of foreground video. The assertion of the non-display attribute in the monochrome mode (ABLANK) causes the entire character block to be displayed as background.

In monochrome mode, the serial dot data and pipelined cursor and attributes are combined to generate four video intensities (black, gray, white and highlight) which are encoded on the TTLV1 and TTLV2 outputs as follows:

TTLV2	TTLV1	VIDEO INTENSITY
0	0	Black
0	1	Gray
1	0	White
1	1	Highlight

Table 1 describes the relationship between attributes and video intensity of the foreground and background components of the character block in monochrome mode.

In color mode, the colors of the foreground and background components are specified by the corresponding attribute inputs; AREDF, AGREENF and ABLUEF dictate the color of the foreground component while AREDB, AGREENB and ABLUEB do the same for the background component. In this mode, the serial dot data and pipelined cursor and attributes are combined to generate four video outputs. The RED, GREEN and BLUE outputs separately contain the corresponding foreground and background components. The LUM output is the logical-OR of the foreground colors and can be used to drive a separate monochrome monitor or to select a different set of colors for the foreground.

### Dot Modulation Logic

The dot modulation logic controls the video shift register to supply dot stretching and dot width control.

Dot stretching is controlled by the DOTS input which is sampled by each scan line at the trailing (falling) edge of BLANK. If DOTS is asserted at that time, all characters on the following scan line will have dot stretching applied. Dot stretching causes an extra dot to be added to individual dots or groups of dots as shown in Figures 2 and 3. Dot stretching also can be used to:

1. Compensate for low video bandwidth monitors (since the minimum active displayed segment with dot stretching is two DCLKs).
2. Assure crisp black characters when operating in white background mode.
3. Provide thick characters as a means of distinguishing areas of the display.

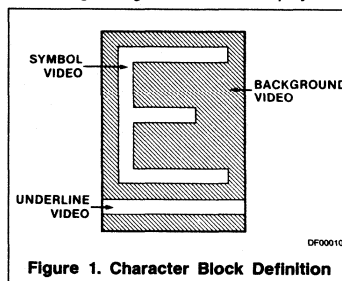

Figure 1. Character Block Definition

# Color/Monochrome Attributes Controller (CMAC)

SCB2675

Dot width is controlled by the DOTM and ADOTM inputs. DOTM is tied either high, which enables the feature on the entire display, or low, which disables the feature. With ADOTM high, the dot width of characters can be selectively controlled by assertion of the ADOTM attribute input. When operating in this mode, the dot clock input is divided by two before being applied to other circuits in the CMAC. The CCLK output is also divided by two.

The truth table for the possible combinations of ADOTM and DOTM is as follows:

ADOTM	DOTM	OPERATION
0	0	Normal mode
0	1	Dot width control, 100% duty cycle (DCLK ÷ 2, CCLK ÷ 2)
1	0	Not allowed
1	1	Dot width control, 50% duty cycle (DCLK ÷ 2, CCLK ÷ 2)

When dot width control is enabled as above, two DCLKs are used for each video dot period. Asserting ADOTM for a particular character will cause each active video dot of the displayed character to be turned on for one DCLK and off for the other DCLK, while if ADOTM is negated for that character, the active video dot for that character will be turned on (black background) or off (white background) for both DCLK times (see Figures 2 and 4). Only the character video component of the character block is modulated. Underline video and background are not affected by ontime modulation. Width control can be used to:

1. Make horizontal lines and vertical lines appear the same brightness on the display.
2. Provide two different brightness levels for characters without requiring a monitor with analog brightness inputs.

However, note that the effects produced by this feature are highly dependent on the video amplifier characteristics of the monitor used.

### Double Width Logic

The double width logic controls the rate at which dots are shifted through the video shift register. When the ADOUBLE input is asserted, the associated character video will be shifted at one half the DCLK rate, and the dot information for the next character will be loaded into the shift register two CCLKs later. The character and attribute data that is present on the first CCLK after the ADOUBLE input is asserted will be ignored. The CCLK output is not affected. If a double width character is specified at the last location of a character row, the second half of the double width character (one CCLK) will extend into the horizontal front porch.

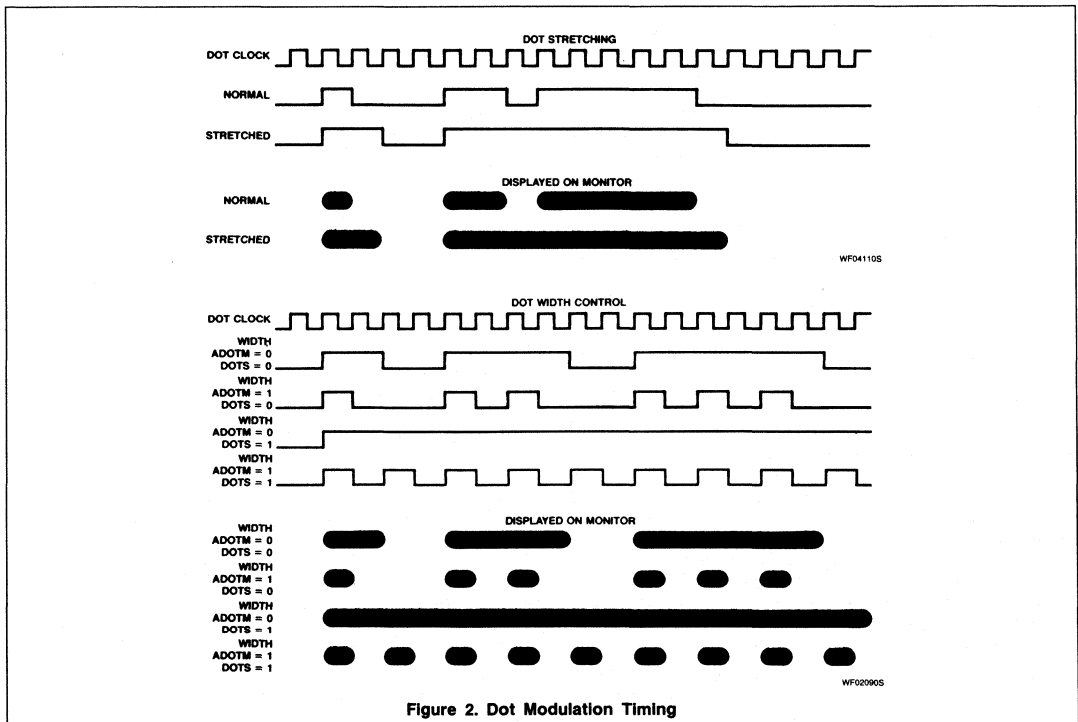

Figure 2. Dot Modulation Timing

# Color/Monochrome Attributes Controller (CMAC)

SCB2675

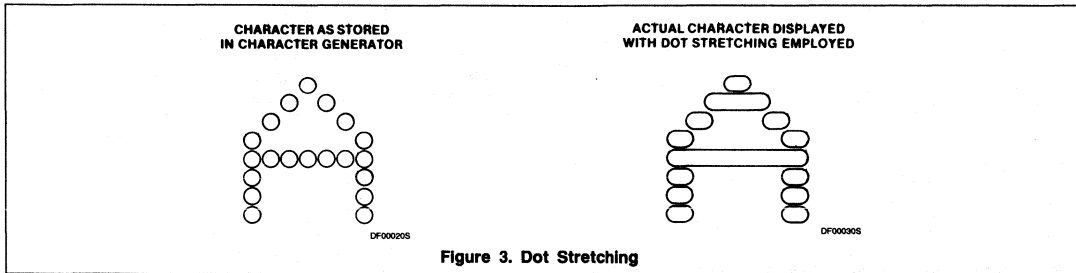

Figure 3. Dot Stretching

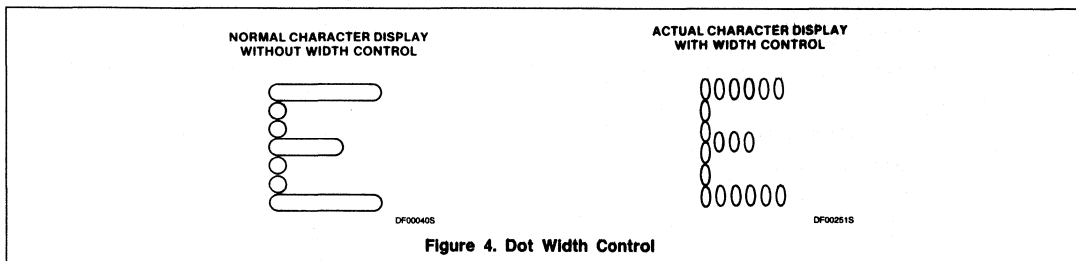

Figure 4. Dot Width Control

## ABSOLUTE MAXIMUM RATINGS<sup>1</sup>

SYMBOL	PARAMETER	RATING	UNIT
T <sub>A</sub>	Operating ambient temperature <sup>2</sup> range	0 to +70	°C
T <sub>STG</sub>	Storage temperature range	-65 to +150	°C
	All voltages with respect to ground <sup>3</sup>	-0.5 to +6.0	V

## DC ELECTRICAL CHARACTERISTICS T<sub>A</sub> = 0°C to +70°C, V<sub>CC</sub> = +5V ± 5%, V<sub>BB</sub> = Figure 5<sup>4, 5</sup>

SYMBOL	PARAMETER	TEST CONDITIONS	LIMITS			UNIT
			Min	Typ	Max	
V <sub>IL</sub>	Input low voltage	I <sub>OL</sub> = 4mA I <sub>OH</sub> = -400µA	2		0.8	V
V <sub>IH</sub>	Input high voltage					
V <sub>OL</sub>	Output low voltage				0.4	V
V <sub>OH</sub>	Output high voltage					V
I <sub>IL</sub>	Input low current DCLK	V <sub>IN</sub> = 0.4V			-800	µA
I <sub>IH</sub>	All other inputs	V <sub>IN</sub> = 2.4V			-400	µA
	Input high current DCLK				40	µA
I <sub>CC</sub>	V <sub>CC</sub> supply current	V <sub>IN</sub> = 0V, V <sub>CC</sub> = Max Figure 5			80	mA
	V <sub>BB</sub> supply current				120	mA

## Color/Monochrome Attributes Controller (CMAC)

SCB2675

AC ELECTRICAL CHARACTERISTICS  $T_A = 0^\circ\text{C}$  to  $+70^\circ\text{C}$ ,  $V_{CC} = +5V \pm 5\%$ ,  $V_{BB} = \text{Figure 5}^4, 5$ 

SYMBOL	PARAMETER	TEST CONDITIONS	LIMITS				UNIT
			25MHz Version		18MHz Version		
			Min	Max	Min	Max	
<b>Dot clock timing (see Figure 8)</b>							
$f_D$	Frequency			25			MHz
$t_{DH}$	High time		15		22	18	ns
$t_{DL}$	Low time		15		22		ns
<b>Setup times (see Figures 6, 7, 9, and 10)</b>							
$t_{SB}$	BLANK to $\overline{\text{CCLK}}$		40		50		ns
$t_{SA}$	Attributes to $\overline{\text{CCLK}}$		40		50		ns
$t_{SD}$	D0 - D9 to $\overline{\text{CCLK}}$		70		70		ns
$t_{SK}$	CURSOR to $\overline{\text{CCLK}}$		40		50		ns
$t_{SC}$	C0, C1 to DCLK		30		35		ns
$t_{SR}$	RBLANK to DCLK		20		20		ns
$t_{SM}$	BLINK, UL, DOTS to BLANK		20		20		ns
<b>Hold times (see Figures 6, 7, 9, and 10)</b>							
$t_{HB}$	BLANK from $\overline{\text{CCLK}}$		20		20		ns
$t_{HA}$	Attributes from $\overline{\text{CCLK}}$		20		20		ns
$t_{HD}$	D0 - D8 from $\overline{\text{CCLK}}$		30		30		ns
$t_{HK}$	CURSOR from $\overline{\text{CCLK}}$		20		20		ns
$t_{HC}$	C0, C1 from DCLK		20		20		ns
$t_{HR}$	RBLANK from DCLK		20		20		ns
$t_{HM}$	BLINK, UL, DOTS from BLANK		20		20		ns
<b>Delay times (see Figure 8)</b>							
$t_{DC}$	$\overline{\text{CCLK}}$ from DCLK			55		70	ns
$t_{DV}$	Other outputs from DCLK	$C_L = 50\text{pF}$		60		70	ns

## NOTES:

- Stresses above those listed under Absolute Maximum Ratings may cause permanent damage to the device. This is a stress rating only and functional operation of the device at these or at any conditions other than those described in the AC and DC Electrical Characteristics section of this specification is not implied.
- For operating at elevated temperatures, the device must be derated based on  $+150^\circ\text{C}$  maximum junction temperature.
- This product includes circuitry specifically designed for the protection of its internal devices from damaging effects of excessive static charge. Nonetheless, it is suggested that conventional precautions be taken to avoid applying voltages greater than the rated maxima.
- Parameters are valid over operating temperature range unless otherwise specified.
- All voltage measurements are referenced to ground. For testing, all input signals swing between 0.4V and 2.4V with a transition time of 3ns maximum and output voltages are checked at 0.8V and 2V.

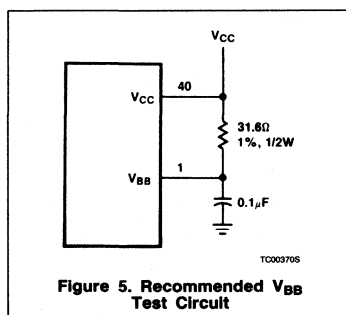

**Figure 5. Recommended  $V_{BB}$  Test Circuit**

Color/Monochrome Attributes Controller (CMAC)

SCB2675

2

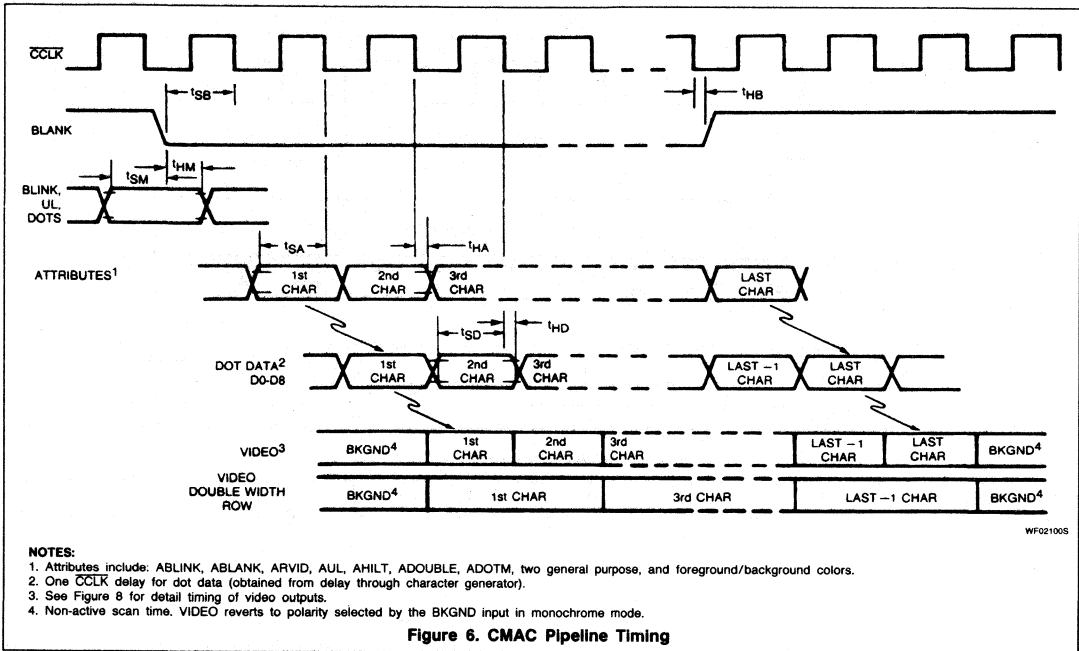

Figure 6. CMAC Pipeline Timing

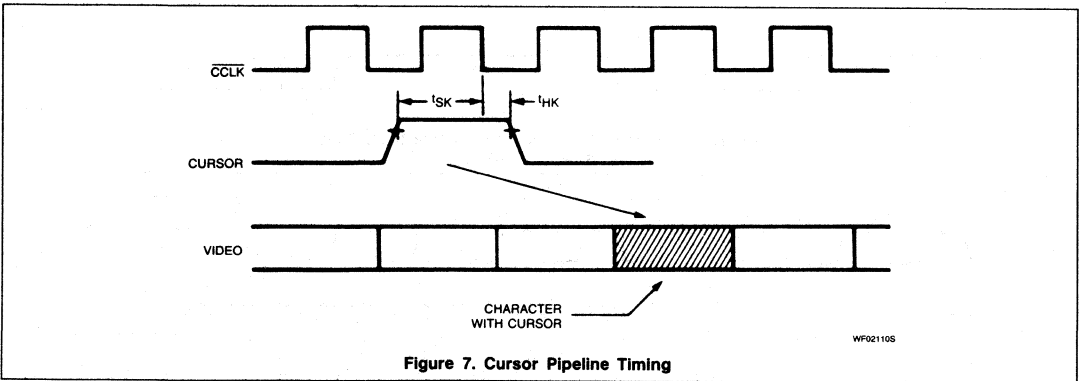

Figure 7. Cursor Pipeline Timing

Color/Monochrome Attributes Controller (CMAC)

SCB2675

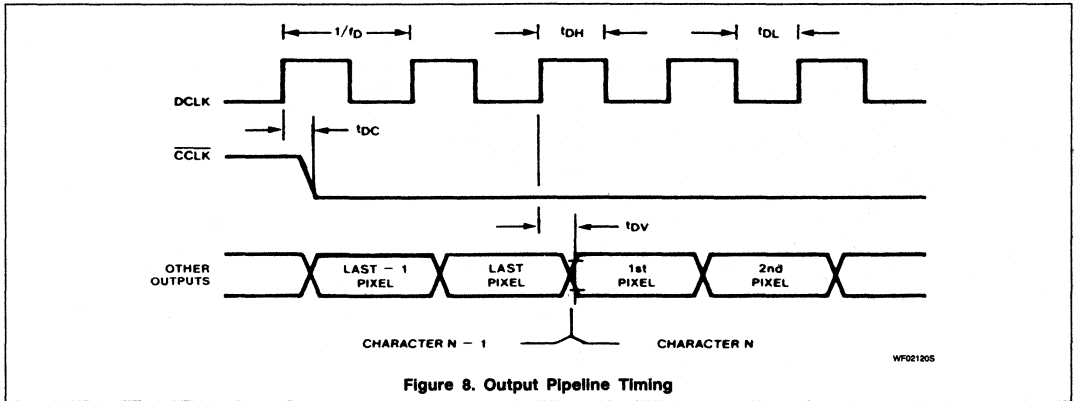

Figure 8. Output Pipeline Timing

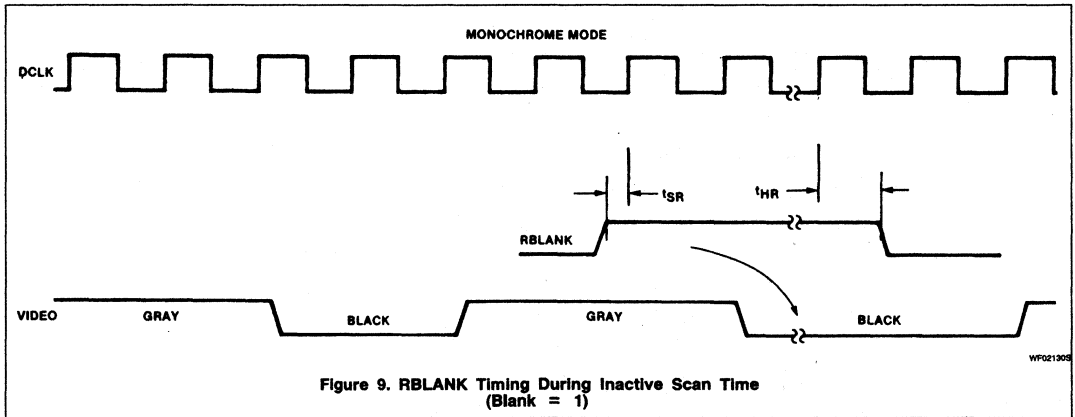

Figure 9. RBLANK Timing During Inactive Scan Time (Blank = 1)

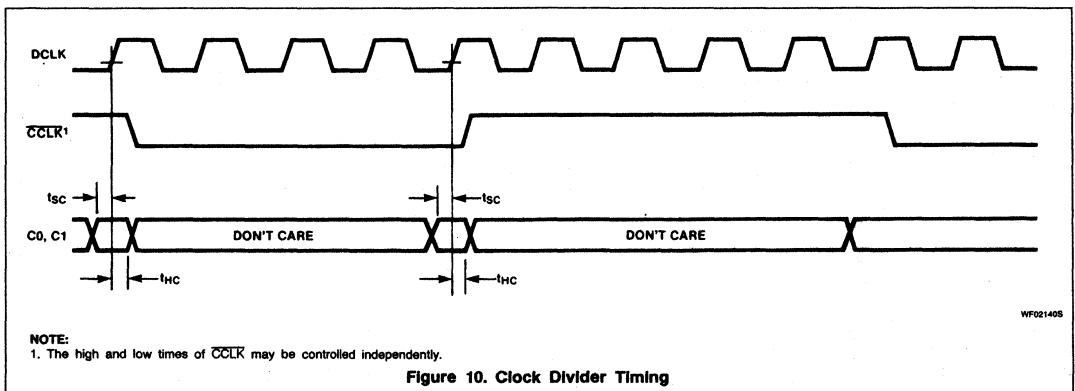

Figure 10. Clock Divider Timing

# Color/Monochrome Attributes Controller (CMAC)

# SCB2675

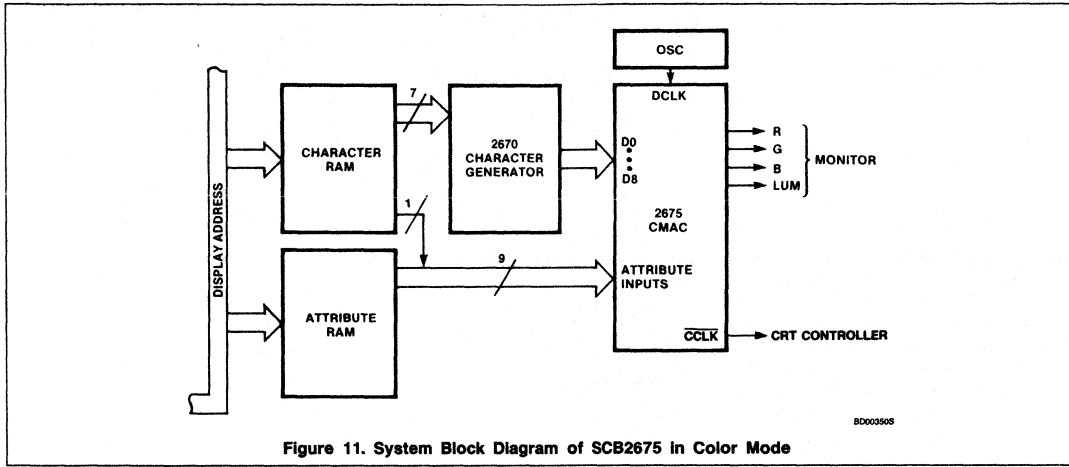

Figure 11. System Block Diagram of SCB2675 in Color Mode

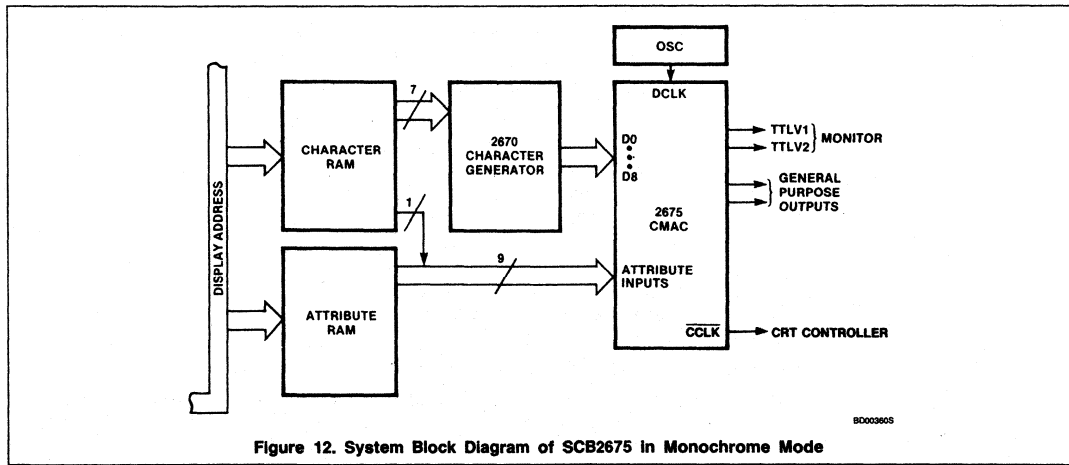

Figure 12. System Block Diagram of SCB2675 in Monochrome Mode

# SCB2675T

## Turbo Color/Monochrome Attributes Controller (Turbo-CMAC)

Preliminary Specification

### Microprocessor Products

#### DESCRIPTION

The Signetics SCB2675T Turbo Color/Monochrome Attributes Controller (Turbo-CMAC) is a bipolar LSI device designed for CRT terminals and display systems that employ raster scan techniques. It contains a programmable dot clock divider to generate a character clock, a high-speed shift register to serialize input dot data into a video stream, latches and logic to apply visual attributes to the resulting display, and logic to display a cursor on the display.

The Turbo-CMAC provides control of visual attributes on a character by character basis for two operating modes: monochrome and color. The monochrome mode provides reverse video, blank, highlight and two general purpose user definable attributes. In this mode, the display characters can be specified to appear on either a light or dark screen background. Retrace video suppression can be automatically or externally controlled. The color mode provides eight colors for foreground (character) video and eight colors for background video together with a luminance output for external color set selection or to simultaneously drive a monochrome monitor. Additionally, both modes provide double width, underline, blink, dot stretching and dot width attributes. In monochrome mode, the SCB2675T emulates the attribute characteristics of Digital Equipment Corporation's VT100 terminal.

The horizontal dot frequency is the basic timing input to the Turbo-CMAC. This clock is divided internally to provide a character clock output for system synchronization. Up to nine bits of dot data are parallel loaded into the video shift register on each character boundary. The two TTL video data outputs in monochrome mode are encoded to provide four video intensities (black, gray, white and highlight). The video data in color mode is encoded to provide eight foreground colors and shifted out on three TTL outputs, together with the luminance output.

#### FEATURES

- 40MHz video dot rate version
- Four video intensities encoded on two TTL outputs (monochrome mode)
- Eight foreground and background colors encoded on three TTL outputs (color mode)
- Internally latched character attributes:
  - Reverse video
  - Blank
  - Blink
  - Underline
  - Highlight
  - Two general purpose
  - Eight foreground colors
  - Eight background colors
  - Dot width control
  - Double width characters
- VT100 compatible attributes
- Reverse video cursor with optional white cursor in color mode
- Up to 10 dots per character
- Light or dark background in monochrome mode
  - Automatic retrace blanking
- Programmable dot stretching
- Compatible with SCN2674 AVDC and SCN2670 DCGG
- TTL compatible
- 40-pin dual in-line package

#### APPLICATIONS

- CRT terminals
- Word processing systems
- Small business computers

#### PIN CONFIGURATION

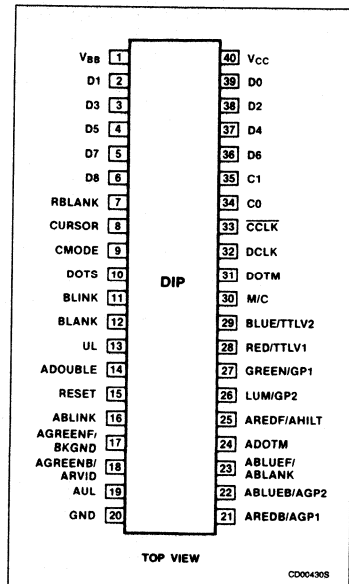



# Turbo Color/Monochrome Attributes Controller (Turbo-CMAC) SCB2675T

## ORDERING INFORMATION

PACKAGES	DOTS PER CHARACTER	$V_{CC} = 5V \pm 5\%$ , $0^{\circ}C$ to $+70^{\circ}C$
		40MHz
Plastic DIP	7, 8, 9, 10	SCB2675TC4N40

**2**

## BLOCK DIAGRAM

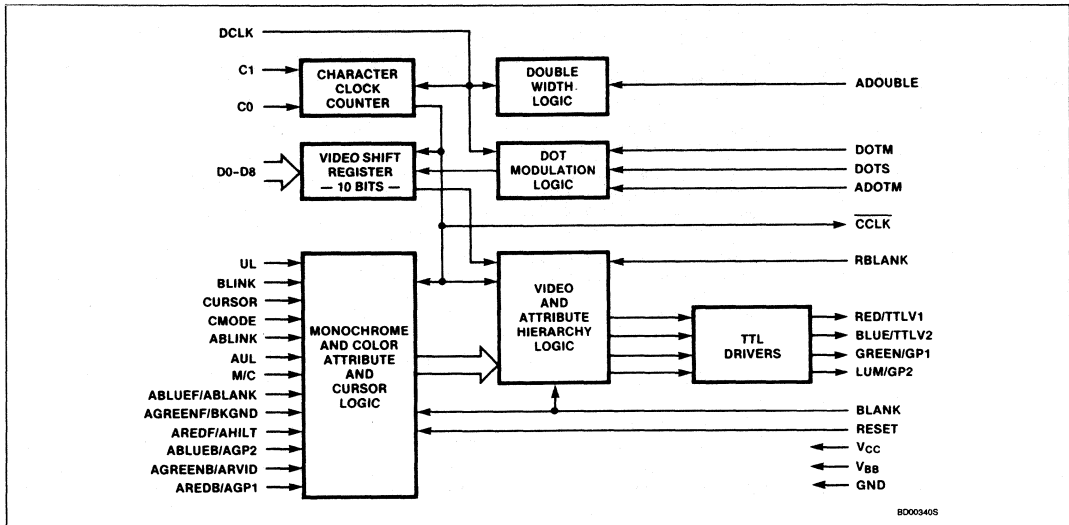

# Turbo Color/Monochrome Attributes Controller (Turbo-CMAC) SCB2675T

## PIN DESCRIPTION

MNEMONIC	PIN NO.	TYPE	NAME AND FUNCTION
	DIP		
V <sub>CC</sub>	40	I	<b>Power Supply:</b> +5V <sub>DC</sub>
V <sub>BB</sub>	1	I	<b>Bias Supply:</b> See Figure 5
GND	20	I	<b>Ground:</b> 0V reference
DCLK	32	I	<b>Dot Clock:</b> Dot frequency input. Video output shift rate.
CCLK	33	O	<b>Character Clock:</b> An output which is a submultiple of DCLK. The period ranges from 7 to 10 DCLK periods per cycle and is determined by the state of the C0-C1 inputs.
RED/TTLV1	28	O	<b>Red/TTL Video 1:</b> In color mode, this output provides the red gun serial video. In monochrome mode, it should be used with the blue/TTL video 2 output to decode four video intensities.
BLUE/TTLV2	29	O	<b>Blue/TTL Video 2:</b> In color mode, this output provides the blue gun serial video. In monochrome mode, it should be used with the red/TTL video 1 output to decode four video intensities.
GREEN/GP1	27	O	<b>Green/General Purpose 1:</b> In color mode, this output provides the green gun serial video. In monochrome mode, it is a general purpose TTL output which is asserted if the AREDB/AGP1 input is asserted when the corresponding character dot data is loaded into the video shift register. GP1 can be active in either active scan or blank time.
LUM/GP2	26	O	<b>Luminance/General Purpose 2:</b> In color mode, this output is the logical-OR of the RGB foreground video. It is low during a blanking interval and during the foreground portion of the cursor display. In monochrome mode, it is a general purpose TTL output which is asserted if the ABLUEB/AGP2 input is asserted when the corresponding character dot data is loaded into the video shift register. GP2 can be active in either active scan or blank time.
UL	13	I	<b>Underline Timing:</b> Indicates the scan line(s) for the underline attribute. Latched on the falling edge of BLANK. The underline will be displayed on the specified scan line for every character where AUL = 1.
BLINK	11	I	<b>Blink Timing:</b> This input is sampled on the falling edge of BLANK to provide the blink rate for the blink attribute. Should be a submultiple of the frame rate.
BLANK	12	I	<b>Screen Blank:</b> When high, this input forces the video outputs to the specified background color in color mode and to the level specified by the BKGND input (either black or gray) in monochrome mode.
RBLANK	7	I	<b>Retrace Blank:</b> This input is used to force the video outputs to a low during retrace periods. If pulled high, it will automatically suppress video during the retrace periods when BLANK is high. The user may also pulse this input while BLANK is high to selectively suppress raster video.
AGREENF/ BKGND	17	I	<b>Green Foreground/Background Intensity:</b> In color mode, this input activates the GREEN/GP1 output during the foreground (character video) portion of the associated character block. In monochrome mode, this input specifies gray or black screen background.
ABLUEF/ ABLANK	23	I	<b>Blue Foreground/Blank Attribute:</b> In color mode, this input activates the BLUE/TTLV2 output during the foreground (character video) portion of the associated character block. In monochrome mode, this input generates a blank space for the associated character. The blank space intensity is controlled by the AGREENF/BKGND input, the reverse video attribute and cursor input.
AREDF/AHILT	25	I	<b>Red Foreground/Highlight Attribute:</b> In color mode, this input activates the RED/TTLV1 output during the foreground (character video) portion of the associated character block. In monochrome mode, this input highlights the associated character (including underline).
CURSOR	8	I	<b>Cursor Timing:</b> This input provides the timing for the cursor video. In color mode, with CURSOR and CMODE high, the RGB outputs are driven high (white cursor). If CMODE is low, or in monochrome mode, this input reverses the intensities of the video and attributes (the foreground and background intensities are reversed). Cursor position, shape, and blink rate are controlled by this input.
CMODE	9	I	<b>Cursor Mode:</b> Used in color mode only. When CURSOR and CMODE are high, the RGB outputs are driven high (white cursor). When CURSOR is high and CMODE is low, the RGB outputs are logically inverted (reverse video cursor).
AUL	19	I	<b>Underline Attribute:</b> Specifies a line to be displayed in the character block. The specific line(s) are specified by the UL input. All other attributes apply to the underline video.

# Turbo Color/Monochrome Attributes Controller (Turbo-CMAC) SCB2675T

2

## PIN DESCRIPTION (Continued)

MNEMONIC	PIN NO.	TYPE	NAME AND FUNCTION
	DIP		
ABLANK	16	I	<b>Blink Attribute:</b> In color mode, this active high input will drive the foreground RGB combination to the background RGB combination. In monochrome mode, the associated character or background is driven to the intensity determined by BKGND, reverse video attribute and the cursor input.
ADDOUBLE	14	I	<b>Double Width Attribute:</b> This active high input causes the associated character video to be shifted out of the serial shift register at one half the dot frequency (DCLK). The CCLK output is not affected.
AREDB/AGP1	21	I	<b>Red Background/General Purpose Attribute 1:</b> In color mode, this input activates the RED/TTLV1 output during the background portion of the associated character block. In monochrome mode, it activates the GREEN/GP1 output for the associated character block.
ABLUEB/AGP2	22	I	<b>Blue Background/General Purpose Attribute 2:</b> In color mode, this input activates the BLUE/TTLV2 output during the background portion of the associated character block. In monochrome mode, it activates the LUM/GP2 output for the associated character block.
AGREENB/ ARVID	18	I	<b>Green Background/Reverse Video Attribute:</b> In color mode, this input activates the GREEN/GP1 output during the background portion of the associated character block. In monochrome mode, it causes the associated character block video intensities to be reversed.
DO - DB	39, 2, 38, 3, 37, 4, 36, 5, 6	I	<b>Dot Data Input:</b> These are parallel inputs corresponding to the character/graphic symbol dot data for a given scan line. These inputs are strobed into the video shift register on the trailing (falling) edge of each character clock (CCLK).
C0, C1	34, 35	I	<b>Character Clock Control:</b> The states of these two static inputs determine the internal divide factor for the CCLK output rate.
RESET	15	I	<b>Reset:</b> This active high input initializes the internal logic and resets the attribute latches.
M/C	30	I	<b>Monochrome/Color Mode:</b> This input selects whether the CMAC operates in monochrome or color mode. A low selects color mode and a high selects monochrome mode.
ADOTM	24	I	<b>Dot Modulation Attribute:</b> When DOTM and this input are high, the active dot width of the associated character video is one DCLK. When DOTM is high and this input is low, the active dot width of the associated character video is two DCLKs.
DOTM	31	I	<b>Dot Width Modulation:</b> When this input is high, two DCLKs are used for each dot shifted through the shift register. When this input is low, one DCLK is used.
DOTS	10	I	<b>Dot Stretching:</b> Sampled at the falling edge of BLANK. When this input is high, one extra dot is appended to individual dots or groups of dots of the input parallel data and then transferred through the shift register. When this input is low, normal transfer of input parallel data results.

## FUNCTIONAL DESCRIPTION

The Turbo-CMAC consists of seven major sections (see block diagram). The high speed dot clock input is applied to a programmable divider to provide a character clock output for system timing. Parallel dot data is loaded into the video shift register on character boundaries and shifted into the video logic block at the dot rate specified by the dot modulation section. The appropriate attribute control inputs are selected by the mode select logic, latched internally on character boundaries, and combined with the serial dot data to provide monochrome or color video outputs.

The BLANK input defines the active screen and retrace areas. In color mode, the video outputs are forced to the specified background color when this signal is asserted; in monochrome mode the video outputs are forced to the states defined by the BKGND input; i.e., black if dark background is selected and gray if light background is selected. A separate RBLANK input allows the user to select the amount of border around the active area when operating in color mode or in

monochrome mode with light background. This input can be tied high, in which case the area outside the active area will be dark, or it may be pulsed during BLANK periods to externally control the border widths.

In color mode, eight colors for the character (foreground) and eight colors for the background (area other than character) can be selected by the attribute inputs. In monochrome mode, the intensities of foreground and background are a function of the attribute and BKGND inputs; i.e., characters may be black, gray, white, or highlight (very white) while background may be black, gray, or white (see Table 1).

### Character Clock Counter

The character clock counter divides the DCLK input to generate the character clock (CCLK). The divide factor is specified by the clock control inputs (C1 - C0) as follows:

C1	C0	SCB2675T	
		Dots/ Char.	CCLK Duty Cycle*
0	0	10	5/5
0	1	7	3/4
1	0	8	4/4
1	1	9	4/5

**NOTE:**  
\*High/Low

The number of dot clocks/character is normally the number of dots/character as listed above. However, when dot width control is specified, the DCLK input is divided by two before it is applied to the character clock counter resulting in the number of dot clocks/character being double those listed above, although the number of displayed dots/character remains the same. (See Dot Modulation Logic section). The number of dots per character (C1 - C0) can be dynamically changed on either edge of the character clock as shown in Figure 10.

# Turbo Color/Monochrome Attributes Controller (Turbo-CMAC) SCB2675T

**Table 1. Monochrome Mode Attribute Characteristics**

REV <sup>1</sup>	AHILT	ABLANK <sup>2</sup>	FOREGROUND VIDEO	BACKGROUND VIDEO
0	0	0	W	B
0	0	1	W/G	B
0	1	0	H	B
0	1	1	H/W	B
1	0	0	B	G
1	0	1	B/W	G/B
1	1	0	B	W
1	1	1	B/H	W/B

**NOTES:**

- REV = (BKGND) XOR (ARVID):
 

BKGND	ARVID	REV
0	0	0
0	1	1
1	0	1
1	1	0
- For blinking, the video outputs are shown as 0/1, where 0 and 1 are the blink timing output states.
- Foreground includes underline when underlining is specified by AUL = 1.
- When ABLANK = 1, foreground component becomes same as background component.
- Codes for video outputs are as follows:

CODE	TTLV2	TTLV1	BEAM INTENSITY
B	0	0	Black (B)
G	0	1	Gray (G)
W	1	0	White (W)
H	1	1	Highlight (H)

### Video Shift Register

On each character boundary, the parallel input dot data (D0 – D8) is loaded into the video shift register. The data is shifted out least significant bit first (D0) at the DCLK rate. If 10 dots/character are specified (C1 – C0 = 00), the tenth dot will be the same as D8. The serial dot data from the video shift register is routed to the video logic where it is combined with the cursor and attribute control bits to produce the video data outputs.

### Mode Select, Attribute and Cursor Control

The mode select logic multiplexes the monochrome and color attribute inputs and outputs as specified by the M/C input. The monochrome mode provides blank, reverse video, highlight and two general purpose attributes. The latter may be used, with external logic, to combine other attributes (e.g., overscore) into the video stream. The color mode provides RGB foreground and background color attributes. Both modes provide double width characters, blink, underline, dot width control and dot stretching.

The cursor and attribute inputs are pipelined internally to allow for system pipeline propagations. The cursor input and the attribute inputs are delayed for one  $\overline{CLK}$  to account for the delay of the character data through the character generator latches. The attribute timing inputs (BLINK, UL and DOTS) are clocked into the 2675 at the beginning of each scan line time by the falling edge of BLANK. Thus, these inputs must be in their proper state at the falling edge of BLANK

preceding the scan line where they are required to be active. The BLANK signal itself is also delayed internally to provide for the RAM and character generator delays (see Figures 6 and 7). Internal delays cause the video outputs to be delayed relative to  $\overline{CLK}$  as illustrated in Figure 8.

### Video Logic

Each character block consists of the three components shown in Figure 1. Symbol video is generated from the dot data inputs D0 – D8. Underline video is enabled by the AUL attribute and is generated during the scan lines for which the UL input is active. Underline and symbol video are always the same intensity or color, and other attributes (e.g., ABLINK) apply to them equally. The combination of underline and symbol video is also referred to as foreground video. Background video is the area of the character block corresponding to the absence of foreground video. The assertion of the non-display attribute (ABLANK) in the monochrome mode causes the entire character block to be displayed as background.

In monochrome mode, the serial dot data and pipelined cursor and attributes are combined to generate four video intensities (black, gray, white and highlight) which are encoded on the TTLV1 and TTLV2 outputs as follows:

TTLV2	TTLV1	VIDEO INTENSITY
0	0	Black
0	1	Gray
1	0	White
1	1	Highlight

Table 1 describes the relationship between attributes and video intensity of the foreground and background components of the character block in monochrome mode.

In color mode, the colors of the foreground and background components are specified by the corresponding attribute inputs; AREDF, AGREENF and ABLUEF dictate the color of the foreground component while AREDB, AGREENB and ABLUEB do the same for the background component. In this mode, the serial dot data and pipelined cursor and attributes are combined to generate four video outputs. The RED, GREEN and BLUE outputs separately contain the corresponding foreground and background components. The LUM output is the logical-OR of the foreground colors and can be used to drive a separate monochrome monitor or to select a different set of colors for the foreground.

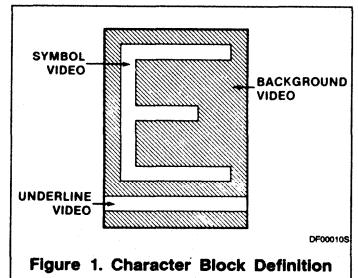

**Figure 1. Character Block Definition**

### Dot Modulation Logic

The dot modulation logic controls the video shift register to supply dot stretching and dot width control.

Dot stretching is controlled by the DOTS input which is sampled each scan line at the trailing (falling) edge of BLANK. If DOTS is asserted at that time, all characters on the following scan line will have dot stretching applied. Dot stretching causes an extra dot to be added to individual dots or groups of dots as shown in Figures 2 and 3. Dot stretching can be used to:

- Compensate for low video bandwidth monitors (since the minimum active displayed segment with dot stretching is two DCLKs).
- Assure crisp black characters when operating in white background mode.
- Provide thick characters as a means of distinguishing areas of the display.

# Turbo Color/Monochrome Attributes Controller (Turbo-CMAC) SCB2675T

Dot width is controlled by the DOTM and ADOTM inputs. DOTM is tied either high, which enables the feature on the entire display, or low, which disables the feature. With ADOTM high, the dot width of characters can be selectively controlled by assertion of the ADOTM attribute input. When operating in this mode, the dot clock input is divided by two before being applied to other circuits in the Turbo-CMAC.

The  $\overline{CCLK}$  output is also divided by two. The truth table for the possible combinations of ADOTM and DOTM is as follows:

ADOTM	DOTM	OPERATION
0	0	Normal mode
0	1	Dot width control, 100% duty cycle (DCLK÷2, $\overline{CCLK} \div 2$ )
1	0	Not allowed
1	1	Dot width control, 50% duty cycle (DCLK÷2, $\overline{CCLK} \div 2$ )

When dot width control is enabled as above, two DCLKs are used for each video dot period. Asserting ADOTM for a particular character will cause each active video dot of the displayed character to be turned on for one DCLK and off for the other DCLK, while if ADOTM is negated for that character, the active video dot for that character will be turned on (black background) or off (white background) for both DCLK times (see figures 2 and 4). Only the character video component of the character block is modulated. Underline video and background are not affected by on-time modulation. Width control can be used to:

1. Make horizontal lines and vertical lines appear the same brightness on the display.
2. Provide two different brightness levels for characters without requiring a monitor with analog brightness inputs.

However, note that the effects produced by this feature are highly dependent on the video amplifier characteristics of the monitor used.

### Double Width Logic

The double width logic controls the rate at which dots are shifted through the video shift register. When the ADOUBLE input is asserted, the associated character video will be shifted at one half the DCLK rate, and the dot information for the next character will be loaded into the shift register two  $\overline{CCLK}$ s later. The character and attribute data that is present on the first  $\overline{CCLK}$  after the ADOUBLE input is asserted will be ignored. The  $\overline{CCLK}$  output is not affected. If a double width character is specified at the last location of a character row, the second half of the double width character (one  $\overline{CCLK}$ ) will extend into the horizontal front porch.

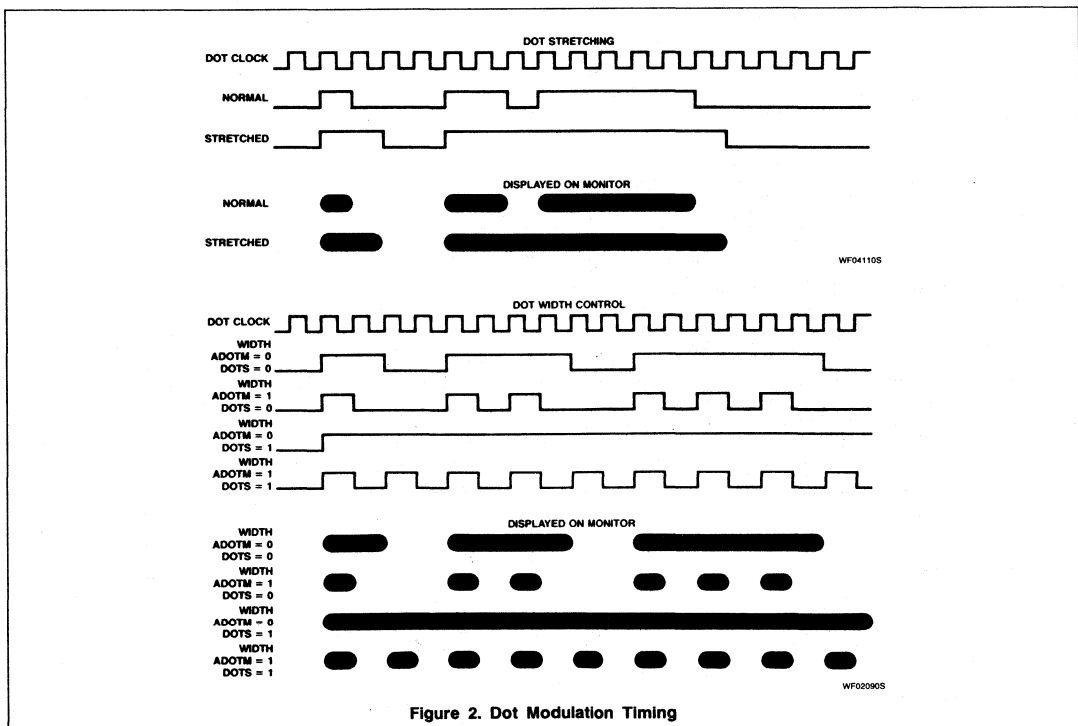

Figure 2. Dot Modulation Timing

# Turbo Color/Monochrome Attributes Controller (Turbo-CMAC) SCB2675T

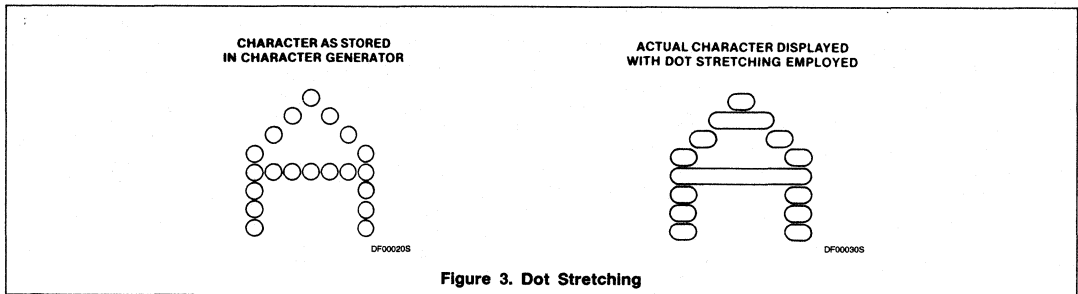

Figure 3. Dot Stretching

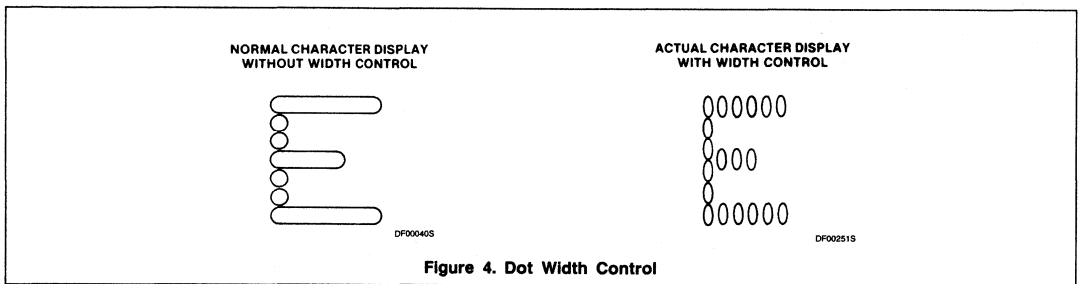

Figure 4. Dot Width Control

## ABSOLUTE MAXIMUM RATINGS<sup>1</sup>

SYMBOL	PARAMETER	RATING	UNIT
T <sub>A</sub>	Operating ambient temperature <sup>2</sup> range	0 to +70	°C
T <sub>SRG</sub>	Storage temperature range	-65 to +150	°C
	All voltages with respect to ground <sup>3</sup>	-0.5 to +6.0	V

## DC ELECTRICAL CHARACTERISTICS T<sub>A</sub> = 0°C to +70°C, V<sub>CC</sub> = 5V ± 5%, V<sub>BB</sub> = Figure 5<sup>4, 5</sup>

SYMBOL	PARAMETER	TEST CONDITIONS	LIMITS		UNIT
			Min	Max	
V <sub>IL</sub>	Input low voltage	I <sub>OL</sub> = 4mA I <sub>OH</sub> = -400µA V <sub>IN</sub> = 0.4V	2	0.8	V
V <sub>IH</sub>	Input high voltage			0.4	V
V <sub>OL</sub>	Output low voltage			2.4	V
V <sub>OH</sub>	Output high voltage			2.4	V
I <sub>IL</sub>	Input low current DCLK All other inputs	V <sub>IN</sub> = 0.4V		-800 -400	µA µA
I <sub>IH</sub>	Input high current DCLK All other inputs	V <sub>IN</sub> = 2.4V		40 20	µA µA
I <sub>CC</sub>	V <sub>CC</sub> supply current	V <sub>IN</sub> = 0V, V <sub>CC</sub> = Max Figure 5		30	mA
I <sub>BB</sub>	V <sub>BB</sub> supply current			110	mA

# Turbo Color/Monochrome Attributes Controller (Turbo-CMAC) SCB2675T

**2**

## AC ELECTRICAL CHARACTERISTICS $T_A = 0^\circ\text{C}$ to $+70^\circ\text{C}$ , $V_{CC} = 5V \pm 5\%$ , $V_{BB} = \text{Figure 5}^4, 5$

SYMBOL	PARAMETER	TEST CONDITIONS	TENTATIVE LIMITS		UNIT
			40MHz Version		
			Min	Max	
<b>Dot clock timing (Figure 8)</b>					
$f_D$	Frequency			40	MHz
$t_{DH}$	High time		10		ns
$t_{DL}$	Low time		10		ns
<b>Setup times (Figures 6, 7, 9 and 10)</b>					
$t_{SB}$	BLANK to $\overline{CCLK}$		35		ns
$t_{SA}$	Attributes to $\overline{CCLK}$		40		ns
$t_{SD}$	D0-D9 to $\overline{CCLK}$		50		ns
$t_{SK}$	CURSOR to $\overline{CCLK}$		35		ns
$t_{SC}$	C0, C1 to DCLK		15		ns
$t_{SR}$	RBLANK to DCLK		15		ns
$t_{SM}$	BLINK, UL, DOTS to BLANK		10		ns
<b>Hold times (Figures 6, 7, 9 and 10)</b>					
$t_{HB}$	BLANK from $\overline{CCLK}$		5		ns
$t_{HA}$	Attributes from $\overline{CCLK}$		5		ns
$t_{HD}$	D0-D8 from $\overline{CCLK}$		5		ns
$t_{HK}$	CURSOR from $\overline{CCLK}$		5		ns
$t_{HC}$	C0, C1 from DCLK		5		ns
$t_{HR}$	RBLANK from DCLK		10		ns
$t_{HM}$	BLINK, UL, DOTS from BLANK		15		ns
<b>Delay times (Figure 8)</b>					
$t_{DC}$	$\overline{CCLK}$ from DCLK	$C_L = 50\text{pF}$		45	ns
$t_{DV}$	Other outputs from DCLK			45	ns

**NOTES:**

- Stresses above those listed under Absolute Maximum Ratings may cause permanent damage to the device. This is a stress rating only and functional operation of the device at these or at any conditions other than those described in the AC and DC Electrical Characteristics section of this specification is not implied.
- For operating at elevated temperatures, the device must be derated based on  $+150^\circ\text{C}$  maximum junction temperature.
- This product includes circuitry specifically designed for the protection of its internal devices from damaging effects of excessive static charge. Nonetheless, it is suggested that conventional precautions be taken to avoid applying voltages greater than the rated maxima.
- Parameters are valid over operating temperature range unless otherwise specified.
- All voltage measurements are referenced to ground. For testing, all input signals swing between 0.4V and 2.4V with a transition time of 3ns maximum. All time measurements are referenced at input voltages of 0.8V and 2V and output voltages are checked at 0.8V and 2V.

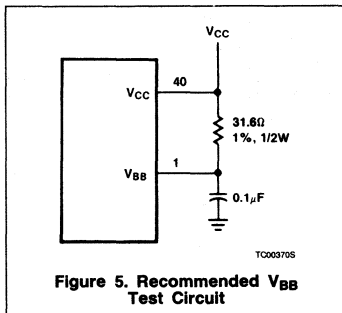

**Figure 5. Recommended  $V_{BB}$  Test Circuit**

# Turbo Color/Monochrome Attributes Controller (Turbo-CMAC) SCB2675T

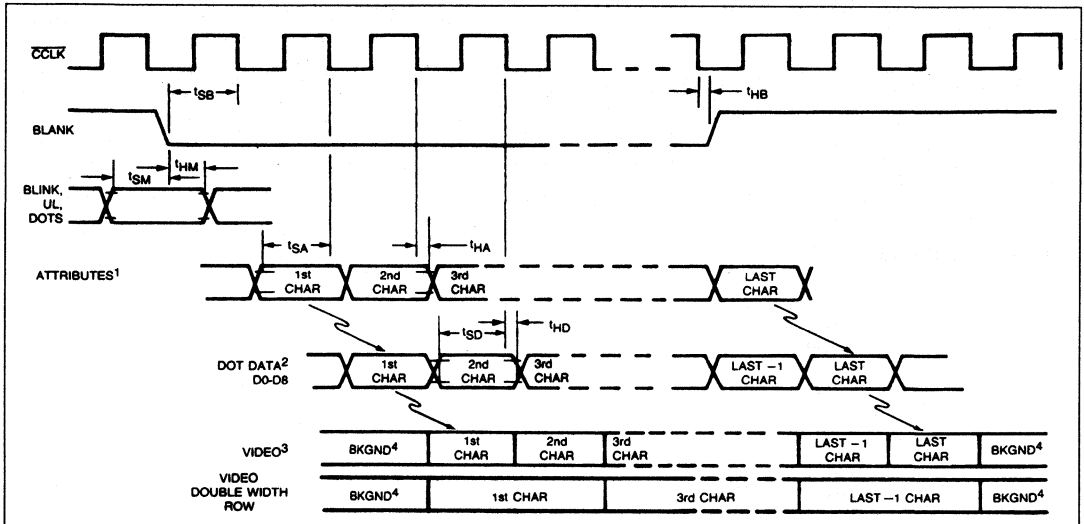

WF021005

**NOTES:**

1. Attributes include ABLINK, ABLANK, ARVID, AUL, AHILT, ADOUBLE, ADOTM, two general purpose, and foreground/background colors.
2. One CCLK delay for dot data (obtained from delay through character generator).
3. See Figure 8 for detail timing of video outputs.
4. Non-active scan time. VIDEO reverts to polarity selected by the BKGND input in monochrome mode.

**Figure 6. Turbo-CMAC Pipeline Timing**

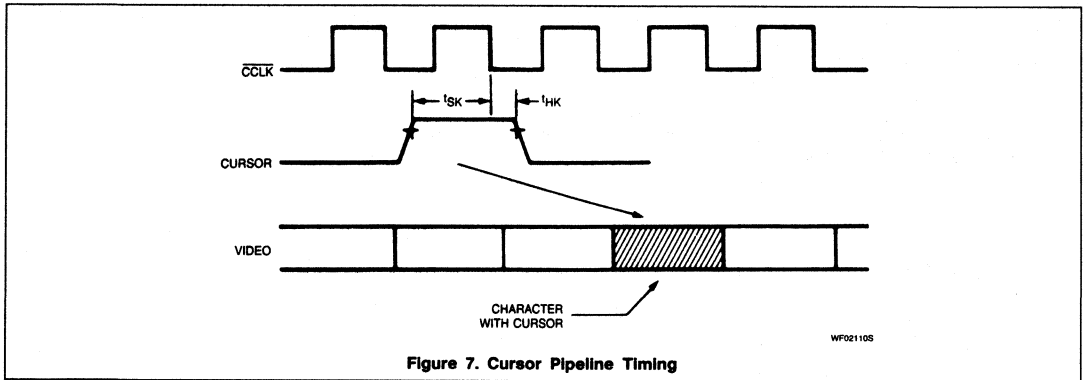

WF021105

**Figure 7. Cursor Pipeline Timing**



# Turbo Color/Monochrome Attributes Controller (Turbo-CMAC) SCB2675T

2

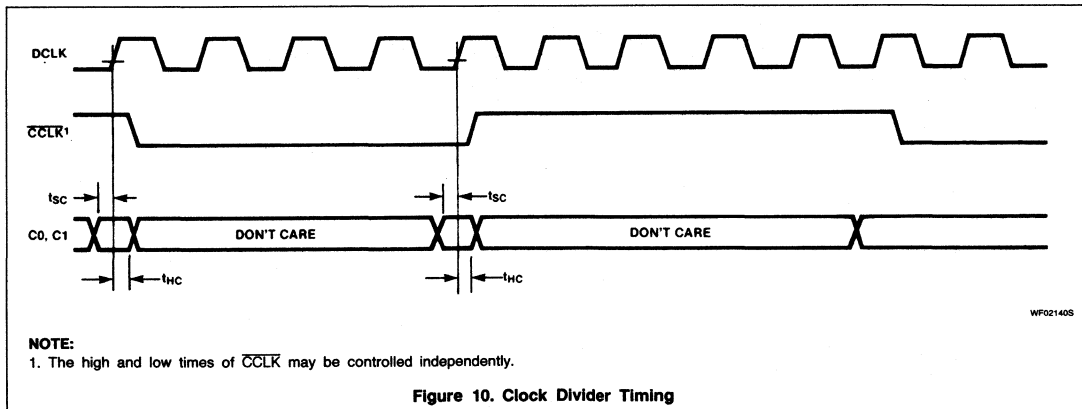
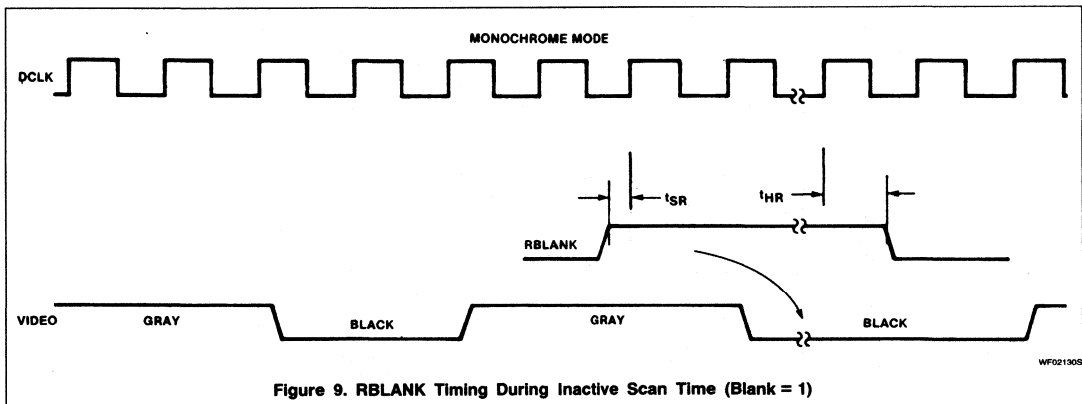
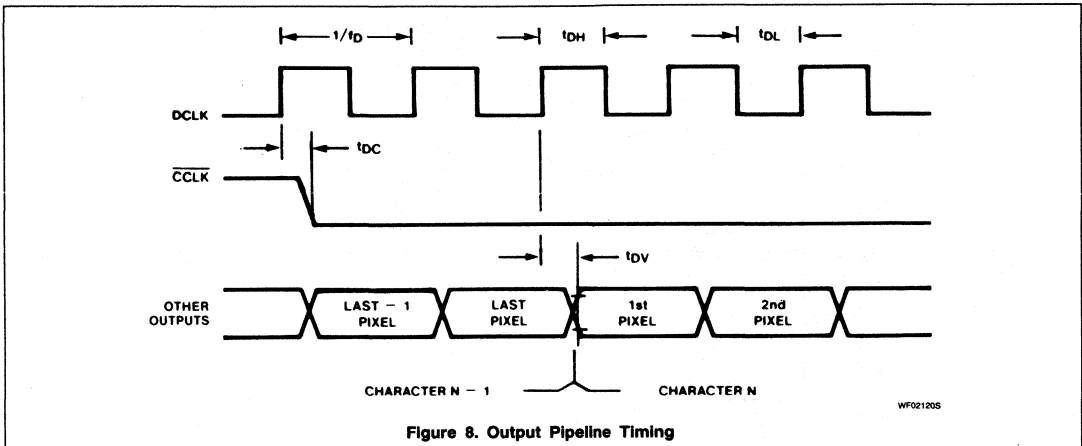

Turbo Color/Monochrome Attributes Controller (Turbo-CMAC) SCB2675T

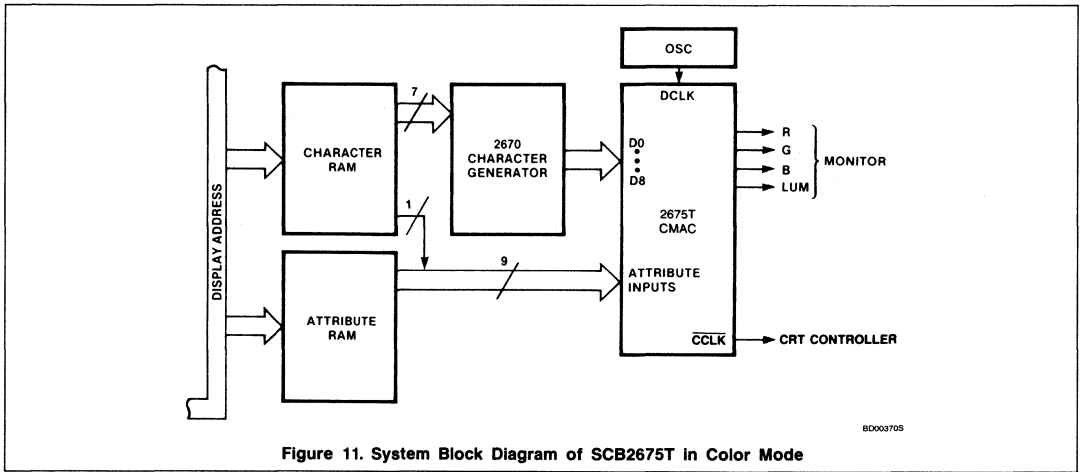

Figure 11. System Block Diagram of SCB2675T in Color Mode

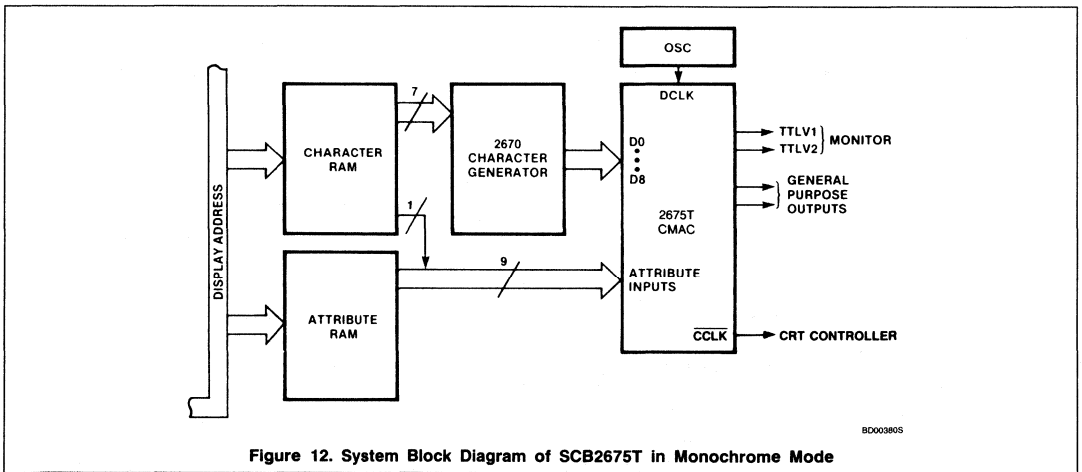

Figure 12. System Block Diagram of SCB2675T in Monochrome Mode

# SCB2677

## Video Attributes Controller (VAC)

Product Specification

### Microprocessor Products

#### DESCRIPTION

The Signetics SCB2677A and SCB-2677B Video Attributes Controllers (VAC) are bipolar LSI devices designed for CRT terminals and display systems that employ raster scan techniques. Each contains a high-speed video shift register, field and character attributes logic, attribute latch, cursor format logic and half-dot shift control.

The VAC provides control of visual attributes on a field or character-by-character. Internal logic preserves field attribute data from character row to character row so that an attribute byte is not required at the beginning of each row. The SCB2677B provides for reverse video, blank (non-display), blink, underline and highlight attributes and a graphics mode attribute to work in conjunction with the Signetics SCN2670 Display Character and Graphics Generators (DCGG). The SCB2677A substitutes a strike-through attribute for the graphics attribute.

The horizontal dot frequency is the basic timing input to the VAC. Internally, this clock is divided down to provide a character clock output for system synchronization. Up to ten bits of video dot data are parallel-loaded into the video shift register on each character boundary. The video data is encoded to three levels of intensity (black, gray and white) and output on two TTL outputs. Light or dark screen background may be specified.

#### FEATURES

- 18MHz and 25MHz video dot rates
- Three level-encoded TTL video outputs
- Character/field attribute logic
  - Reverse video
  - Character blank
  - Character blink
  - Underline
  - Highlight
- Strike-through or graphics control
- Field attributes extend from row to row
- Light or dark field
- Cursor reverse video logic
- Up to 12 dots per character
- Retrace blanking for light field
- Optional field graphics control output
- High-speed bipolar design
- TTL compatible
- Compatible with Signetics SCN2672 PVTC, SCN2674 AVDC and SCN2670 DCGG
- Upgrade of the Signetics SCB2673 VAC

#### APPLICATIONS

- CRT terminals
- Word processing systems
- Small business computers

#### PIN CONFIGURATIONS

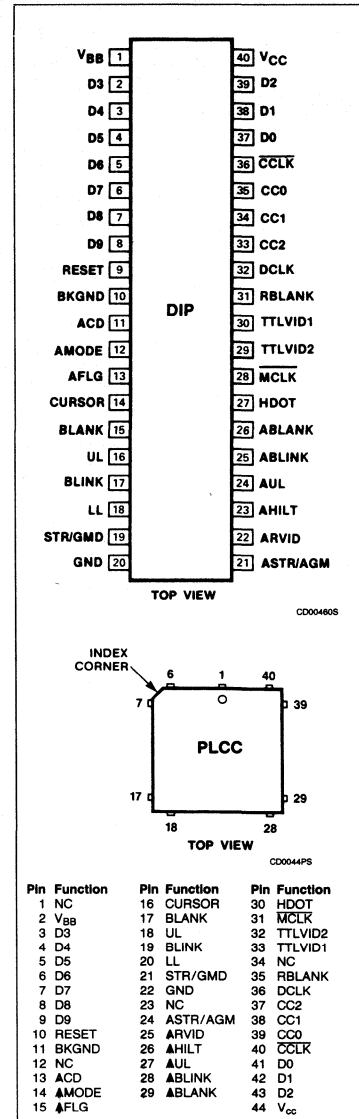

# Video Attributes Controller (VAC)

# SCB2677

## ORDERING INFORMATION

PACKAGES	$V_{CC} = +5V \pm 5\%$ , $T_A = 0^\circ C$ to $+70^\circ C$			
	Graphics Attribute		Strike-Through Attribute	
	25MHz	18MHz	25MHz	18MHz
Ceramic DIP	SCB2677BC5I40	SCB2677BC8I40	SCB2677AC5I40	SCB2677AC8I40
Plastic DIP	SCB2677BC5N40	SCB2677BC8N40	SCB2677AC5N40	SCB2677AC8N40
Plastic LCC	SCB2677BC5A44	SCB2677BC8A44	SCB2677AC5A44	SCB2677AC8A44

## BLOCK DIAGRAM

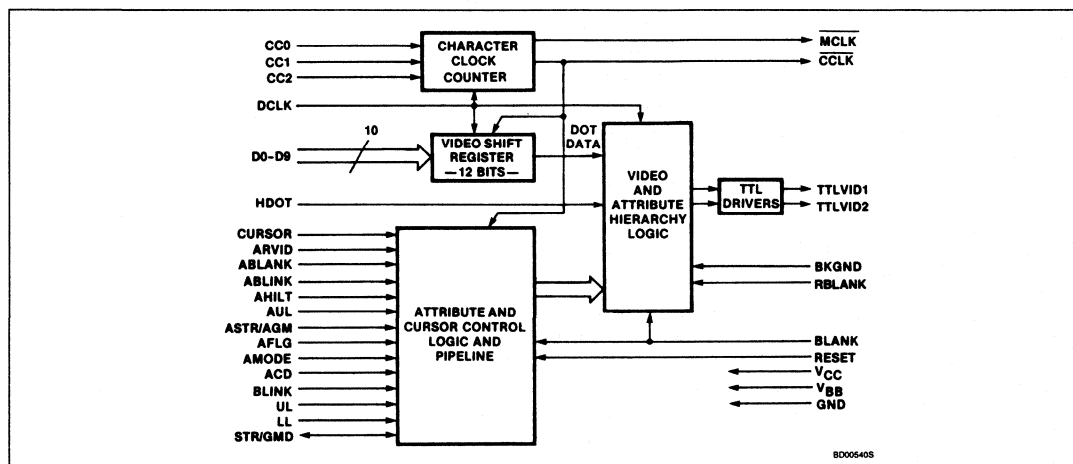

## Video Attributes Controller (VAC)

SCB2677

## PIN DESCRIPTION

MNEMONIC	PIN NO.		TYPE	NAME AND FUNCTION
	DIP	PLCC		
DCLK	32	36	I	<b>Dot Clock:</b> Dot frequency input. Video output shift rate.
ĀCLK	36	40	O	<b>Character Clock:</b> A submultiple of DCLK. The frequency ranges from one sixth to one twelfth of DCLK, as determined by the state of the CC0-CC2 inputs.
CC2 - CC0	33 - 35	37 - 39	I	<b>Character Clock Control:</b> The logic state on these three static inputs determine the internal divide factor for the ĀCLK output rate. Character clock rates of 6 through 12 dots per character may be specified.
D0 - D9	37 - 39, 2 - 8	41 - 43, 3 - 9	I	<b>Dot Data Input:</b> These are parallel inputs corresponding to the character/graphic symbol dot data for a given scan line. These inputs are strobed into the video shift register on the falling edge of each character clock.
HDOT	27	30	I	<b>Half-Dot Shift:</b> When this input is high, the serial video output is delayed by one-half dot time. This input is latched on the falling edge of each character clock.
CURSOR	14	16	I	<b>Cursor Timing:</b> This input provides the timing for the cursor video. When high, effectively reverses the intensities of the video and attributes. Cursor position, shape, and blink rate are controlled by this input.
BKGND	10	11	I	<b>Background Intensity:</b> Specifies light or dark video during BLANK and character fields. Affects the intensities of all attributes.
BLANK	15	17	I	<b>Screen Blank:</b> When high, this input forces the video outputs to the level specified by the BKGND input (either high or low intensity). Not effective when RBLANK is high.
RBLANK	31	35	I	<b>Retrace Blank:</b> This input is used to force the two video outputs to a low intensity (black) during retrace intervals. If held high (1), it will automatically suppress video when BLANK is high (1). The user may pulse this input while BLANK is high to selectively suppress raster video.
ARVID	22	25	I	<b>Reverse Video Attribute:</b> The intensity of the associated character or field video is reversed. All other attributes are effectively reversed.
AHILT	23	26	I	<b>Highlight Attribute:</b> All-dot video (including underline) of the associated character or field is highlighted with respect to the BKGND input and the reverse video attribute.
ABLANK	26	29	I	<b>Blank Attribute:</b> Generates a blank space in the associated character or field. The blank space intensity is determined by the BKGND input, the reverse video attribute, and the CURSOR input.
ABLINK	25	28	I	<b>Blink Attribute:</b> The associated character or field video is driven to the intensity determined by BKGND and the reverse video attribute when the BLINK input is high.
AUL	24	27	I	<b>Underline Attribute:</b> Specifies a line to be displayed on the character or field. The line is specified by the UL input. All other attributes apply to the underline video.
ASTR/AGM	21	24	I	<b>Strike-Through Attribute (2677A):</b> Specifies a line to be displayed on the character or field. The line is specified by the STR input.  <b>Attribute Graphics Mode (2677B):</b> This input is latched and synchronized to provide a field GMD output for the SCN2670 DCGG.
AMODE	12	14	I	<b>Attribute Mode:</b> Specifies character (AMODE = 0) or field (AMODE = 1) attribute mode.
AFLG	13	15	I	<b>Attributes Flag:</b> The VAC samples and latches the attributes inputs when this input is high. If field attributes are specified (AMODE = 1), the attributes are double buffered on a row basis. Thus, each scan line of every character row will start with the attributes that were valid at the end of the previous row.
ACD	11	13	I	<b>Attribute Control Display:</b> In field attributes mode (AMODE = 1), if ACD = 0, the first character in each new attribute field (the attribute control character) will be suppressed and only the attributes will be displayed. If ACD = 1, the first character and the attributes are displayed. This input has no effect in character mode (AMODE = 0).
BLINK	17	19	I	<b>Blink:</b> This input is sampled on the falling edge of the BLANK to provide the blink rate for the character blink attribute. It should be a submultiple of the frame rate.
UL	16	18	I	<b>Underline:</b> Indicates the scan line(s) for the underline attribute. Latched on the falling edge of BLANK.

## Video Attributes Controller (VAC)

SCB2677

## PIN DESCRIPTION (Continued)

MNEMONIC	PIN NO.		TYPE	NAME AND FUNCTION
	DIP	PLCC		
STR/GMD	19	21	I  O	<b>Strike-Through Line (2677A):</b> Indicates the scan line(s) for the strike-through attribute. Latched on the falling edge of BLANK. <b>Graphics Mode (2677B):</b> This output provides a synchronized, latched, field graphics mode corresponding to the AGM input. This output can be used to control the GM input on the SCN2670 DCGG.
LL	18	20	I	<b>Last Line:</b> Indicates the last scan line of each character row. Used internally to extend field attributes across row boundaries. Latched on the falling edge of BLANK. This input has no effect in character mode (AMODE = 0).
MCLK	28	31	O	<b>Memory Clock:</b> This output is active for the last dot time for each CCLK period. See Figure 1.
TTLVID1	30	33	O	<b>TTL Video 1:</b> This output corresponds to the serial, non-highlighted video dot pattern.
TTLVID2	29	32	O	<b>TTL Video 2:</b> This output corresponds to the highlighted serial video dot pattern. Should be used with TTLVID1 to decode a composite video of three intensities.
RESET	9	10	I	<b>Manual Reset:</b> This active high input initializes the internal logic and resets the attribute latches.
VCC	40	44	I	<b>Power Supply:</b> +5V.
VBB	1	2	I	<b>Bias Supply:</b> See Figure 14.
GND	20	22	I	<b>Ground:</b> 0V reference.

## FUNCTIONAL DESCRIPTION

The VAC consists of four major sections (see block diagram). The high-speed dot clock input is divided internally to provide a character clock for system timing. The parallel dot data is loaded into the video shift register on each character boundary and shifted into the video logic block at the dot rate. The six attribute inputs are latched internally and combined with the serial dot data to provide a three level video source for the monitor.

A separate BLANK input defines the active screen area. When BLANK = 0, the video levels are derived internally by the combinations of dot data, attributes, cursor, and the state of the BKGND input. Either black, gray or white background can be selected. Symbols (dot data) are normally gray and can be highlighted to white or black as shown in Figure 2.

During the inactive screen area (BLANK = 1), the video level produced by the TTL outputs is either gray (BKGND = 1) or black (BKGND = 0). A separate retrace blank (RBLANK) input is provided to suppress raster retrace video when gray background is specified. This input will force the video outputs to a low if RBLANK and BLANK = 1. The user may pulse RBLANK during the retrace interval in order to extend the gray border closer to the monitor edges.

## Character Clock Counter

The character clock counter divides the frequency on the DCLK input to generate the character clock (CCLK). The divide factor is specified by the clock control inputs

CC2	CC1	CC0	CCLK	
			Dots/Character	Duty Cycle*
0	0	0	6	3/3
0	0	1	6	3/3
0	1	0	7	4/3
0	1	1	8	4/4
1	0	0	9	5/4
1	0	1	10	5/5
1	1	0	11	6/5
1	1	1	12	6/6

## NOTE:

\*Low/high

(CC0 - CC2) as shown in the table above. See Figure 1.

## Video Shift Register

On each character boundary, the parallel data (D0 - D9) is loaded into the video shift register. The data is shifted out least significant bit first (D0) by the DCLK. If 11 or 12 dots/character are specified (CC2 - CC0 = 110 or 111), a 0 (blank dot) is always shifted out before D0. For 12 dots/character, a 0 is also shifted out after D9. The serial dot data is shifted into the video logic where it is combined with the cursor and attributes to encode three levels of video.

## Attribute And Cursor Control

The VAC visual attributes capabilities include: reverse video, character blank, blink, underline, highlight, and strike-through. The six attributes and the three attribute control inputs (AMODE, AFLG, and ACD) are clocked into the VAC on the falling edge of CCLK. If AFLG is high, the attributes are latched inter-

nally and are effective for either one character time (AMODE = 0) or until another set of attributes is latched (AMODE = 1). The attributes set is double-buffered on a row-by-row basis internally. Using this technique, field attributes can extend across character row boundaries thereby eliminating the necessity of starting each row with an attribute set.

When field attribute mode is selected, (AMODE = 1), the VAC will accommodate two attribute storage configurations. In one configuration, the attribute control data is stored in the refresh RAM, taking the place of the first character code in the field to be affected. For this mode, the ACD input is tied low and blank characters will be displayed in the screen positions occupied by the attribute data (see Figure 12). The display RAM contains intermixed character and attribute data. When new attribute data is written to the SCB2677, the AFLG input is set high. The character at that location will be blanked, and

# Video Attributes Controller (VAC)

SCB2677

2

only the attribute information will be displayed. That particular attribute data will be used for the resultant characters until the next AFLG pulse occurs. In the second configuration (ACD = 1), the character codes and attribute data are presented to the VAC in parallel (i.e., there are separate RAMs for the character and attribute data). In this mode, dot data is displayed at each character position (see Figure 13).

The CURSOR and the attribute input signals are pipelined internally to allow for system propagations (one CCLK for refresh RAM, one CCLK for dot generator). The attribute timing signals BLINK, UL, STR and LL are clocked into the VAC at the beginning of each scan line by the falling edge of the BLANK preceding the scan line at which they are to be active (see Figure 5). The SCN2670 DCGG delays the character dot data by one character clock. The VAC assumes that there is a DCGG in the system and latches the dot data one character clock later than the latching of the attribute data.

### Video Logic

The serial dot data and the pipelined cursor and attributes are combined to generate three levels (white, gray, and black) on two TTL compatible outputs, TTLVID1 and TTLVID2. The three levels are encoded as shown to the right.

The video is normally shifted out on the leading edge of the DCLK. When the HDOT input is asserted, the corresponding dot data is delayed by one-half DCLK. This half dot shifting, when used on selected lines of

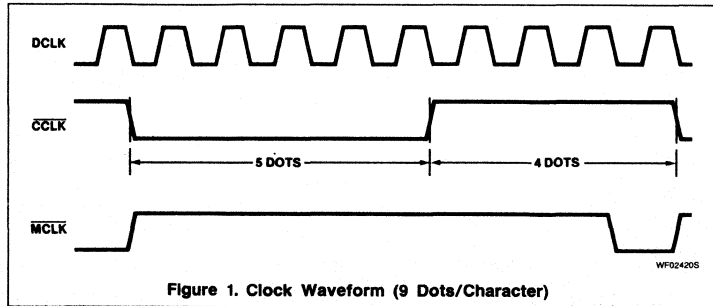

Figure 1. Clock Waveform (9 Dots/Character)

TTLVID2	TTLVID1	INTENSITY
0	0	Black
0	1	Gray
1	0	Not used
1	1	White

**NOTE:**

The TTLVID1 output can be used independently to generate a two-level non-highlighted video.

character video, can be used to effect eye-pleasing character rounding as shown in Figure 3. The half-dot shift does not extend into the next character's field boundary.

### Attribute Hierarchy

The video of each character block consists of four components as shown in Figure 4.

Symbol video is generated from the dot data inputs D0 - D9.

Underline video is enabled by the AUL attribute and is generated when the UL timing input is active. Underline and symbol video are always the same intensity.

Strike-through video is enabled by the ASTR attribute and is generated when the STR timing input is active. This video is the same intensity as the symbol and underline video. This feature applies to the SCB2677A only.

Surround video is the absence of symbol, underline and strike-through video or the presence of the non-display attributes (ABLANK or ABLINK • BLINK).

The relative intensities of the four video components are determined by the remaining attributes (AHILT, ABLANK, ABLINK, ARVID) and the BKGND and CURSOR inputs as illustrated in Table 1.

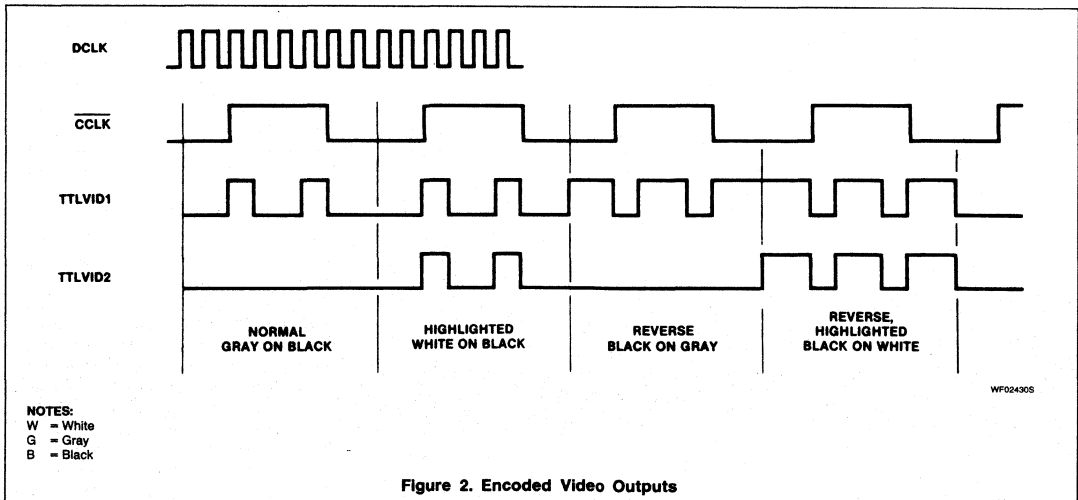

Figure 2. Encoded Video Outputs

# Video Attributes Controller (VAC)

SCB2677

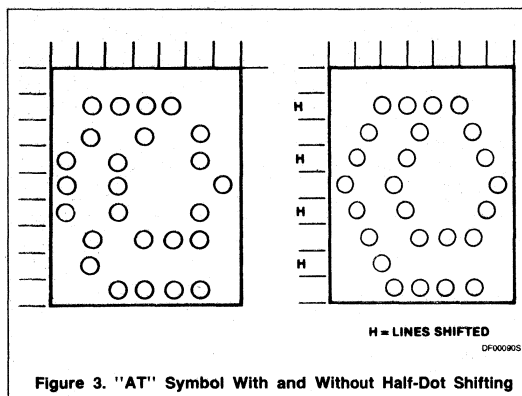

Figure 3. "AT" Symbol With and Without Half-Dot Shifting

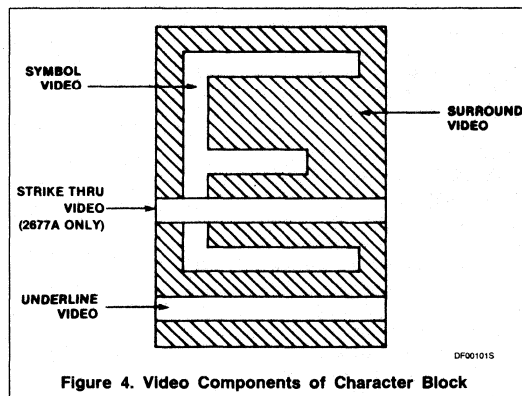

Figure 4. Video Components of Character Block

Table 1. Attributes Hierarchy

BLANK	RBLANK	BKGND	REVERSE <sup>1</sup>	AHILT	"NON-" DISPLAY <sup>2</sup>	SYMBOL, UNDERLINE OR STRIKE- THROUGH <sup>3, 4</sup>	SURROUND VIDEO <sup>3</sup>
0	d	0	0	0	0	G	B
0	d	0	0	0	1	B	B
0	d	0	0	1	0	W	B
0	d	0	0	1	1	B	B
0	d	0	1	0	0	B	G
0	d	0	1	0	1	G	G
0	d	0	1	1	0	B	W
0	d	0	1	1	1	W	W
0	d	1	0	0	0	B	G
0	d	1	0	0	1	G	G
0	d	1	0	1	0	B	W
0	d	1	0	1	1	W	W
0	d	1	1	0	0	G	B
0	d	1	1	0	1	B	B
0	d	1	1	1	0	W	B
0	d	1	1	1	1	B	B
1	0	0	d	d	d	B	B
1	0	1	d	d	d	G	G
1	1	d	d	d	d	B	B

**NOTES:**

B = Black  
G = Gray  
W = White

d = Don't care

1. REVERSE = ARVID ⊗ CURSOR

2. Non-display = (ABLANK • BLINK) + ABLANK

3. See Figure 4.

4. Symbol, underline and strike-through are always same intensity.



## Video Attributes Controller (VAC)

SCB2677

ABSOLUTE MAXIMUM RATINGS<sup>1</sup>

SYMBOL	PARAMETER	RATING	UNIT
T <sub>A</sub>	Operating ambient temperature <sup>2</sup> range	0 to +70	°C
T <sub>STG</sub>	Storage temperature range	-65 to +150	°C
	All voltages with respect to ground	-0.5 to +6.0	V

DC ELECTRICAL CHARACTERISTICS T<sub>A</sub> = 0°C to +70°C, V<sub>CC</sub> = +5V ± 5%, V<sub>BB</sub> = See Figure 14<sup>3, 4, 5, 6</sup>

SYMBOL	PARAMETER	TEST CONDITIONS	LIMITS			UNIT
			Min	Typ	Max	
V <sub>IL</sub>	Input low voltage				0.8	V
V <sub>IH</sub>	Input high voltage		2			V
V <sub>OL</sub>	Output low voltage	I <sub>OL</sub> = 4mA			0.4	V
V <sub>OH</sub>	Output high voltage	I <sub>OH</sub> = -400μA	2.4			V
I <sub>IL</sub>	Input low current	V <sub>IN</sub> = 0.4V			-400/ -800 <sup>6</sup>	μA
I <sub>IH</sub>	Input high current	V <sub>IN</sub> = 2.4V			20/40 <sup>6</sup>	μA
I <sub>CC</sub>	V <sub>CC</sub> supply current	V <sub>IN</sub> = 0V, V <sub>CC</sub> = Max			80	mA
I <sub>BB</sub>	V <sub>BB</sub> supply current	V <sub>BB</sub> = Max			120	mA

## NOTES:

- Stresses above those listed under Absolute Maximum Ratings may cause permanent damage to the device. This is a stress rating only and functional operation of the device at these or at any other condition above those indicated in the operation section of this specification is not implied.
- Operating at elevated temperatures, the device must be derated based on +150°C maximum junction temperature.
- Parameters are valid over operating temperature range unless otherwise specified.
- All voltage measurements are referenced to ground (V<sub>SS</sub>). All input signals swing between 0.4V and 2.4V. All time measurements are referenced at input voltages of 0.8V, 2V and at output voltage of 0.8V, 2V as appropriate.
- Typical values are at +25°C, typical supply voltages and typical processing parameters.
- For DCLK input.
- C<sub>L</sub> less than 150pF minimum could be faster.

## Video Attributes Controller (VAC)

SCB2677

**AC ELECTRICAL CHARACTERISTICS**  $T_A = 0^\circ\text{C}$  to  $+70^\circ\text{C}$ ,  $V_{CC} = +5V \pm 5\%$ ,  $V_{BB} =$  See Figure 14<sup>3, 4, 5, 6</sup>

SYMBOL	PARAMETER	TEST CONDITIONS	LIMITS				UNIT
			25MHz Version		18MHz Version		
			Min	Max	Min	Max	
<b>Dot clock (Figure 11)</b>							
$f_D$	Frequency			25			MHz
$t_{DH}$	High		15		22		ns
$t_{DL}$	Low		15		22		ns
<b>Setup times to <math>\overline{CCLK}</math> (Figures 5, 6, 7 and 11)</b>							
$t_{BS}$	BLANK		50		50		ns
$t_{SC}$	BLINK, UL, STR, LL (ref to BLANK)		20		20		ns
$t_{SA}$	Attributes		45		55		ns
$t_{SD}$	Dot data D0 – D9		70		70		ns
$t_{SK}$	CURSOR		50		50		ns
$t_{FS}$	AFLG		50		65		ns
$t_{SH}$	HDOT		45		55		ns
<b>Hold times from <math>\overline{CCLK}</math> (Figures 5, 6, 7 and 11)</b>							
$t_{HC}$	BLINK, UL, STR, LL (ref to BLANK)		20		20		ns
$t_{HA}$	Attributes		20		20		ns
$t_{HD}$	Dot data D0 – D9		30		30		ns
$t_{HK}$	CURSOR		20		20		ns
$t_{FH}$	AFLG		30		30		ns
$t_{HH}$	HDOT		20		20		ns
<b>Setup times to DCLK (Figures 9,10)</b>							
$t_{SG}$	BKGND		15		15		ns
$t_{SB}$	RBLANK		15		15		ns
$t_{CS}$	CC0 – CC2		30		35		ns
<b>Hold times from DCLK (Figures 9,10)</b>							
$t_{HG}$	BKGND		15		15		ns
$t_{HB}$	RBLANK		15		15		ns
$t_{CH}$	CC0 – CC2		20		20		ns
<b>Delay times (Figures 7 and 8)</b>							
$t_{DGM}$	GMD from DCLK	$C_L = 150\text{pF}$		65		65	ns
$t_{DC}$	MCLK, $\overline{CCLK}$ from DCLK			65		65	ns
$t_{DV}^7$	TTLVID1 and TTLVID2 from DCLK			75		80	ns

Video Attributes Controller (VAC)

SCB2677

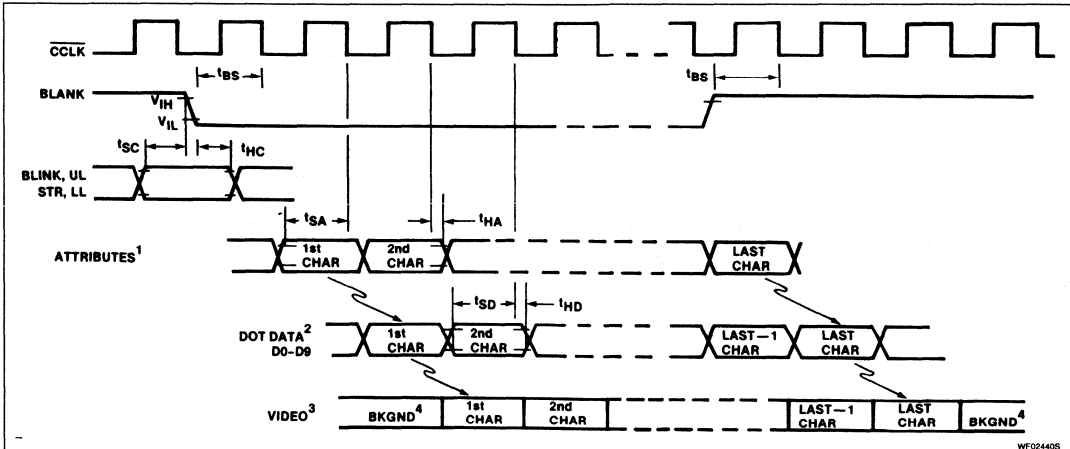

WF024405

- NOTES:
1. Attributes include: ABLINK, ABLANK, ARVID, AUL, AHILT, and ASTR.
  2. One CCLK delay for dot data (obtained from delay through character generator).
  3. See Figure 8 for detail timing of TTLVID1, TTLVID2.
  4. Non-active scan time. VIDEO reverts to polarity selected by the BKGND input.

Figure 5. VAC Pipeline Timing

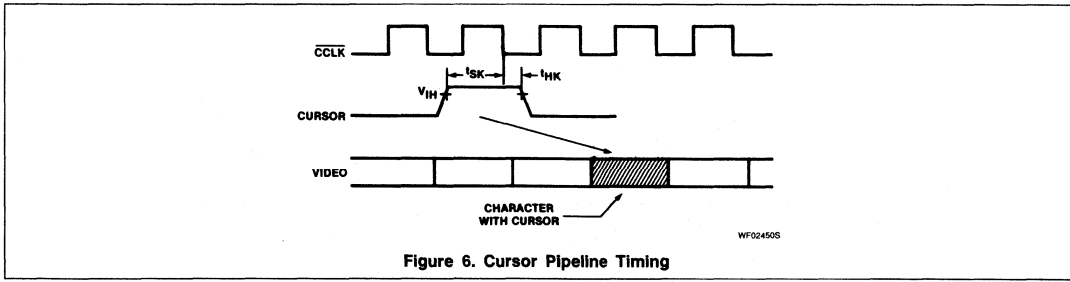

WF024505

Figure 6. Cursor Pipeline Timing

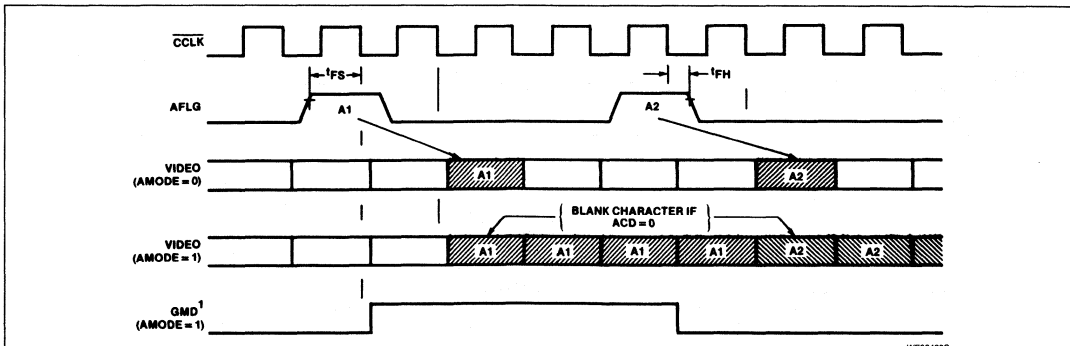

WF024605

- NOTE:
1. GMD output in SCB2677B version only. See Figure 8 for detail timing.

Figure 7. Character (AMODE = 0), Field (AMODE = 1), and GMD Attribute Timing

Video Attributes Controller (VAC)

SCB2677

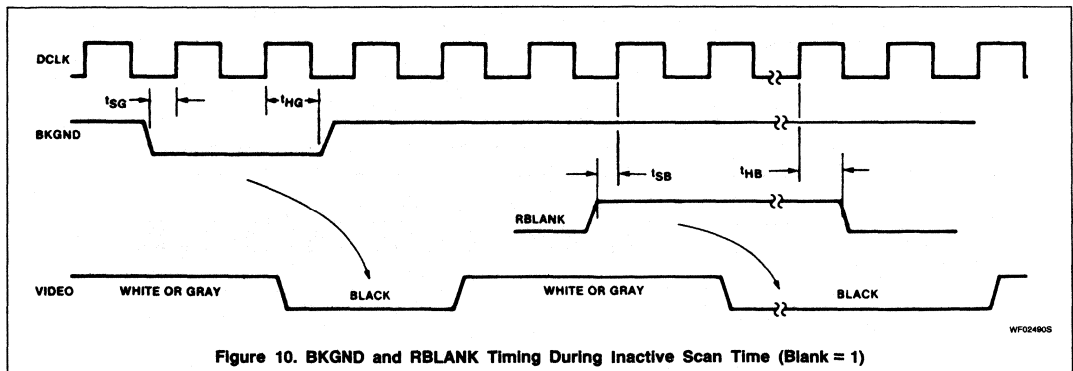
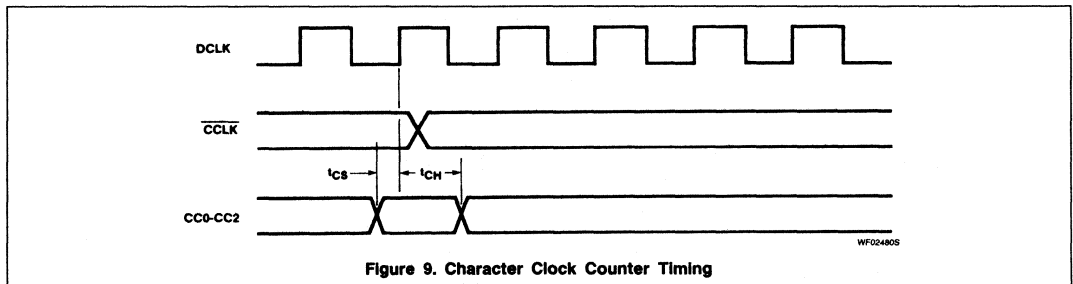
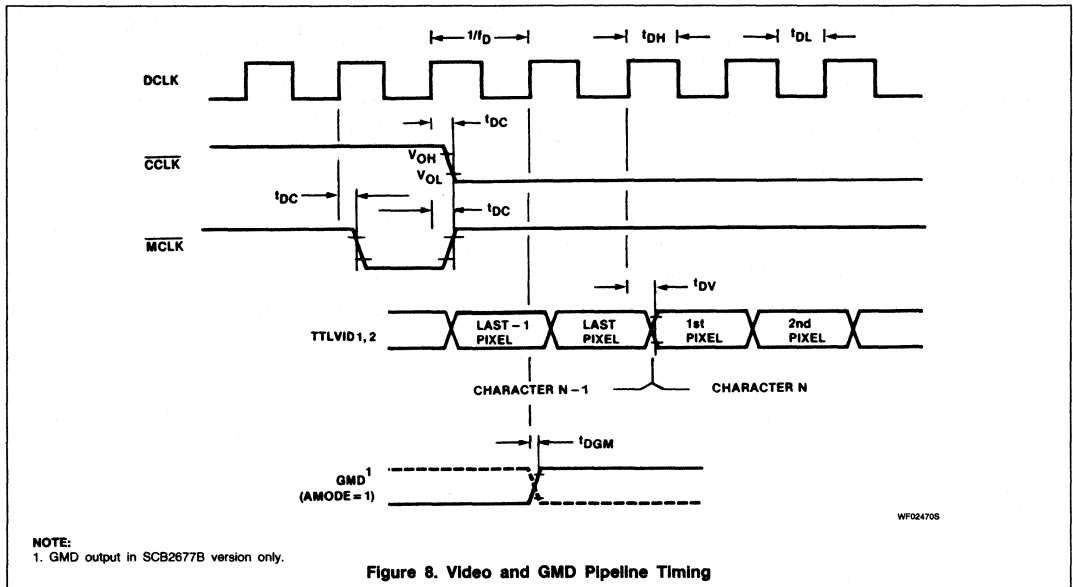

Video Attributes Controller (VAC)

SCB2677

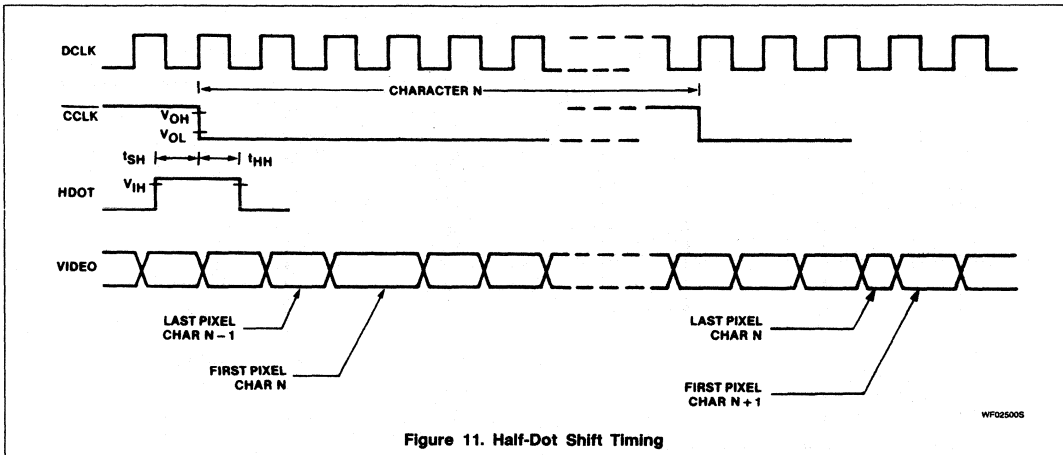

Figure 11. Half-Dot Shift Timing

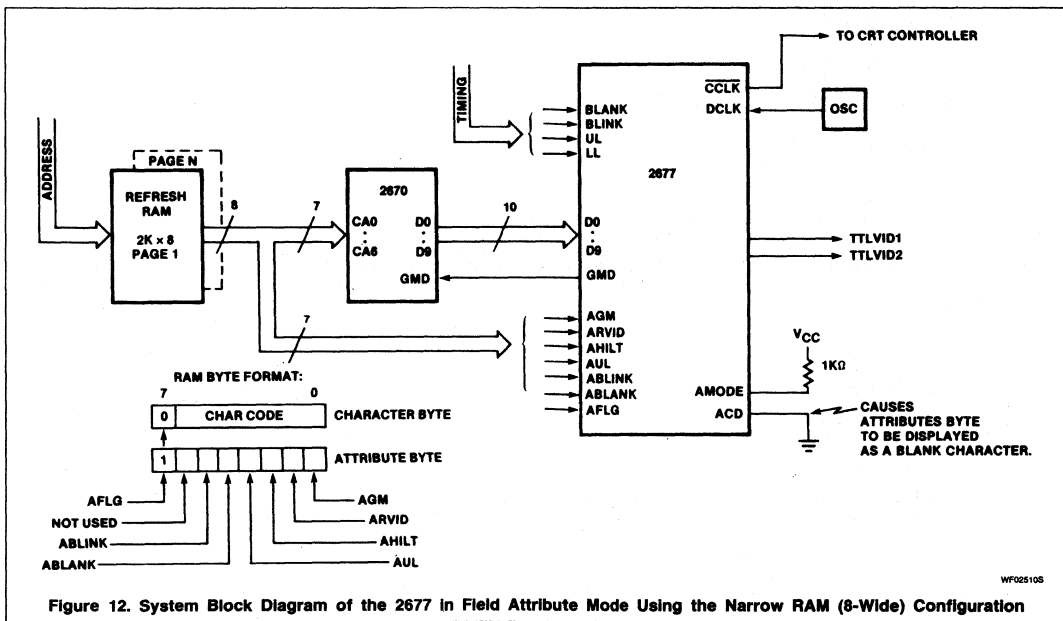
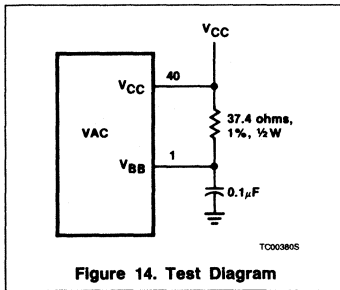
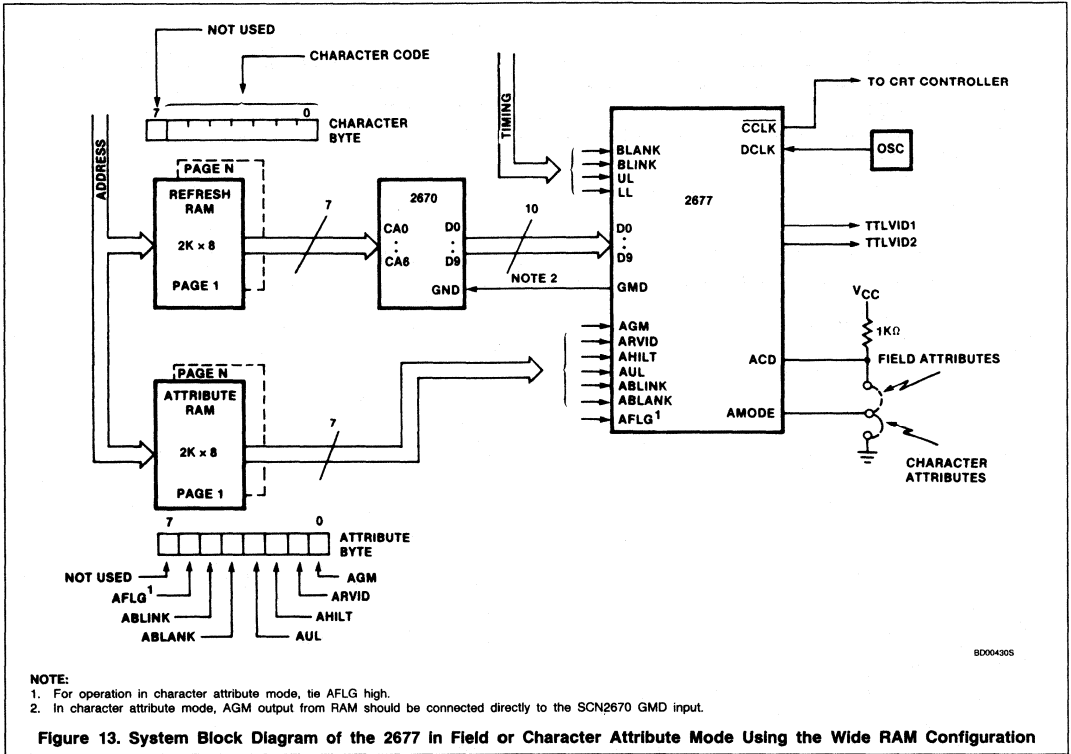

Figure 12. System Block Diagram of the 2677 in Field Attribute Mode Using the Narrow RAM (8-Wide) Configuration

# Video Attributes Controller (VAC)

## SCB2677



# SCN2681

## Dual Asynchronous Receiver/ Transmitter (DUART)

Product Specification

### Microprocessor Products

#### DESCRIPTION

The Signetics SCN2681 Dual Universal Asynchronous Receiver/Transmitter (DUART) is a single-chip MOS-LSI communications device that provides two independent full-duplex asynchronous receiver/transmitter channels in a single package. It interfaces directly with microprocessors and may be used in a polled or interrupt driven system.

The operating mode and data format of each channel can be programmed independently. Additionally, each receiver and transmitter can select its operating speed as one of eighteen fixed baud rates, a  $16\times$  clock derived from a programmable counter/timer, or an external  $1\times$  or  $16\times$  clock. The baud rate generator and counter/timer can operate directly from a crystal or from external clock inputs. The ability to independently program the operating speed of the receiver and transmitter make the DUART particularly attractive for dual-speed channel applications such as clustered terminal systems.

Each receiver is quadruply buffered to minimize the potential of receiver overrun or to reduce interrupt overhead in interrupt driven systems. In addition, a flow control capability is provided to disable a remote DUART transmitter when the buffer of the receiving device is full.

#### FEATURES

- Dual full-duplex asynchronous receiver/transmitter
- Quadruple buffered receiver data registers
- Programmable data format
  - 5 to 8 data bits plus parity
  - Odd, even, no parity or force parity
  - 1, 1.5 or 2 stop bits programmable in  $\frac{1}{16}$ -bit increments
- Programmable baud rate for each receiver and transmitter selectable from:

- 18 fixed rates: 50 to 38.4k baud
- One user-defined rate derived from programmable timer/counter
- External  $1\times$  or  $16\times$  clock
- Parity, framing, and overrun error detection
- False start bit detection
- Line break detection and generation
- Programmable channel mode
  - Normal (full-duplex)
  - Automatic echo
  - Local loopback
  - Remote loopback
- Multi-function programmable 16-bit counter/timer
- Multi-function 7-bit input port
  - Can serve as clock or control inputs
  - Change of state detection on four inputs
- Multi-function 8-bit output port
  - Individual bit set/reset capability
  - Outputs can be programmed to be status/interrupt signals
- Versatile interrupt system
  - Single interrupt output with eight maskable interrupting conditions
  - Output port can be configured to provide a total of up to six separate wire-ORable interrupt outputs
- Maximum data transfer:  $1\times - 1\text{MB/s}$ ,  $16\times - 125\text{KB/s}$
- Automatic wake-up mode for multidrop applications
- Start-end break interrupt/status
- Detects break which originates in the middle of a character
- On-chip crystal oscillator
- TTL compatible
- Single +5V power supply

#### PIN CONFIGURATIONS

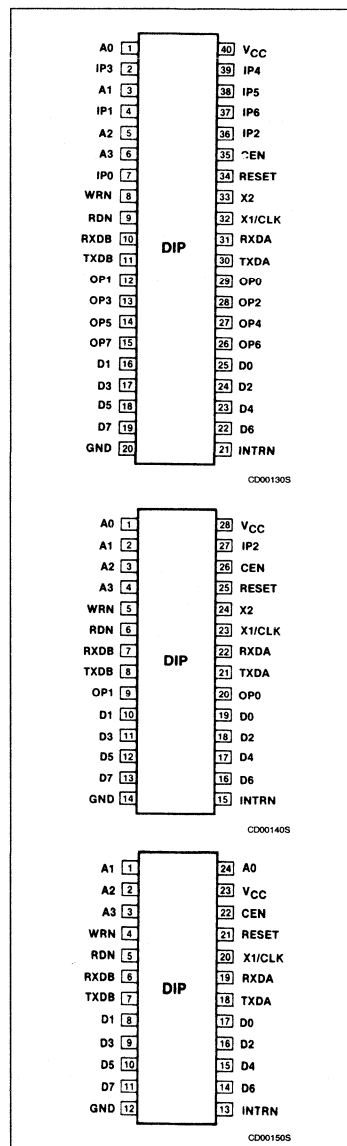

## Dual Asynchronous Receiver/Transmitter (DUART)

SCN2681

## PIN CONFIGURATIONS (Continued)

	<b>Pin</b>	<b>Function</b>	<b>Pin</b>	<b>Function</b>
	1	NC	23	NC
	2	A0	24	INTRN
	3	IP3	25	D6
	4	A1	26	D4
	5	IP1	27	D2
	6	A2	28	D0
	7	A3	29	OP6
	8	IP0	30	OP4
	9	WRN	31	OP2
	10	RDN	32	OP0
	11	RXDB	33	TXDA
	12	NC	34	NC
	13	TXDB	35	RXDA
	14	OP1	36	X1/CLK
	15	OP3	37	X2
	16	OP5	38	RESET
	17	OP7	39	CEN
	18	D1	40	IP2
	19	D3	41	IP6
	20	D5	42	IP5
	21	D7	43	IP4
22	GND	44	V <sub>CC</sub>	

Also provided on the SCN2681 are a multipurpose 7-bit input port and a multipurpose 8-bit output port. These can be used as general purpose I/O ports or can be assigned specific functions (such as clock inputs or status/interrupt outputs) under program control.

The SCN2681 is available in four package versions: 40-pin and 28-pin, both 0.6" wide DIPs; a compact 24-pin 0.4" wide DIP; and a 44-pin PLCC.

## ORDERING INFORMATION

PACKAGES	V <sub>CC</sub> = +5V ± 5%, T <sub>A</sub> = 0°C to +70°C			
	24-Pin <sup>1</sup>	28-Pin <sup>2</sup>	40-Pin <sup>2</sup>	44-Pin
Ceramic DIP	Not available	SCN2681AC1128	SCN2681AC1140	Not available
Plastic DIP	SCN2681AC1N24	SCN2681AC1N28	SCN2681AC1N40	Not available
Plastic LCC	Not available	Not available	Not available	SCN2681AC1A44

## NOTES:

1. 400 mil wide DIP
2. 600 mil wide DIP

## PIN DESCRIPTION

MNEMONIC	APPLICABLE			TYPE	NAME AND FUNCTION
	40	28	24		
D0 - D7	X	X	X	I/O	<b>Data Bus:</b> Bidirectional 3-State data bus used to transfer commands, data and status between the DUART and the CPU. D0 is the least significant bit.
CEN	X	X	X	I	<b>Chip Enable:</b> Active low input signal. When low, data transfers between the CPU and the DUART are enabled on D0 - D7 as controlled by the WRN, RDN and A0 - A3 inputs. When high, places the D0 - D7 lines in the 3-State condition.
WRN	X	X	X	I	<b>Write Strobe:</b> When low and CEN is also low, the contents of the data bus is loaded into the addressed register. The transfer occurs on the rising edge of the signal.
RDN	X	X	X	I	<b>Read Strobe:</b> When low and CEN is also low, causes the contents of the addressed register to be presented on the data bus. The read cycle begins on the falling edge of RDN.
A0 - A3	X	X	X	I	<b>Address Inputs:</b> Select the DUART internal registers and ports for read/write operations.
RESET	X	X	X	I	<b>Reset:</b> A high level clears internal registers (SRA, SRB, IMR, ISR, OPR, OPCR), puts OP0 - OP7 in the high state, stops the counter/timer, and puts channels A and B in the inactive state, with the TxDA and TxDB outputs in the mark (high) state.
INTRN	X	X	X	O	<b>Interrupt Request:</b> Active low, open drain, output which signals the CPU that one or more of the eight maskable interrupting conditions are true.
X1/CLK	X	X	X	I	<b>Crystal 1:</b> Crystal or external clock input. A crystal or clock of the specified limits must be supplied at all times. When a crystal is used, a capacitor must be connected from this pin to ground (see Figure 5).
X2	X	X		I	<b>Crystal 2:</b> Connection for other side of the crystal. When a crystal is used, a capacitor must be connected from this pin to ground (see Figure 5). If X1/CLK is driven from an external source, this pin should be grounded.
RxDA	X	X	X	I	<b>Channel A Receiver Serial Data Input:</b> The least significant bit is received first. 'Mark' is high, 'space' is low.



## Dual Asynchronous Receiver/Transmitter (DUART)

SCN2681

## PIN DESCRIPTION (Continued)

MNEMONIC	APPLICABLE			TYPE	NAME AND FUNCTION
	40	28	24		
RxDB	X	X	X	I	<b>Channel B Receiver Serial Data Input:</b> The least significant bit is received first. 'Mark' is high, 'space' is low.
TxDA	X	X	X	O	<b>Channel A Transmitter Serial Data Output:</b> The least significant bit is transmitted first. This output is held in the 'mark' condition when the transmitter is disabled, idle, or when operating in local loopback mode. 'Mark' is high, 'space' is low.
TxDB	X	X	X	O	<b>Channel B Transmitter Serial Data Output:</b> The least significant bit is transmitted first. This output is held in the 'mark' condition when the transmitter is disabled, idle, or when operating in local loopback mode. 'Mark' is high, 'space' is low.
OP0	X	X		O	<b>Output 0:</b> General purpose output, or channel A request to send (RTSAN, active low). Can be deactivated automatically on receive or transmit.
OP1	X	X		O	<b>Output 1:</b> General purpose output, or channel B request to send (RTSBN, active low). Can be deactivated automatically on receive or transmit.
OP2	X			O	<b>Output 2:</b> General purpose output, or channel A transmitter 1× or 16× clock output, or channel A receiver 1× clock output.
OP3	X			O	<b>Output 3:</b> General purpose output, or open drain, active low counter/timer output, or channel B transmitter 1× clock output, or channel B receiver 1× clock output.
OP4	X			O	<b>Output 4:</b> General purpose output, or channel A open drain, active low, RxRDYA/FFULLA output.
OP5	X			O	<b>Output 5:</b> General purpose output, or channel B open drain, active low, RxRDYB/FFULLB output.
OP6	X			O	<b>Output 6:</b> General purpose output, or channel A open drain, active low, TxRDYA output.
OP7	X			O	<b>Output 7:</b> General purpose output, or channel B open drain, active low, TxRDYB output.
IP0	X			I	<b>Input 0:</b> General purpose input, or channel A clear to send active low input (CTSAN).
IP1	X			I	<b>Input 1:</b> General purpose input, or channel B clear to send active low input (CTSBN).
IP2	X	X		I	<b>Input 2:</b> General purpose input, or counter/timer external clock input.
IP3	X			I	<b>Input 3:</b> General purpose input, or channel A transmitter external clock input (TxCA). When the external clock is used by the transmitter, the transmitted data is clocked on the falling edge of the clock.
IP4	X			I	<b>Input 4:</b> General purpose input, or channel A receiver external clock input (RxCA). When the external clock is used by the receiver, the received data is sampled on the rising edge of the clock.
IP5	X			I	<b>Input 5:</b> General purpose input, or channel B transmitter external clock input (TxCB). When the external clock is used by the transmitter, the transmitted data is clocked on the falling edge of the clock.
IP6	X			I	<b>Input 6:</b> General purpose input or channel B receiver external clock input (RxCB). When the external clock is used by the receiver, the received data is sampled on the rising edge of the clock.
V <sub>CC</sub>	X	X	X	I	<b>Power Supply:</b> +5V supply input
GND	X	X	X	I	<b>Ground</b>

# Dual Asynchronous Receiver/Transmitter (DUART)

SCN2681

## BLOCK DIAGRAM

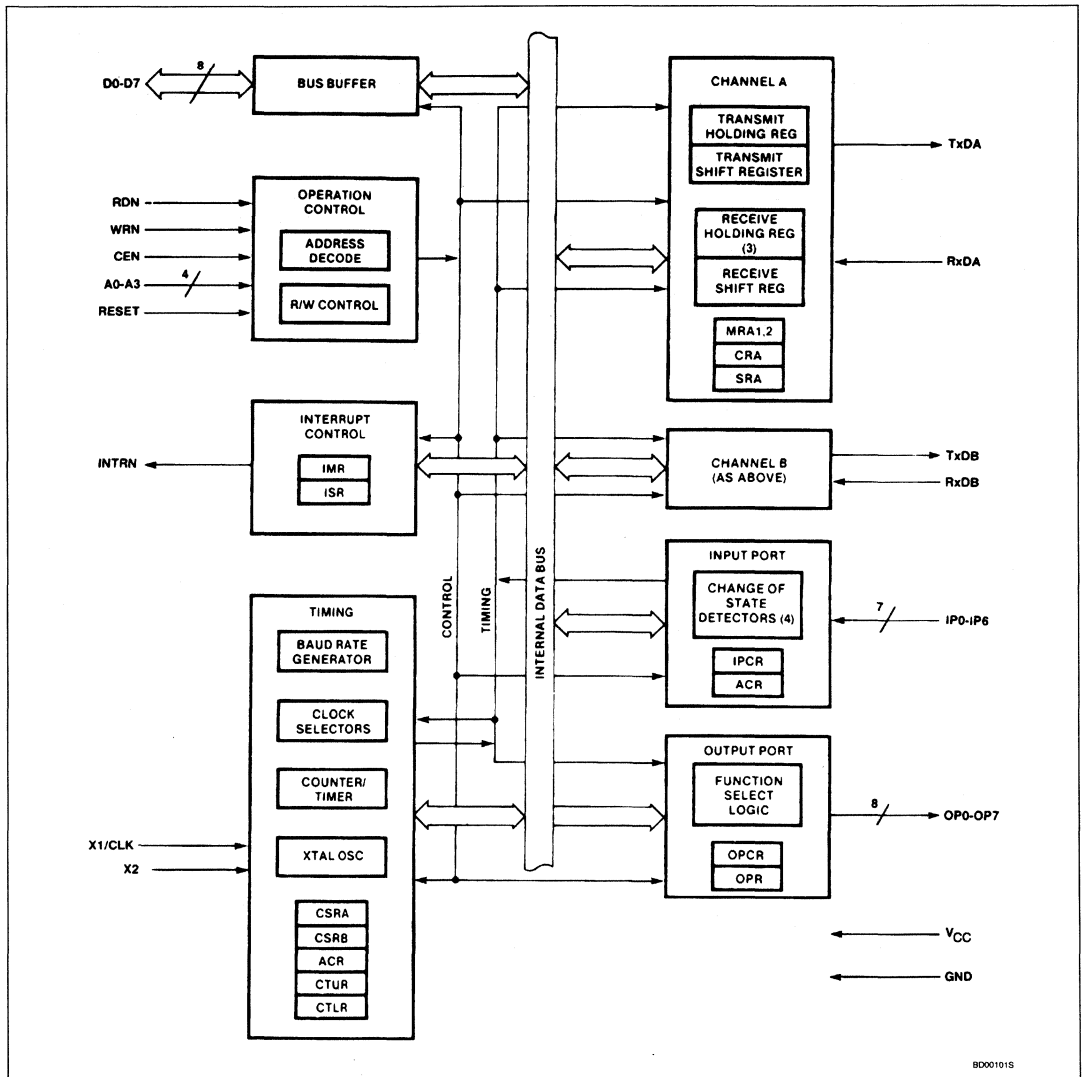

## Dual Asynchronous Receiver/Transmitter (DUART)

SCN2681

2

**BLOCK DIAGRAM**

The 2681 DUART consists of the following eight major sections: data bus buffer, operation control, interrupt control, timing, communications channels A and B, input port and output port. Refer to the block diagram.

**Data Bus Buffer**

The data bus buffer provides the interface between the external and internal data buses. It is controlled by the operation control block to allow read and write operations to take place between the controlling CPU and the DUART.

**Operation Control**

The operation control logic receives operation commands from the CPU and generates appropriate signals to internal sections to control device operation. It contains address decoding and read and write circuits to permit communications with the microprocessor via the data bus buffer.

**Interrupt Control**

A single active low interrupt output (INTRN) is provided which is activated upon the occurrence of any of eight internal events. Associated with the interrupt system are the interrupt mask register (IMR) and the interrupt status register (ISR). The IMR may be programmed to select only certain conditions to cause INTRN to be asserted. The ISR can be read by the CPU to determine all currently active interrupting conditions.

Outputs OP3–OP7 can be programmed to provide discrete interrupt outputs for the transmitters, receivers, and counter/timer.

**Timing Circuits**

The timing block consists of a crystal oscillator, a baud rate generator, a programmable 16-bit counter/timer, and four clock selectors. The crystal oscillator operates directly from a 3.6864MHz crystal connected across the X1/CLK and X2 inputs. If an external clock of the appropriate frequency is available, it may be connected to X1/CLK. The clock serves as the basic timing reference for the baud rate generator (BRG), the counter/timer, and other internal circuits. A clock signal within the limits specified in the specifications section of this data sheet must always be supplied to the DUART.

If an external is used instead of a crystal, X1 should be driven using a configuration similar to the one in Figure 5. The input clock must be capable of attaining a  $V_{IH}$  of 4.4V.

The baud rate generator operates from the oscillator or external clock input and is capable of generating 18 commonly used data communications baud rates ranging from 50 to 38.4k baud. The clock outputs from the BRG are at  $16\times$  the actual baud rate. The counter/timer can be used as a timer to

produce a  $16\times$  clock for any other baud rate by counting down the crystal clock or an external clock. The four clock selectors allow the independent selection, for each receiver and transmitter, of any of these baud rates or an external timing signal.

The counter/timer (C/T) can be programmed to use one of several timing sources as its input. The output of the C/T is available to the clock selectors and can also be programmed to be output at OP3. In the counter mode, the contents of the C/T can be read by the CPU and it can be stopped and started under program control. In the timer mode, the C/T acts as a programmable divider.

**Communications Channels A And B**

Each communications channel of the 2681 comprises a full-duplex asynchronous receiver/transmitter (UART). The operating frequency for each receiver and transmitter can be selected independently from the baud rate generator, the counter timer, or from an external input.

The transmitter accepts parallel data from the CPU, converts it to a serial bit stream, inserts the appropriate start, stop, and optional parity bits and outputs a composite serial stream of data on the TxD output pin. The receiver accepts serial data on the RxD pin, converts this serial input to parallel format, checks for start bit, stop bit, parity bit (if any), or break condition and sends an assembled character to the CPU.

**Input Port**

The input port pulse detection circuitry uses a 38.4kHz sampling clock derived from one of the baud rate generator taps. This results in a sampling period of slightly more than  $25\mu\text{s}$  (this assumes that the clock input is 3.6864MHz). The detection circuitry, in order to guarantee that a true change in level has occurred, requires two successive samples at the new logic level be observed. As a consequence, the minimum duration of the signal change is  $25\mu\text{s}$  if the transition occurs "coincident with the first sample pulse." The  $50\mu\text{s}$  time refers to the situation in which the change of state is "just missed" and the first change of state is not detected until  $25\mu\text{s}$  later.

The inputs to this unatched 7-bit port can be read by the CPU by performing a read operation at address D16. A high input results in a logic 1 while a low input results in a logic 0. D7 will always be read as a logic 1. The pins of this port can also serve as auxiliary inputs to certain portions of the DUART logic.

Four change-of-state detectors are provided which are associated with inputs IP3, IP2, IP1, and IP0. A high-to-low or low-to-high transition of these inputs, lasting longer than

$25 - 50\mu\text{s}$ , will set the corresponding bit in the input port change register. The bits are cleared when the register is read by the CPU. Any change of state can also be programmed to generate an interrupt to the CPU.

**Output Port**

The 8-bit multi-purpose output port can be used as a general purpose output port, in which case the outputs are the complements of the output port register (OPR).  $\text{OPR}[n] = 1$  results in  $\text{OP}[n] = \text{low}$  and vice versa. Bits of the OPR can be individually set and reset. A bit is set by performing a write operation at address E16 with the accompanying data specifying the bits to be set (1 = set, 0 = no change). Likewise, a bit is reset by a write at address F16 with the accompanying data specifying the bits to be reset (1 = reset, 0 = no change).

Outputs can be also individually assigned specific functions by appropriate programming of the channel A mode registers (MR1A, MR2A), the channel B mode registers (MR1B, MR2B), and the output port configuration register (OPCR).

**OPERATION****Transmitter**

The 2681 is conditioned to transmit data when the transmitter is enabled through the command register. The 2681 indicates to the CPU that it is ready to accept a character by setting the TxRDY bit in the status register. This condition can be programmed to generate an interrupt request at OP6 or OP7 and INTRN. When a character is loaded into the transmit holding register (THR), the above conditions are negated. Data is transferred from the holding register to transmit shift register when it is idle or has completed transmission of the previous character. The TxRDY conditions are then asserted again which means one full character time of buffering is provided. Characters cannot be loaded into the THR while the transmitter is disabled.

The transmitter converts the parallel data from the CPU to a serial bit stream on the TxD output pin. It automatically sends a start bit followed by the programmed number of data bits, an optional parity bit, and the programmed number of stop bits. The least significant bit is sent first. Following the transmission of the stop bits, if a new character is not available in the THR, the TxD output remains high and the TxEMT bit in the status register (SR) will be set to 1. Transmission resumes and the TxEMT bit is cleared when the CPU loads a new character into the THR. If the transmitter is disabled, it continues operating until the character currently being transmitted is completely sent out. The trans-

## Dual Asynchronous Receiver/Transmitter (DUART)

SCN2681

mitter can be forced to send a continuous low condition by issuing a send break command.

The transmitter can be reset through a software command. If it is reset, operation ceases immediately and the transmitter must be enabled through the command register before resuming operation. If CTS operation is enabled, the CTSN input must be low in order for the character to be transmitted. If it goes high in the middle of a transmission, the character in the shift register is transmitted and TxDA then remains in the marking state until CTSN goes low. The transmitter can also control the deactivation of the RTSN output. If programmed, the RTSN output will be reset one bit time after the character in the transmit shift register and transmit holding register (if any) are completely transmitted; only if the transmitter has been disabled.

### Receiver

The 2681 is conditioned to receive data when enabled through the command register. The receiver looks for a high-to-low (mark-to-space) transition of the start bit on the RxD input pin. If a transition is detected, the state of the RxD pin is sampled each  $16 \times$  clock for  $7\frac{1}{2}$  clocks ( $16 \times$  clock mode) or at the next rising edge of the bit time clock ( $1 \times$  clock mode). If RxD is sampled high, the start bit is invalid and the search for a valid start bit begins again. If RxD is still low, a valid start bit is assumed and the receiver continues to sample the input at one bit time intervals at the theoretical center of the bit, until the proper number of data bits and the parity bit (if any) have been assembled, and one stop bit has been detected. The least significant bit is received first. The data is then transferred to the receive holding register (RHR) and the RxRDY bit in the SR is set to a 1. This condition can be programmed to generate an interrupt at OP4 or OP5 and INTRN. If the character length is less than eight bits, the most significant unused bits in the RHR are set to zero.

After the stop bit is detected, the receiver will immediately look for the next start bit. However, if a non-zero character was received without a stop bit (framing error) and RxD remains low for one half of the bit period after the stop bit was sampled, then the receiver operates as if a new start bit transition had been detected at that point (one-half bit time after the stop bit was sampled).

The parity error, framing error, overrun error and received break state (if any) are strobed into the SR at the received character boundary before the RxRDY status bit is set. If a break condition is detected (RxD is low for the entire character including the stop bit), a character consisting of all zeros will be loaded into the RHR and the received break bit in the SR is set to 1. The RxD input must return

to a high condition for at least one-half bit time before a search for the next start bit begins.

The RHR consists of a first-in-first-out (FIFO) stack with a capacity of three characters. Data is loaded from the receive shift register into the topmost empty position of the FIFO. The RxRDY bit in the status register is set whenever one or more characters are available to be read, and a FFULL status bit is set if all three stack positions are filled with data. Either of these bits can be selected to cause an interrupt. A read of the RHR outputs the data at the top of the FIFO. After the read cycle, the data FIFO and its associated status bits (see below) are 'popped', thus emptying a FIFO position for new data.

In addition to the data word, three status bits (parity error, framing error, and received break) are also appended to each data character in the FIFO (overrun is not). Status can be provided in two ways, as programmed by the error mode control bit in the mode register. In the 'character' mode, status is provided on a character-by-character basis; the status applies only to the character at the top of the FIFO. In the 'block' mode, the status provided in the SR for these three bits is the logical-OR of the status for all characters coming to the top of the FIFO since the last 'reset error' command was issued. In either mode reading the SR does not affect the FIFO. The FIFO is 'popped' only when the RHR is read. Therefore the status register should be read prior to reading the FIFO.

If the FIFO is full when a new character is received, that character is held in the receive shift register until a FIFO position is available. If an additional character is received while this state exists, the contents of the FIFO are not affected; the character previously in the shift register is lost and the overrun error status bit (SR[4]) will be set-upon receipt of the start bit of the new (overrunning) character.

The receiver can control the deactivation of RTS. If programmed to operate in this mode, the RTSN output will be negated when a valid start bit was received and the FIFO is full. When a FIFO position becomes available, the RTSN output will be re-asserted automatically. This feature can be used to prevent an overrun, in the receiver, by connecting the RTSN output to the CTSN input of the transmitting device.

If the receiver is disabled, the FIFO characters can be read. However, no additional characters can be received until the receiver is enabled again. If the receiver is reset, the FIFO and all of the receiver status, and the corresponding output ports and interrupt are reset. No additional characters can be received until the receiver is enabled again.

### Multidrop Mode

The DUART is equipped with a wake up mode used for multidrop applications. This mode is selected by programming bits MR1A[4:3] or MR1B[4:3] to '11' for channels A and B, respectively. In this mode of operation, a 'master' station transmits an address character followed by data characters for the addressed 'slave' station. The slave stations, with receivers that are normally disabled, examine the received data stream and 'wake-up' the CPU (by setting RxRDY) only upon receipt of an address character. The CPU compares the received address to its station address and enables the receiver if it wishes to receive the subsequent data characters. Upon receipt of another address character, the CPU may disable the receiver to initiate the process again.

A transmitted character consists of a start bit, the programmed number of data bits, an address/data (A/D) bit, and the programmed number of stop bits. The polarity of the transmitted A/D bit is selected by the CPU by programming bit MR1A[2]/MR1B[2]. MR1A[2]/MR1B[2] = 0 transmits a zero in the A/D bit position, which identifies the corresponding data bits as data, while MR1A[2]/MR1B[2] = 1 transmits a one in the A/D bit position, which identifies the corresponding data bits as an address. The CPU should program the mode register prior to loading the corresponding data bits into the THR.

In this mode, the receiver continuously looks at the received data stream, whether it is enabled or disabled. If disabled, it sets the RxRDY status bit and loads the character into the RHR FIFO if the received A/D bit is a one (address tag), but discards the received character if the received A/D bit is a zero (data tag). If enabled, all received characters are transferred to the CPU via the RHR. In either case, the data bits are loaded into the data FIFO while the A/D bit is loaded into the status FIFO position normally used for parity error (SRA[5] or SRB[5]). Framing error, overrun error, and break detect operate normally whether or not the receiver is enabled.

### PROGRAMMING

The operation of the DUART is programmed by writing control words into the appropriate registers. Operational feedback is provided via status registers which can be read by the CPU. The addressing of the registers is described in Table 1.

The contents of certain control registers are initialized to zero on RESET. Care should be exercised if the contents of a register are changed during operation, since certain changes may cause operational problems.

## Dual Asynchronous Receiver/Transmitter (DUART)

SCN2681

Table 1. 2681 Register Addressing

A3	A2	A1	A0	READ (RDN = 0)	WRITE (WRN = 0)
0	0	0	0	Mode Register A (MR1A, MR2A)	Mode Register A (MR1A, MR2A)
0	0	0	1	Status Register A (SRA)	Clock Select Reg. A (CSRA)
0	0	1	0	*Reserved*	Command Register A (CRA)
0	0	1	1	Rx Holding Register A (RHRA)	Tx Holding Register A (THRA)
0	1	0	0	Input Port Change Reg. (IPCR)	Aux. Control Register (ACR)
0	1	0	1	Interrupt Status Reg. (ISR)	Interrupt Mask Reg. (IMR)
0	1	1	0	Counter/Timer Upper (CTU)	C/T Upper Register (CTUR)
0	1	1	1	Counter/Timer Lower (CTL)	C/T Lower Register (CTLR)
1	0	0	0	Mode Register B (MR1B, MR2B)	Mode Register B (MR1B, MR2B)
1	0	0	1	Status Register B (SRB)	Clock Select Reg. B (CSRB)
1	0	1	0	*Reserved*	Command Register B (CRB)
1	0	1	1	Rx Holding Register B (RHRB)	Tx Holding Register B (THRB)
1	1	0	0	*Reserved*	*Reserved*
1	1	0	1	Input Port	Output Port Conf. Reg. (OPCR)
1	1	1	0	Start Counter Command	Set Output Port Bits Command
1	1	1	1	Stop Counter Command	Reset Output Port Bits Command

For example, changing the number of bits per character while the transmitter is active may cause the transmission of an incorrect character. In general, the contents of the MR, the CSR, and the OPCR should only be changed while the receiver(s) and transmitter(s) are not enabled, and certain changes to the ACR should only be made while the C/T is stopped.

Mode registers 1 and 2 of each channel are accessed via independent auxiliary pointers. The pointer is set to MR1x by RESET or by issuing a 'reset pointer' command via the corresponding command register. Any read or write of the mode register while the pointer is at MR1x, switches the pointer to MR2x. The pointer then remains at MR2x, so that subsequent accesses are always to MR2x

unless the pointer is reset to MR1x as described above.

Mode, command, clock select, and status registers are duplicated for each channel to provide total independent operation and control. Refer to Table 2 for register bit descriptions. The reserved registers at addresses H'02' and H'0A' should never be read during normal operation since they are reserved for internal diagnostics.

### MR1A — Channel A Mode Register 1

MR1A is accessed when the channel A MR pointer points to MR1. The pointer is set to MR1 by RESET or by a 'set pointer' command applied via CRA. After reading or writing MR1A, the pointer will point to MR2A.

### MR1A[7] — Channel A Receiver Request-to-Send Control

This bit controls the deactivation of the RTSAN output (OP0) by the receiver. This output is normally asserted by setting OPR[0] and negated by resetting OPR[0]. MR 1A[7] = 1 causes RTSAN to be negated upon receipt of a valid start bit if the channel A FIFO is full. However, OPR[0] is not reset and RTSAN will be asserted again when an empty FIFO position is available. This feature can be used for flow control to prevent overrun in the receiver by using the RTSAN output signal to control the CTSN input of the transmitting device.

### MR1A[6] — Channel A Receiver Interrupt Select

This bit selects either the channel A receiver ready status (RxRDY) or the channel A FIFO full status (FFULL) to be used for CPU interrupts. It also causes the selected bit to be output on OP4 if it is programmed as an interrupt output via the OPCR.

### MR1A[5] — Channel A Error Mode Select

This bit selects the operating mode of the three FIFOed status bits (FE, PE, received break) for channel A. In the 'character' mode, status is provided on a character-by-character basis; the status applies only to the character at the top of the FIFO. In the 'block' mode, the status provided in the SR for these bits is the accumulation (logical-OR) of the status for all characters coming to the top of the FIFO since the last 'reset error' command for channel A was issued.

Table 2. Register Bit Formats

	BIT 7	BIT 6	BIT 5	BIT 4	BIT 3	BIT 2	BIT 1	BIT 0
	RxRTS CONTROL	RxINT SELECT	ERROR MODE	PARITY MODE		PARITY TYPE		BITS PER CHARACTER
MR1A	0 = no	0 = RxRDY	0 = char	00 = with parity		0 = even		00 = 5
MR1B	1 = yes	1 = FFULL	1 = block	01 = force parity		1 = odd		01 = 6
				10 = no parity				10 = 7
				11 = multi-drop mode				11 = 8

	BIT 7	BIT 6	BIT 5	BIT 4	BIT 3	BIT 2	BIT 1	BIT 0
	CHANNEL MODE	TxRTS CONTROL	CTS ENABLE Tx			STOP BIT LENGTH*		
MR2A	00 = Normal	0 = no	0 = no	0 = 0.563	4 = 0.813	8 = 1.563		C = 1.813
MR2B	01 = Auto-echo	1 = yes	1 = yes	1 = 0.625	5 = 0.875	9 = 1.625		D = 1.875
	10 = Local loop			2 = 0.688	6 = 0.938	A = 1.688		E = 1.938
	11 = Remote loop			3 = 0.750	7 = 1.000	B = 1.750		F = 2.000

## NOTE:

\*Add 0.5 to values shown for 0-7 if channel is programmed for 5 bits/char.

## Dual Asynchronous Receiver/Transmitter (DUART)

SCN2681

Table 2. Register Bit Formats (Continued)

	BIT 7	BIT 6	BIT 5	BIT 4	BIT 3	BIT 2	BIT 1	BIT 0
CSRA CSRB	RECEIVER CLOCK SELECT				TRANSMITTER CLOCK SELECT			
	See Text				See Text			

	BIT 7	BIT 6	BIT 5	BIT 4	BIT 3	BIT 2	BIT 1	BIT 0
CRA CRB		MISCELLANEOUS COMMANDS			DISABLE Tx	ENABLE Tx	DISABLE Rx	ENABLE Rx
	Not used – must be 0	See Text			0 = no 1 = yes	0 = no 1 = yes	0 = no 1 = yes	0 = no 1 = yes

	BIT 7	BIT 6	BIT 5	BIT 4	BIT 3	BIT 2	BIT 1	BIT 0
SRA SRB	RECEIVED BREAK	FRAMING ERROR	PARITY ERROR	OVERRUN ERROR	TxEMT	TxRDY	FFULL	RxRDY
	0 = no 1 = yes	0 = no 1 = yes	0 = no 1 = yes	0 = no 1 = yes	0 = no 1 = yes	0 = no 1 = yes	0 = no 1 = yes	0 = no 1 = yes

## NOTE:

\*These status bits are appended to the corresponding data character in the receive FIFO. A read of the status register provides these bits (7:5) from the top of the FIFO together with bits (4:0). These bits are cleared by a 'reset error status' command. In character mode they are discarded when the corresponding data character is read from the FIFO.

	BIT 7	BIT 6	BIT 5	BIT 4	BIT 3	BIT 2	BIT 1	BIT 0
OPCR	OP7	OP6	OP5	OP4	OP3		OP2	
	0 = OPR[7] 1 = TxRDYB	0 = OPR[6] 1 = TxRDYA	0 = OPR[5] 1 = RxRDY/ FFULLB	0 = OPR[4] 1 = RxRDY/ FFULLA	00 = OPR[3] 01 = C/T OUTPUT 10 = TxCB(1×) 11 = RxCB(1×)	00 = OPR[2] 01 = TxCA(1×) 10 = TxCA(1×) 11 = RxCA(1×)		

	BIT 7	BIT 6	BIT 5	BIT 4	BIT 3	BIT 2	BIT 1	BIT 0
ACR	BRG SET SELECT	COUNTER/TIMER MODE AND SOURCE			DELTA IP3 INT	DELTA IP2 INT	DELTA IP1 INT	DELTA IP0 INT
	0 = set1 1 = set2	See Table 4			0 = off 1 = on	0 = off 1 = on	0 = off 1 = on	0 = off 1 = on

	BIT 7	BIT 6	BIT 5	BIT 4	BIT 3	BIT 2	BIT 1	BIT 0
IPCR	DELTA IP3	DELTA IP2	DELTA IP1	DELTA IP0	IP3	IP2	IP1	IP0
	0 = no 1 = yes	0 = no 1 = yes	0 = no 1 = yes	0 = no 1 = yes	0 = low 1 = high	0 = low 1 = high	0 = low 1 = high	0 = low 1 = high

	BIT 7	BIT 6	BIT 5	BIT 4	BIT 3	BIT 2	BIT 1	BIT 0
ISR	INPUT PORT CHANGE	DELTA BREAK B	RxRDY/FFULLB	TxRDYB	COUNTER READY	DELTA BREAK A	RxRDY/FFULLA	TxRDYA
	0 = no 1 = yes	0 = no 1 = yes	0 = no 1 = yes	0 = no 1 = yes	0 = no 1 = yes	0 = no 1 = yes	0 = no 1 = yes	0 = no 1 = yes

## Dual Asynchronous Receiver/Transmitter (DUART)

SCN2681

Table 2. Register Bit Formats (Continued)

	BIT 7	BIT 6	BIT 5	BIT 4	BIT 3	BIT 2	BIT 1	BIT 0
IMR	IN. PORT CHANGE INT	DELTA BREAK B INT	RxRDY/FFULLB INT	TxRDYB INT	COUNTER READY INT	DELTA BREAK A INT	RxRDY/FFULLA INT	TxRDYA INT
	0 = off 1 = on	0 = off 1 = on	0 = off 1 = on	0 = off 1 = on	0 = off 1 = on	0 = off 1 = on	0 = off 1 = on	0 = off 1 = on
CTUR	C/T[15]	C/T[14]	C/T[13]	C/T[12]	C/T[11]	C/T[10]	C/T[9]	C/T[8]
CTLR	C/T[7]	C/T[6]	C/T[5]	C/T[4]	C/T[3]	C/T[2]	C/T[1]	C/T[0]

**MR1A[4:3] — Channel A Parity Mode Select**

If 'with parity' or 'force parity' is selected, a parity bit is added to the transmitted character and the receiver performs a parity check on incoming data. MR1A[4:3] = 11 selects channel A to operate in the special multidrop mode described in the Operation section.

**MR1A[2] — Channel A Parity Type Select**

This bit selects the parity type (odd or even) if the 'with parity' mode is programmed by MR1A[4:3], and the polarity of the forced parity bit if the 'force parity' mode is programmed. It has no effect if the 'no parity' mode is programmed. In the special multidrop mode it selects the polarity of the A/D bit.

**MR1A[1:0] — Channel A Bits Per Character Select**

This field selects the number of data bits per character to be transmitted and received. The character length does not include the start, parity, and stop bits.

**MR2A — Channel A Mode Register 2**

MR2A is accessed when the channel A MR pointer points to MR2, which occurs after any access to MR1A. Accesses to MR2A do not change the pointer.

**MR2A[7:6] — Channel A Mode Select**

Each channel of the DUART can operate in one of four modes. MR2A[7:6] = 00 is the normal mode, with the transmitter and receiver operating independently. MR2A[7:6] = 01 places the channel in the automatic echo mode, which automatically retransmits the received data. The following conditions are true while in automatic echo mode:

1. Received data is relocked and retransmitted on the TxDA output.
2. The receive clock is used for the transmitter.
3. The receiver must be enabled, but the transmitter need not be enabled.
4. The channel A TxRDY and TxEMT status bits are inactive.
5. The received parity is checked, but is not regenerated for transmission; i.e., transmitted parity bit is as received.
6. Character framing is checked, but the stop bits are retransmitted as received.
7. A received break is echoed as received until the next valid start bit is detected.
8. CPU to receiver communication continues normally, but the CPU to transmitter link is disabled.
3. Received data is not sent to the local CPU, and the error status conditions are inactive.
4. The received parity is not checked and is not regenerated for transmission, i.e., transmitted parity bit is as received.
5. The receiver must be enabled.
6. Character framing is not checked, and the stop bits are retransmitted as received.
7. A received break is echoed as received until the next valid start bit is detected.

The user must exercise care when switching into and out of the various modes. The selected mode will be activated immediately upon mode selection, even if this occurs in the middle of a received or transmitted character. Likewise, if a mode is deselected, the device will switch out of the mode immediately. An exception to this is switching out of autoecho or remote loopback modes: if the de-selection occurs just after the receiver has sampled the stop bit (indicated in autoecho by assertion of RxRDY), and the transmitter is enabled, the transmitter will remain in autoecho mode until the entire stop bit has been retransmitted.

**MR2A[5] — Channel A Transmitter Request-to-Send Control**

This bit controls the deactivation of the RTSAN output (OP0) by the transmitter. This output is normally asserted by setting OPR[0] and negated by resetting OPR[0]. MR2A[5] = 1 causes OPR[0] to be reset automatically one bit time after the characters in the channel A transmit shift register and in the THR, if any, are completely transmitted, including the programmed number of stop bits, if the transmitter is not enabled. This feature can be used to automatically termi-

Two diagnostic modes can also be configured. MR2A[7:6] = 10 selects local loopback mode. In this mode:

1. The transmitter output is internally connected to the receiver input.
2. The transmit clock is used for the receiver.
3. The TxDA output is held high.
4. The RxDA input is ignored.
5. The transmitter must be enabled, but the receiver need not be enabled.
6. CPU to transmitter and receiver communications continue normally.

The second diagnostic mode is the remote loopback mode, selected by MR2A[7:6] = 11. In this mode:

1. Received data is relocked and retransmitted on the TxDA output.
2. The receive clock is used for the transmitter.

## Dual Asynchronous Receiver/Transmitter (DUART)

SCN2681

nate the transmission of a message as follows:

1. Program auto-reset mode: MR2A[5] = 1.
2. Enable transmitter.
3. Assert RTSAN: OPR[0] = 1.
4. Send message.
5. Verify the message is sent by waiting until the transmit ready status (TxRDY) is asserted. Disable transmitter after the last character is loaded into the channel A THR.
6. The last character will be transmitted and OPR[0] will be reset one bit time after the last stop bit, causing RTSAN to be negated.

**MR2A[4] — Channel A Clear-to-send Control**

If this bit is 0, CTSAN has no effect on the transmitter. If this bit is a 1, the transmitter checks the state of CTSAN (IP0) each time it is ready to send a character. If IP0 is asserted (low), the character is transmitted. If it is negated (high), the TxDA output remains in the marking state and the transmission is delayed until CTSAN goes low. Changes in CTSAN while a character is being transmitted do not affect the transmission of that character.

**MR2A[3:0] — Channel A Stop Bit Length Select**

This field programs the length of the stop bit appended to the transmitted character. Stop bit lengths of  $\frac{1}{16}$  to 1 and  $1\frac{1}{16}$  to 2 bits, in increments of  $\frac{1}{16}$  bit, can be programmed for character lengths of 6, 7, and 8 bits. For a character length of 5 bits,  $1\frac{1}{16}$  to 2 stop bits can be programmed in increments of  $\frac{1}{16}$ -bit. The receiver only checks for a 'mark' condition at the center of the first stop bit position (one bit time after the last data bit, or after the parity bit if parity is enabled) in all cases.

If an external  $1\times$  clock is used for the transmitter, MR2A[3] = 0 selects one stop bit and MR2A[3] = 1 selects two stop bits to be transmitted.

**MR1B — Channel B Mode Register 1**

MR1B is accessed when the channel B MR pointer points to MR1. The pointer is set to MR1 by RESET or by a 'set pointer' command applied via CRB. After reading or writing MR1B, the pointer will point to MR2B.

The bit definitions for this register are identical to the bit definitions for MR1A, except that all control actions apply to the channel B receiver and transmitter and the corresponding inputs and outputs.

**MR2B — Channel B Mode Register 2**

MR2B is accessed when the channel B MR pointer points to MR2, which occurs after any access to MR1B. Accesses to MR2B do not change the pointer.

The bit definitions for this register are identical to the bit definitions for MR2A, except that all control actions apply to the channel B receiver and transmitter and the corresponding inputs and outputs.

**CSRA — Channel A Clock Select Register****CSRA[7:4] — Channel A Receiver Clock Select**

This field selects the baud rate clock for the channel A receiver as follows:

CSRA[7:4]	Baud Rate	
	ACR[7] = 0	ACR[7] = 1
0 0 0 0	50	75
0 0 0 1	110	110
0 0 1 0	134.5	134.5
0 0 1 1	200	150
0 1 0 0	300	300
0 1 0 1	600	600
0 1 1 0	1,200	1,200
0 1 1 1	1,050	2,000
1 0 0 0	2,400	2,400
1 0 0 1	4,800	4,800
1 0 1 0	7,200	1,800
1 0 1 1	9,600	9,600
1 1 0 0	38.4k	19.2k
1 1 0 1	Timer	Timer
1 1 1 0	IP4 — $16\times$	IP4 — $16\times$
1 1 1 1	IP4 — $1\times$	IP4 — $1\times$

The receiver clock is always a  $16\times$  clock except for CSRA[7:4] = 1111.

**CSRA[3:0] — Channel A Transmitter Clock Select**

This field selects the baud rate clock for the channel A transmitter. The field definition is as per CSRA[7:4] except as follows:

CSRA[3:0]	Baud Rate	
	ACR[7] = 0	ACR[7] = 1
1 1 1 0	IP3 — $16\times$	IP3 — $16\times$
0 1 1 1	IP3 — $1\times$	IP3 — $1\times$

The transmitter clock is always a  $16\times$  clock except for CSRA[3:0] = 1111.

**CSRB — Channel B Clock Select Register****CSRB[7:4] — Channel B Receiver Clock Select**

This field selects the baud rate clock for the channel B receiver. The field definition is as per CSRA[7:4] except as follows:

CSRB[7:4]	Baud Rate	
	ACR[7] = 0	ACR[7] = 1
1 1 1 0	IP6 — $16\times$	IP6 — $16\times$
0 1 1 1	IP6 — $1\times$	IP6 — $1\times$

The receiver clock is always a  $16\times$  clock except for CSRB[7:4] = 1111.

**CSRB[3:0] — Channel B Transmitter Clock Select**

This field selects the baud rate clock for the channel B transmitter. The field definition is as per CSRA[7:4] except as follows:

CSRB[3:4]	Baud Rate	
	ACR[7] = 0	ACR[7] = 1
1 1 1 0	IP5 — $16\times$	IP5 — $16\times$
1 1 1 1	IP5 — $1\times$	IP5 — $1\times$

The transmitter clock is always a  $16\times$  clock except for CSRB[3:0] = 1111.

**CRA — Channel A Command Register**

CRA is a register used to supply commands to channel A. Multiple commands can be specified in a single write to CRA as long as the commands are non-conflicting, e.g., the 'enable transmitter' and 'reset transmitter' commands cannot be specified in a single command word.

**CRA[6:4] — Channel A Miscellaneous Commands**

The encoded value of this field may be used to specify a single command as follows:

**CRA[6:4] COMMAND**

- |       |  |
|-------|--|
| 0 0 0 | No command.  |
| 0 0 1 | Reset MR pointer. Causes the channel A MR pointer to point to MR1.   |
| 0 1 0 | Reset receiver. Resets the channel A receiver as if a hardware reset had been applied. The receiver is disabled and the FIFO is reset.   |
| 0 1 1 | Reset transmitter. Resets the channel A transmitter as if a hardware reset had been applied.   |
| 1 0 0 | Reset error status. Clears the channel A Received Break, Parity Error, Framing Error, and Overrun Error bits in the status register (SRA[7:4]). Used in character mode to clear OE status (although RB, PE, and FE bits will also be cleared) and in block mode to clear all error status after a block of data has been received. |
| 1 0 1 | Reset channel A break change interrupt. Causes the channel A break detect change bit in the interrupt status register (ISR[2]) to be cleared to zero.  |



## Dual Asynchronous Receiver/Transmitter (DUART)

SCN2681

2

**CRA[6:4] COMMAND**

- 1 1 0 Start break. Forces the TxDA output low (spacing). If the transmitter is empty the start of the break condition will be delayed up to two bit times. If the transmitter is active the break begins when transmission of the character is completed. If a character is in the THR, the start of the break will be delayed until that character, or any others loaded subsequently are transmitted. The transmitter must be enabled for this command to be accepted.
- 1 1 1 Stop Break. The TxDA line will go high (marking) within two bit times. TxDA will remain high for one bit time before the next character, if any, is transmitted.

**CRA[3] — Disable Channel A Transmitter**  
This command terminates transmitter operation and resets the TxRDY and TxEMT status bits. However, if a character is being transmitted or if a character is in the THR when the transmitter is disabled, the transmission of the character(s) is completed before assuming the inactive state.

**CRA[2] — Enable Channel A Transmitter**  
Enables operation of the channel A transmitter. The TxRDY status bit will be asserted.

**CRA[1] — Disable Channel A Receiver**  
This command terminates operation of the receiver immediately — a character being received will be lost. The command has no effect on the receiver status bits or any other control registers. If the special multidrop mode is programmed, the receiver operates even if it is disabled. See Operation section.

**CRA[0] — Enable Channel A Receiver**  
Enables operation of the channel A receiver. If not in the special wakeup mode, this also forces the receiver into the search for start-bit state.

**CRB — Channel B Command Register**

CRB is a register used to supply commands to channel B. Multiple commands can be specified in a single write to CRB as long as the commands are non-conflicting, e.g., the 'enable transmitter' and 'reset transmitter' commands cannot be specified in a single command word.

The bit definitions for this register are identical to the bit definitions for CRA, except that all control actions apply to the channel B receiver and transmitter and the corresponding inputs and outputs.

**SRA — Channel A Status Register****SRA[7] — Channel A Received Break**

This bit indicates that an all zero character of the programmed length has been received without a stop bit. Only a single FIFO position is occupied when a break is received: further entries to the FIFO are inhibited until the RxDA line returns to the marking state for at least one-half a bit time (two successive edges of the internal or external  $1 \times$  clock).

When this bit is set, the channel A 'change in break' bit in the ISR (ISR[2]) is set. ISR[2] is also set when the end of the break condition, as defined above, is detected.

The break detect circuitry can detect breaks that originate in the middle of a received character. However, if a break begins in the middle of a character, it must persist until at least the end of the next character time in order for it to be detected.

**SRA[6] — Channel A Framing Error**

This bit, when set, indicates that a stop bit was not detected when the corresponding data character in the FIFO was received. The stop bit check is made in the middle of the first stop bit position.

**SRA[5] — Channel A Parity Error**

This bit is set when the 'with parity' or 'force parity' mode is programmed and the corresponding character in the FIFO was received with incorrect parity.

In the special multidrop mode the parity error bit stores the received A/D bit.

**SRA[4] — Channel A Overrun Error**

This bit, when set, indicates that one or more characters in the received data stream have been lost. It is set-upon receipt of a new character when the FIFO is full and a character is already in the receive shift register waiting for an empty FIFO position. When this occurs, the character in the receive shift register (and its break detect, parity error and framing error status, if any) is lost.

This bit is cleared by a 'reset error status' command.

**SRA[3] — Channel A Transmitter Empty (TxEMTA)**

This bit will be set when the channel A transmitter underruns, i.e., both the transmit holding register (THR) and the transmit shift register are empty. It is set after transmission of the last stop bit of a character if no character is in the THR awaiting transmission. It is reset when the THR is loaded by the CPU or when the transmitter is disabled.

**SRA[2] — Channel A Transmitter Ready (TxRDYA)**

This bit, when set, indicates that the THR is empty and ready to be loaded with a charac-

ter. This bit is cleared when the THR is loaded by the CPU and is set when the character is transferred to the transmit shift register. TxRDY is reset when the transmitter is disabled and is set when the transmitter is first enabled, viz., characters loaded into the THR while the transmitter is disabled will not be transmitted.

**SRA[1] — Channel A FIFO Full (FFULLA)**

This bit is set when a character is transferred from the receive shift register to the receive FIFO and the transfer causes the FIFO to become full, i.e., all three FIFO positions are occupied. It is reset when the CPU reads the RHR. If a character is waiting in the receive shift register because the FIFO is full, FFULL will not be reset when the CPU reads the RHR.

**SRA[0] — Channel A Receiver Ready (RxRDYA)**

This bit indicates that a character has been received and is waiting in the FIFO to be read by the CPU. It is set when the character is transferred from the receive shift register to the FIFO and reset when the CPU reads the RHR, only if (after this read) there are no more characters still in the FIFO.

**SRB — Channel B Status Register**

The bit definitions for this register are identical to the bit definitions for SRA, except that all status applies to the channel B receiver and transmitter and the corresponding inputs and outputs.

**OPCR — Output Port Configuration Register****OPCR[7] — OP7 Output Select**

This bit programs the OP7 output to provide one of the following:

—The complement of OPR[7]

—The channel B transmitter interrupt output, which is the complement of TxRDYB. When in this mode OP7 acts as an open-drain output. Note that this output is not masked by the contents of the IMR.

**OPCR[6] — OP6 Output Select**

This bit programs the OP6 output to provide one of the following:

—The complement of OPR[6]

—The channel A transmitter interrupt output, which is the complement of TxRDYA. When in this mode OP6 acts as an open-drain output. Note that this output is not masked by the contents of the IMR.

**OPCR[5] — OP5 Output Select**

This bit programs the OP5 output to provide one of the following:

—The complement of OPR[5]

## Dual Asynchronous Receiver/Transmitter (DUART)

SCN2681

—The channel B receiver interrupt output, which is the complement of ISR[5]. When in this mode OP5 acts as an open-drain output. Note that this output is not masked by the contents of the IMR.

**OPCR[4] — OP4 Output Select**

This bit programs the OP4 output to provide one of the following:

—The complement of OPR[4]

—The channel A receiver interrupt output, which is the complement of ISR[1]. When in this mode OP4 acts as an open-drain output. Note that this output is not masked by the contents of the IMR.

**OPCR[3:2] — OP3 Output Select**

This field programs the OP3 output to provide one of the following:

—The complement of OPR[3]

—The counter/timer output, in which case OP3 acts as an open-drain output. In the timer mode, this output is a square wave at the programmed frequency. In the counter mode, the output remains high until terminal count is reached, at which time it goes low. The output returns to the high state when the counter is stopped by a stop counter command. Note that this output is not masked by the contents of the IMR.

—The  $1 \times$  clock for the channel B transmitter, which is the clock that shifts the transmitted data. If data is not being transmitted, a free running  $1 \times$  clock is output.

—The  $1 \times$  clock for the channel B receiver, which is the clock that samples the received data. If data is not being received, a free running  $1 \times$  clock is output.

**OPCR[1:0] — OP2 Output Select**

This field programs the OP2 output to provide one of the following:

—The complement of OPR[2]

—The  $16 \times$  clock for the channel A transmitter. This is the clock selected by CSRA[3:0], and will be a  $1 \times$  clock if CSRA[3:0] = 1111.

—The  $1 \times$  clock for the channel A transmitter, which is the clock that shifts the transmitted data. If data is not being transmitted, a free running  $1 \times$  clock is output.

—The  $1 \times$  clock for the channel A receiver, which is the clock that samples the received data. If data is not being received, a free running  $1 \times$  clock is output.

**ACR — Auxiliary Control Register****ACR[7] — Baud Rate Generator Set Select**

This bit selects one of two sets of baud rates to be generated by the BRG:

Set 1: 50, 110, 134.5, 200, 300, 600, 1.05k, 1.2k, 2.4k, 4.8k, 7.2k, 9.6k, and 38.4k baud.

Set 2: 75, 110, 134.5, 150, 300, 600, 1.2k, 1.8k, 2.0k, 2.4k, 4.8k, 9.6k, and 19.2k baud.

The selected set of rates is available for use by the channel A and B receivers and transmitters as described in CSRA and CSRB. Baud rate generator characteristics are given in Table 3.

**ACR[6:4] — Counter/Timer Mode And Clock Source Select**

This field selects the operating mode of the counter/timer and its clock source as shown in Table 4.

**ACR[3:0] — IP3, IP2, IP1, IP0 Change Of State Interrupt Enable**

This field selects which bits of the input port change register (IPCR) cause the input change bit in the interrupt status register (ISR[7]) to be set. If a bit is in the 'on' state, the setting of the corresponding bit in the IPCR will also result in the setting of ISR[7], which results in the generation of an interrupt output if IMR[7] = 1. If a bit is in the 'off' state, the setting of that bit in the IPCR has no effect on ISR[7].

**IPCR — Input Port Change Register****IPCR[7:4] — IP3, IP2, IP1, IP0 Change-of-State**

These bits are set when a change-of-state, as defined in the input port section of this data sheet, occurs at the respective input pins. They are cleared when the IPCR is read by the CPU. A read of the IPCR also clears ISR[7], the input change bit in the interrupt status register.

The setting of these bits can be programmed to generate an interrupt to the CPU.

**IPCR[3:0] — IP3, IP2, IP1, IP0 Current State**

These bits provide the current state of the respective inputs. The information is unlatched and reflects the state of the input pins at the time the IPCR is read.

**ISR — Interrupt Status Register**

This register provides the status of all potential interrupt sources. The contents of this register are masked by the interrupt mask register (IMR). If a bit in the ISR is a '1' and the corresponding bit in the IMR is also a '1', the INTRN output will be asserted. If the corresponding bit in the IMR is a zero, the state of the bit in the ISR has no effect on the INTRN output. Note that the IMR does not mask the reading of the ISR — the true status will be provided regardless of the contents of

the IMR. The contents of this register are initialized to 00<sub>16</sub> when the DUART is reset.

**ISR[7] — Input Port Change Status**

This bit is a '1' when a change of state has occurred at the IP0, IP1, IP2, or IP3 inputs and that event has been selected to cause an interrupt by the programming of ACR[3:0]. The bit is cleared when the CPU reads the IPCR.

**ISR[6] — Channel B Change In Break**

This bit, when set, indicates that the channel B receiver has detected the beginning or the end of a received break. It is reset when the CPU issues a channel B 'reset break change interrupt' command.

**ISR[5] — Channel B Receiver Ready Or FIFO Full**

The function of this bit is programmed by MR1B[6]. If programmed as receiver ready, it indicates that a character has been received in channel B and is waiting in the FIFO to be read by the CPU. It is set when the character is transferred from the receive shift register to the FIFO and reset when the CPU reads the RHR. If after this read there are more characters still in the FIFO the bit will be set again after the FIFO is 'popped'. If programmed as FIFO full, it is set when a character is transferred from the receive holding register to the receive FIFO and the transfer causes the channel B FIFO to become full; i.e., all three FIFO positions are occupied. It is reset when the CPU reads the RHR. If a character is waiting in the receive shift register because the FIFO is full, the bit will be set again when the waiting character is loaded into the FIFO.

**ISR[4] — Channel B Transmitter Ready**

This bit is a duplicate of TxRDYB (SRB[2]).

**ISR[3] — Counter Ready**

In the counter mode, this bit is set when the counter reaches terminal count and is reset when the counter is stopped by a stop counter command.

In the timer mode, this bit is set once each cycle of the generated square wave (every other time that the counter/timer reaches zero count). The bit is reset by a stop counter command. The command, however, does not stop the counter/timer.

**ISR[2] — Channel A Change In Break**

This bit, when set, indicates that the channel A receiver has detected the beginning or the end of a received break. It is reset when the CPU issues a channel A 'reset break change interrupt' command.

**ISR[1] — Channel A Receiver Ready Or FIFO Full**

The function of this bit is programmed by MR1A[6]. If programmed as receiver ready, it indicates that a character has been received in channel A and is waiting in the FIFO to be

## Dual Asynchronous Receiver/Transmitter (DUART)

SCN2681

**Table 3. Baud Rate Generator Characteristics**  
Crystal or Clock = 3.6864MHz

NOMINAL RATE (BAUD)	ACTUAL $16 \times$ CLOCK (kHz)	ERROR (%)
50	0.8	0
75	1.2	0
110	1.759	-0.069
134.5	2.153	0.059
150	2.4	0
200	3.2	0
300	4.8	0
600	9.6	0
1050	16.756	-0.260
1200	19.2	0
1800	28.8	0
2000	32.056	0.175
2400	38.4	0
4800	76.8	0
7200	115.2	0
9600	153.6	0
19.2k	307.2	0
38.4k	614.4	0

**NOTE:**Duty cycle of  $16 \times$  clock is 50%  $\pm$ 1%**Table 4. ACR 6:4 Field Definition**

ACR 6:4	MODE	CLOCK SOURCE
0 0 0	Counter	External (IP2)
0 0 1	Counter	TxCA — $1 \times$ clock of channel A transmitter
0 1 0	Counter	TxCB — $1 \times$ clock of channel B transmitter
0 1 1	Counter	Crystal or external clock (X1/CLK) divided by 16
1 0 0	Timer	External (IP2)
1 0 1	Timer	External (IP2) divided by 16
1 1 0	Timer	Crystal or external clock (X1/CLK)
1 1 1	Timer	Crystal or external clock (X1/CLK) divided by 16

read by the CPU. It is set when the character is transferred from the receive shift register to the FIFO and reset when the CPU reads the RHR. If after this read there are more characters still in the FIFO the bit will be set again after the FIFO is 'popped'. If programmed as FIFO full, it is set when a character is transferred from the receive holding register to the receive FIFO and the transfer causes the channel A FIFO to become full, i.e., all three FIFO positions are occupied. It is reset when the CPU reads the RHR. If a character is waiting in the receive shift register because the FIFO is full, the bit will be set again when the waiting character is loaded into the FIFO.

**ISR[0] — Channel A Transmitter Ready**  
This bit is a duplicate of TxRDYA (SRA[2]).

**IMR — Interrupt Mask Register**

The programming of this register selects which bits in the ISR cause an interrupt

output. If a bit in the ISR is a '1' and the corresponding bit in the IMR is also a '1', the INTRN output will be asserted. If the corresponding bit in the IMR is a zero, the state of the bit in the ISR has no effect on the INTRN output. Note that the IMR does not mask the programmable interrupt outputs OP3–OP7 or the reading of the ISR.

**CTUR And CTLR — Counter/Timer Registers**

The CTUR and CTLR hold the eight MSBs and eight LSBs, respectively, of the value to be used by the counter/timer in either the counter or timer modes of operation. The minimum value which may be loaded into the CTUR/CTLR registers is  $0002_{16}$ . Note that these registers are write-only and cannot be read by the CPU.

In the timer (programmable divider) mode, the C/T generates a square wave with a period of

twice the value (in clock periods) of the CTUR and CTLR. If the value in CTUR or CTLR is changed, the current half-period will not be affected, but subsequent half periods will be. In this mode the C/T runs continuously. Receipt of a start counter command (read with A3–A0 = 1110) causes the counter to terminate the current timing cycle and to begin a new cycle using the values in CTUR and CTLR.

The counter ready status bit (ISR[3]) is set once each cycle of the square wave. The bit is reset by a stop counter command (read with A3–A0 = 1111). The command, however, does not stop the C/T. The generated square wave is output on OP3 if it is programmed to be the C/T output.

On power up and after reset, the timer/counter runs in timer mode and can only be restarted. Because it cannot be shut off or stopped, and runs continuously in timer mode, it is recommended that at initialization, the output port (OP3) should be masked off through the OPCR[3:2] = 00 until the T/C is programmed to the desired operational state.

In the counter mode, the C/T counts down the number of pulses loaded into CTUR and CTLR by the CPU. Counting begins upon receipt of a start counter command. Upon reaching terminal count ( $0000_{16}$ ), the counter ready interrupt bit (ISR[3]) is set. The counter continues counting past the terminal count until stopped by the CPU. If OP3 is programmed to be the output of the C/T, the output remains high until terminal count is reached, at which time it goes low. The output returns to the high state and ISR[3] is cleared when the counter is stopped by a stop counter command. The CPU may change the values of CTUR and CTLR at any time, but the new count becomes effective only on the next start counter command. If new values have not been loaded, the previous count values are preserved and used for the next count cycle.

In the counter mode, the current value of the upper and lower 8 bits of the counter (CTU, CTL) may be read by the CPU. It is recommended that the counter be stopped when reading to prevent potential problems which may occur if a carry from the lower 8 bits to the upper 8 bits occurs between the times that both halves of the counter are read. However, note that a subsequent start counter command will cause the counter to begin a new count cycle using the values in CTUR and CTLR.

## Dual Asynchronous Receiver/Transmitter (DUART)

SCN2681

ABSOLUTE MAXIMUM RATINGS<sup>1</sup>

SYMBOL	PARAMETER	RATING	UNIT
T <sub>A</sub>	Operating ambient temperature <sup>2</sup> range	0 to +70	°C
T <sub>STG</sub>	Storage temperature range	-65 to +150	°C
	All voltages with respect to ground <sup>3</sup>	-0.5 to +6.0	V

DC ELECTRICAL CHARACTERISTICS T<sub>A</sub> = 0°C to +70°C, V<sub>CC</sub> = +5V ± 5%<sup>4, 5, 6</sup>

SYMBOL	PARAMETER	TEST CONDITIONS	LIMITS			UNIT
			Min	Typ	Max	
V <sub>IL</sub>	Input low voltage				0.8	V
V <sub>IH</sub>	Input high voltage (except X1/CLK)		2			V
V <sub>IH</sub>	Input high voltage (X1/CLK)		4			V
V <sub>OL</sub>	Output low voltage	I <sub>OL</sub> = 2.4mA			0.4	V
V <sub>OH</sub>	Output high voltage (except o.c. outputs)	I <sub>OH</sub> = -400µA	2.4			V
I <sub>IL</sub>	Input leakage current	V <sub>IN</sub> = 0 to V <sub>CC</sub>	-10		10	µA
I <sub>LL</sub>	Data bus 3-State leakage current	V <sub>O</sub> = 0.4 to V <sub>CC</sub>	-10		10	µA
I <sub>X1L</sub>	X1/CLK low input current	V <sub>IN</sub> = 0, X2 grounded	-4	-2	0	mA
		V <sub>IN</sub> = 0, X2 floated	-3	-1.5	0	mA
I <sub>X1H</sub>	X1/CLK high input current	V <sub>IN</sub> = V <sub>CC</sub> , X2 grounded	-1	0.2	1	mA
		V <sub>IN</sub> = V <sub>CC</sub> , X2 floated	0	3.5	10	mA
I <sub>X2L</sub>	X2 low input current	V <sub>IN</sub> = 0, X1/CLK floated	-100	-30	0	µA
I <sub>X2H</sub>	X2 high input current	V <sub>IN</sub> = V <sub>CC</sub> , X1/CLK floated	0	+30	100	µA
I <sub>OC</sub>	Open-collector output leakage current	V <sub>O</sub> = 0.4 to V <sub>CC</sub>	-10		10	µA
I <sub>CC</sub>	Power supply current				150	mA

## NOTES:

- Stresses above those listed under Absolute Maximum Ratings may cause permanent damage to the device. This is a stress rating only and functional operation of the device at these or any other condition above those indicated in the operation section of this specification is not implied.
- For operating at elevated temperatures, the device must be derated based on +150°C maximum junction temperature.
- This product includes circuitry specifically designed for the protection of its internal devices from damaging effects of excessive static charge. Nonetheless, it is suggested that conventional precautions be taken to avoid applying any voltages larger than the rated maxima.
- Parameters are valid over specified temperature range.
- All voltage measurements are referenced to ground (GND). For testing, all inputs except X1/CLK swing between 0.4V and 2.4V with a transition time of 20ns maximum. For X1/CLK this swing is between 0.4V and 4.4V. All time measurements are referenced at input voltages of 0.8V and 2V as appropriate.
- Typical values are at +25°C, typical supply voltages, and typical processing parameters.
- Test condition for outputs: C<sub>L</sub> = 150pF, except interrupt outputs. Test condition for interrupt outputs: C<sub>L</sub> = 50pF, R<sub>L</sub> = 2.7kΩ to V<sub>CC</sub>.
- Timing is illustrated and referenced to the WRN and RDN inputs. The device may also be operated with CEN as the 'strobing' input. In this case, all timing specifications apply referenced to the falling and rising edges of CEN. CEN and RDN (also CEN and WRN) are AND'ed internally. As a consequence, the signal asserted last initiates the cycle and the signal negated first terminates the cycle.
- If CEN is used as the 'strobing' input, the parameter defines the minimum high times between one CEN and the next. The RDN signal must be negated for t<sub>RWD</sub> to guarantee that any status register changes are valid.
- Consecutive write operations to the same command register require at least three edges of the X1 clock between writes.

## Dual Asynchronous Receiver/Transmitter (DUART)

SCN2681

**AC ELECTRICAL CHARACTERISTICS**  $T_A = 0^\circ\text{C}$  to  $+70^\circ\text{C}$ ,  $V_{CC} = +5.0\text{V} \pm 5\%$ <sup>4, 5, 6, 7</sup>

SYMBOL	PARAMETER	LIMITS			UNIT
		Min	Typ	Max	
<b>Reset timing (Figure 1)</b>					
$t_{RES}$	RESET pulse width	1.0			$\mu\text{s}$
<b>Bus timing (Figure 2)<sup>8</sup></b>					
$t_{AS}$	A0 - A3 setup time to RDN, WRN low	10			ns
$t_{AH}$	A0 - A3 hold time from RDN, WRN high	0			ns
$t_{CS}$	CEN setup time to RDN, WRN low	0			ns
$t_{CH}$	CEN hold time from RDN, WRN high	0			ns
$t_{RW}$	WRN, RDN pulse width	225			ns
$t_{DD}$	Data valid after RDN low			175	ns
$t_{DF}$	Data bus floating after RDN high			100	ns
$t_{DS}$	Data setup time before WRN high	100			ns
$t_{DH}$	Data hold time after WRN high	20			ns
$t_{RWD}$	High time between READs and/or WRITEs <sup>9,10</sup>	200			ns
<b>Port timing (Figure 3)<sup>8</sup></b>					
$t_{PS}$	Port input setup time before RDN low	0			ns
$t_{PH}$	Port input hold time after RDN high	0			ns
$t_{PD}$	Port output valid after WRN high			400	ns
<b>Interrupt timing (Figure 4)</b>					
$t_{IR}$	INTRN (or OP3 - OP7 when used as interrupts) negated from: Read RHR (RxRDY/FFULL interrupt) Write THR (TxRDY interrupt) Reset command (delta break interrupt) Stop C/T command (counter interrupt) Read IPCR (input port change interrupt) Write IMR (clear of interrupt mask bit)			300 300 300 300 300 300	ns ns ns ns ns ns
<b>Clock timing (Figure 5)</b>					
$t_{CLK}$	X1/CLK high or low time	100			ns
$f_{CLK}$	X1/CLK frequency	2	3.6864	4	MHz
$t_{CTC}$	CTCLK (IP2) high or low time	100			ns
$f_{CTC}$	CTCLK (IP2) frequency	0		4	MHz
$t_{RX}$	RxC high or low time	220			ns
$f_{RX}$	RxC frequency (16 $\times$ ) (1 $\times$ )	0 0		2 1	MHz MHz
$t_{TX}$	TxC high or low time	220			ns
$f_{TX}$	TxC frequency (16 $\times$ ) (1 $\times$ )	0 0		2 1	MHz MHz
<b>Transmitter timing (Figure 6)</b>					
$t_{TXD}$	TxD output delay from TxC low			350	ns
$t_{TCS}$	Output delay from TxC low to TxD data output	0		150	ns
<b>Receiver timing (Figure 7)</b>					
$t_{RXS}$	RxD data setup time to RxC high	240			ns
$t_{RXH}$	RxD data hold time from RxC high	200			ns

2

# Dual Asynchronous Receiver/Transmitter (DUART)

SCN2681

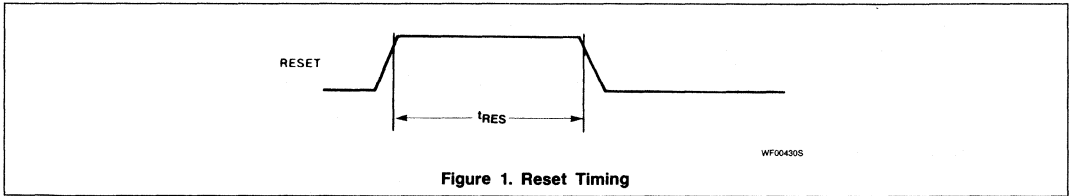

Figure 1. Reset Timing

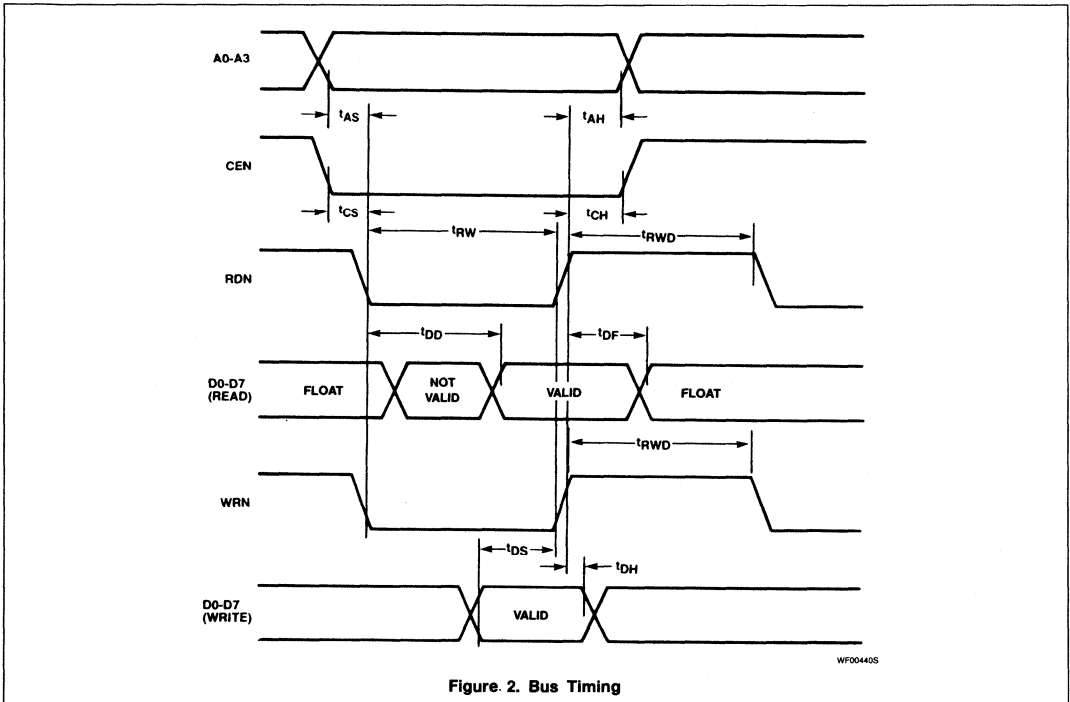

Figure 2. Bus Timing

# Dual Asynchronous Receiver/Transmitter (DUART)

SCN2681

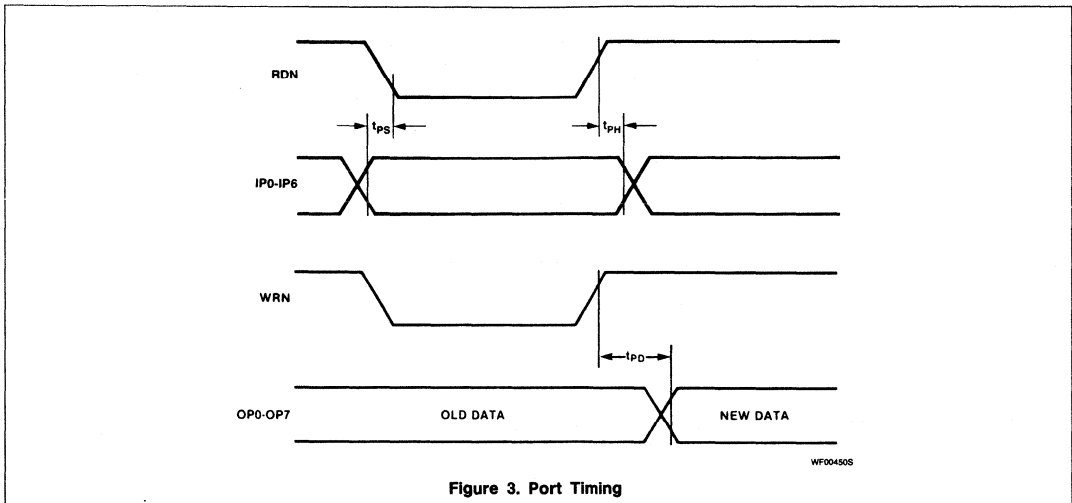
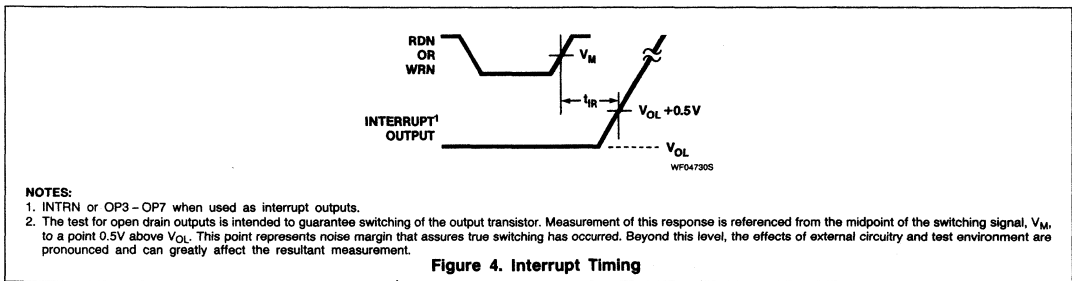

Figure 3. Port Timing



**NOTES:**

1. INTRN or OP3 - OP7 when used as interrupt outputs.
2. The test for open drain outputs is intended to guarantee switching of the output transistor. Measurement of this response is referenced from the midpoint of the switching signal,  $V_M$ , to a point 0.5V above  $V_{OL}$ . This point represents noise margin that assures true switching has occurred. Beyond this level, the effects of external circuitry and test environment are pronounced and can greatly affect the resultant measurement.

Figure 4. Interrupt Timing

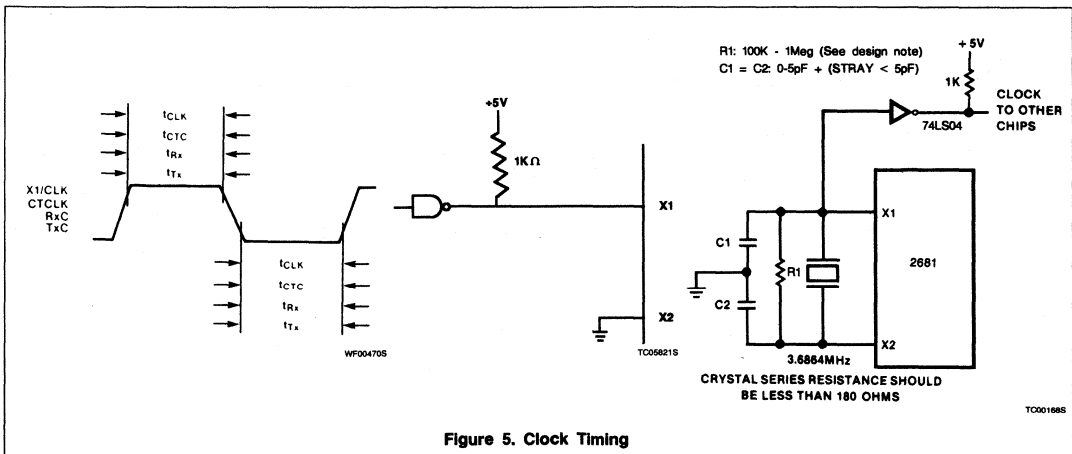

Figure 5. Clock Timing

# Dual Asynchronous Receiver/Transmitter (DUART)

SCN2681

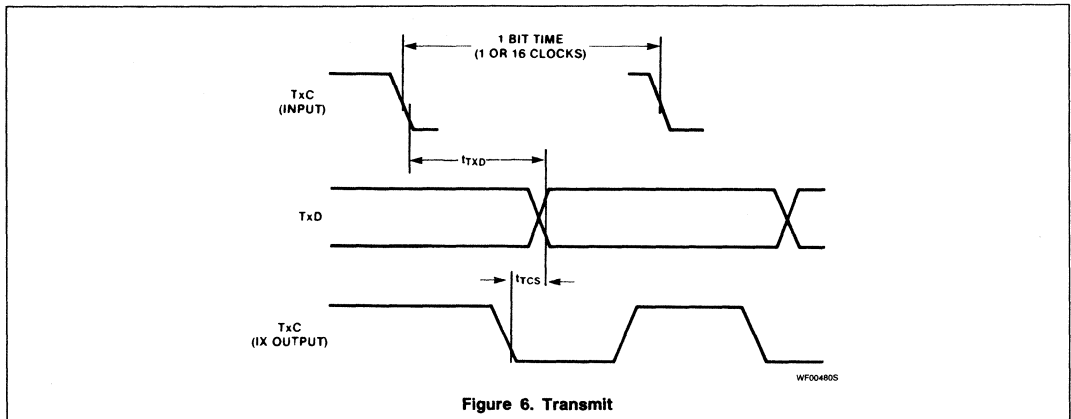

Figure 6. Transmit

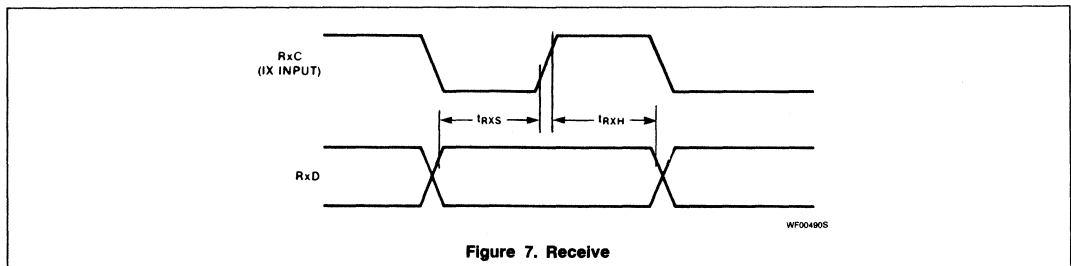
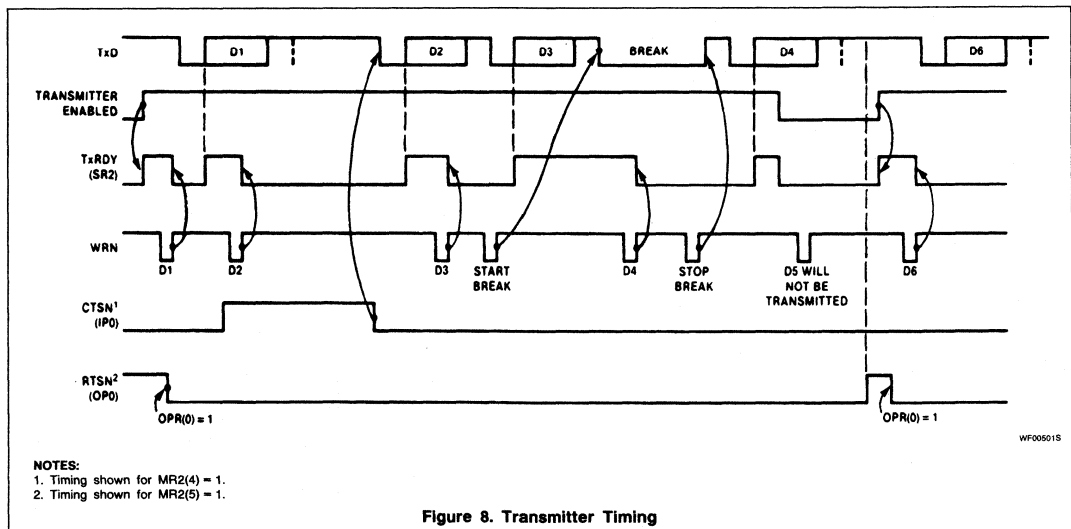

Figure 7. Receive



- NOTES:  
 1. Timing shown for MR2(4) = 1.  
 2. Timing shown for MR2(5) = 1.

Figure 8. Transmitter Timing



Dual Asynchronous Receiver/Transmitter (DUART)

SCN2681

2

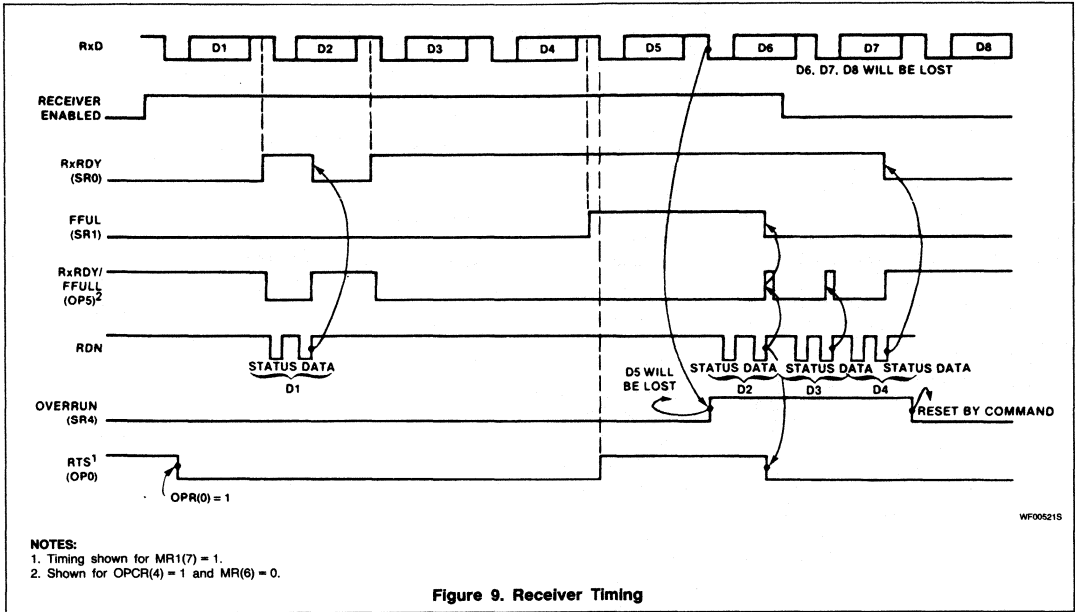

Figure 9. Receiver Timing

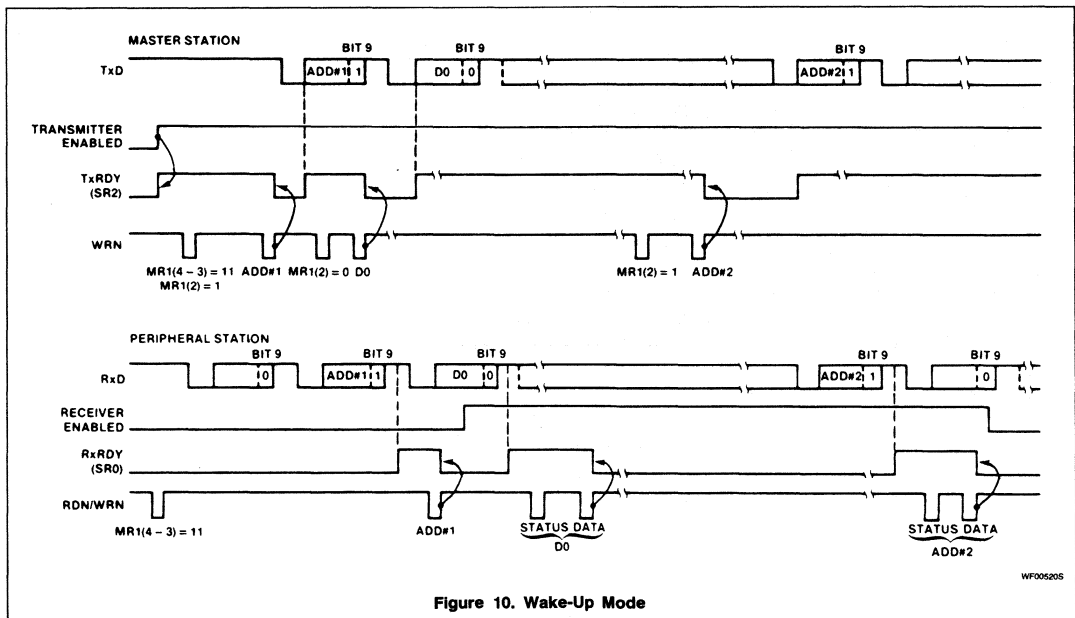

Figure 10. Wake-Up Mode

# SCC2691

## Universal Asynchronous Receiver/Transmitter (UART)

### Product Specification

#### Microprocessor Products

#### DESCRIPTION

The Signetics SCC2691 Universal Asynchronous Receiver/Transmitter (UART) is a single-chip CMOS-LSI communications device that provides a full-duplex asynchronous receiver/transmitter in a single 24-pin DIP. It is fabricated with Signetics CMOS technology which combines the benefits of high density and low power consumption.

The operating speed of the receiver and transmitter can be selected independently as one of eighteen fixed baud rates, a  $16\times$  clock derived from a programmable counter/timer, or an external  $1\times$  or  $16\times$  clock. The baud rate generator and counter/timer can operate directly from a crystal or from external clock inputs. The ability to independently program the operating speed of the receiver and transmitter make the UART particularly attractive for dual-speed channel applications such as clustered terminal systems.

The receiver is quadruple buffered to minimize the potential of receiver overrun or to reduce interrupt overhead in interrupt driven systems. In addition, a handshaking capability is provided to disable a remote UART transmitter when the receiver buffer is full.

The UART provides a power-down mode in which the oscillator is frozen but the register contents are stored. This results in reduced power consumption on the order of several magnitudes.

The UART is fully TTL compatible and operates from a single +5V power supply.

#### FEATURES

- Full-duplex asynchronous receiver/transmitter
- Quadruple buffered receiver data register
- Programmable data format:
  - 5 to 8 data bits plus parity
  - Odd, even, no parity or force parity
  - 1, 1.5 or 2 stop bits programmable in  $1/16$ -bit increments
- Baud rate for the receiver and transmitter selectable from:
  - 18 fixed rates: 50 to 38.4k baud
  - One user-defined rate derived from programmable timer/counter
  - External  $1\times$  or  $16\times$  clock
- Parity, framing, and overrun error detection
- False start bit detection
- Line break detection and generation
- Programmable channel mode
  - Normal (full-duplex)
  - Automatic echo
  - Local loopback
  - Remote loopback
- Multi-function programmable 16-bit counter/timer
- Single interrupt output with seven maskable interrupting conditions
- On-chip crystal oscillator
- Low power mode
- TTL compatible
- Single +5V power supply
- 300 MIL wide DIP

#### PIN CONFIGURATIONS

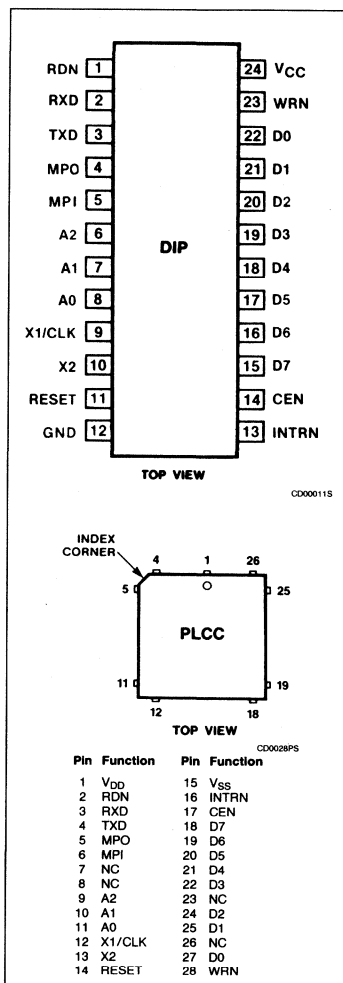

# Universal Asynchronous Receiver/Transmitter (UART)

SCC2691

**2**

## ORDERING INFORMATION

PACKAGES	$V_{CC} = +5V \pm 10\%$ , $T_A = 0^\circ C$ to $+70^\circ C$
Plastic DIP	SCC2691AC1N24
Plastic LCC	SCC2691AC1A28

## BLOCK DIAGRAM

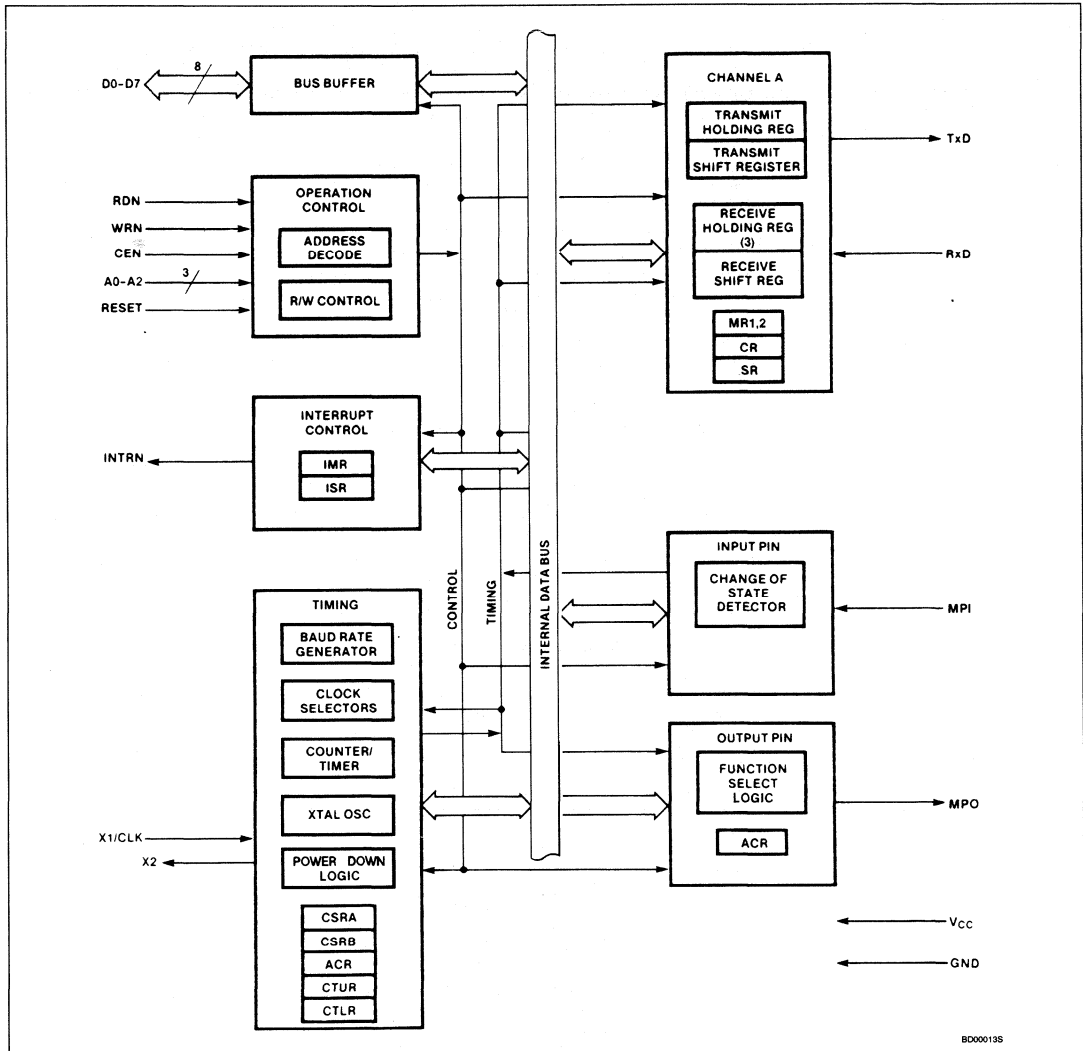

## Universal Asynchronous Receiver/Transmitter (UART)

SCC2691

## PIN DESCRIPTION

MNEMONIC	PIN NO.		TYPE	NAME AND FUNCTION
	DIP	PLCC		
D0 – D7	22 – 15	26 – 24 22 – 18	I/O	<b>Data Bus:</b> Active high 8-bit bidirectional 3-State data bus. Bit 0 is the LSB and bit 7 is the MSB. All data, command, and status transfers between the CPU and the UART take place over this bus. The direction of the transfer is controlled by the WRN and RDN inputs when the CEN input is low. When the CEN input is high, the data bus is in the 3-State condition.
CEN	14	17	I	<b>Chip Enable:</b> Active low input. When low, data transfers between the CPU and the UART are enabled on D0 – D7 as controlled by the WRN, RDN, and A0 – A2 inputs. When CEN is high, the UART is effectively isolated from the data bus and D0 – D7 are placed in the 3-State condition.
WRN	23	27	I	<b>Write Strobe:</b> Active low input. A low on this pin while CEN is low causes the contents of the data bus to be transferred to the register selected by A0 – A2. The transfer occurs on the trailing (rising) edge of the signal.
RDN	1	2	I	<b>Read Strobe:</b> Active low input. A low on this pin while CEN is low causes the contents of the register selected by A0 – A2 to be placed on the data bus. The read cycle begins on the leading (falling) edge of RDN.
A0 – A2	8 – 6	10 – 8	I	<b>Address Inputs:</b> Active high address inputs to select the UART registers for read/write operations.
RESET	11	13	I	<b>Reset:</b> Master reset. A high on this pin clears the status register (SR), clears the interrupt mask register (IMR), and places the receiver and transmitter in the inactive state causing the TxD output to go to the marking (high) state.
INTRN	13	16	O	<b>Interrupt Request:</b> This active low output is asserted upon occurrence of one or more of seven maskable interrupting conditions. The CPU can read the interrupt status register to determine the interrupting condition(s). This open-drain output requires a pull-up resistor.
X1/CLK	9	11	I	<b>Crystal 1:</b> Crystal or external clock input. When using the crystal oscillator, this pin serves as the connection for one side of the crystal. If a crystal is not used, an external clock is supplied at this input. An external clock (or crystal) is required even if the internal baud rate generator is not utilized. This clock is used to drive the internal baud rate generator, as an optional input to the timer/counter, and to provide other clocking signals required by the chip.
X2	10	12	O	<b>Crystal 2:</b> Connection for other side of crystal. If an external source is used instead of a crystal, this connection should be open.
RxD	2	3	I	<b>Receiver Serial Data Input:</b> The least significant bit is received first. If external receiver clock is specified, this input is sampled on the rising edge of the clock.
TxD	3	4	O	<b>Transmitter Serial Data Output:</b> The least significant bit is transmitted first. This output is held in the marking (high) condition when the transmitter is idle or disabled and when the UART is operating in local loopback mode. If external transmitter clock is specified, the data is shifted on the falling edge of the transmitter clock.
MPO	4	5	O	<b>Multi-Purpose Output:</b> One of the following functions can be selected for this output pin by programming the auxiliary control register: <b>RTSN</b> – Request to send active low output. This output is asserted and negated via the command register. By appropriate programming of the mode registers, RTSN can be programmed to be automatically reset after the character in the transmitter is completely shifted or when the receiver FIFO and shift register are full. <b>C/TO</b> — The counter/timer output. <b>TxC1X</b> — The 1X clock for the transmitter. <b>TxC16X</b> — The 16X clock for the transmitter. <b>RxC1X</b> — The 1X clock for the receiver. <b>RxC16X</b> — The 16X clock for the receiver. <b>TxRDY</b> — The transmitter holding register empty signal. Active low interrupt. <b>RxDY/FFULL</b> — The receiver FIFO not empty/full signal. Active low interrupt.
MPI	5	6	I	<b>Multi-Purpose Input:</b> This pin can be programmed to serve as an input for one of the following functions: <b>GPI</b> — General purpose input. The current state of the pin can be determined by reading the ISR. <b>CTSN</b> — Clear-to-Send active low input. <b>CTCLK</b> — Counter/timer external clock input. <b>RTCLK</b> — Receiver and/or transmitter external clock input. This may be a 1X or 16X clock as programmed by CSR[3:0] or CSR[7:4].
V <sub>CC</sub>	24	28	I	<b>Power Supply:</b> +5V supply input.
GND	12	14	I	<b>Ground</b>

## Universal Asynchronous Receiver/Transmitter (UART)

SCC2691

**BLOCK DIAGRAM**

As shown on the block diagram, the UART consists of: data bus buffer, interrupt control, operation control, timing, receiver and transmitter.

**Data Bus Buffer**

The data bus buffer provides the interface between the external and internal data buses. It is controlled by the operation control block to allow read and write operations to take place between the controlling CPU and the UART.

**Interrupt Control**

A single interrupt output (INTRN) is provided which is asserted upon the occurrence of any of the following internal events:

- Transmit holding register ready
- Transmit shift register empty
- Receive holding register ready or FIFO full
- Change in break received status
- Counter reached terminal count
- Change in MPI input

Associated with the interrupt system are the interrupt mask register (IMR) and the interrupt status register (ISR). The IMR can be programmed to select only certain of the above conditions to cause INTRN to be asserted. The ISR can be read by the CPU to determine all currently active interrupting conditions. However, the bits of the ISR are not masked by the IMR.

**Operation Control**

The operation control logic receives operation commands from the CPU and generates appropriate signals to internal sections to control device operation. It contains address decoding and read and write circuits to permit communications with the microprocessor via the data bus buffer. The functions performed by the CPU read and write operations are shown in Table 1.

**Table 1. Register Addressing**

A2	A1	A0	READ (RDN=0)	WRITE (WRN=0)
0	0	0	MR1,MR2	MR1, MR2
0	0	1	SR	CSR
0	1	0	Reserved*	CR
0	1	1	RHR	THR
1	0	0	Reserved*	ACR
1	0	1	ISR	IMR
1	1	0	CTU	CTUR
1	1	1	(CTL)	CTLR

**NOTE:**

\*Reserved registers should never be read during normal operation since they are reserved for internal diagnostics.

ACR = Auxiliary control register  
 CR = Command register  
 CSR = Clock select register  
 CTL = Counter/timer lower  
 CTLR = Counter/timer lower register  
 CTU = Counter/timer upper  
 CTUR = Counter/timer upper register  
 MR = Mode register A  
 SR = Status register  
 THR = Tx holding register

Mode registers 1 and 2 are accessed via an auxiliary pointer. The pointer is set to MR1 by RESET or by issuing a reset pointer command via the command register. Any read or write of the mode register while the pointer is at MR1 switches the pointer to MR2. The pointer then remains at MR2 so that subsequent accesses are to MR2, unless the pointer is reset to MR1 as described above.

**Timing Circuits**

The timing block consists of a crystal oscillator, a baud rate generator, a programmable 16-bit counter/timer, and two clock selectors.

The crystal oscillator operates directly from a 3.6864MHz crystal connected across the X1/CLK and X2 inputs with a minimum of external components. If an external clock of the appropriate frequency is available, it may be connected to X1/CLK. If an external clock is used instead of a crystal, X1/CLK is driven using a configuration similar to the one in Figure 5. However, the input high voltage must be capable of attaining 4.4V. The clock serves as the basic timing reference for the baud rate generator (BRG), the counter/timer, and other internal circuits. A clock frequency, within the limits specified in the electrical specifications, must be supplied even if the internal BRG is not used.

The baud rate generator operates from the oscillator or external clock input and is capable of generating 18 commonly used data communications baud rates ranging from 50 to 38.4K baud. Thirteen of these are available simultaneously for use by the receiver and transmitter. Eight are fixed, and one of two sets of five can be selected by programming ACR[7]. The clock outputs from the BRG are at  $16\times$  the actual baud rate. The counter/timer can be used as a timer to produce a  $16\times$  clock for any other baud rate by counting down the crystal clock or an external clock. The clock selectors allow the independent selection by the receiver and transmitter of any of these baud rates or an external timing signal.

The C/T operation is programmed by ACR[6:4]. One of eight timing sources can be used as the input to the C/T. The output of the C/T is available to the clock selectors and can also be programmed by ACR[2:0], to be output on the MPO pin.

In the timer mode, the C/T generates a square wave whose period is twice the number of clock periods loaded into the C/T upper and lower registers. The counter ready bit in the ISR is set once each cycle of the square wave. If the value in CTUR or CTLR is changed, the current half-period will not be affected, but subsequent half-periods will be affected. In this mode the C/T runs continuously and does not recognize the stop counter command (the command only resets the counter ready bit in the ISR). Receipt of a start C/T command causes the counter to terminate the current timing cycle and to begin a new cycle using the values in CTUR and CTLR.

In the counter mode, the C/T counts down the number of pulses loaded into CTUR and CTLR. Counting begins upon receipt of a start C/T command. Upon reaching terminal count, the counter ready bit in the ISR is set. The counter continues counting past the terminal count until stopped by the CPU. If MPO is programmed to be the output of the C/T, the output remains high until terminal count is reached, at which time it goes low. The output returns to the high state and the counter ready bit is cleared when the counter is stopped by a stop counter command. The CPU may change the values of CTUR and CTLR at any time, but the new count becomes effective only on the next start counter command following a stop counter command. If new values have not been loaded, the previous count values are preserved and used for the next count cycle.

In the counter mode, the current value of the upper and lower 8 bits of the counter may be read by the CPU. It is recommended that the counter be stopped when reading to prevent potential problems which may occur if a carry from the lower 8 bits to the upper 8 bits occurs between the times that both halves of the counter are read. However a subsequent start counter command causes the counter to begin a new count cycle using the values in CTUR and CTLR.

**Receiver and Transmitter**

The UART is a full-duplex asynchronous receiver/transmitter. The operating frequency for the receiver and transmitter can be selected independently from the baud rate generator, the counter/timer, or from an external input. Registers associated with the communications channel are the mode registers (MR1 and MR2), the clock select register (CSR), the command register (CR), the status register (SR), the transmit holding register (THR), and the receive holding register (RHR).

**Transmitter**

The transmitter accepts parallel data from the CPU and converts it to a serial bit stream on

# Universal Asynchronous Receiver/Transmitter (UART)

## SCC2691

the TxD output pin. It automatically sends a start bit followed by the programmed number of data bits, an optional parity bit, and the programmed number of stop bits. The least significant bit is sent first. Following the transmission of the stop bits, if a new character is not available in the THR, the TxD output remains high and the TxEMT bit in the SR will be set to 1. Transmission resumes and the TxEMT bit is cleared when the CPU loads a new character into the THR. In the  $16\times$  clock mode, this also resynchronizes the internal  $1\times$  transmitter clock so that transmission of the new character begins with minimum delay.

The transmitter can be forced to send a break (continuous low condition) by issuing a start break command via the CR. The break is terminated by a stop break command.

If the transmitter is disabled, it continues operating until the character currently being transmitted and the character in the THR, if any, are completely sent out. Characters cannot be loaded into the THR while the transmitter is disabled.

### Receiver

The receiver accepts serial data on the RxD pin, converts the serial input to parallel format, checks for start bit, stop bit, parity bit (if any), or break condition, and presents the assembled character to the CPU. The receiver looks for a high-to-low (mark-to-space) transition of the start bit on the RxD input pin. If a transition is detected, the state of the RxD pin is sampled again each  $16\times$  clock for  $7\frac{1}{2}$  clocks ( $16\times$  clock mode) or at the next rising edge of the bit time clock ( $1\times$  clock mode). If RxD is sampled high, the start bit is invalid and the search for a valid start bit begins again. If RxD is still low, a valid start bit is assumed and the receiver continues to sample the input at one bit time intervals at the theoretical center of the bit, until the proper number of data bits and the parity bit (if any) have been assembled, and one stop bit has been detected. The least significant bit is received first. The data is then transferred to the RHR and the RxRDY bit in the SR is set to a 1. If the character length is less than eight bits, the most significant unused bits in the RHR are set to zero.

After the stop bit is detected, the receiver will immediately look for the next start bit. However, if a non-zero character was received without a stop bit (i.e. framing error) and RxD remains low for one-half of the bit period after the stop bit was sampled, then the receiver operates as if a new start bit transition had been detected at that point (one-half bit time after the stop bit was sampled). The parity error, framing error and overrun error (if any) are strobed into the SR at the received

character boundary, before the RxRDY status bit is set.

If a break condition is detected (RxD is low for the entire character including the stop bit) only one character consisting of all zeros will be loaded into the FIFO and the received break bit in the SR is set to 1. The RxD input must return to a high condition for two successive clock edges of the  $1\times$  clock (internal or external) before a search for the next start bit begins.

### RECEIVER FIFO

The RHR consists of a first-in-first-out (FIFO) queue with a capacity of three characters. Data is loaded from the receive shift register into the top-most empty position of the FIFO. The RxRDY bit in the status register (SR) is set whenever one or more characters are available to be read, and a FFULL status bit is set if all three queue positions are filled with data. Either of these bits can be selected to cause an interrupt. A read of the RHR outputs the data at the top of the FIFO. After the read cycle, the data FIFO and its associated status bits are 'popped' thus emptying a FIFO position for new data.

In addition to the data word, three status bits (parity error, framing error, and received break) are appended to each data character in the FIFO. Status can be provided in two ways, as programmed by the error mode control bit in the mode register. In the character mode, status is provided on a character-by-character basis: the status applies only to the character at the top of the FIFO. In the block mode, the status provided in the SR for these three bits is the logical-OR of the status for all characters coming to the top of the FIFO since the last reset error command was issued. In either mode, reading the SR does not affect the FIFO. The FIFO is 'popped' only when the RHR is read. Therefore, the SR should be read prior to reading the corresponding data character.

If the FIFO is full when a new character is received, that character is held in the receive shift register until a FIFO position is available. If an additional character is received while this state exists, the contents of the FIFO are not affected: the character previously in the shift register is lost and the overrun error status bit (SR[4]) will be set upon receipt of the start bit of the new (overrunning) character.

### WAKE-UP MODE

In addition to the normal transmitter and receiver operation described above, the UART incorporates a special mode which provides automatic wake-up of the receiver through address frame recognition for multi-

processor communications. This mode is selected by programming bits MR1[4:3] to '11'.

In this mode of operation, a 'master' station transmits an address character followed by data characters for the addressed 'slave' station. The slave stations, whose receivers are normally disabled, examine the received data stream and 'wake-up' the CPU (by setting RxRDY) only upon receipt of an address character. The CPU compares the received address to its station address and enables the receiver if it wishes to receive the subsequent data characters. Upon receipt of another address character, the CPU may disable the receiver to initiate the process again.

A transmitted character consists of a start bit, the programmed number of data bits, an address/data (A/D) bit, and the programmed number of stop bits. The polarity of the transmitted A/D bit is selected by the CPU by programming bit MR1[2]: MR1[2] = 0 transmits a zero in the A/D bit position which identifies the corresponding data bits as data, while MR1[2] = 1 transmits a one in the A/D bit position which identifies the corresponding data bits as an address. The CPU should program the mode register prior to loading the corresponding data bits into the THR.

While in this mode, the receiver continuously looks at the received data stream, whether it is enabled or disabled. If disabled, it sets the RxRDY status bit and loads the character into the RHR FIFO if the received A/D bit is a one, but discards the received character if the received A/D bit is a zero. If enabled, all received characters are transferred to the CPU via the RHR. In either case, the data bits are loaded into the data FIFO while the A/D bit is loaded into the status FIFO position normally used for parity error (SR[5]). Framing error, overrun error, and break detect operate normally whether or not the receiver is enabled.

### MULTI-PURPOSE INPUT PIN

The MPI pin can be programmed as an input to one of several UART circuits. The function of the pin is selected by programming the appropriate control register (MR2[4], ACR[6:4], CSR[7:4, 3:0]). Only one of the functions may be selected at any given time. If CTS or GPI is selected, a change of state detector provided with the pin is activated. A high-to-low or low-to-high transition of the inputs lasting longer than  $25 - 50\mu\text{s}$  sets the MPI change-of-state bit in the interrupt status register. The bit is cleared via a command. The change-of-state can be programmed to generate an interrupt to the CPU by setting the corresponding bit in the interrupt mask register.

# Universal Asynchronous Receiver/Transmitter (UART)

SCC2691

2

The input port pulse detection circuitry uses a 38.4kHz sampling clock derived from one of the baud rate generator taps. This produces a sampling period of slightly more than 25 $\mu$ s (assuming a 3.6864MHz oscillator input). The detection circuitry, in order to guarantee that a true change in level has occurred, requires two successive samples at the new logic level be observed. As a consequence, the minimum duration of the signal change is 25 $\mu$ s if the transition occurs coincident with the first sample pulse. The 50 $\mu$ s time refers to the condition where the change of state is just missed and the first change of state is not detected until after an additional 25 $\mu$ s.

## MULTI-PURPOSE OUTPUT PIN

This pin can be programmed to serve as a request-to-send output, the counter/timer output, the output for the 1 $\times$  or 16 $\times$  transmitter or receiver clocks, the TxRDY output or the RxRDY/FFULL output (see ACR [2:0] — MPO Output Select).

## REGISTERS

The operation of the UART is programmed by writing control words into the appropriate registers. Operational feedback is provided via status registers which can be read by the CPU. Addressing of the registers is as described in Table 1.

The contents of certain control registers are initialized to zero on RESET (see Reset pin description). Care should be exercised if the contents of a register are changed during operation, since certain changes may cause operational problems — e.g., changing the number of bits per character while the transmitter is active may cause the transmission of an incorrect character. The contents of the MR, the CSR, and the ACR should only be changed while the receiver(s) and transmitter(s) are disabled, and certain changes to the ACR should only be made while the C/T is stopped.

The bit formats of the UART registers are depicted in Table 2.

### MR1 — Mode Register 1

MR1 is accessed when the MR pointer points to MR1. The pointer is set to MR1 by RESET or by a set pointer command applied via CR. After reading or writing MR1, the pointers are set at MR2.

#### MR1[7] — Receiver Request-to-Send Control

This bit controls the deactivation of the RTSN output (MPO) by the receiver. This output is manually asserted and negated by commands applied via the command register. MR1[7] = 1 causes RTSN to be automatically negated upon receipt of a valid start bit if the

receiver FIFO is full. RTSN is reasserted when an empty FIFO position is available. This feature can be used to prevent overrun in the receiver by using the RTSN output signal to control the CTS input of the transmitting device.

#### MR1[6] — Receiver Interrupt Select

This bit selects either the receiver ready status (RxRDY) or the FIFO full status (FFULL) to be used for CPU interrupts.

#### MR1[5] — Error Mode Select

This bit selects the operating mode of the three FIFOed status bits (FE, PE, received break). In the character mode, status is provided on a character-by-character basis: the status applies only to the character at the top of the FIFO. In the block mode, the status provided in the SR for these bits is the accumulation (logical-OR) of the status for all characters coming to the top of the FIFO since the last reset error command was issued.

#### MR1[4:3] — Parity Mode Select

If with parity or force parity is selected, a parity bit is added to the transmitted character and the receiver performs a parity check on incoming data. MR1[4:3] = 11 selects the channel to operate in the special wake-up mode.

#### MR1[2] — Parity Type Select

This bit selects the parity type (odd or even) if the with parity mode is programmed by MR1[4:3], and the polarity of the forced parity bit if the force parity mode is programmed. It has no effect if the no parity mode is programmed. In the special wake up mode, it selects the polarity of the A/D bit.

#### MR1[1:0] — Bits per Character Select

This field selects the number of data bits per character to be transmitted and received. The character length does not include the start, parity, and stop bits.

### MR2 — Mode Register 2

MR2 is accessed when the channel MR pointer points to MR2, which occurs after any access to MR1. Accesses to MR2 do not change the pointer.

#### MR2[7:6] — Mode Select

The UART can operate in one of four modes: MR2[7:6] = 00 is the normal mode, with the transmitter and receiver operating independently. MR2[7:6] = 01 places the channel in the automatic echo mode, which automatically retransmits the received data. The following conditions are true while in automatic echo mode:

1. Received data is relocked and retransmitted on the TxD output.
2. The receive clock is used for the transmitter.

3. The receiver must be enabled, but the transmitter need not be enabled.
4. The TxRDY and TxEMT status bits are inactive.
5. The received parity is checked, but is not regenerated for transmission, i.e., transmitted parity bit is as received.
6. Character framing is checked, but the stop bits are retransmitted as received.
7. A received break is echoed as received until the next valid start bit is detected.
8. CPU-to-receiver communication continues normally, but the CPU-to-transmitter link is disabled.

Two diagnostic modes can also be selected. MR2[7:6] = 10 selects local loopback mode. In this mode:

1. The transmitter output is internally connected to the receiver input.
2. The transmit clock is used for the receiver.
3. The TxD output is held high.
4. The FxD input is ignored.
5. The transmitter must be enabled, but the receiver need not be enabled.
6. CPU to transmitter and receiver communications continue normally.

The second diagnostic mode is the remote loopback mode, selected by MR2[7:6] = 11. In this mode:

1. Received data is relocked and retransmitted on the TxD output.
2. The receive clock is used for the transmitter.
3. Received data is not sent to the local CPU, and the error status conditions are inactive.
4. The received parity is not checked and is not regenerated for transmission, i.e., the transmitted parity bit is as received.
5. The receiver must be enabled, but the transmitter need not be enabled.
6. Character framing is not checked, and the stop bits are retransmitted as received.
7. A received break is echoed as received until the next valid start bit is detected.

When switching in and out of the various modes, the selected mode is activated immediately upon mode selection, even if this occurs in the middle of a received or transmitted character. Likewise, if a mode is deselected, the device will switch out of the mode immediately. An exception to this is switching out of auto echo or remote loopback modes; if the deselection occurs just after the receiver has sampled the stop bit (indicated to be in autoecho by assertion of RxRDY), and the transmitter is enabled, the transmitter will

## Universal Asynchronous Receiver/Transmitter (UART)

SCC2691

remain in auto echo mode until one full stop bit has been retransmitted.

**MR2[5] — Transmitter Request-to-Send Control**

This bit controls the deactivation of the RTSN output (MPO) by the transmitter. This output is manually asserted and negated by appropriate commands issued via the command register. MR2[5] = 1 causes RTSN to be reset automatically one bit time after the characters in the transmit shift register and in the THR (if any) are completely transmitted; includes the programmed number of stop bits if the transmitter is not enabled. This feature can be used to automatically terminate the transmission of a message as follows:

1. Program auto-reset mode: MR2[5] = 1.
2. Enable transmitter.
3. Assert RTSN via command.
4. Send message.
5. Verify the next to last character of the message is being sent by waiting until

transmitter ready is asserted. Disable transmitter after the last character is loaded into the THR.

6. The last character will be transmitted and RTSN will be reset one bit time after the last stop bit.

**MR2[4] — Clear-to-Send Control**

The state of this bit determines if the CTSN input (MPI) controls the operation of the transmitter. If this bit is 0, CTSN has no effect on the transmitter. If this bit is a 1, the transmitter checks the state of CTSN each time it is ready to send a character. If it is asserted (low), the character is transmitted. If it is negated (high), the TxD output remains in the marking state and the transmission is delayed until CTSN goes low. Changes in CTSN while a character is being transmitted do not affect the transmission of that character. This feature can be used to prevent overrun of a remote receiver.

**MR2[3:0] — Stop Bit Length Select**

This field programs the length of the stop bit appended to the transmitted character. Stop bit lengths of  $9/16$  to 1 and  $19/16$  to 2 bits, in increments of  $1/16$  bit, can be programmed for character lengths of 6, 7, and 8 bits. For a character length of 5 bits,  $19/16$  to 2 stop bits can be programmed in increments of  $1/16$  bit. In all cases, the receiver only checks for a mark condition at the center of the first stop bit position (one bit time after the last data bit, or after the parity bit if parity is enabled). If an external  $1 \times$  clock is used for the transmitter, MR2[3] = 0 selects one stop bit and MR2[3] = 1 selects two stop bits to be transmitted.

**CSR — Clock Select Register****CSR[7:4] — Receiver Clock Select**

When using a 3.6864MHz crystal or external clock input, this field selects the baud rate clock for the receiver as shown in Table 3.

Table 2. Register Bit Formats

	BIT 7	BIT 6	BIT 5	BIT 4	BIT 3	BIT 2	BIT 1	BIT 0
	<b>RxRTS CONTROL</b>	<b>RxINT SELECT</b>	<b>ERROR MODE</b>	<b>PARITY MODE</b>		<b>PARITY TYPE</b>	<b>BITS PER CHAR</b>	
MR1	0=no 1=yes	0=RXRDY 1=FFULL	0=char 1=block	00=with parity 01=force parity 10=no parity 11=special mode		0=even 1=odd	00=5 01=6 10=7 11=8	

	BIT 7	BIT 6	BIT 5	BIT 4	BIT 3	BIT 2	BIT 1	BIT 0
	<b>CHANNEL MODE</b>		<b>TxRTS CONTROL</b>	<b>CTS ENABLE Tx</b>	<b>STOP BIT LENGTH*</b>			
MR2	00=Normal 01=Auto echo 10=Local loop 11=Remote loop		0=no 1=yes	0=no 1=yes	0=0.563 1=0.625 2=0.688 3=0.750	4=0.813 5=0.875 6=0.938 7=1.000	8=1.563 9=1.625 A=1.688 B=1.750	C=1.813 D=1.875 E=1.938 F=2.000

**NOTE:**

\*Add 0.5 to values shown for 0–7, if channel is programmed for 5 bits/char.

	BIT 7	BIT 6	BIT 5	BIT 4	BIT 3	BIT 2	BIT 1	BIT 0
	<b>RECEIVER CLOCK SELECT</b>				<b>TRANSMITTER CLOCK SELECT</b>			
CSR	See Text				See Text			

	BIT 7	BIT 6	BIT 5	BIT 4	BIT 3	BIT 2	BIT 1	BIT 0
	<b>MISCELLANEOUS COMMANDS</b>				<b>DISABLE Tx</b>	<b>ENABLE Tx</b>	<b>DISABLE Rx</b>	<b>ENABLE Rx</b>
CR	See Text				0=no 1=yes	0=no 1=yes	0=no 1=yes	0=no 1=yes



## Universal Asynchronous Receiver/Transmitter (UART)

SCC2691

Table 2. Register Bit Formats (Continued)

	BIT 7	BIT 6	BIT 5	BIT 4	BIT 3	BIT 2	BIT 1	BIT 0
SR	RECEIVED BREAK	FRAMING ERROR	PARITY ERROR	OVERRUN ERROR	TxE <sub>MT</sub>	TxRDY	FFULL	RxRDY
	0=no 1=yes *	0=no 1=yes *	0=no 1=yes *	0=no 1=yes	0=no 1=yes	0=no 1=yes	0=no 1=yes	0=no 1=yes

**NOTE:**

\*These status bits are appended to the corresponding data character in the receive FIFO. A read of the status register provides these bits [7:5] from the top of the FIFO together with bits [4:0]. These bits are cleared by a reset error status command. In character mode they are reset when the corresponding data character is read from the FIFO.

	BIT 7	BIT 6	BIT 5	BIT 4	BIT 3	BIT 2	BIT 1	BIT 0
ACR	BRG SET SELECT	COUNTER/TIMER MODE AND SOURCE			POWER- DOWN MODE	MPO PIN FUNCTION SELECT		
	0=set1 1=set2	See Text			0 = on 1 = off	000=RTSN 001=C/TO 010=TxC (1×) 011=TxC (16×)	100=RxC (1×) 101=RxC (16×) 110=TxRDY 111=RxRDY/FFULL	

	BIT 7	BIT 6	BIT 5	BIT 4	BIT 3	BIT 2	BIT 1	BIT 0
ISR	MPI PIN CHANGE	MPI PIN CURRENT STATE		COUNTER READY	DELTA BREAK	RxRDY/ FFULL	TxE <sub>MT</sub>	TxRDY
	0=no 1=yes	0=low 1=high	not used	0=no 1=yes	0=no 1=yes	0=no 1=yes	0=no 1=yes	0=no 1=yes

	BIT 7	BIT 6	BIT 5	BIT 4	BIT 3	BIT 2	BIT 1	BIT 0
IMR	MPI CHANGE INT	MPI LEVEL INT		COUNTER READY INT	DELTA BREAK INT	RxRDY/ FFULL INT	TxE <sub>MT</sub> INT	TxRDY INT
	0=off 1=on	0=off 1=on	not used	0=off 1=on	0=off 1=on	0=off 1=on	0=off 1=on	0=off 1=on

	BIT 7	BIT 6	BIT 5	BIT 4	BIT 3	BIT 2	BIT 1	BIT 0
CTUR	C/T[15]	C/T[14]	C/T[13]	C/T[12]	C/T[11]	C/T[10]	C/T[9]	C/T[8]

	BIT 7	BIT 6	BIT 5	BIT 4	BIT 3	BIT 2	BIT 1	BIT 0
CTLR	C/T[7]	C/T[6]	C/T[5]	C/T[4]	C/T[3]	C/T[2]	C/T[1]	C/T[0]

## Universal Asynchronous Receiver/Transmitter (UART)

SCC2691

Table 3. Baud Rate

CSR[3:0]/ [7:4]	ACR[7]=0	ACR[7]=1
0 0 0 0	50	75
0 0 0 1	110	110
0 0 1 0	134.5	134.5
0 0 1 1	200	150
0 1 0 0	300	300
0 1 0 1	600	600
0 1 1 0	1,200	1,200
0 1 1 1	1,050	2,000
1 0 0 0	2,400	2,400
1 0 0 1	4,800	4,800
1 0 1 0	7,200	1,800
1 0 1 1	9,600	9,600
1 1 0 0	38.4k	19.2k
1 1 0 1	Timer	Timer
1 1 1 0	MPI — 16×	MPI — 16×
1 1 1 1	MPI — 1×	MPI — 1×

The receiver clock is always a 16× clock, except for CSR[7:4]=1111.

**CSR[3:0] — Transmitter Clock Select**

This field selects the baud rate clock for the transmitter. The field definition is as shown in Table 3.

**CR — Command Register**

CR is used to write commands to the UART. Multiple commands can be specified in a single write to CR as long as the commands are non-conflicting, e.g., the enable transmitter and reset transmitter commands cannot be specified in a single command word.

**CR[7:4] — Miscellaneous Commands**

The encoded value of this field may be used to specify a single command as follows:

- 0000 No command.
- 0001 Reset MR pointer. Causes the MR pointer to point to MR1.
- 0010 Reset receiver. Resets the receiver as if a hardware reset had been applied. The receiver is disabled and the FIFO is flushed.
- 0011 Reset transmitter. Resets the transmitter as if a hardware reset had been applied.
- 0100 Reset error status. Clears the received break, parity error, framing error, and overrun error bits in the status register (SR[7:4]). Used in character mode to clear OE status (although RB, PE, and FE bits will also be cleared), and in block mode to clear all error status after a block of data has been received.
- 0101 Reset break change interrupt. Causes the break detect change bit in the interrupt status register (ISR[3]) to be cleared to zero.

- 0110 Start break. Forces the TxD output low (spacing). If the transmitter is empty, the start of the break condition will be delayed up to two bit times. If the transmitter is active, the break begins when transmission of the character is completed. If a character is in the THR, the start of break is delayed until that character or any others loaded after it has been transmitted (TxEMT must be true before break begins). The transmitter must be enabled to start a break.

- 0111 Stop break. The TxD line will go high (marking) within two bit times. TxD will remain high for one bit time before the next character, if any, is transmitted.

- 1000 Start C/T. In counter or timer modes, causes the contents of CTUR/ CTLR to be preset into the counter/timer and starts the counting cycle. In timer mode, any counting cycle in progress when the command is issued is terminated. In counter mode, has no effect unless a stop C/T command was issued previously.

- 1001 Stop counter. In counter mode, stops operation of the counter/timer, resets the counter ready bit in the ISR, and forces the MPO output high if it is programmed to be the output of the C/T. In timer mode, resets the counter ready bit in the ISR but has no effect on the counter/timer itself or on the MPO output.

- 1010 Assert RTSN. Causes the RTSN output to be asserted (low).

- 1011 Negate RTSN. Causes the RTSN output to be negated (high).

- 1100 Reset MPI change interrupt. Causes the MPI change bit in the interrupt status register (ISR[7]) to be cleared to zero.

- 1101 Reserved.

- 111x Reserved.

**CR[3] — Disable Transmitter**

This command terminates transmitter operation and resets the TxRDY and TxEMT status bits. However, if a character is being transmitted or if a character is in the THR when the transmitter is disabled, the transmission of the character(s) is completed before assuming the inactive state.

**CR[2] — Enable Transmitter**

Enables operation of the channel A transmitter. The TxRDY status bit will be asserted.

**CR[1] — Disable Receiver**

This command terminates operation of the receiver immediately — a character being received will be lost. The command has no

effect on the receiver status bits or any other control registers. If the special wake-up mode is programmed, the receiver operates even if it is disabled (see Wake-up Mode).

**CR[0] — Enable Receiver**

Enables operation of the receiver. If not in the special wake-up mode, this also forces the receiver into the search for start bit state.

**SR — Channel Status Register****SR[7] — Received Break**

This bit indicates that an all zero character of the programmed length has been received without a stop bit. Only a single FIFO position is occupied when a break is received; further entries to the FIFO are inhibited until the RxD line returns to the marking state for at least one half bit time (two successive edges of the internal or external 1× clock).

When this bit is set, the change in break bit in the ISR (ISR[3]) is set. ISR[3] is also set when the end of the break condition, as defined above, is detected.

The break detect circuitry is capable of detecting breaks that originate in the middle of a received character. However, if a break begins in the middle of a character, it must last until the end of the next character time in order for it to be detected.

**SR[6] — Framing Error (FE)**

This bit, when set, indicates that a stop bit was not detected when the corresponding data character in the FIFO was received. The stop bit check is made in the middle of the first stop bit position.

**SR[5] — Parity Error (PE)**

This bit is set when the with parity or force parity mode is programmed and the corresponding character in the FIFO was received with incorrect parity.

In the special wake-up mode, the parity error bit stores the received A/D bit.

**SR[4] — Overrun Error (OE)**

This bit, when set, indicates that one or more characters in the received data stream have been lost. It is set upon receipt of a new character when the FIFO is full and a character is already in the receive shift register waiting for an empty FIFO position. When this occurs, the character in the receive shift register (and its break detect, parity error and framing error status, if any) is lost.

This bit is cleared by a reset error status command.

**SR[3] — Transmitter Empty (TxEMT)**

This bit will be set when the transmitter underruns, i.e., both the transmit holding register (THR) and the transmit shift register are empty. However, this bit is not set until one character has been transmitted. It is set after transmission of the last stop bit of a

## Universal Asynchronous Receiver/Transmitter (UART)

SCC2691

character, if no character is in the THR awaiting transmission. It is reset when the THR is loaded by the CPU, or when the transmitter is disabled.

**SR[2] — Transmitter Ready (TxRDY)**

This bit, when set, indicates that the THR is empty and ready to be loaded with a character. This bit is cleared when the THR is loaded by the CPU and is set when the character is transferred to the transmit shift register. TxRDY is reset when the transmitter is disabled and is set when the transmitter is first enabled, e.g., characters loaded in the THR while the transmitter is disabled will not be transmitted.

**SR[1] — FIFO Full (FFULL)**

This bit is set when a character is transferred from the receive shift register to the receive FIFO and the transfer causes the FIFO to become full, i.e., all three FIFO positions are occupied. It is reset when the CPU reads the FIFO and there is no character in the receive shift register. If a character is waiting in the receive shift register because the FIFO is full, FFULL will be reset by the CPU read and then set by the transfer of the character to the FIFO, which causes all three FIFO positions to be occupied.

**SR[0] — Receiver Ready (RxRDY)**

This bit indicates that a character has been received and is waiting in the FIFO to be read by the CPU. It is set when the character is transferred from the receive shift register to the FIFO and reset when the CPU reads the RHR, and no more characters are in the FIFO.

**ACR — Auxiliary Control Register****ACR[7] — Baud Rate Generator Set Select**

This bit selects one of two sets of baud rates generated by the BRG.

Set 1: 50, 110, 134.5, 200, 300, 600, 1.05k, 1.2k, 2.4k, 4.8k, 7.2k, 9.6k, and 38.4k baud.

Set 2: 75, 110, 134.5, 150, 300, 600, 1.2k, 1.8k, 2.0k, 2.4k, 4.8k, 9.6k, and 19.2k baud.

The selected set of rates is available for use by the receiver and transmitter.

**ACR[6:4] — Counter/Timer Mode and Clock Source Select**

This field selects the operating mode of the counter/timer and its clock source as follows:

ACR[6:4]	Mode	Clock Source
0 0 0	Counter	MPI pin
0 0 1	Counter	MPI pin divided by 16
0 1 0	Counter	TxC — 1× clock of the transmitter
0 1 1	Counter	Crystal or external clock (X1/CLK) divided by 16
1 0 0	Timer	MPI pin
1 0 1	Timer	MPI pin divided by 16
1 1 0	Timer	Crystal or external clock (X1/CLK)
1 1 1	Timer	Crystal or external clock (X1/CLK) divided by 16

**ACR[3] — Power-Down Mode Select**

This bit, when set to zero, selects the power-down mode. In this mode, the 2691 oscillator is stopped and all functions requiring this clock are suspended. The contents of all registers are saved. It is recommended that the transmitter and receiver be disabled prior to placing the 2691 in this mode. Note that this bit must be set to a logic 1 after power-up.

**ACR[2:0] — MPO Output Select**

This field programs the MPO output pin to provide one of the following:

- 000 Request-to-send active low output (RTSN). This output is asserted and negated via the command register. Mode RTSN can be programmed to be automatically reset after the character in the transmitter is completely shifted out or when the receiver FIFO and receiver shift register are full using MR2[5] and MR1[7], respectively.
- 001 The counter/timer output. In the timer mode, this output is a square wave with a period of twice the value (in clock periods) of the contents of the CTUR and CTLR. In the counter mode, the output remains high until the terminal count is reached, at which time it goes low. The output returns to the high state when the counter is stopped by a stop counter command.
- 010 The 1× clock for the transmitter, which is the clock that shifts the transmitted data. If data is not being transmitted, a non-synchronized 1× clock is output.
- 011 The 16× clock for the transmitter. This is the clock selected by CSR[3:0], and is a 1× clock if CSR[3:0] = 1111.
- 100 The 1× clock for the receiver, which is the clock that samples the received data. If data is not being received, a non-synchronized 1× clock is output.
- 101 The 16× clock for the receiver. This is the clock selected by CSR[7:4], and is a 1× clock if CSR[7:4] = 1111.

110 The transmitter register empty signal, which is the complement of SR[2]. Active low output.

111 The receiver ready or FIFO full signal (complement of ISR[2]). Active low output.

**ISR — Interrupt Status Register**

This register provides the status of all potential interrupt sources. The contents of this register are masked by the interrupt mask register (IMR). If a bit in the ISR is a '1' and the corresponding bit in the IMR is also a '1', the INTRN output is asserted (low). If the corresponding bit in the IMR is a zero, the state of the bit in the ISR has no effect on the INTRN output. Note that the IMR does not mask the reading of the ISR — the true status is provided regardless of the contents of the IMR.

**ISR[7] — MPI Change-of-State**

This bit is set when a change-of-state occurs at the MPI input pin. It is reset by a reset MPI change interrupt command.

**ISR[6] — MPI Current State**

This bit provides the current state of the MPI pin. The information is unlatched and reflects the state of the pin at the time the ISR is read.

**ISR[4] — Counter Ready**

In the counter mode of operation, this bit is set when the counter reaches terminal count and is reset when the counter is stopped by a stop counter command. It is initialized to '0' when the chip is reset.

In the timer mode, this bit is set once each cycle of the generated square wave (every other time the C/T reaches zero count). The bit is reset by a stop counter command. The command, however, does not stop the C/T.

**ISR[3] — Change in Break**

This bit, when set, indicates that the receiver has detected the beginning or the end of a received break. It is reset when the CPU issues a reset break change interrupt command.

**ISR[2] — Receiver Ready or FIFO Full**

The function of this bit is programmed by MR1[6]. If programmed as receiver ready, it indicates that a character has been received and is waiting in the FIFO to be read by the CPU. It is set when the character is transferred from the receive shift register to the FIFO and reset when the CPU reads the receiver FIFO. If the FIFO contains more characters, the bit will be set again after the FIFO is read. If programmed as FIFO full, it is set when a character is transferred from the receive holding register to the receive FIFO and the transfer causes the FIFO to become full, i.e., all three FIFO positions are occupied. It is reset when FIFO is read and there is no character in the receiver shift register. If there

---

# Universal Asynchronous Receiver/Transmitter (UART)

---

SCC2691

is a character waiting in the receive shift register because the FIFO is full, the bit is set again when the waiting character is transferred into the FIFO.

**ISR[1] — Transmitter Empty**

This bit is a duplicate of TxEMT (SR[3]).

**ISR[0] — Transmitter Ready**

This bit is a duplicate of TxRDY (SR[2]).

**IMR — Interrupt Mask Register**

The programming of this register selects which bits in the ISR cause an interrupt output. If a bit in the ISR is a '1' and the corresponding bit in the IMR is a '1', the INTRN output is asserted (low). If the corresponding bit in the IMR is a zero, the state of the bit in the ISR has no effect on the INTRN output. Note that the IMR does not mask reading of the ISR.

**CTUR AND CTLR — Counter/Timer Registers**

The CTUR and CTLR hold the eight MSBs and eight LSBs, respectively, the value to be used by the counter/timer in either the counter or timer modes of operation. The minimum value which may be loaded is 0002<sub>16</sub>.

In the timer (programmable divider) mode, the C/T generates a square wave whose period is twice the value (in clock periods) of the CTUR and CTLR. If the value in CTUR or CTLR is changed, the current half-period will not be affected, but subsequent half-periods will be.

The counter ready status bit (ISR[4]) is set once each cycle of the square wave. The bit is reset by a stop counter command. The command, however, does not stop the C/T. The generated square wave is output on MPO if it is programmed to be the C/T output.

In the counter mode, the C/T counts down the number of pulses loaded into CTUR and CTLR. Counting begins upon receipt of a start C/T command. Upon reaching the terminal count, the counter ready interrupt bit (ISR[4]) is set. The counter continues counting past the terminal count until stopped by the CPU. If MPO is programmed to be the output of the C/T, the output remains high until the terminal count is reached, at which time it goes low.

The output returns to the high state and ISR[4] is cleared when the counter is stopped by a stop counter command. The CPU may change the values of CTUR and CTLR at any time, but the new count becomes effective only on the next start counter command. If new values have not been loaded, the previous count values are preserved and used for the next count cycle.

## Universal Asynchronous Receiver/Transmitter (UART)

SCC2691

ABSOLUTE MAXIMUM RATINGS<sup>1</sup>

SYMBOL	PARAMETER	RATING	UNIT
T <sub>A</sub>	Operating ambient temperature <sup>2</sup> range	0 to +70	°C
T <sub>STG</sub>	Storage temperature range	-65 to +150	°C
V <sub>CC</sub>	Voltage from V <sub>CC</sub> to GND <sup>3</sup>	-0.5 to +7.0	V
V <sub>S</sub>	Voltage from any pin to ground <sup>3</sup>	-0.5 to V <sub>CC</sub> ± 10%	V
P <sub>D</sub>	Power dissipation	21	mW

DC ELECTRICAL CHARACTERISTICS T<sub>A</sub> = 0°C to +70°C, V<sub>CC</sub> = +5V ± 5%<sup>4, 5, 6</sup>

SYMBOL	PARAMETER	TEST CONDITIONS	LIMITS			UNIT
			Min	Typ	Max	
V <sub>IL</sub> V <sub>IH</sub>	Input low voltage Input high voltage All except X1/CLK X1/CLK		2 0.9V <sub>CC</sub>		0.8 V <sub>CC</sub>	V V V
V <sub>OL</sub> V <sub>OH</sub> <sup>7</sup>	Output low voltage Output high voltage (except open drain outputs)	I <sub>OL</sub> = 2.4mA I <sub>OH</sub> = -400µA			0.4	V V
I <sub>IL</sub> I <sub>LL</sub> I <sub>OD</sub>	Input leakage current Data bus 3-State leakage current Open drain output leakage current	V <sub>IN</sub> = 0 to V <sub>CC</sub> V <sub>O</sub> = 0.4 to V <sub>CC</sub> V <sub>O</sub> = 0.4 to V <sub>CC</sub>	-10 -10 -10		10 10 10	µA µA µA
I <sub>X1L</sub> I <sub>X1H</sub>	X1/CLK low input current X1/CLK high input current	V <sub>IN</sub> = 0, X2 floated V <sub>IN</sub> = V <sub>CC</sub> , X2 floated	-100 0	-30 +30	0 100	µA µA
<b>When oscillator is in power-down mode:</b>						
I <sub>X1H</sub> I <sub>X2L</sub> I <sub>X2H</sub>	X1/CLK high input current X2 low output current X2 high output current	V <sub>IN</sub> = V <sub>CC</sub> , X2 floated V <sub>OUT</sub> = 0, X1/CLK = V <sub>CC</sub> V <sub>OUT</sub> = V <sub>CC</sub> , X1/CLK = 0V	2	6	10 100 100	mA µA µA
I <sub>CC</sub>	Power supply current Standby			0.8	4 500	mA µA

## NOTES:

- Stresses above those listed under Absolute Maximum Ratings may cause permanent damage to the device. This is stress rating only and functional operation of the device at these or at any other condition above those indicated in the operation section of this specification is not implied.
- For operating at elevated temperatures, the device must be derated based on +150°C maximum junction temperature.
- This product includes circuitry specifically designed for the protection of its internal devices from damaging effects of excessive static charge. Nonetheless, it is suggested that conventional precautions be taken to avoid applying any voltages larger than the rated maxima.
- Parameters are valid over specified temperature range.
- All voltage measurements are referenced to ground (GND). For testing, all input signals swing between 0.4V and 2.4V with a transition time of 20ns maximum. For X1/CLK, this swing is between 0.4V and 4.4V. All time measurements are referenced at input voltages of 0.8V and 2V and output voltages of 0.8V and 2V as appropriate.
- Typical values are at +25°C, typical supply voltages, and typical processing parameters.
- Test condition for outputs: C<sub>L</sub> = 150pF, except interrupt outputs: C<sub>L</sub> = 50pF, R<sub>L</sub> = 2.7kΩ to V<sub>CC</sub>.
- Timing is illustrated and referenced to the WRN and RDN inputs. The device may also be operated with CEN as the 'strobing' input. In this case, all timing specifications apply referenced to the falling and rising edges of CEN. CEN and RDN (also CEN and WRN) are OR'ed internally. As a consequence, the signal asserted last initiates the cycle and the signal negated first terminates the cycle.
- If CEN is used as the 'strobing' input, this parameter defines the minimum high time between one CEN and the next. The RDN signal must be negated for t<sub>RWD</sub> to guarantee that any status register changes are valid.
- Consecutive write operations to the same command require at least three edges of the X1 clock between writes.

## Universal Asynchronous Receiver/Transmitter (UART)

SCC2691

AC ELECTRICAL CHARACTERISTICS  $T_A = 0^\circ\text{C}$  to  $+70^\circ\text{C}$ ,  $V_{CC} = +5\text{V} \pm 5\%$ <sup>4, 5, 6, 7</sup>

SYMBOL	PARAMETER	TENTATIVE LIMITS			UNIT
		Min	Typ	Max	
<b>Reset timing (Figure 1)</b>					
$t_{RES}$	RESET pulse width	100			ns
<b>Bus timing (Figure 2)<sup>8</sup></b>					
$t_{AS}$	A0 – A2 setup time to RDN, WRN low	10			ns
$t_{AH}$	A0 – A2 hold time from RDN, WRN high	0			ns
$t_{CS}$	CEN setup time to RDN, WRN low	0			ns
$t_{CH}$	CEN hold time from RDN, WRN high	0			ns
$t_{RW}$	WRN, RDN pulse width	225			ns
$t_{DD}$	Data valid after RDN low			180	ns
$t_{DF}$	Data bus floating after RDN high			65	ns
$t_{DS}$	Data setup time before WRN high	100			ns
$t_{DH}$	Data hold time after WRN high	30			ns
$t_{RWD}$ <sup>10</sup>	Time between READs and/or WRITEs	200			ns
<b>MPI and MPO timing (Figure 3)<sup>8</sup></b>					
$t_{PS}$	MPI input setup time before RDN low	0			ns
$t_{PH}$	MPI input hold time after RDN high	0			ns
$t_{PD}$	MPO output valid after WRN high			370	ns
<b>Interrupt timing (Figure 4)</b>					
$t_{IR}$	INTRN negated: Read RHR (RxRDY/FFULL interrupt) Write THR (TxRDY, TxEMT interrupt) Reset command (Break change interrupt) Reset command (MPI change interrupt) Stop C/T command (counter interrupt) Write IMR (clear of interrupt mask bit)			370 370 370 370 370 270	ns ns ns ns ns ns
<b>Clock timing (Figure 5)</b>					
$t_{CLK}$	X1/CLK high or low time	100			ns
$f_{CLK}$	X1/CLK frequency	2.0	3.6864	4.0	MHz
$t_{CTC}$	Counter/timer clock high or low time	100			ns
$f_{CTC}$	Counter/timer clock frequency	100		4.0M	Hz
$t_{RX}$	RxC high or low time	220			ns
$f_{RX}$	RxC frequency (16×)	100		2.0M	Hz
	(1×)	100		1.0M	Hz
$t_{TX}$	TxC high or low time	220			ns
$f_{TX}$	TxC frequency (16×)	0		2.0M	Hz
	(1×)	0		1.0M	Hz
<b>Transmitter timing (Figure 6)</b>					
$t_{TXD}$	TxD output delay from TxC low			350	ns
$t_{TCS}$	TxC output delay from TxD output data	0		150	ns
<b>Receiver timing (Figure 7)</b>					
$t_{RXS}$	RxD data setup time to RxC high	240			ns
$t_{RXH}$	RxD data hold time from RxC high	200			ns

Universal Asynchronous Receiver/Transmitter (UART)

SCC2691

**2**

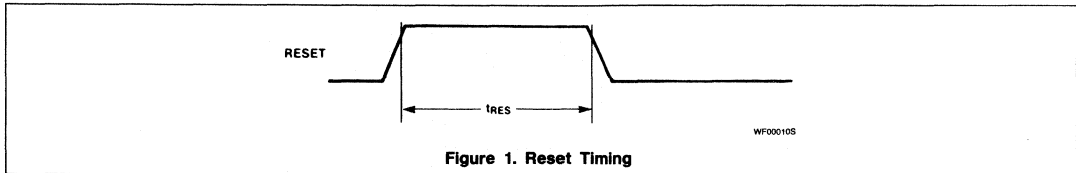

Figure 1. Reset Timing

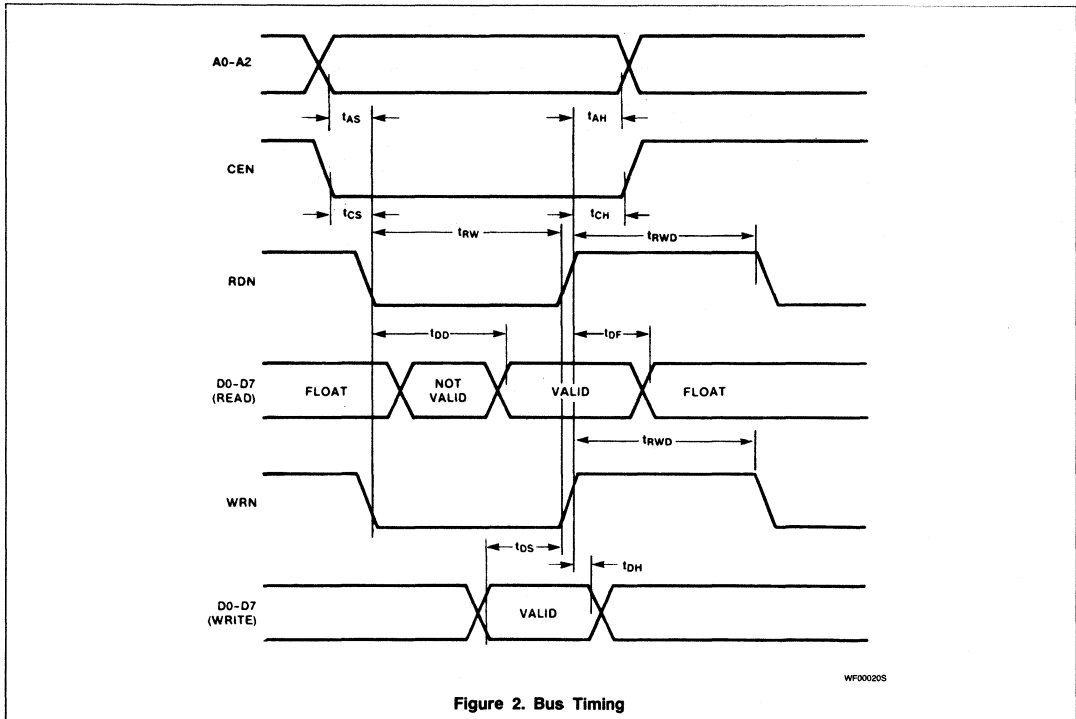

Figure 2. Bus Timing

# Universal Asynchronous Receiver/Transmitter (UART)

SCC2691

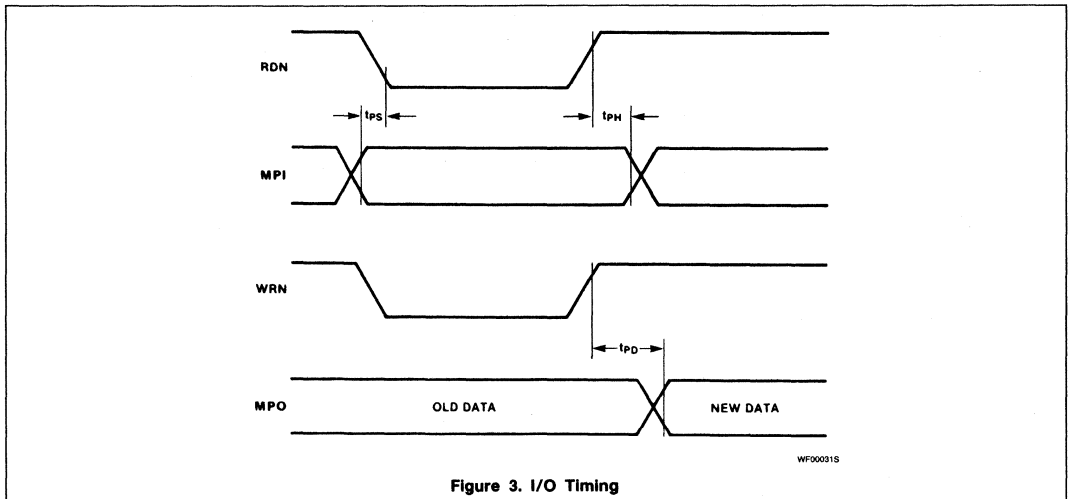
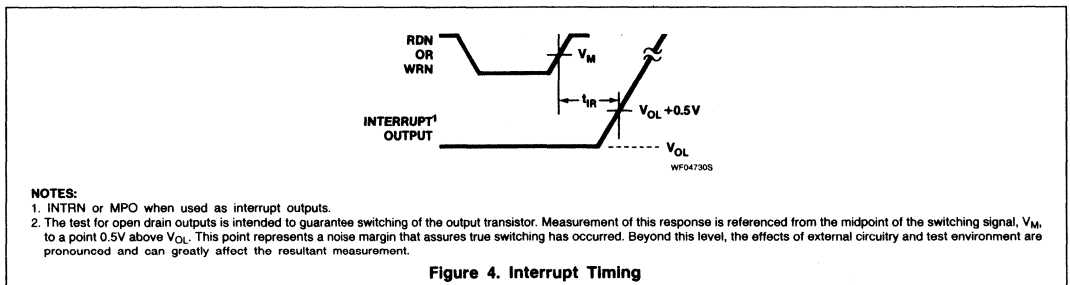

Figure 3. I/O Timing



**NOTES:**

1. INTRN or MPO when used as interrupt outputs.
2. The test for open drain outputs is intended to guarantee switching of the output transistor. Measurement of this response is referenced from the midpoint of the switching signal,  $V_M$ , to a point 0.5V above  $V_{OL}$ . This point represents a noise margin that assures true switching has occurred. Beyond this level, the effects of external circuitry and test environment are pronounced and can greatly affect the resultant measurement.

Figure 4. Interrupt Timing

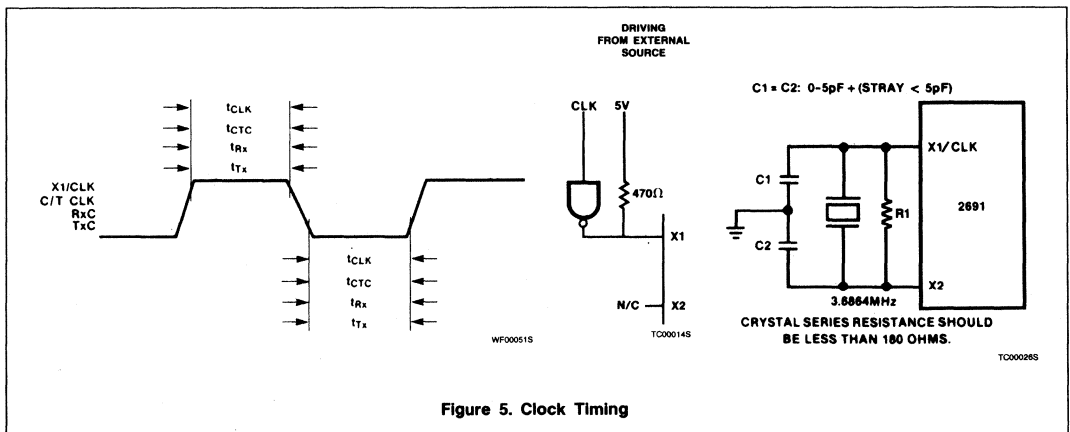

Figure 5. Clock Timing



Universal Asynchronous Receiver/Transmitter (UART)

SCC2691

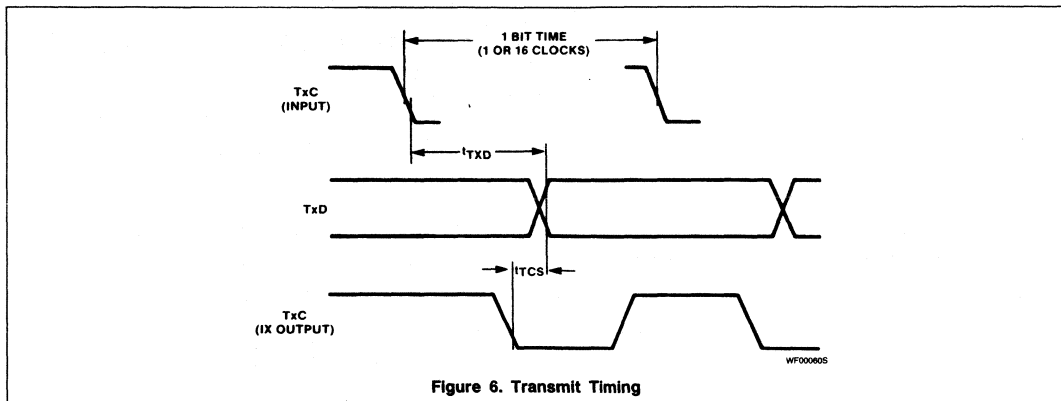

Figure 6. Transmit Timing

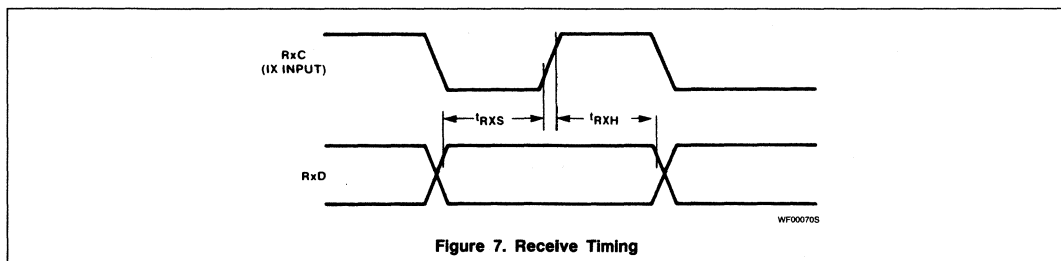
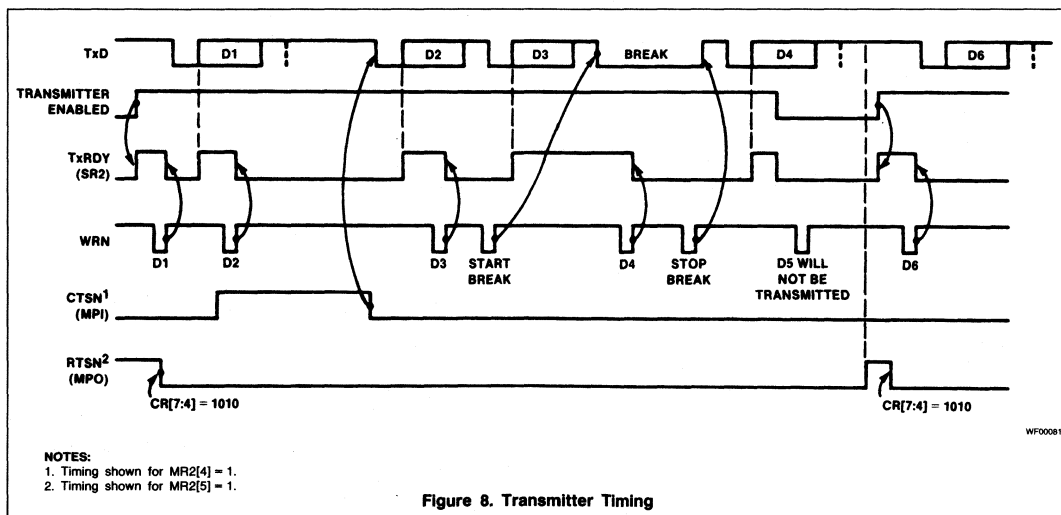

Figure 7. Receive Timing



- NOTES:  
 1. Timing shown for MR2[4] = 1.  
 2. Timing shown for MR2[5] = 1.

Figure 8. Transmitter Timing

# Universal Asynchronous Receiver/Transmitter (UART)

SCC2691

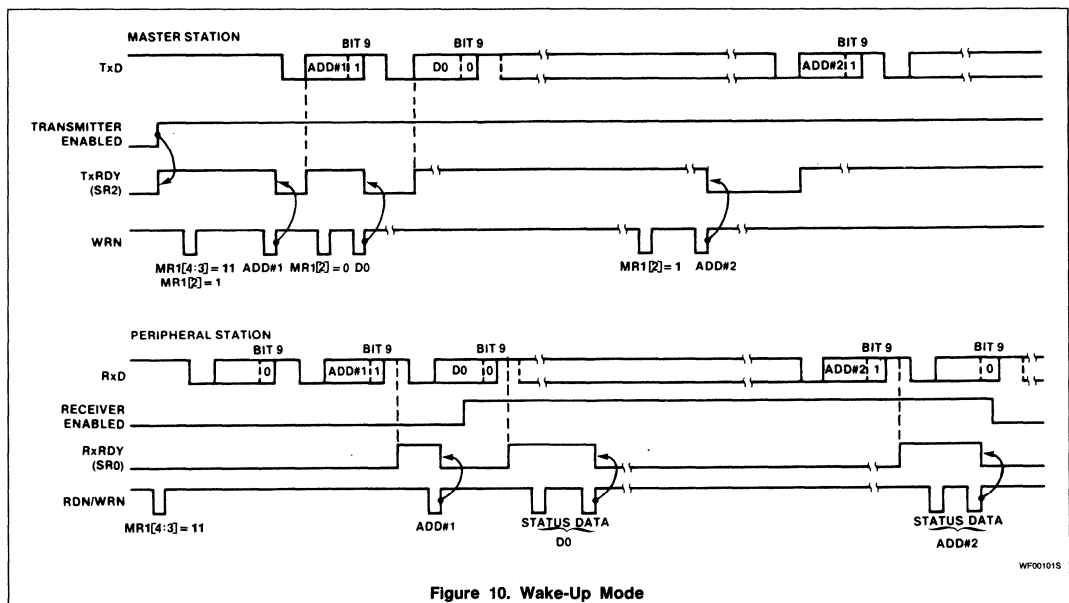
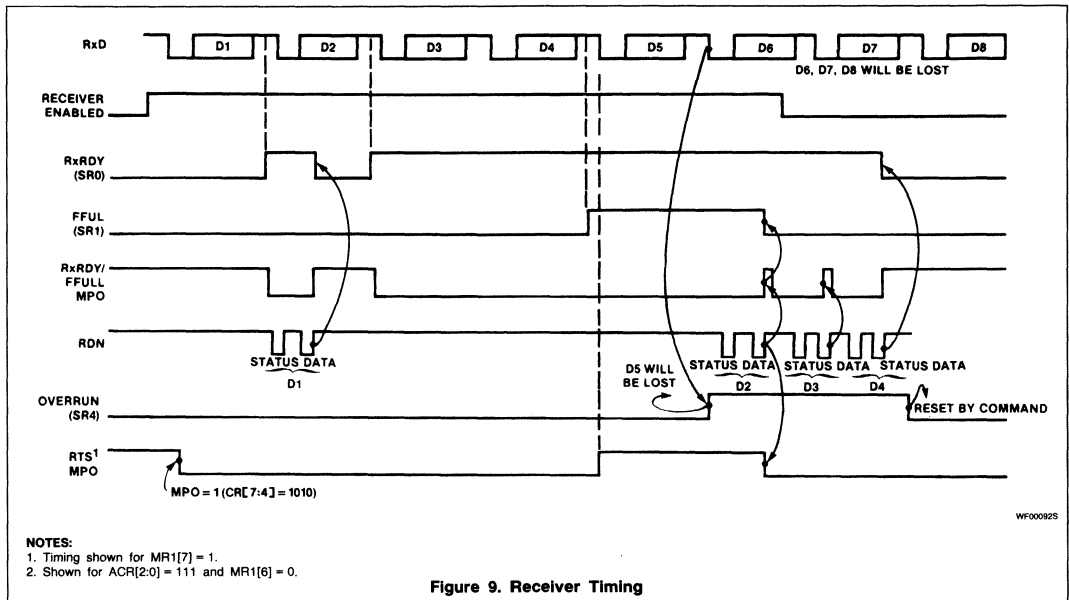

# SCC2692

## Dual Asynchronous Receiver/Transmitter (DUART)

Preliminary Specification

### Microprocessor Products

#### DESCRIPTION

The Signetics SCC2692 Dual Universal Asynchronous Receiver/Transmitter (DUART) is a single-chip CMOS-LSI communications device that provides two independent full-duplex asynchronous receiver/transmitter channels in a single package. It interfaces directly with microprocessors and may be used in a polled or interrupt driven system.

The operating mode and data format of each channel can be programmed independently. Additionally, each receiver and transmitter can select its operating speed as one of eighteen fixed baud rates, a  $16\times$  clock derived from a programmable counter/timer, or an external  $1\times$  or  $16\times$  clock. The baud rate generator and counter/timer can operate directly from a crystal or from external clock inputs. The ability to independently program the operating speed of the receiver and transmitter make the DUART particularly attractive for dual-speed channel applications such as clustered terminal systems.

Each receiver is quadruply buffered to minimize the potential of receiver overrun or to reduce interrupt overhead in interrupt driven systems. In addition, a flow control capability is provided to disable a remote DUART transmitter when the buffer of the receiving device is full.

#### FEATURES

- Dual full-duplex asynchronous receiver/transmitter
- Quadruple buffered receiver data registers
- Programmable data format
  - 5 to 8 data bits plus parity
  - Odd, even, no parity or force parity
  - 1, 1.5 or 2 stop bits programmable in  $\frac{1}{16}$ -bit increments
- Programmable baud rate for each receiver and transmitter selectable from:

- 18 fixed rates: 50 to 38.4k baud
- One user-defined rate derived from programmable timer/counter
- External  $1\times$  or  $16\times$  clock
- Parity, framing, and overrun error detection
- False start bit detection
- Line break detection and generation
- Programmable channel mode
  - Normal (full-duplex)
  - Automatic echo
  - Local loopback
  - Remote loopback
- Multi-function programmable 16-bit counter/timer
- Multi-function 7-bit input port
  - Can serve as clock or control inputs
  - Change of state detection on four inputs
- Multi-function 8-bit output port
  - Individual bit set/reset capability
  - Outputs can be programmed to be status/interrupt signals
- Versatile interrupt system
  - Single interrupt output with eight maskable interrupting conditions
  - Output port can be configured to provide a total of up to six separate wire-ORable interrupt outputs
- Maximum data transfer:  $1\times - 1\text{MB/s}$ ,  $16\times - 125\text{kB/s}$
- Automatic wake-up mode for multidrop applications
- Start-end break interrupt/status
- Detects break which originates in the middle of a character
- On-chip crystal oscillator
- TTL compatible
- Single +5V power supply
- Power down mode
- Receiver timeout mode

#### PIN CONFIGURATIONS

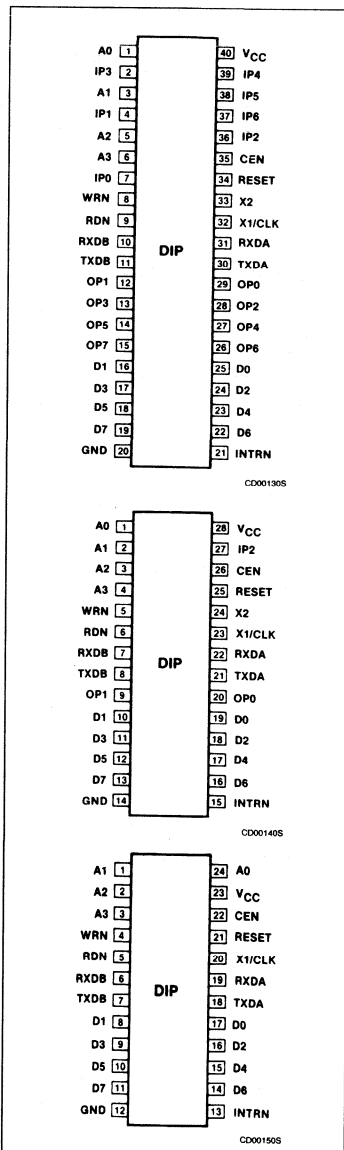

# Dual Asynchronous Receiver/Transmitter (DUART)

# SCC2692

## PIN CONFIGURATIONS (Continued)

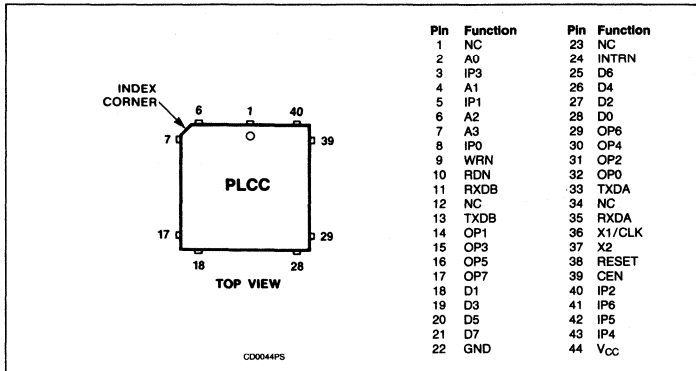

Also provided on the SCC2692 are a multipurpose 7-bit input port and a multipurpose 8-bit output port. These can be used as general purpose I/O ports or can be assigned specific functions (such as clock inputs or status/interrupt outputs) under program control.

The SCC2692 is available in four package versions: 40-pin and 28-pin, both 0.6" wide DIPs; a compact 24-pin 0.4" wide DIP; and a 44-pin PLCC.

## ORDERING INFORMATION

PACKAGES	V <sub>CC</sub> = +5V ± 5%, T <sub>A</sub> = 0°C to +70°C			
	24-Pin <sup>1</sup>	28-Pin <sup>2</sup>	40-Pin <sup>2</sup>	44-Pin
Ceramic DIP	Not available	SCC2692AC1128	SCC2692AC1140	Not available
Plastic DIP	SCC2692AC1N24	SCC2692AC1N28	SCC2692AC1N40	Not available
Plastic LCC	Not available	Not available	Not available	SCC2692AC1A44

### NOTES:

1. 400 mil wide DIP
2. 600 mil wide DIP

## PIN DESCRIPTION

MNEMONIC	APPLICABLE			TYPE	NAME AND FUNCTION
	40	28	24		
D0 - D7	X	X	X	I/O	<b>Data Bus:</b> Bidirectional 3-State data bus used to transfer commands, data and status between the DUART and the CPU. D0 is the least significant bit.
CEN	X	X	X	I	<b>Chip Enable:</b> Active low input signal. When low, data transfers between the CPU and the DUART are enabled on D0 - D7 as controlled by the WRN, RDN and A0 - A3 inputs. When high, places the D0 - D7 lines in the 3-State condition.
WRN	X	X	X	I	<b>Write Strobe:</b> When low and CEN is also low, the contents of the data bus is loaded into the addressed register. The transfer occurs on the rising edge of the signal.
RDN	X	X	X	I	<b>Read Strobe:</b> When low and CEN is also low, causes the contents of the addressed register to be presented on the data bus. The read cycle begins on the falling edge of RDN.
A0 - A3	X	X	X	I	<b>Address Inputs:</b> Select the DUART internal registers and ports for read/write operations.
RESET	X	X	X	I	<b>Reset:</b> A high level clears internal registers (SRA, SRB, IMR, ISR, OPR, OPCR), puts OP0 - OP7 in the high state, stops the counter/timer, and puts channels A and B in the inactive state, with the TxDA and TxDB outputs in the mark (high) state.
INTRN	X	X	X	O	<b>Interrupt Request:</b> Active low, open drain, output which signals the CPU that one or more of the eight maskable interrupting conditions are true.
X1/CLK	X	X	X	I	<b>Crystal 1:</b> Crystal or external clock input. A crystal or clock of the specified limits must be supplied at all times. When a crystal is used, a capacitor must be connected from this pin to ground (see Figure 5).
X2	X	X		I	<b>Crystal 2:</b> Connection for other side of the crystal. When a crystal is used, a capacitor must be connected from this pin to ground (see Figure 5). If X1/CLK is driven from an external source, this pin must be open.
RxDA	X	X	X	I	<b>Channel A Receiver Serial Data Input:</b> The least significant bit is received first. 'Mark' is high, 'space' is low.

## Dual Asynchronous Receiver/Transmitter (DUART)

SCC2692

## PIN DESCRIPTION (Continued)

MNEMONIC	APPLICABLE			TYPE	NAME AND FUNCTION
	40	28	24		
RxDB	X	X	X	I	<b>Channel B Receiver Serial Data Input:</b> The least significant bit is received first. 'Mark' is high, 'space' is low.
TxDA	X	X	X	O	<b>Channel A Transmitter Serial Data Output:</b> The least significant bit is transmitted first. This output is held in the 'mark' condition when the transmitter is disabled, idle, or when operating in local loopback mode. 'Mark' is high, 'space' is low.
TxDB	X	X	X	O	<b>Channel B Transmitter Serial Data Output:</b> The least significant bit is transmitted first. This output is held in the 'mark' condition when the transmitter is disabled, idle, or when operating in local loopback mode. 'Mark' is high, 'space' is low.
OP0	X	X		O	<b>Output 0:</b> General purpose output, or channel A request to send (RTSAN, active low). Can be deactivated automatically on receive or transmit.
OP1	X	X		O	<b>Output 1:</b> General purpose output, or channel B request to send (RTSBN, active low). Can be deactivated automatically on receive or transmit.
OP2	X			O	<b>Output 2:</b> General purpose output, or channel A transmitter 1× or 16× clock output, or channel A receiver 1× clock output.
OP3	X			O	<b>Output 3:</b> General purpose output, or open drain, active low counter/timer output, or channel B transmitter 1× clock output, or channel B receiver 1× clock output.
OP4	X			O	<b>Output 4:</b> General purpose output, or channel A open drain, active low, RxRDYA/FFULLA output.
OP5	X			O	<b>Output 5:</b> General purpose output, or channel B open drain, active low, RxRDYB/FFULLB output.
OP6	X			O	<b>Output 6:</b> General purpose output, or channel A open drain, active low, TxRDYA output.
OP7	X			O	<b>Output 7:</b> General purpose output, or channel B open drain, active low, TxRDYB output.
IP0	X			I	<b>Input 0:</b> General purpose input, or channel A clear to send active low input (CTSAN).
IP1	X			I	<b>Input 1:</b> General purpose input, or channel B clear to send active low input (CTSBN).
IP2	X	X		I	<b>Input 2:</b> General purpose input, or counter/timer external clock input.
IP3	X			I	<b>Input 3:</b> General purpose input, or channel A transmitter external clock input (TxCA). When the external clock is used by the transmitter, the transmitted data is clocked on the falling edge of the clock.
IP4	X			I	<b>Input 4:</b> General purpose input, or channel A receiver external clock input (RxCA). When the external clock is used by the receiver, the received data is sampled on the rising edge of the clock.
IP5	X			I	<b>Input 5:</b> General purpose input, or channel B transmitter external clock input (TxCB). When the external clock is used by the transmitter, the transmitted data is clocked on the falling edge of the clock.
IP6	X			I	<b>Input 6:</b> General purpose input or channel B receiver external clock input (RxCB). When the external clock is used by the receiver, the received data is sampled on the rising edge of the clock.
V <sub>CC</sub>	X	X	X	I	<b>Power Supply:</b> +5V supply input
GND	X	X	X	I	<b>Ground</b>

# Dual Asynchronous Receiver/Transmitter (DUART)

SCC2692

## BLOCK DIAGRAM

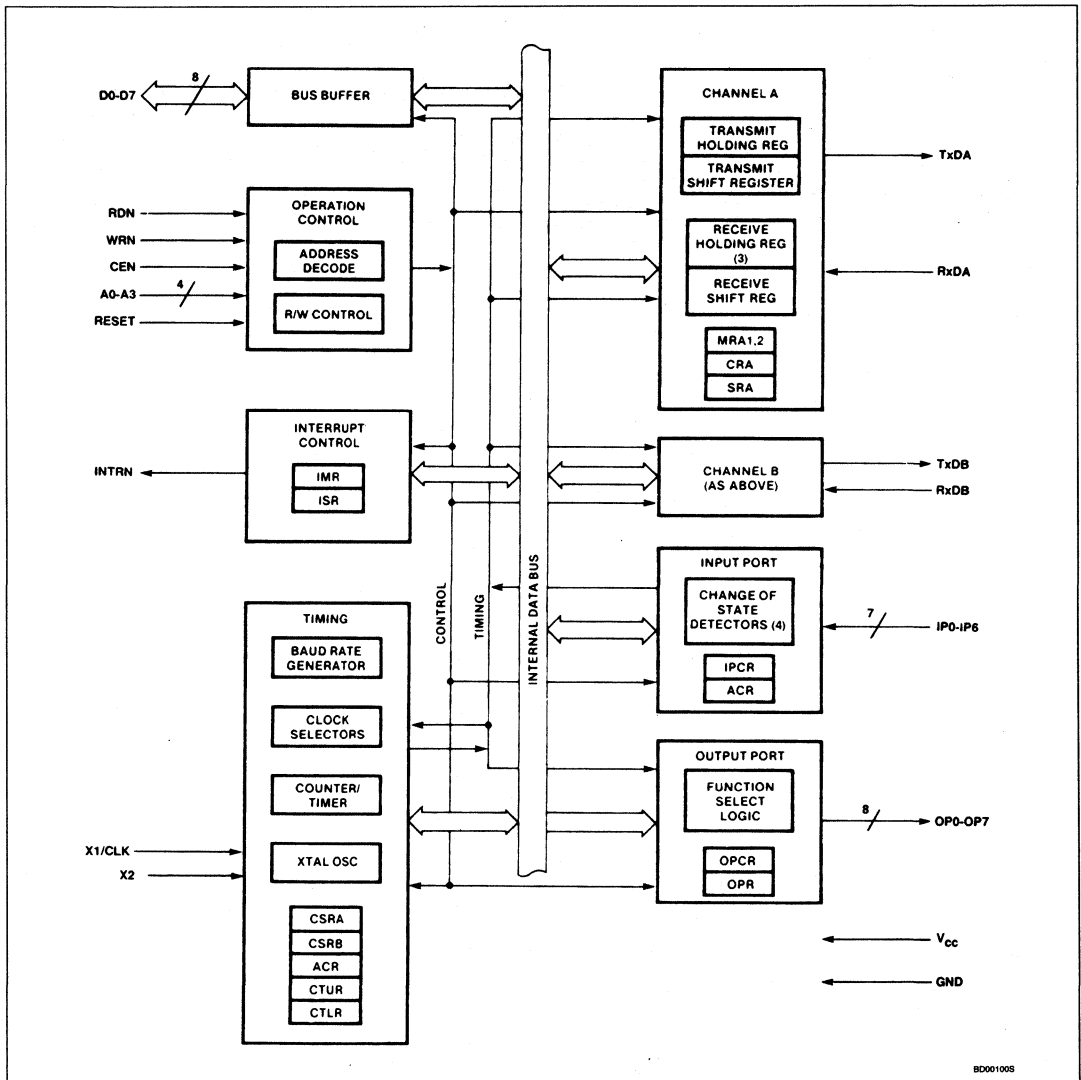

# Dual Asynchronous Receiver/Transmitter (DUART)

SCC2692

## BLOCK DIAGRAM

The 2692 DUART consists of the following eight major sections: data bus buffer, operation control, interrupt control, timing, communications channels A and B, input port and output port. Refer to the block diagram.

### Data Bus Buffer

The data bus buffer provides the interface between the external and internal data buses. It is controlled by the operation control block to allow read and write operations to take place between the controlling CPU and the DUART.

### Operation Control

The operation control logic receives operation commands from the CPU and generates appropriate signals to internal sections to control device operation. It contains address decoding and read and write circuits to permit communications with the microprocessor via the data bus buffer.

### Interrupt Control

A single active low interrupt output (INTRN) is provided which is activated upon the occurrence of any of eight internal events. Associated with the interrupt system are the interrupt mask register (IMR) and the interrupt status register (ISR). The IMR may be programmed to select only certain conditions to cause INTRN to be asserted. The ISR can be read by the CPU to determine all currently active interrupting conditions.

Outputs OP3–OP7 can be programmed to provide discrete interrupt outputs for the transmitters, receivers, and counter/timer.

### Timing Circuits

The timing block consists of a crystal oscillator, a baud rate generator, a programmable 16-bit counter/timer, and four clock selectors. The crystal oscillator operates directly from a 3.6864MHz crystal connected across the X1/CLK and X2 inputs. If an external clock of the appropriate frequency is available, it may be connected to X1/CLK. The clock serves as the basic timing reference for the baud rate generator (BRG), the counter/timer, and other internal circuits. A clock signal within the limits specified in the specifications section of this data sheet must always be supplied to the DUART.

If an external clock is used instead of a crystal, X1 should be driven using a configuration similar to the one in Figure 5. The input clock must be capable of attaining a  $V_{IH}$  of 4.4V.

The baud rate generator operates from the oscillator or external clock input and is capable of generating 18 commonly used data communications baud rates ranging from 50 to 38.4k baud. The clock outputs from the BRG are at  $16\times$  the actual baud rate. The

counter/timer can be used as a timer to produce a  $16\times$  clock for any other baud rate by counting down the crystal clock or an external clock. The four clock selectors allow the independent selection, for each receiver and transmitter, of any of these baud rates or an external timing signal.

The counter/timer (C/T) can be programmed to use one of several timing sources as its input. The output of the C/T is available to the clock selectors and can also be programmed to be output at OP3. In the counter mode, the contents of the C/T can be read by the CPU and it can be stopped and started under program control. In the timer mode, the C/T acts as a programmable divider.

### Communications Channels A And B

Each communications channel of the 2692 comprises a full-duplex asynchronous receiver/transmitter (UART). The operating frequency for each receiver and transmitter can be selected independently from the baud rate generator, the counter timer, or from an external input.

The transmitter accepts parallel data from the CPU, converts it to a serial bit stream, inserts the appropriate start, stop, and optional parity bits and outputs a composite serial stream of data on the TxD output pin. The receiver accepts serial data on the RxD pin, converts this serial input to parallel format, checks for start bit, stop bit, parity bit (if any), or break condition and sends an assembled character to the CPU.

### Input Port

The input port pulse detection circuitry uses a 38.4kHz sampling clock derived from one of the baud rate generator taps. This results in a sampling period of slightly more than  $25\mu\text{s}$  (this assumes that the clock input is 3.6864MHz). The detection circuitry, in order to guarantee that a true change in level has occurred, requires two successive samples at the new logic level to be observed. As a consequence, the minimum duration of the signal change is  $25\mu\text{s}$  if the transition occurs "coincident with the first sample pulse." The  $50\mu\text{s}$  time refers to the situation in which the change of state is "just missed" and the first change of state is not detected until  $25\mu\text{s}$  later.

The inputs to this unlatched 7-bit port can be read by the CPU by performing a read operation at address D16. A high input results in a logic 1 while a low input results in a logic 0. D7 will always be read as a logic 1. The pins of this port can also serve as auxiliary inputs to certain portions of the DUART logic.

Four change-of-state detectors are provided which are associated with inputs IP3, IP2, IP1, and IP0. A high-to-low or low-to-high transi-

tion of these inputs, lasting longer than  $25 - 50\mu\text{s}$ , will set the corresponding bit in the input port change register. The bits are cleared when the register is read by the CPU. Any change of state can also be programmed to generate an interrupt to the CPU.

### Output Port

The 8-bit multi-purpose output port can be used as a general purpose output port, in which case the outputs are the complements of the output port register (OPR).  $\text{OPR}[n] = 1$  results in  $\text{OP}[n] = \text{low}$  and vice versa. Bits of the OPR can be individually set and reset. A bit is set by performing a write operation at address E16 with the accompanying data specifying the bits to be set (1 = set, 0 = no change). Likewise, a bit is reset by a write at address F16 with the accompanying data specifying the bits to be reset (1 = reset, 0 = no change).

Outputs can be also individually assigned specific functions by appropriate programming of the channel A mode registers (MR1A, MR2A), the channel B mode registers (MR1B, MR2B), and the output port configuration register (OPCR).

## OPERATION

### Transmitter

The 2692 is conditioned to transmit data when the transmitter is enabled through the command register. The 2692 indicates to the CPU that it is ready to accept a character by setting the TxRDY bit in the status register. This condition can be programmed to generate an interrupt request at OP6 or OP7 and INTRN. When a character is loaded into the transmit holding register (THR), the above conditions are negated. Data is transferred from the holding register to transmit shift register when it is idle or has completed transmission of the previous character. The TxRDY conditions are then asserted again which means one full character time of buffering is provided. Characters cannot be loaded into the THR while the transmitter is disabled.

The transmitter converts the parallel data from the CPU to a serial bit stream on the TxD output pin. It automatically sends a start bit followed by the programmed number of data bits, an optional parity bit, and the programmed number of stop bits. The least significant bit is sent first. Following the transmission of the stop bits, if a new character is not available in the THR, the TxD output remains high and the TxEMT bit in the status register (SR) will be set to 1. Transmission resumes and the TxEMT bit is cleared when the CPU loads a new character into the THR. If the transmitter is disabled, it continues operating until the character currently being transmitted is completely sent out. The trans-

## Dual Asynchronous Receiver/Transmitter (DUART)

SCC2692

mitter can be forced to send a continuous low condition by issuing a send break command.

The transmitter can be reset through a software command. If it is reset, operation ceases immediately and the transmitter must be enabled through the command register before resuming operation. If CTS operation is enabled, the CTSN input must be low in order for the character to be transmitted. If it goes high in the middle of a transmission, the character in the shift register is transmitted and TxDA then remains in the marking state until CTSN goes low. The transmitter can also control the deactivation of the RTSN output. If programmed, the RTSN output will be reset one bit time after the character in the transmit shift register and transmit holding register (if any) are completely transmitted, if the transmitter has been disabled.

### Receiver

The 2692 is conditioned to receive data when enabled through the command register. The receiver looks for a high-to-low (mark-to-space) transition of the start bit on the RxD input pin. If a transition is detected, the state of the RxD pin is sampled each  $16 \times$  clock for  $7\frac{1}{2}$  clocks ( $16 \times$  clock mode) or at the next rising edge of the bit time clock ( $1 \times$  clock mode). If RxD is sampled high, the start bit is invalid and the search for a valid start bit begins again. If RxD is still low, a valid start bit is assumed and the receiver continues to sample the input at one bit time intervals at the theoretical center of the bit, until the proper number of data bits and the parity bit (if any) have been assembled, and one stop bit has been detected. The least significant bit is received first. The data is then transferred to the receive holding register (RHR) and the RxRDY bit in the SR is set to a 1. This condition can be programmed to generate an interrupt at OP4 or OP5 and INTRN. If the character length is less than eight bits, the most significant unused bits in the RHR are set to zero.

After the stop bit is detected, the receiver will immediately look for the next start bit. However, if a non-zero character was received without a stop bit (framing error) and RxD remains low for one half of the bit period after the stop bit was sampled, then the receiver operates as if a new start bit transition had been detected at that point (one-half bit time after the stop bit was sampled).

The parity error, framing error, overrun error and received break state (if any) are strobed into the SR at the received character boundary before the RxRDY status bit is set. If a break condition is detected (FxD is low for the entire character including the stop bit), a character consisting of all zeros will be loaded into the RHR and the received break bit in the SR is set to 1. The RxD input must return

to a high condition for at least one-half bit time before a search for the next start bit begins.

The RHR consists of a first-in-first-out (FIFO) stack with a capacity of three characters. Data is loaded from the receive shift register into the topmost empty position of the FIFO. The RxRDY bit in the status register is set whenever one or more characters are available to be read, and a FFULL status bit is set if all three stack positions are filled with data. Either of these bits can be selected to cause an interrupt. A read of the RHR outputs the data at the top of the FIFO. After the read cycle, the data FIFO and its associated status bits (see below) are "popped", thus emptying a FIFO position for new data.

In addition to the data word, three status bits (parity error, framing error, and received break) are also appended to each data character in the FIFO (overrun is not). Status can be provided in two ways, as programmed by the error mode control bit in the mode register. In the "character" mode, status is provided on a character-by-character basis; the status applies only to the character at the top of the FIFO. In the "block" mode, the status provided in the SR for these three bits is the logical-OR of the status for all characters coming to the top of the FIFO since the last "reset error" command was issued. In either mode reading the SR does not affect the FIFO. The FIFO is "popped" only when the RHR is read. Therefore the status register should be read prior to reading the FIFO.

If the FIFO is full when a new character is received, that character is held in the receive shift register until a FIFO position is available. If an additional character is received while this state exists, the contents of the FIFO are not affected; the character previously in the shift register is lost and the overrun error status bit (SR[4]) will be set-upon receipt of the start bit of the new (overrunning) character.

The receiver can control the deactivation of RTS. If programmed to operate in this mode, the RTSN output will be negated when a valid start bit was received and the FIFO is full. When a FIFO position becomes available, the RTSN output will be re-asserted automatically. This feature can be used to prevent an overrun, in the receiver, by connecting the RTSN output to the CTSN input of the transmitting device.

If the receiver is disabled, the FIFO characters can be read. However, no additional characters can be received until the receiver is enabled again. If the receiver is reset, the FIFO and all of the receiver status, and the corresponding output ports and interrupt are reset. No additional characters can be received until the receiver is enabled again.

### Timeout Mode

Under certain conditions, the user may want to set the receiver to interrupt the CPU when the receive FIFO becomes full. This can be accomplished by programming MR1[6] = 1. If a message that is only one or two characters long is received, the FIFO is not full so that ISR[1] does not set and the CPU is not interrupted. The CPU will not know that there is data in the receive FIFO. The timeout mode provides the user with a timeout interrupt via the C/T. If a character is received and the FIFO does not become full, a pre-selected period of delay can be timed out by the C/T and the CPU interrupted.

This mode is enabled by writing the appropriate command to the command register. Writing an "AX" to CRA or CRB will invoke the timeout mode for that channel. Writing a "CX" to CRA or CRB will reset the timeout mode. CTU and CTL must be loaded with a value greater than the normal receive character period. Each time a received character is transferred from the shift register to the RHR, the C/T is reloaded with the value in CTU and CTL and then restarted. If the C/T is allowed to end the count, the counter ready bit (ISR[3]) will be set. If IMR[3] is set, an interrupt will occur.

### Multidrop Mode

The DUART is equipped with a wake up mode used for multidrop applications. This mode is selected by programming bits MR1A[4:3] or MR1B[4:3] to '11' for channels A and B, respectively. In this mode of operation, a "master" station transmits an address character followed by data characters for the addressed "slave" station. The slave stations, with receivers that are normally disabled, examine the received data stream and "wake-up" the CPU (by setting RxRDY) only upon receipt of an address character. The CPU compares the received address to its station address and enables the receiver if it wishes to receive the subsequent data characters. Upon receipt of another address character, the CPU may disable the receiver to initiate the process again.

A transmitted character consists of a start bit, the programmed number of data bits, an address/data (A/D) bit, and the programmed number of stop bits. The polarity of the transmitted A/D bit is selected by the CPU by programming bit MR1A[2]/MR1B[2]. MR1A[2]/MR1B[2] = 0 transmits a zero in the A/D bit position, which identifies the corresponding data bits as data, while MR1A[2]/MR1B[2] = 1 transmits a one in the A/D bit position, which identifies the corresponding data bits as an address. The CPU should program the mode register prior to loading the corresponding data bits into the THR.



## Dual Asynchronous Receiver/Transmitter (DUART)

SCC2692

Table 1. 2692 Register Addressing

A3	A2	A1	A0	READ (RDN = 0)	WRITE (WRN = 0)
0	0	0	0	Mode Register A (MR1A, MR2A)	Mode Register A (MR1A, MR2A)
0	0	0	1	Status Register A (SRA)	Clock Select Reg. A (CSRA)
0	0	1	0	*Reserved*	Command Register A (CRA)
0	0	1	1	Rx Holding Register A (RHRA)	Tx Holding Register A (THRA)
0	1	0	0	Input Port Change Reg. (IPCR)	Aux. Control Register (ACR)
0	1	0	1	Interrupt Status Reg. (ISR)	Interrupt Mask Reg. (IMR)
0	1	1	0	Counter/Timer Upper (CTU)	C/T Upper Register (CTUR)
0	1	1	1	Counter/Timer Lower (CTL)	C/T Lower Register (CTLR)
1	0	0	0	Mode Register B (MR1B, MR2B)	Mode Register B (MR1B, MR2B)
1	0	0	1	Status Register B (SRB)	Clock Select Reg. B (CSRB)
1	0	1	0	*Reserved*	Command Register B (CRB)
1	0	1	1	Rx Holding Register B (RHRB)	Tx Holding Register B (THRB)
1	1	0	0	*Reserved*	*Reserved*
1	1	0	1	Input Port	Output Port Conf. Reg. (OPCR)
1	1	1	0	Start Counter Command	Set Output Port Bits Command
1	1	1	1	Stop Counter Command	Reset Output Port Bits Command

In this mode, the receiver continuously looks at the received data stream, whether it is enabled or disabled. If disabled, it sets the RxRDY status bit and loads the character into the RHR FIFO if the received A/D bit is a one (address tag), but discards the received character if the received A/D bit is a zero (data tag). If enabled, all received characters are transferred to the CPU via the RHR. In either case, the data bits are loaded into the data FIFO while the A/D bit is loaded into the status FIFO position normally used for parity error (SRA[5] or SRB[5]). Framing error, overrun error, and break detect operate normally whether or not the receiver is enabled.

## PROGRAMMING

The operation of the DUART is programmed by writing control words into the appropriate registers. Operational feedback is provided via status registers which can be read by the CPU. The addressing of the registers is described in Table 1.

The contents of certain control registers are initialized to zero on RESET. Care should be exercised if the contents of a register are changed during operation, since certain changes may cause operational problems.

For example, changing the number of bits per character while the transmitter is active may cause the transmission of an incorrect character. In general, the contents of the MR, the CSR, and the OPCR should only be changed while the receiver(s) and transmitter(s) are not enabled, and certain changes to the ACR

should only be made while the C/T is stopped.

Mode registers 1 and 2 of each channel are accessed via independent auxiliary pointers. The pointer is set to MR1x by RESET or by issuing a 'reset pointer' command via the corresponding command register. Any read or write of the mode register while the pointer is at MR1x, switches the pointer to MR2x. The pointer then remains at MR2x, so that subsequent accesses are always to MR2x unless the pointer is reset to MR1x as described above.

Mode, command, clock select, and status registers are duplicated for each channel to provide total independent operation and control. Refer to Table 2 for register bit descriptions. The reserved registers at addresses H'02' and H'0A' should never be read during normal operation since they are reserved for internal diagnostics.

### MR1A — Channel A Mode Register 1

MR1A is accessed when the channel A MR pointer points to MR1. The pointer is set to MR1 by RESET or by a 'set pointer' command applied via CRA. After reading or writing MR1A, the pointer will point to MR2A.

### MR1A[7] — Channel A Receiver Request-to-Send Control

This bit controls the deactivation of the RTSAN output (OP0) by the receiver. This output is normally asserted by setting OPR[0] and negated by resetting OPR[0]. MR

1A[7] = 1 causes RTSAN to be negated upon receipt of a valid start bit if the channel A FIFO is full. However, OPR[0] is not reset and RTSAN will be asserted again when an empty FIFO position is available. This feature can be used for flow control to prevent overrun in the receiver by using the RTSAN output signal to control the CTSN input of the transmitting device.

### MR1A[6] — Channel A Receiver Interrupt Select

This bit selects either the channel A receiver ready status (RxRDY) or the channel A FIFO full status (FFULL) to be used for CPU interrupts. It also causes the selected bit to be output on OP4 if it is programmed as an interrupt output via the OPCR.

**MR1A[5] — Channel A Error Mode Select**  
This bit selects the operating mode of the three FIFOed status bits (FE, PE, received break) for channel A. In the 'character' mode, status is provided on a character-by-character basis; the status applies only to the character at the top of the FIFO. In the 'block' mode, the status provided in the SR for these bits is the accumulation (logical-OR) of the status for all characters coming to the top of the FIFO since the last 'reset error' command for channel A was issued.

### MR1A[4:3] — Channel A Parity Mode Select

If 'with parity' or 'force parity' is selected, a parity bit is added to the transmitted character and the receiver performs a parity check on incoming data. MR1A[4:3] = 11 selects channel A to operate in the special multidrop mode described in the Operation section.

### MR1A[2] — Channel A Parity Type Select

This bit selects the parity type (odd or even) if the 'with parity' mode is programmed by MR1A[4:3], and the polarity of the forced parity bit if the 'force parity' mode is programmed. It has no effect if the 'no parity' mode is programmed. In the special multidrop mode it selects the polarity of the A/D bit.

### MR1A[1:0] — Channel A Bits Per Character Select

This field selects the number of data bits per character to be transmitted and received. The character length does not include the start, parity, and stop bits.

Table 2. Register Bit Formats

	BIT 7	BIT 6	BIT 5	BIT 4	BIT 3	BIT 2	BIT 1	BIT 0
	<b>RxRTS CONTROL</b>	<b>RxINT SELECT</b>	<b>ERROR MODE</b>	<b>PARITY MODE</b>	<b>PARITY TYPE</b>	<b>PARITY TYPE</b>	<b>BITS PER CHARACTER</b>	
<b>MR1A</b>	0 = no	0 = RxRDY	0 = char	00 = with parity	0 = even		00 = 5	
<b>MR1B</b>	1 = yes	1 = FFULL	1 = block	01 = force parity	1 = odd		01 = 6	
				10 = no parity			10 = 7	
				11 = multi-drop mode			11 = 8	

# Dual Asynchronous Receiver/Transmitter (DUART)

SCC2692

Table 2. Register Bit Formats (Continued)

	BIT 7	BIT 6	BIT 5	BIT 4	BIT 3	BIT 2	BIT 1	BIT 0
	<b>CHANNEL MODE</b>		<b>TxRTS CONTROL</b>	<b>CTS ENABLE Tx</b>	<b>STOP BIT LENGTH*</b>			
MR2A MR2B	00 = Normal 01 = Auto-echo 10 = Local loop 11 = Remote loop		0 = no 1 = yes	0 = no 1 = yes	0 = 0.563 1 = 0.625 2 = 0.688 3 = 0.750	4 = 0.813 5 = 0.875 6 = 0.938 7 = 1.000	8 = 1.563 9 = 1.625 A = 1.688 B = 1.750	C = 1.813 D = 1.875 E = 1.938 F = 2.000

**NOTE:**

\*Add 0.5 to values shown for 0-7 if channel is programmed for 5 bits/char.

	BIT 7	BIT 6	BIT 5	BIT 4	BIT 3	BIT 2	BIT 1	BIT 0
	<b>RECEIVER CLOCK SELECT</b>				<b>TRANSMITTER CLOCK SELECT</b>			
CSRA CSRB	See Text				See Text			

	BIT 7	BIT 6	BIT 5	BIT 4	BIT 3	BIT 2	BIT 1	BIT 0
	<b>MISCELLANEOUS COMMANDS</b>				<b>DISABLE Tx</b>	<b>ENABLE Tx</b>	<b>DISABLE Rx</b>	<b>ENABLE Rx</b>
CRA CRB	See Text				0 = no 1 = yes	0 = no 1 = yes	0 = no 1 = yes	0 = no 1 = yes

	BIT 7	BIT 6	BIT 5	BIT 4	BIT 3	BIT 2	BIT 1	BIT 0
	<b>RECEIVED BREAK</b>	<b>FRAMING ERROR</b>	<b>PARITY ERROR</b>	<b>OVERRUN ERROR</b>	<b>TxE<sub>MT</sub></b>	<b>TxRDY</b>	<b>FFULL</b>	<b>RxRDY</b>
SRA SRB	0 = no 1 = yes *	0 = no 1 = yes *	0 = no 1 = yes *	0 = no 1 = yes	0 = no 1 = yes	0 = no 1 = yes	0 = no 1 = yes	0 = no 1 = yes

**NOTE:**

\*These status bits are appended to the corresponding data character in the receive FIFO. A read of the status register provides these bits (7:5) from the top of the FIFO together with bits (4:0). These bits are cleared by a 'reset error status' command. In character mode they are discarded when the corresponding data character is read from the FIFO.

	BIT 7	BIT 6	BIT 5	BIT 4	BIT 3	BIT 2	BIT 1	BIT 0
	<b>OP7</b>	<b>OP6</b>	<b>OP5</b>	<b>OP4</b>	<b>OP3</b>		<b>OP2</b>	
OPCR	0 = OPR[7] 1 = TxRDYB	0 = OPR[6] 1 = TxRDYA	0 = OPR[5] 1 = RxRDY/ FFULLB	0 = OPR[4] 1 = RxRDY/ FFULLA	00 = OPR[3] 01 = C/T OUTPUT 10 = TxCB(1×) 11 = RxCB(1×)		00 = OPR[2] 01 = TxCA(16×) 10 = TxCA(1×) 11 = RxCA(1×)	

	BIT 7	BIT 6	BIT 5	BIT 4	BIT 3	BIT 2	BIT 1	BIT 0
	<b>BRG SET SELECT</b>	<b>COUNTER/TIMER MODE AND SOURCE</b>			<b>DELTA IP3 INT</b>	<b>DELTA IP2 INT</b>	<b>DELTA IP1 INT</b>	<b>DELTA IP0 INT</b>
ACR	0 = set1 1 = set2	See Table 4			0 = off 1 = on	0 = off 1 = on	0 = off 1 = on	0 = off 1 = on

	BIT 7	BIT 6	BIT 5	BIT 4	BIT 3	BIT 2	BIT 1	BIT 0
	<b>DELTA IP3</b>	<b>DELTA IP2</b>	<b>DELTA IP1</b>	<b>DELTA IP0</b>	<b>IP3</b>	<b>IP2</b>	<b>IP1</b>	<b>IP0</b>
IPCR	0 = no 1 = yes	0 = no 1 = yes	0 = no 1 = yes	0 = no 1 = yes	0 = low 1 = high	0 = low 1 = high	0 = low 1 = high	0 = low 1 = high

	BIT 7	BIT 6	BIT 5	BIT 4	BIT 3	BIT 2	BIT 1	BIT 0
	<b>INPUT PORT CHANGE</b>	<b>DELTA BREAK B</b>	<b>RxRDY/FFULLB</b>	<b>TxRDYB</b>	<b>COUNTER READY</b>	<b>DELTA BREAK A</b>	<b>RxRDY/FFULLA</b>	<b>TxRDYA</b>
ISR	0 = no 1 = yes	0 = no 1 = yes	0 = no 1 = yes	0 = no 1 = yes	0 = no 1 = yes	0 = no 1 = yes	0 = no 1 = yes	0 = no 1 = yes

## Dual Asynchronous Receiver/Transmitter (DUART)

SCC2692

2

Table 2. Register Bit Formats (Continued)

	BIT 7	BIT 6	BIT 5	BIT 4	BIT 3	BIT 2	BIT 1	BIT 0
IMR	IN. PORT CHANGE INT	DELTA BREAK B INT	RxRDY/ FFULLB INT	TxRDYB INT	COUNTER READY INT	DELTA BREAK A INT	RxRDY/ FFULLA INT	TxRDYA INT
	0 = off 1 = on	0 = off 1 = on	0 = off 1 = on	0 = off 1 = on	0 = off 1 = on	0 = off 1 = on	0 = off 1 = on	0 = off 1 = on
CTUR	C/T[15]	C/T[14]	C/T[13]	C/T[12]	C/T[11]	C/T[10]	C/T[9]	C/T[8]
CTLR	C/T[7]	C/T[6]	C/T[5]	C/T[4]	C/T[3]	C/T[2]	C/T[1]	C/T[0]

**MR2A — Channel A Mode Register 2**

MR2A is accessed when the channel A MR pointer points to MR2, which occurs after any access to MR1A. Accesses to MR2A do not change the pointer.

**MR2A[7:6] — Channel A Mode Select**

Each channel of the DUART can operate in one of four modes. MR2A[7:6] = 00 is the normal mode, with the transmitter and receiver operating independently. MR2A[7:6] = 01 places the channel in the automatic echo mode, which automatically retransmits the received data. The following conditions are true while in automatic echo mode:

1. Received data is relocked and retransmitted on the TxDA output.
2. The receive clock is used for the transmitter.
3. The receiver must be enabled, but the transmitter need not be enabled.
4. The channel A TxRDY and TxEMT status bits are inactive.
5. The received parity is checked, but is not regenerated for transmission; i.e., transmitted parity bit is as received.
6. Character framing is checked, but the stop bits are retransmitted as received.
7. A received break is echoed as received until the next valid start bit is detected.
8. CPU to receiver communication continues normally, but the CPU to transmitter link is disabled.

Two diagnostic modes can also be configured. MR2A[7:6] = 10 selects local loopback mode. In this mode:

1. The transmitter output is internally connected to the receiver input.
2. The transmit clock is used for the receiver.
3. The TxDA output is held high.
4. The RxDA input is ignored.
5. The transmitter must be enabled, but the receiver need not be enabled.
6. CPU to transmitter and receiver communications continue normally.

The second diagnostic mode is the remote loopback mode, selected by MR2A[7:6] = 11. In this mode:

1. Received data is relocked and retransmitted on the TxDA output.
2. The receive clock is used for the transmitter.
3. Received data is not sent to the local CPU, and the error status conditions are inactive.
4. The received parity is not checked and is not regenerated for transmission, i.e., transmitted parity bit is as received.
5. The receiver must be enabled.
6. Character framing is not checked, and the stop bits are retransmitted as received.
7. A received break is echoed as received until the next valid start bit is detected.

The user must exercise care when switching into and out of the various modes. The selected mode will be activated immediately upon mode selection, even if this occurs in the middle of a received or transmitted character. Likewise, if a mode is deselected, the

device will switch out of the mode immediately. An exception to this is switching out of autoecho or remote loopback modes; if the de-selection occurs just after the receiver has sampled the stop bit (indicated in autoecho by assertion of RxRDY), and the transmitter is enabled, the transmitter will remain in autoecho mode until the entire stop bit has been retransmitted.

**MR2A[5] — Channel A Transmitter Request-to-Send Control**

This bit controls the deactivation of the RTSAN output (OP0) by the transmitter. This output is normally asserted by setting OPR[0] and negated by resetting OPR[0]. MR 2A[5] = 1 causes OPR[0] to be reset automatically one bit time after the characters in the channel A transmit shift register and in the THR, if any, are completely transmitted, including the programmed number of stop bits, if the transmitter is not enabled. This feature can be used to automatically terminate the transmission of a message as follows:

1. Program auto-reset mode: MR2A[5] = 1.
2. Enable transmitter.
3. Assert RTSAN: OPR[0] = 1.
4. Send message.
5. Verify the message is sent by waiting until the transmit ready status (TxRDY) is asserted. Disable transmitter after the last character is loaded into the channel A THR.
6. The last character will be transmitted and OPR[0] will be reset one bit time after the last stop bit, causing RTSAN to be negated.

## Dual Asynchronous Receiver/Transmitter (DUART)

SCC2692

**MR2A[4] — Channel A Clear-to-send Control**

If this bit is 0, CTSAN has no effect on the transmitter. If this bit is a 1, the transmitter checks the state of CTSAN (IP0) each time it is ready to send a character. If IP0 is asserted (low), the character is transmitted. If it is negated (high), the TxDA output remains in the marking state and the transmission is delayed until CTSAN goes low. Changes in CTSAN while a character is being transmitted do not affect the transmission of that character.

**MR2A[3:0] — Channel A Stop Bit Length Select**

This field programs the length of the stop bit appended to the transmitted character. Stop bit lengths of  $\frac{9}{16}$  to 1 and  $1\frac{7}{16}$  to 2 bits, in increments of  $\frac{1}{16}$  bit, can be programmed for character lengths of 6, 7, and 8 bits. For a character length of 5 bits,  $1\frac{1}{16}$  to 2 stop bits can be programmed in increments of  $\frac{1}{16}$ -bit. The receiver only checks for a 'mark' condition at the center of the first stop bit position (one bit time after the last data bit, or after the parity bit if parity is enabled) in all cases.

If an external  $1\times$  clock is used for the transmitter, MR2A[3] = 0 selects one stop bit and MR2A[3] = 1 selects two stop bits to be transmitted.

**MR1B — Channel B Mode Register 1**

MR1B is accessed when the channel B MR pointer points to MR1. The pointer is set to MR1 by RESET or by a 'set pointer' command applied via CRB. After reading or writing MR1B, the pointer will point to MR2B.

The bit definitions for this register are identical to the bit definitions for MR1A, except that all control actions apply to the channel B receiver and transmitter and the corresponding inputs and outputs.

**MR2B — Channel B Mode Register 2**

MR2B is accessed when the channel B MR pointer points to MR2, which occurs after any access to MR1B. Accesses to MR2B do not change the pointer.

The bit definitions for this register are identical to the bit definitions for MR2A, except that all control actions apply to the channel B receiver and transmitter and the corresponding inputs and outputs.

**CSRA — Channel A Clock Select Register****CSRA[7:4] — Channel A Receiver Clock Select**

This field selects the baud rate clock for the channel A receiver as follows:

CSRA[7:4]	Baud Rate	
	ACR[7] = 0	ACR[7] = 1
0 0 0 0	50	75
0 0 0 1	110	110
0 0 1 0	134.5	134.5
0 0 1 1	200	150
0 1 0 0	300	300
0 1 0 1	600	600
0 1 1 0	1,200	1,200
0 1 1 1	1,050	2,000
1 0 0 0	2,400	2,400
1 0 0 1	4,800	4,800
1 0 1 0	7,200	1,800
1 0 1 1	9,600	9,600
1 1 0 0	38.4k	19.2k
1 1 0 1	Timer	Timer
1 1 1 0	IP4 — $16\times$	IP4 — $16\times$
1 1 1 1	IP4 — $1\times$	IP4 — $1\times$

The receiver clock is always a  $16\times$  clock except for CSRA[7:4] = 1111.

**CSRA[3:0] — Channel A Transmitter Clock Select**

This field selects the baud rate clock for the channel A transmitter. The field definition is as per CSRA[7:4] except as follows:

CSRA[3:0]	Baud Rate	
	ACR[7] = 0	ACR[7] = 1
1 1 1 0	IP3 — $16\times$	IP3 — $16\times$
0 1 1 1	IP3 — $1\times$	IP3 — $1\times$

The transmitter clock is always a  $16\times$  clock except for CSRA[3:0] = 1111.

**CSRB — Channel B Clock Select Register****CSRB[7:4] — Channel B Receiver Clock Select**

This field selects the baud rate clock for the channel B receiver. The field definition is as per CSRA[7:4] except as follows:

CSRB[7:4]	Baud Rate	
	ACR[7] = 0	ACR[7] = 1
1 1 1 0	IP6 — $16\times$	IP6 — $16\times$
0 1 1 1	IP6 — $1\times$	IP6 — $1\times$

The receiver clock is always a  $16\times$  clock except for CSRB[7:4] = 1111.

**CSRB[3:0] — Channel B Transmitter Clock Select**

This field selects the baud rate clock for the channel B transmitter. The field definition is as per CSRA[7:4] except as follows:

CSRB[3:4]	Baud Rate	
	ACR[7] = 0	ACR[7] = 1
1 1 1 0	IP5 — $16\times$	IP5 — $16\times$
1 1 1 1	IP5 — $1\times$	IP5 — $1\times$

The transmitter clock is always a  $16\times$  clock except for CSRB[3:0] = 1111.

**CRA — Channel A Command Register**

CRA is a register used to supply commands to channel A. Multiple commands can be specified in a single write to CRA as long as the commands are non-conflicting, e.g., the 'enable transmitter' and 'reset transmitter' commands cannot be specified in a single command word.

**CRA[6:4] — Channel A Miscellaneous Commands**

The encoded value of this field may be used to specify a single command as follows:

CRA[7:4]	COMMAND
0 0 0 0	No command.
0 0 0 1	Reset MR pointer. Causes the channel A MR pointer to point to MR1.
0 0 1 0	Reset receiver. Resets the channel A receiver as if a hardware reset had been applied. The receiver is disabled and the FIFO is flushed.
0 0 1 1	Reset transmitter. Resets the channel A transmitter as if a hardware reset had been applied.
0 1 0 0	Reset error status. Clears the channel A Received Break, Parity Error, Framing Error, and Overrun Error bits in the status register (SRA[7:4]). Used in character mode to clear OE status (although RB, PE, and FE bits will also be cleared) and in block mode to clear all error status after a block of data has been received.
0 1 0 1	Reset channel A break change interrupt. Causes the channel A break detect change bit in the interrupt status register (ISR[2]) to be cleared to zero.
0 1 1 0	Start break. Forces the TxDA output low (spacing). If the transmitter is empty the start of the break condition will be delayed up to two bit times. If the transmitter is active the break begins when transmission of the character is completed. If a character is in the THR, the start of the break will be delayed until that character, or any others loaded subsequently are transmitted. The transmitter must be enabled for this command to be accepted.

## Dual Asynchronous Receiver/Transmitter (DUART)

SCC2692

2

CRA[7:4]	COMMAND
0 1 1 1	Stop Break. The TxDA line will go high (marking) within two bit times. TxDA will remain high for one bit time before the next character, if any, is transmitted.
1 0 0 0	Assert RTSN. Causes the RTSN output to be asserted (low).
1 0 0 1	Negate RTSN. Causes the RTSN output to be negated (high).
1 0 1 0	Set special timeout mode on with this channel as the channel to restart the C/T as each receive character is transferred from the serial shift register to the RHR.
1 0 1 1	Not used.
1 1 0 0	Reset special timeout mode.
1 1 0 1	Not used.
1 1 1 0	Power Down mode on. In this mode, the DUART oscillator is stopped and all functions requiring this clock are suspended. The contents of all registers are saved. It is recommended that the transmitter and receiver be disabled prior to placing the DUART in this mode. This bit is reset with the assertion of RESET. This command is in CRA only.
1 1 1 1	Power Down Mode Normal Run. This command resets the Power Down mode. This command is in CRA only.

**CRA[3] — Disable Channel A Transmitter**  
This command terminates transmitter operation and resets the TxRDY and TxEMT status bits. However, if a character is being transmitted or if a character is in the THR when the transmitter is disabled, the transmission of the character(s) is completed before assuming the inactive state.

**CRA[2] — Enable Channel A Transmitter**  
Enables operation of the channel A transmitter. The TxRDY status bit will be asserted.

**CRA[1] — Disable Channel A Receiver**  
This command terminates operation of the receiver immediately — a character being received will be lost. The command has no effect on the receiver status bits or any other control registers. If the special multidrop mode is programmed, the receiver operates even if it is disabled. See Operation section.

**CRA[0] — Enable Channel A Receiver**  
Enables operation of the channel A receiver. If not in the special wakeup mode, this also forces the receiver into the search for start-bit state.

### CRB — Channel B Command Register

CRB is a register used to supply commands to channel B. Multiple commands can be specified in a single write to CRB as long as

the commands are non-conflicting, e.g., the 'enable transmitter' and 'reset transmitter' commands cannot be specified in a single command word.

The bit definitions for this register are identical to the bit definitions for CRA with the exceptions of the last two command "EX" and "FX" which are used for power down mode. These two commands are not used in CRB. All other control actions that apply to CRA also apply to CRB.

### SRA — Channel A Status Register

#### SRA[7] — Channel A Received Break

This bit indicates that an all zero character of the programmed length has been received without a stop bit. Only a single FIFO position is occupied when a break is received; further entries to the FIFO are inhibited until the RxDA line returns to the marking state for at least one-half a bit time (two successive edges of the internal or external  $1 \times$  clock).

When this bit is set, the channel A 'change in break' bit in the ISR (ISR[2]) is set. ISR[2] is also set when the end of the break condition, as defined above, is detected.

The break detect circuitry can detect breaks that originate in the middle of a received character. However, if a break begins in the middle of a character, it must persist until at least the end of the next character time in order for it to be detected.

#### SRA[6] — Channel A Framing Error

This bit, when set, indicates that a stop bit was not detected when the corresponding data character in the FIFO was received. The stop bit check is made in the middle of the first stop bit position.

#### SRA[5] — Channel A Parity Error

This bit is set when the 'with parity' or 'force parity' mode is programmed and the corresponding character in the FIFO was received with incorrect parity.

In the special multidrop mode the parity error bit stores the received A/D bit.

#### SRA[4] — Channel A Overrun Error

This bit, when set, indicates that one or more characters in the received data stream have been lost. It is set-upon receipt of a new character when the FIFO is full and a character is already in the receive shift register waiting for an empty FIFO position. When this occurs, the character in the receive shift register (and its break detect, parity error and framing error status, if any) is lost.

This bit is cleared by a 'reset error status' command.

#### SRA[3] — Channel A Transmitter Empty (TxEMTA)

This bit will be set when the channel A transmitter underruns; i.e., both the transmit holding register (THR) and the transmit shift register are empty. It is set after transmission of the last stop bit of a character if no character is in the THR awaiting transmission. It is reset when the THR is loaded by the CPU or when the transmitter is disabled.

#### SRA[2] — Channel A Transmitter Ready (TxRDYA)

This bit, when set, indicates that the THR is empty and ready to be loaded with a character. This bit is cleared when the THR is loaded by the CPU and is set when the character is transferred to the transmit shift register. TxRDY is reset when the transmitter is disabled and is set when the transmitter is first enabled, viz., characters loaded into the THR while the transmitter is disabled will not be transmitted.

#### SRA[1] — Channel A FIFO Full (FFULLA)

This bit is set when a character is transferred from the receive shift register to the receive FIFO and the transfer causes the FIFO to become full, i.e., all three FIFO positions are occupied. It is reset when the CPU reads the RHR. If a character is waiting in the receive shift register because the FIFO is full, FFULL will not be reset when the CPU reads the RHR.

#### SRA[0] — Channel A Receiver Ready (RxRDYA)

This bit indicates that a character has been received and is waiting in the FIFO to be read by the CPU. It is set when the character is transferred from the receive shift register to the FIFO and reset when the CPU reads the RHR, only if (after this read) there are no more characters in the FIFO.

### SRB — Channel B Status Register

The bit definitions for this register are identical to the bit definitions for SRA, except that all status applies to the channel B receiver and transmitter and the corresponding inputs and outputs.

### OPCR — Output Port Configuration Register

#### OPCR[7] — OP7 Output Select

This bit programs the OP7 output to provide one of the following:

—The complement of OPR[7]

—The channel B transmitter interrupt output, which is the complement of TxRDYB. When in this mode OP7 acts as an open-drain output. Note that this output is not masked by the contents of the IMR.

## Dual Asynchronous Receiver/Transmitter (DUART)

SCC2692

**OPCR[6] — OP6 Output Select**

This bit programs the OP6 output to provide one of the following:

- The complement of OPR[6]
- The channel A transmitter interrupt output, which is the complement of TxRDYA. When in this mode OP6 acts as an open-drain output. Note that this output is not masked by the contents of the IMR.

**OPCR[5] — OP5 Output Select**

This bit programs the OP5 output to provide one of the following:

- The complement of OPR[5]
- The channel B receiver interrupt output, which is the complement of ISR[5]. When in this mode OP5 acts as an open-drain output. Note that this output is not masked by the contents of the IMR.

**OPCR[4] — OP4 Output Select**

This bit programs the OP4 output to provide one of the following:

- The complement of OPR[4]
- The channel A receiver interrupt output, which is the complement of ISR[1]. When in this mode OP4 acts as an open-drain output. Note that this output is not masked by the contents of the IMR.

**OPCR[3:2] — OP3 Output Select**

This field programs the OP3 output to provide one of the following:

- The complement of OPR[3]
- The counter/timer output, in which case OP3 acts as an open-drain output. In the timer mode, this output is a square wave at the programmed frequency. In the counter mode, the output remains high until terminal count is reached, at which time it goes low. The output returns to the high state when the counter is stopped by a stop counter command. Note that this output is not masked by the contents of the IMR.
- The  $1 \times$  clock for the channel B transmitter, which is the clock that shifts the transmitted data. If data is not being transmitted, a free running  $1 \times$  clock is output.
- The  $1 \times$  clock for the channel B receiver, which is the clock that samples the received data. If data is not being received, a free running  $1 \times$  clock is output.

**OPCR[1:0] — OP2 Output Select**

This field programs the OP2 output to provide one of the following:

- The complement of OPR[2]
- The  $16 \times$  clock for the channel A transmitter. This is the clock selected by CSRA[3:0], and will be a  $1 \times$  clock if CSRA[3:0] = 1111.

-The  $1 \times$  clock for the channel A transmitter, which is the clock that shifts the transmitted data. If data is not being transmitted, a free running  $1 \times$  clock is output.

-The  $1 \times$  clock for the channel A receiver, which is the clock that samples the received data. If data is not being received, a free running  $1 \times$  clock is output.

**ACR — Auxiliary Control Register****ACR[7] — Baud Rate Generator Set Select**

This bit selects one of two sets of baud rates to be generated by the BRG:

Set 1: 50, 110, 134.5, 200, 300, 600, 1.05k, 1.2k, 2.4k, 4.8k, 7.2k, 9.6k, and 38.4k baud.

Set 2: 75, 110, 134.5, 150, 300, 600, 1.2k, 1.8k, 2.0k, 2.4k, 4.8k, 9.6k, and 19.2k baud.

The selected set of rates is available for use by the channel A and B receivers and transmitters as described in CSRA and CSRB. Baud rate generator characteristics are given in Table 3.

**ACR[6:4] — Counter/Timer Mode And Clock Source Select**

This field selects the operating mode of the counter/timer and its clock source as shown in Table 4.

**ACR[3:0] — IP3, IP2, IP1, IP0 Change Of State Interrupt Enable**

This field selects which bits of the input port change register (IPCR) cause the input change bit in the interrupt status register (ISR[7]) to be set. If a bit is in the "on" state, the setting of the corresponding bit in the IPCR will also result in the setting of ISR[7], which results in the generation of an interrupt output if IMR[7] = 1. If a bit is in the "off" state, the setting of that bit in the IPCR has no effect on ISR[7].

**IPCR — Input Port Change Register****IPCR[7:4] — IP3, IP2, IP1, IP0 Change-of-State**

These bits are set when a change-of-state, as defined in the input port section of this data sheet, occurs at the respective input pins. They are cleared when the IPCR is read by the CPU. A read of the IPCR also clears ISR[7], the input change bit in the interrupt status register.

The setting of these bits can be programmed to generate an interrupt to the CPU.

**IPCR[3:0] — IP3, IP2, IP1, IP0 Current State**

These bits provide the current state of the respective inputs. The information is un-

latched and reflects the state of the input pins at the time the IPCR is read.

**ISR — Interrupt Status Register**

This register provides the status of all potential interrupt sources. The contents of this register are masked by the interrupt mask register (IMR). If a bit in the ISR is a '1' and the corresponding bit in the IMR is also a '1', the INTRN output will be asserted. If the corresponding bit in the IMR is a zero, the state of the bit in the ISR has no effect on the INTRN output. Note that the IMR does not mask the reading of the ISR — the true status will be provided regardless of the contents of the IMR. The contents of this register are initialized to 00<sub>16</sub> when the DUART is reset.

**ISR[7] — Input Port Change Status**

This bit is a '1' when a change of state has occurred at the IP0, IP1, IP2, or IP3 inputs and that event has been selected to cause an interrupt by the programming of ACR[3:0]. The bit is cleared when the CPU reads the IPCR.

**ISR[6] — Channel B Change In Break**

This bit, when set, indicates that the channel B receiver has detected the beginning or the end of a received break. It is reset when the CPU issues a channel B "reset break change interrupt" command.

**ISR[5] — Channel B Receiver Ready Or FIFO Full**

The function of this bit is programmed by MR1B[6]. If programmed as receiver ready, it indicates that a character has been received in channel B and is waiting in the FIFO to be read by the CPU. It is set when the character is transferred from the receive shift register to the FIFO and reset when the CPU reads the RHR. If after this read there are more characters still in the FIFO the bit will be set again after the FIFO is "popped". If programmed as FIFO full, it is set when a character is transferred from the receive holding register to the receive FIFO and the transfer causes the channel B FIFO to become full; i.e., all three FIFO positions are occupied. It is reset when the CPU reads the RHR. If a character is waiting in the receive shift register because the FIFO is full, the bit will be set again when the waiting character is loaded into the FIFO.

**ISR[4] — Channel B Transmitter Ready**

This bit is a duplicate of TxRDYB (SRB[2]).

**ISR[3] — Counter Ready**

In the counter mode, this bit is set when the counter reaches terminal count and is reset when the counter is stopped by a stop counter command.

In the timer mode, this bit is set once each cycle of the generated square wave (every other time that the counter/timer reaches zero count). The bit is reset by a stop counter

## Dual Asynchronous Receiver/Transmitter (DUART)

SCC2692

**Table 3. Baud Rate Generator Characteristics**  
Crystal or Clock = 3.6864MHz

NOMINAL RATE (BAUD)	ACTUAL 16× CLOCK (kHz)	ERROR (%)
50	0.8	0
75	1.2	0
110	1.759	-0.069
134.5	2.153	0.059
150	2.4	0
200	3.2	0
300	4.8	0
600	9.6	0
1050	16.756	-0.260
1200	19.2	0
1800	28.8	0
2000	32.056	0.175
2400	38.4	0
4800	76.8	0
7200	115.2	0
9600	153.6	0
19.2k	307.2	0
38.4k	614.4	0

**NOTE:**

Duty cycle of 16× clock is 50% ± 1%

**Table 4. ACR 6:4 Field Definition**

ACR 6:4	MODE	CLOCK SOURCE
0 0 0	Counter	External (IP2)
0 0 1	Counter	TxCA — 1× clock of channel A transmitter
0 1 0	Counter	TxCB — 1× clock of channel B transmitter
0 1 1	Counter	Crystal or external clock (X1/CLK) divided by 16
1 0 0	Timer	External (IP2)
1 0 1	Timer	External (IP2) divided by 16
1 1 0	Timer	Crystal or external clock (X1/CLK)
1 1 1	Timer	Crystal or external clock (X1/CLK) divided by 16

command. The command, however, does not stop the counter/timer.

**ISR[2] — Channel A Change In Break**

This bit, when set, indicates that the channel A receiver has detected the beginning or the end of a received break. It is reset when the CPU issues a channel A 'reset break change interrupt' command.

**ISR[1] — Channel A Receiver Ready Or FIFO Full**

The function of this bit is programmed by MR1A[6]. If programmed as receiver ready, it indicates that a character has been received in channel A and is waiting in the FIFO to be read by the CPU. It is set when the character is transferred from the receive shift register to the FIFO and reset when the CPU reads the RHR. If after this read there are more characters still in the FIFO the bit will be set again after the FIFO is 'popped'. If programmed as FIFO full, it is set when a character is transferred from the receive holding register to the receive FIFO and the transfer causes the channel A FIFO to become full, i.e., all three FIFO positions are occupied. It is reset when the CPU reads the RHR. If a character

is waiting in the receive shift register because the FIFO is full, the bit will be set again when the waiting character is loaded into the FIFO.

**ISR[0] — Channel A Transmitter Ready**  
This bit is a duplicate of TxRDYA (SRA[2]).

**IMR — Interrupt Mask Register**

The programming of this register selects which bits in the ISR cause an interrupt output. If a bit in the ISR is a '1' and the corresponding bit in the IMR is also a '1', the INTRN output will be asserted. If the corresponding bit in the IMR is a zero, the state of the bit in the ISR has no effect on the INTRN output. Note that the IMR does not mask the programmable interrupt outputs OP3 - OP7 or the reading of the ISR.

**CTUR and CTLR — Counter/Timer Registers**

The CTUR and CTLR hold the eight MSBs and eight LSBs, respectively, of the value to be used by the counter/timer in either the counter or timer modes of operation. The minimum value which may be loaded into the CTUR/CTLR registers is 0002<sub>16</sub>. Note that these registers are write-only and cannot be read by the CPU.

In the timer (programmable divider) mode, the C/T generates a square wave with a period of twice the value (in clock periods) of the CTUR and CTLR. If the value in CTUR or CTLR is changed, the current half-period will not be affected, but subsequent half periods will be. In this mode the C/T runs continuously. Receipt of a start counter command (read with A3 - A0 = 1110) causes the counter to terminate the current timing cycle and to begin a new cycle using the values in CTUR and CTLR.

The counter ready status bit (ISR[3]) is set once each cycle of the square wave. The bit is reset by a stop counter command (read with A3 - A0 = 1111). The command, however, does not stop the C/T. The generated square wave is output on OP3 if it is programmed to be the C/T output.

On power up and after reset, the timer/counter runs in timer mode and can only be restarted. Because it cannot be shut off or stopped, and runs continuously in timer mode, it is recommended that at initialization, the output port (OP3) should be masked off through the OPCR[3:2] = 00 until the T/C is programmed to the desired operational state.

In the counter mode, the C/T counts down the number of pulses loaded into CTUR and CTLR by the CPU. Counting begins upon receipt of a start counter command. Upon reaching terminal count (0000<sub>16</sub>), the counter ready interrupt bit (ISR[3]) is set. The counter continues counting past the terminal count until stopped by the CPU. If OP3 is programmed to be the output of the C/T, the output remains high until terminal count is reached, at which time it goes low. The output returns to the high state and ISR[3] is cleared when the counter is stopped by a stop counter command. The CPU may change the values of CTUR and CTLR at any time, but the new count becomes effective only on the next start counter command. If new values have not been loaded, the previous count values are preserved and used for the next count cycle.

In the counter mode, the current value of the upper and lower 8 bits of the counter (CTU, CTL) may be read by the CPU. It is recommended that the counter be stopped when reading to prevent potential problems which may occur if a carry from the lower 8 bits to the upper 8 bits occurs between the times that both halves of the counter are read. However, note that a subsequent start counter command will cause the counter to begin a new count cycle using the values in CTUR and CTLR.

## Dual Asynchronous Receiver/Transmitter (DUART)

SCC2692

ABSOLUTE MAXIMUM RATINGS<sup>1</sup>

SYMBOL	PARAMETER	RATING	UNIT
T <sub>A</sub>	Operating ambient temperature <sup>2</sup>	0 to +70	°C
T <sub>STG</sub>	Storage temperature	-65 to +150	°C
V <sub>CC</sub>	Voltage from V <sub>CC</sub> to GND <sup>3</sup>	-0.5 to +7	V
V <sub>S</sub>	Voltage from any pin to ground <sup>3</sup>	-0.5 to V <sub>CC</sub> ± 10%	V
P <sub>D</sub>	Power dissipation	21	mW

DC ELECTRICAL CHARACTERISTICS T<sub>A</sub> = 0°C to +70°C, V<sub>CC</sub> = +5.0V ± 5%<sup>4, 5, 6</sup>

SYMBOL	PARAMETER	TEST CONDITIONS	LIMITS			UNIT
			Min	Typ	Max	
V <sub>IL</sub> V <sub>IH</sub>	Input low voltage Input high voltage All except X1/CLK X1/CLK		2 0.9V <sub>CC</sub>		0.8 V <sub>CC</sub>	V V V
V <sub>OL</sub> V <sub>OH</sub> <sup>7</sup>	Output low voltage Output high voltage (except open drain outputs)	I <sub>OL</sub> = 2.4mA I <sub>OH</sub> = -400μA			0.4	V V
I <sub>IL</sub> I <sub>LL</sub> I <sub>OD</sub>	Input leakage current Data bus 3-State leakage current Open drain output leakage current	V <sub>IN</sub> = 0 to V <sub>CC</sub> V <sub>O</sub> = 0.4 to V <sub>CC</sub> V <sub>O</sub> = 0.4 to V <sub>CC</sub>	-10 -10 -10		10 10 10	μA μA μA
I <sub>X1L</sub> I <sub>X1H</sub>	X1/CLK low input current X1/CLK high input current	V <sub>IN</sub> = 0, X2 floated V <sub>IN</sub> = V <sub>CC</sub> , X2 floated	-100 0.0	-3.0 +30	0.0 100	μA μA
<b>When oscillator is in power-down mode:</b>						
I <sub>X1H</sub>	X1/CLK high input current	V <sub>IN</sub> = V <sub>CC</sub> , X2 floated	2	6	10	mA
I <sub>CC</sub>	Power supply current Standby			0.8	4 500	mA μA

## NOTES:

- Stresses above those listed under Absolute Maximum Ratings may cause permanent damage to the device. This is a stress rating only and functional operation of the device at these or any other condition above those indicated in the operation section of this specification is not implied.
- For operating at elevated temperatures, the device must be derated based on +150°C maximum junction temperature.
- This product includes circuitry specifically designed for the protection of its internal devices from damaging effects of excessive static charge. Nonetheless, it is suggested that conventional precautions be taken to avoid applying any voltages larger than the rated maxima.
- Parameters are valid over specified temperature range.
- All voltage measurements are referenced to ground (GND). For testing, all input signals swing between 0.4V and 2.4V with a transition time of 20ns maximum. For X1/CLK this swing is between 0.4V and 4.4V. All time measurements are referenced at input voltages of 0.8V and 2.0V and output voltages of 0.8V and 2.0V as appropriate.
- Typical values are at +25°C, typical supply voltages, and typical processing parameters.
- Test condition for outputs: C<sub>L</sub> = 150pF, except interrupt outputs. Test conditions for interrupt outputs: C<sub>L</sub> = 50pF, R<sub>L</sub> = 2.7kΩ to V<sub>CC</sub>.
- Timing is illustrated and referenced to the WRN and RDN inputs. The device may also be operated with CEN as the 'strobing' input. In this case, all timing specifications apply referenced to the falling and rising edges of CEN. CEN and RDN (also CEN and WRN) are OR'ed internally. As a consequence, the signal asserted last initiates the cycle and the signal negated first terminates the cycle.
- If CEN is used as the 'strobing' input, this parameter defines the minimum high time between one CEN and the next. The RDN signal must be negated for t<sub>RWD</sub> to guarantee that any status register changes are valid.
- Consecutive write operations to the same command require at least three edges of the X1 clock between writes.



## Dual Asynchronous Receiver/Transmitter (DUART)

SCC2692

**AC ELECTRICAL CHARACTERISTICS**  $T_A = 0^\circ\text{C}$  to  $+70^\circ\text{C}$ ,  $V_{CC} = +5.0\text{V} \pm 5\%$ <sup>4, 5, 6, 7</sup>

SYMBOL	PARAMETER	LIMITS			UNIT
		Min	Typ	Max	
<b>Reset timing (Figure 1)</b>					
$t_{RES}$	RESET pulse width	1.0			$\mu\text{s}$
<b>Bus timing (Figure 2)<sup>8</sup></b>					
$t_{AS}$	A0 - A3 setup time to RDN, WRN low	10			ns
$t_{AH}$	A0 - A3 hold time from RDN, WRN high	0			ns
$t_{CS}$	CEN setup time to RDN, WRN low	0			ns
$t_{CH}$	CEN hold time from RDN, WRN high	0			ns
$t_{RW}$	WRN, RDN pulse width	225			ns
$t_{DD}$	Data valid after RDN low			180	ns
$t_{DF}$	Data bus floating after RDN high			65	ns
$t_{DS}$	Data setup time before WRN high	100			ns
$t_{DH}$	Data hold time after WRN high	0			ns
$t_{RWD}$	High time between READS and/or WRITES <sup>9,10</sup>	200			ns
<b>Port timing (Figure 3)<sup>8</sup></b>					
$t_{PS}$	Port input setup time before RDN low	0			ns
$t_{PH}$	Port input hold time after RDN high	0			ns
$t_{PD}$	Port output valid after WRN high			370	ns
<b>Interrupt timing (Figure 4)</b>					
$t_{IR}$	INTRN (or OP3 - OP7 when used as interrupts) negated from: Read RHR (RxRDY/FFULL interrupt) Write THR (TxRDY interrupt) Reset command (delta break interrupt) Stop C/T command (counter interrupt) Read IPCR (input port change interrupt) Write IMR (clear of interrupt mask bit)			370 370 370 370 370 370	ns ns ns ns ns ns
<b>Clock timing (Figure 5)</b>					
$t_{CLK}$	X1/CLK high or low time	100			ns
$f_{CLK}$	X1/CLK frequency	2.0	3.6864	4	MHz
$t_{CTC}$	CTCLK (IP2) high or low time	100			ns
$f_{CTC}$	CTCLK (IP2) frequency	100		4M	Hz
$t_{RX}$	RxC high or low time	220			ns
$f_{RX}$	RxC frequency (16 $\times$ )	100		2M	Hz
	(1 $\times$ )	100		1M	Hz
$t_{TX}$	TxC high or low time	220			ns
$f_{TX}$	TxC frequency (16 $\times$ )	0		2	MHz
	(1 $\times$ )	0		1	MHz
<b>Transmitter timing (Figure 6)</b>					
$t_{TXD}$	TxD output delay from TxC low			350	ns
$t_{TCS}$	Output delay from TxC low to TxD data output	0		150	ns
<b>Receiver timing (Figure 7)</b>					
$t_{RXS}$	RxD data setup time to RxC high	240			ns
$t_{RXH}$	RxD data hold time from RxC high	200			ns

# Dual Asynchronous Receiver/Transmitter (DUART)

SCC2692

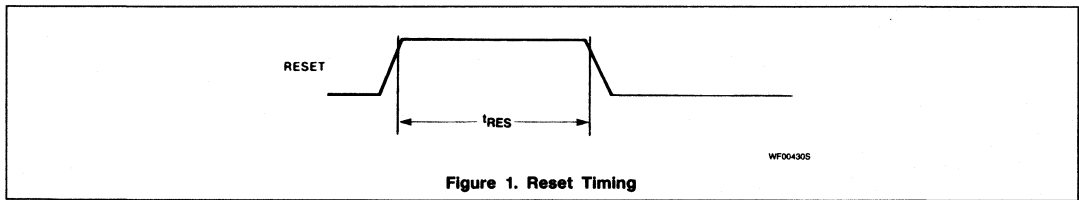

Figure 1. Reset Timing

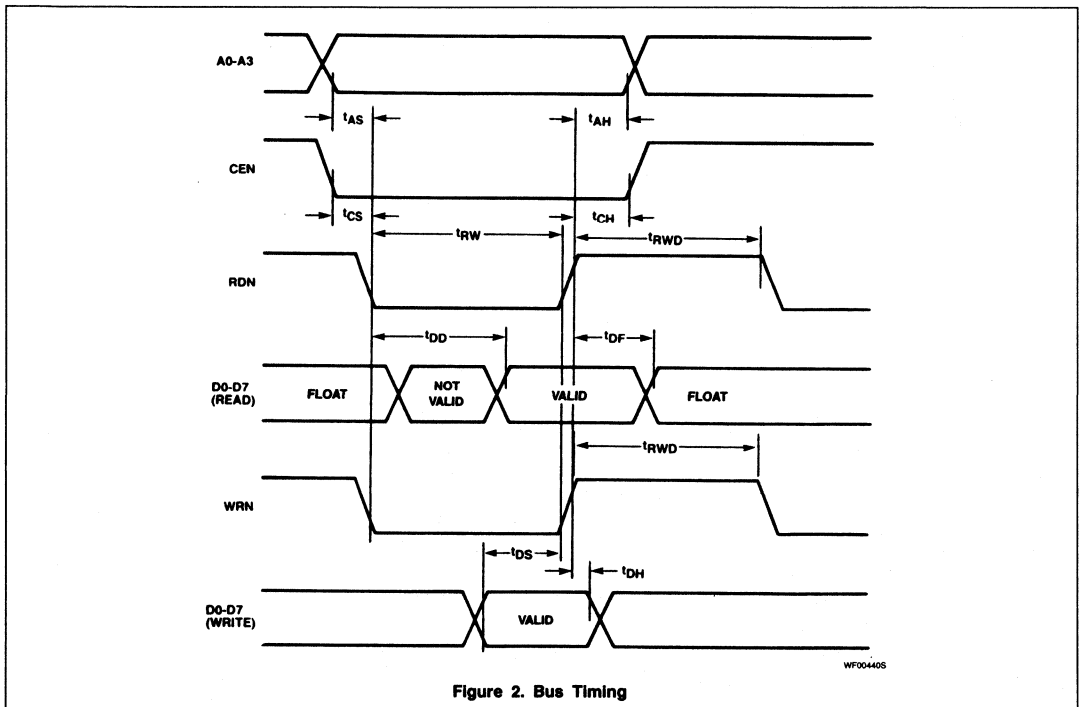
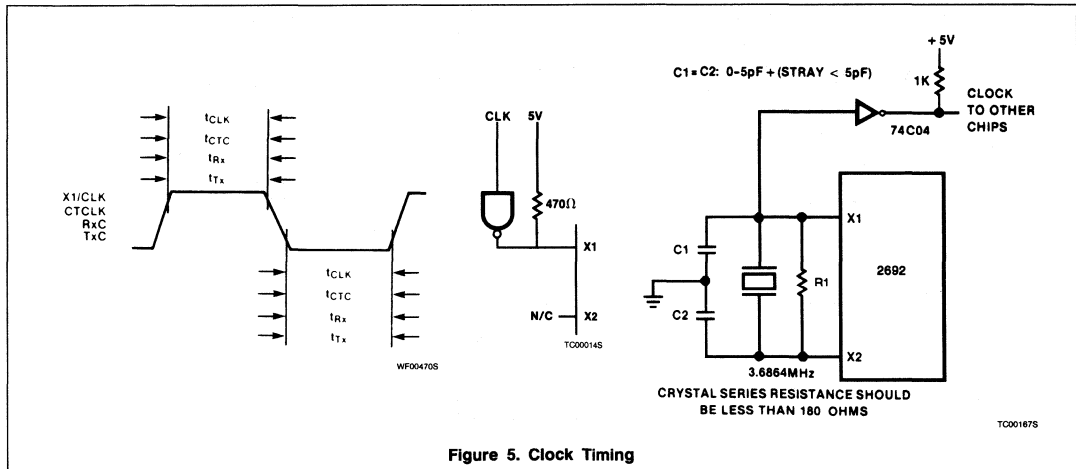
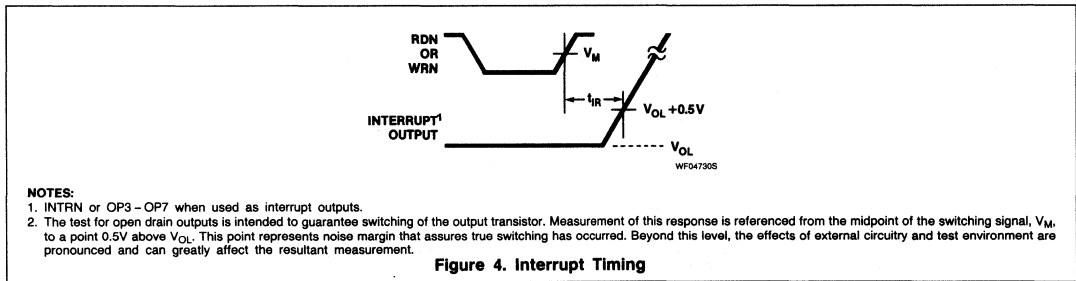
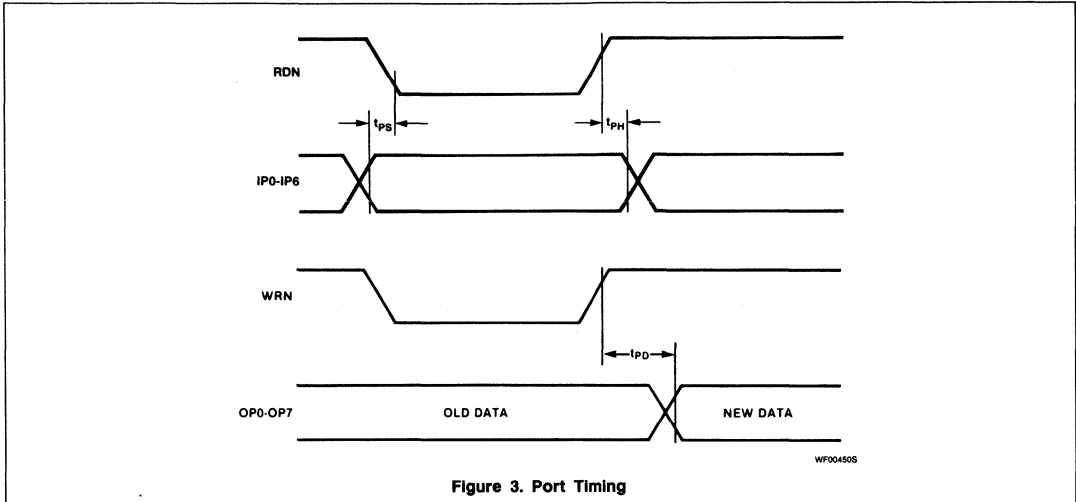

Figure 2. Bus Timing

# Dual Asynchronous Receiver/Transmitter (DUART)

SCC2692



# Dual Asynchronous Receiver/Transmitter (DUART)

SCC2692

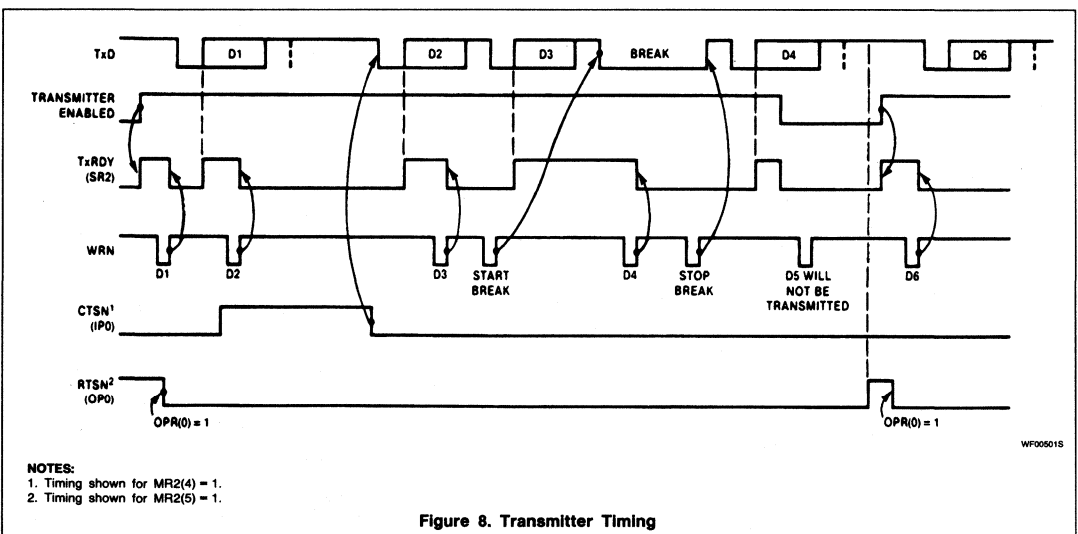
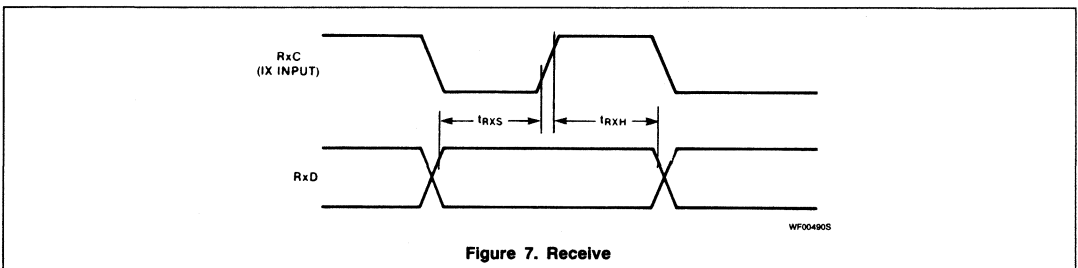
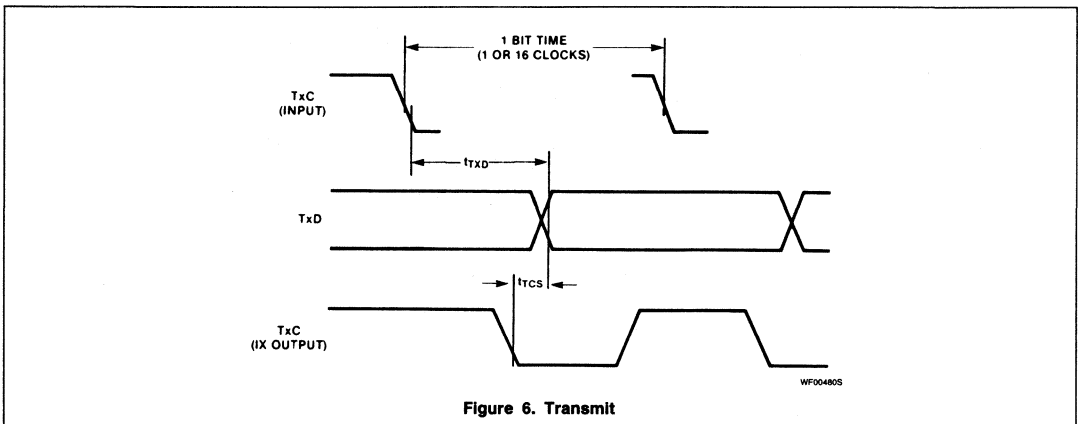

- NOTES:  
 1. Timing shown for MR2(4) = 1.  
 2. Timing shown for MR2(5) = 1.

# Dual Asynchronous Receiver/Transmitter (DUART)

SCC2692

2

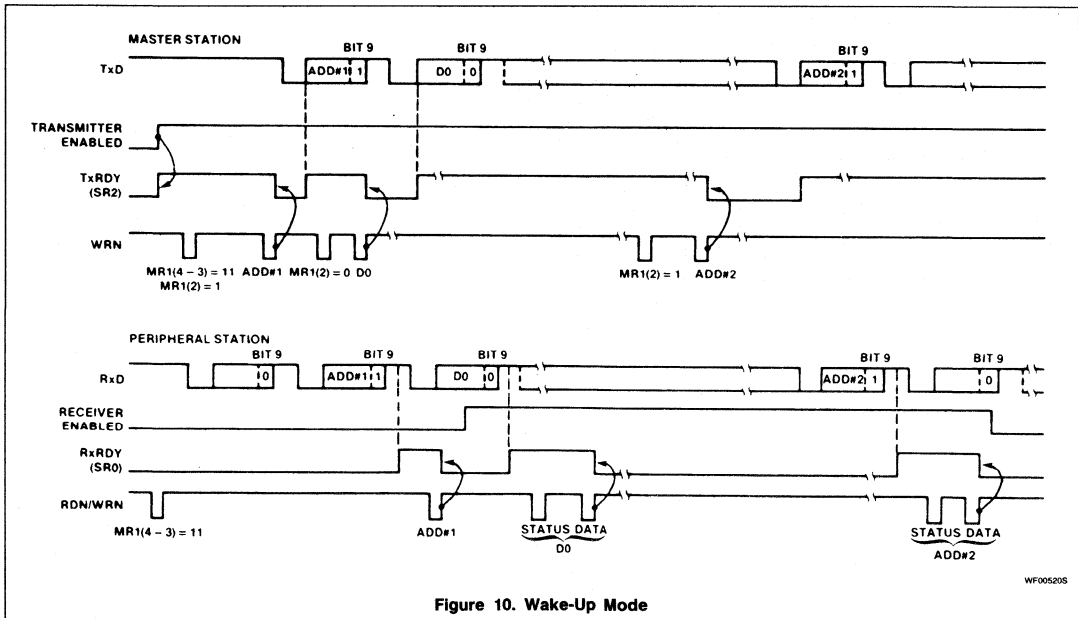
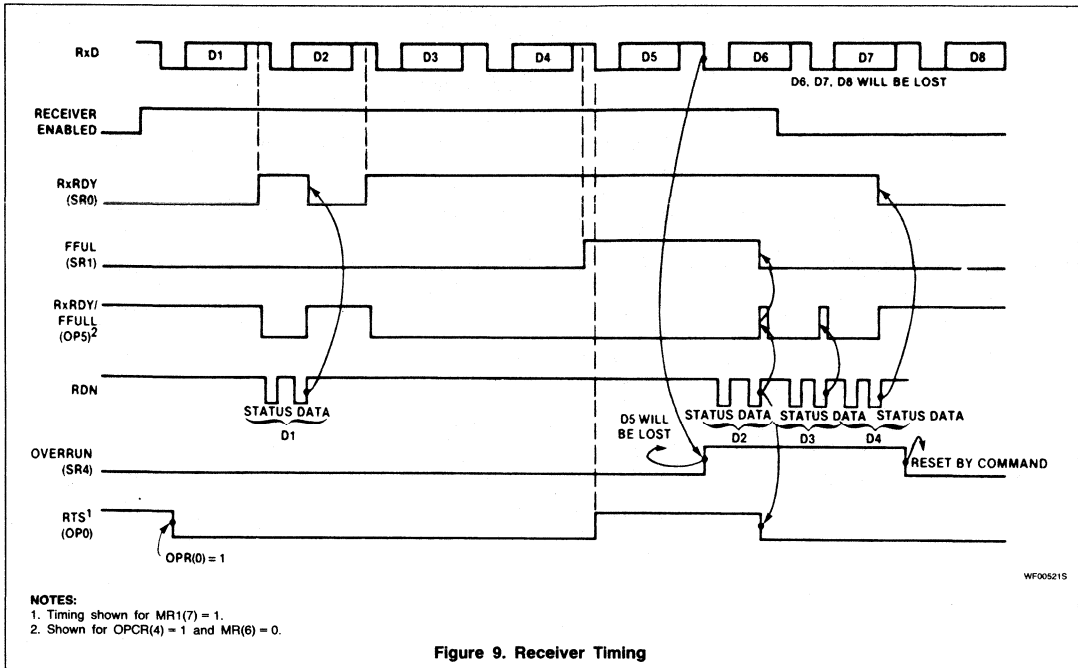

# SCC2698

## Octal Universal Asynchronous Receiver/Transmitter (Octal-UART)

### Microprocessor Products

Preliminary Specification

### DESCRIPTION

The Signetics SCC2698 Octal Universal Asynchronous Receiver/Transmitter (Octal-UART) is a single-chip MOS-LSI communications device that provides an eight-channel full-duplex asynchronous receiver/transmitter in a single package. It is fabricated with Signetics' CMOS technology, which combines the benefits of high density and low power consumption.

The operating speed of each receiver and transmitter can be selected independently as one of eighteen fixed baud rates, a  $16\times$  clock derived from a programmable counter/timer, or an external  $1\times$  or  $16\times$  clock. The baud rate generator and counter/timer can operate directly from a crystal or from external clock inputs. The ability to independently program the operating speed of the receiver and transmitter make the Octal-UART particularly functional for dual-speed channel applications such as clustered terminal systems.

The receiver is quadruply buffered to minimize the potential of receiver overrun, or to reduce interrupt overhead in interrupt driven systems. In addition, a handshaking capability is provided to disable a remote UART transmitter when the receiver buffer is full.

The Octal-UART provides a power-down mode in which the oscillator is frozen but the register contents are stored. This results in reduced power consumption on the order of several magnitudes. The Octal-UART is fully TTL compatible and operates from a single +5V power supply.

### FEATURES

- Eight full-duplex asynchronous receiver/transmitters
- Quadruple buffered receiver data register
- Programmable data format:
  - 5 to 8 data bits plus parity
  - Odd, even, no parity or force parity
  - 1, 1.5 or 2 stop bits programmable in  $1/16$ -bit increments
- Baud rate for the receiver and transmitter selectable from:
  - 18 fixed rates: 50 to 38.4k baud
  - Four user-defined rates derived from the programmable counter/timer associated with each of the four blocks
  - External  $1\times$  or  $16\times$  clock
- Parity, framing, and overrun error detection
- False start bit detection
- Line break detection and generation
- Programmable channel mode
  - Normal (full-duplex), automatic echo, local loopback, remote loopback
- Four multi-function programmable 16-bit counter/timers
- Four interrupt outputs with eight maskable interrupting conditions for each output
- On-chip crystal oscillator
- TTL compatible
- Single +5V power supply with low power mode

### PIN CONFIGURATIONS

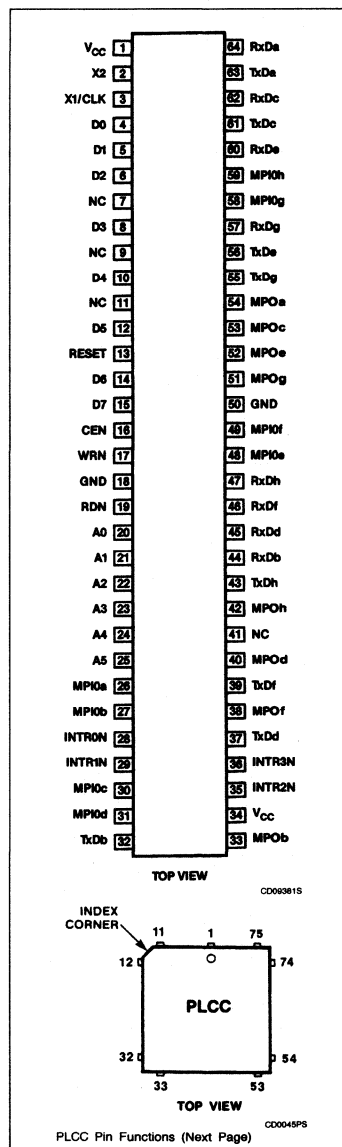

# Octal Universal Asynchronous Receiver/Transmitter (Octal-UART)

## SCC2698

### ORDERING INFORMATION

PACKAGES	$V_{CC} = +5V \pm 5\%$ , $T_A = 0$ to $+70^\circ C$
Plastic DIP	SCC2698AC1N64
Plastic LCC	SCC2698AC1A84

### PIN CONFIGURATIONS (Continued)

Pin	Function	PLCC	Pin	Function
1	TxDa	43	MPOb	
2	MPI13g	44	MPI2d	
3	RxDa	45	V <sub>CC</sub>	
4	MPI13h	46	INTR2N	
5	V <sub>CC</sub>	47	INTR3N	
6	X2	48	MPI3c	
7	X1/CLK	49	TxDd	
8	D0	50	MPI3d	
9	D1	51	MPOd	
10	D2	52	TxDf	
11	D3	53	MPOf	
12	D4	54	MPOh	
13	D5	55	TxDh	
14	MPI1a	56	RxDb	
15	RESET	57	RxDd	
16	D6	58	RxDf	
17	D7	59	RxDh	
18	CEN	60	MPI1e	
19	WRN	61	MPI0e	
20	GND	62	MPI1f	
21	MPI1b	63	MPI0f	
22	RDN	64	MPI2e	
23	A0	65	GND	
24	MPI2a	66	MPI2f	
25	A1	67	MPOg	
26	MPI2b	68	MPI3e	
27	A2	69	MPOe	
28	MPI3a	70	MPI3f	
29	A3	71	MPOc	
30	MPI3b	72	MPOa	
31	A4	73	TxDg	
32	A5	74	TxDe	
33	MPI0a	75	RxDg	
34	MPI0b	76	MPI0g	
35	INTRON	77	MPI0h	
36	INTR1N	78	MPI1g	
37	MPI0c	79	RxDc	
38	MPI1c	80	MPI1h	
39	MPI0d	81	TxDc	
40	MPI1d	82	MPI2g	
41	TxDb	83	RxDc	
42	MPI2c	84	MPI2h	

### BLOCK DIAGRAM

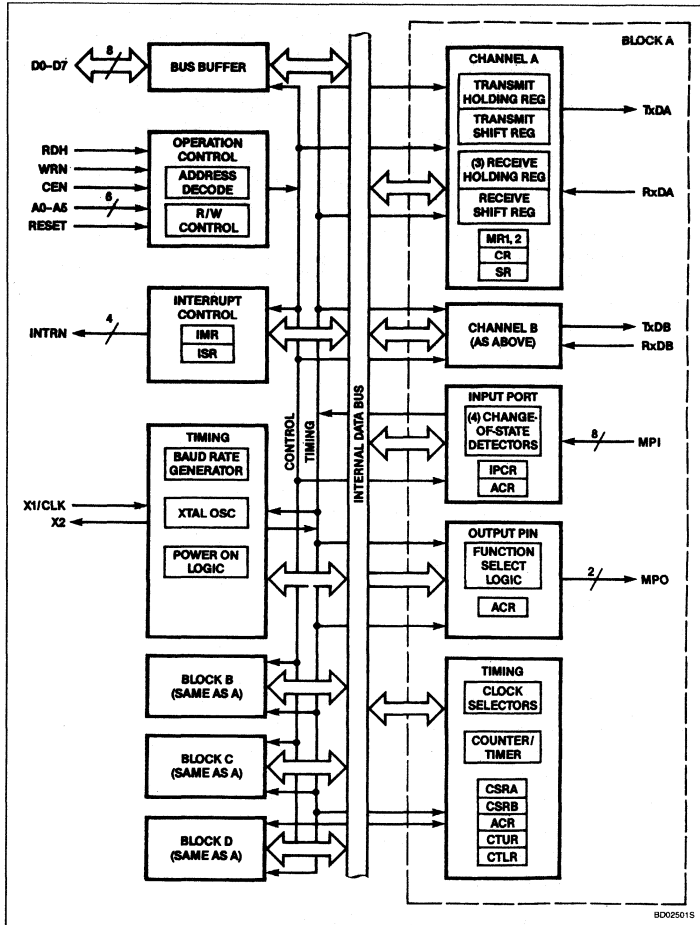

# Octal Universal Asynchronous Receiver/Transmitter (Octal-UART)

## SCC2698

### PIN DESCRIPTION

MNEMONIC	PIN NO.		TYPE	NAME AND FUNCTION
	DIP	PLCC		
D0 – D7	4 – 6, 8, 10, 12, 14, 15	8 – 13, 16, 17	I/O	<b>Data Bus:</b> Active high 8-bit bidirectional 3-State data bus. Bit 0 is the LSB and bit 7 is the MSB. All data, command, and status transfers between the CPU and the Octal-UART take place over this bus. The direction of the transfer is controlled by the WRN and RDN inputs when the CEN input is low. When the CEN input is high, the data bus is in the 3-State condition.
CEN	16	18	I	<b>Chip Enable:</b> Active low input. When low, data transfers between the CPU and the Octal-UART are enabled on D0 – D7 as controlled by the WRN, RDN, and A0 – A5 inputs. When CEN is high, the Octal-UART is effectively isolated from the data bus and D0 – D7 are placed in the 3-State condition.
WRN	17	19	I	<b>Write Strobe:</b> Active low input. A low on this pin while CEN is low causes the contents of the data bus to be transferred to the register selected by A0 – A5. The transfer occurs on the trailing (rising) edge of the signal.
RDN	19	22	I	<b>Read Strobe:</b> Active low input. A low on this pin while CEN is low causes the contents of the register selected by A0 – A5 to be placed on the data bus. The read cycle begins on the leading (falling) edge of RDN.
A0 – A5	20 – 25	23, 25, 27, 29, 31, 32	I	<b>Address Inputs:</b> Active high address inputs to select the Octal-UART registers for read/write operations.
RESET	13	15	I	<b>Reset:</b> Master reset. A high on this pin clears the status register (SR), clears the interrupt mask register (IMR), clears the interrupt status register (ISR), clears the output port configuration register (OPCR), places the receiver and transmitter in the inactive state causing the TxD output to go to the marking (high) state, and stops the counter/timer.
INTR0N – INTR3N	28, 29, 35, 36	35, 36, 46, 47	O	<b>Interrupt Request:</b> This active low open drain output is asserted on occurrence of one or more of eight maskable interrupting conditions. The CPU can read the interrupt status register to determine the interrupting condition(s).
X1/CLK	3	7	I	<b>Crystal 1:</b> Crystal or external clock input. When using the crystal oscillator, this pin serves as the connection for one side of the crystal. If a crystal is not used, an external clock is supplied at this input. An external clock (or crystal) is required even if the internal baud rate generator is not utilized. This clock is used to drive the internal baud rate generator, as an optional input to the timer/counter, and to provide other clocking signals required by the chip.
X2	2	6	I	<b>Crystal 2:</b> Connection for other side of crystal. If an external source is used instead of a crystal, this should be open or connected as shown in Figure 6.
RxDa – RxDh	64, 44, 62, 45, 60, 46, 57, 47	3, 56, 83, 57, 79, 58, 75, 59		<b>Receiver Serial Data Input:</b> The least significant bit is received first. If external receiver clock is specified, this input is sampled on the rising edge of the clock.



# Octal Universal Asynchronous Receiver/Transmitter (Octal-UART)

SCC2698

## PIN DESCRIPTION (Continued)

MNEMONIC	PIN NO.		TYPE	NAME AND FUNCTION
	DIP	PLCC		
TxDa – TxDh	63, 32, 61, 37, 56, 39, 55, 43	1, 41, 81, 49, 74, 52, 73, 55	O	<b>Transmitter Serial Data Output:</b> Transmitter serial data output. The least significant bit is transmitted first. This output is held in the marking (high) condition when the transmitter is idle or disabled and when the Octal-UART is operating in local loopback mode. If external transmitter clock is specified, the data is shifted on the falling edge of the transmitter clock.
MPOa – MPOh	54, 33, 53, 38, 52, 40, 51, 42	72, 43, 71, 51, 69, 53, 67, 54	O	<b>Multi-Purpose Output:</b> One of the following functions can be selected for this output pin by programming the output port configuration register: <b>RTSN</b> — Request to send active low output. This output is asserted and negated via the command register. By appropriate programming of the mode registers, RTSN can be programmed to be automatically reset after the character in the transmitter is completely shifted or when the receiver FIFO and shift register are full. <b>C/TO</b> — Counter/timer output <b>TxC1 ×</b> — 1× clock for the transmitter <b>TxC16 ×</b> — 16× clock for the transmitter <b>RxC1 ×</b> — 1× clock for the receiver <b>RxC16 ×</b> — 16× clock for the receiver <b>TxRDY</b> — Transmitter holding register empty signal <b>RxRDY/FFULL</b> — Receiver FIFO not empty/full signal
MPIOa – MPIOh	26, 27, 30, 31, 48, 49, 58, 59	33, 34, 37, 39, 61, 63, 76, 77	I	<b>Multi-Purpose Input 0:</b> This pin can be programmed to serve as an input for one of the following functions: <b>GPI</b> — General purpose input. The current state of the pin can be determined by reading the IPCR or input port register. <b>CTSN</b> — Clear-to-Send active low input.
MPI1a – MPI1h	NC	14, 21, 38, 40, 60, 62, 78, 80	I	<b>Multi-Purpose Input 1:</b> This pin can be programmed to serve as an input for one of the following functions: <b>GPI</b> — General purpose input. The current state of the pin can be determined by reading the IPCR or input port register. <b>CTCLK</b> — Counter/timer external clock input. Only channels a, c, e, and g change to C/T inputs; channels b, d, f and h stays GPI.
MPI2a – MPI2h	NC	24, 26, 42, 44, 64, 66, 82, 84	I	<b>Multi-Purpose Input 2:</b> This pin can be programmed to serve as an input for one of the following functions: <b>GPI</b> — General purpose input. The current state of the pin can be determined by reading the input port register. <b>TCLK</b> — Transmitter external clock input. This may be a 1× or 16× clock as programmed by CSR[3:0].
MPI3a – MPI3h	NC	28, 30, 48, 50, 68, 70, 2, 4	I	<b>Multi-Purpose Input 3:</b> This pin can be programmed to serve as an input for one of the following functions: <b>GPI</b> — General purpose input. The current state of the pin can be determined by reading the input port register. <b>RCLK</b> — Receiver external clock input. This may be a 1× or 16× clock as programmed by CSR[7:4].
V <sub>CC</sub>	1, 34	5, 45	I	<b>Power Supply:</b> +5V supply input
GND	18, 50	20, 65	I	<b>Ground</b>

# Octal Universal Asynchronous Receiver/Transmitter (Octal-UART)

## SCC2698

### BLOCK DIAGRAM

As shown on the block diagram, the Octal-UART consists of: data bus buffer, interrupt control, operation control, timing, and eight receiver and transmitter channels. The eight channels are divided into four different blocks each block independent of each other (see Figure 1).

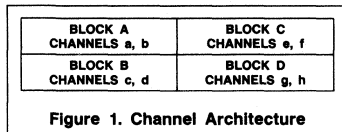

### Channel Blocks

There are four blocks (Figure 1), each containing two sets of receiver/transmitters. In the following discussion, the description applies to block A which contains channels a and b. However, the same information applies to all channel blocks.

### Data Bus Buffer

The data bus buffer provides the interface between the external and internal data buses. It is controlled by the operation control block to allow read and write operations to take place between the controlling CPU and the Octal-UART.

### Interrupt Control

A single interrupt output (INTRN) is provided which is asserted on the occurrence of any of the following internal events:

- Transmit holding register ready for each channel
- Receive holding register ready or FIFO full for each channel
- Change in break received status for each channel
- Counter reached terminal count
- Change in MPI input

Associated with the interrupt system are the interrupt mask register (IMR) and the interrupt status register (ISR). The IMR can be programmed to select only certain conditions, of the above, to cause INTRN to be asserted. The ISR can be read by the CPU to determine all currently active interrupting conditions. However, the bits of the ISR are not masked by the IMR.

### Operation Control

The operation control logic receives operation commands from the CPU and generates appropriate signals to internal sections to control device operation. It contains address decoding and read and write circuits to permit communications with the microprocessor via the data bus buffer. The functions performed by the CPU read and write operations are shown in Table 1.

Mode registers 1 and 2 are accessed via an auxiliary pointer. The pointer is set to MR1 by RESET or by issuing a reset pointer command via the command register. Any read or write of the mode register while the pointer is at MR1 switches the pointer to MR2. The pointer then remains at MR2 so that subsequent accesses are to MR2, unless the pointer is reset to MR1 as described above.

### Timing Circuits

The timing block consists of a crystal oscillator, a baud rate generator, a programmable 16-bit counter/timer for each block, and two clock selectors.

The crystal oscillator operates directly from a 3.6864MHz crystal connected across the X1/CLK and X2 inputs with a minimum of external components. If an external clock of the appropriate frequency is available, it may be connected to X1/CLK. If an external clock is used instead of a crystal, both X1 and X2 are driven using a configuration similar to the one in Figure 6. Also, an arrangement where X2 is floating can be used, however, the input high voltage must be capable of attaining 4.4V. The clock serves as the basic timing reference for the baud rate generator (BRG), the counter/timer, and other internal circuits. A clock frequency, within the limits specified in the electrical specifications, must be supplied even if the internal BRG is not used.

The baud rate generator operates from the oscillator or external clock input and is capable of generating 18 commonly used data communications baud rates ranging from 50 to 38.4k baud. Thirteen of these are available simultaneously for use by the receiver and transmitter. Eight are fixed, and one of two sets of five can be selected by programming ACR[7]. The clock outputs from the BRG are at  $16\times$  the actual baud rate. The counter/timer can be used as a timer to produce a  $16\times$  clock for any other baud rate by counting down the crystal clock or an external clock. The clock selectors allow the independent selection, by the receiver and transmitter, of any of these baud rates or an external timing signal.

There are four C/Ts in the Octal-UART, one for each block. The C/T operation is programmed by ACR[6:4]. One of eight timing sources can be used as the input to the C/T. The output of the C/T is available to the clock selectors and can also be programmed by OPCR[2:0] for channel a and OPCR[6:4] for channel b, to be output on the MPOa or MPOb pin, respectively.

In the timer mode, the C/T generates a square wave whose period is twice the number of clock periods loaded into the C/T upper and lower registers. The counter ready bit in the ISR is set once each cycle of the square wave. If the value in CTUR or CTRL is

changed, the current half-period will not be affected, but subsequent half periods will be affected. In this mode, the C/T runs continuously and does not recognize the stop C/T command (the command only resets the counter ready bit in the ISR). Receipt of a start C/T command causes the C/T to terminate the current timing cycle and to begin a new cycle using the values in CTUR and CTRL.

In the counter mode, the C/T counts down the number of pulses loaded into CTUR and CTRL. Counting begins upon receipt of a start counter command. Upon reaching terminal count, the counter ready bit in the ISR is set. The counter continues counting past the terminal count until stopped by the CPU. If MPO is programmed to be the output of the C/T, the output remains high until terminal count is reached, at which time it goes low. The output returns to the high state and the counter ready bit is cleared when the counter is stopped by a stop counter command. The CPU may change the values of CTUR and CTRL at any time, but the new count becomes effective only on the next start counter command following a stop counter command. If new values have not been loaded, the previous count values are preserved and used for the next count cycle.

In the counter mode, the current value of the upper and lower eight bits of the counter may be read by the CPU. It is recommended that the counter be stopped when reading to prevent potential problems, which may occur, if a carry from the lower eight bits to the upper eight bits occurs between the times both halves of the counter are read. However, a subsequent start counter command causes the counter to begin a new count cycle using the values in CTUR and CTRL.

### Receiver and Transmitter

The Octal-UART has eight full-duplex asynchronous receiver/transmitters. The operating frequency for the receiver and transmitter can be selected independently from the baud rate generator, the counter timer, or from an external input.

Registers associated with the communications channel are the mode registers (MR1 and MR2), the clock select register (CSR), the command register (CR), the status register (SR), the transmit holding register (THR), and the receive holding register (RHR).

### Transmitter

The transmitter accepts parallel data from the CPU and converts it to a serial bit stream on the TxD output pin. It automatically sends a start bit followed by the programmed number of data bits, an optional parity bit, and the programmed number of stop bits. The least significant bit is sent first. Following the transmission of the stop bits, if a new character is

# Octal Universal Asynchronous Receiver/Transmitter (Octal-UART)

SCC2698

Table 1. Register Addressing

A5	A4	A3	A2	A1	A0	READ (RDN = 0)	WRITE (WRN = 0)	A5	A4	A3	A2	A1	A0	READ (RDN = 0)	WRITE (WRN = 0)
0	0	0	0	0	0	MR1a, MR2a	MR1a, MR2a	1	0	0	0	0	0	MR1e, MR2e	MR1e, MR2e
0	0	0	0	0	1	SRa	CSRa	1	0	0	0	0	1	SRe	CSRe
0	0	0	0	1	0	Reserved*	CRa	1	0	0	0	1	0	Reserved*	CRe
0	0	0	0	1	1	RHRa	THRa	1	0	0	0	1	1	RHRe	THRe
0	0	0	1	0	0	IPCRA	ACRA	1	0	0	1	0	0	IPCRC	ACRC
0	0	0	1	0	1	ISRA	IMRA	1	0	0	1	0	1	ISRC	IMRC
0	0	0	1	1	0	CTUA	CTURA	1	0	0	1	1	0	CTUC	CTURC
0	0	0	1	1	1	CTLA	CTLRA	1	0	0	1	1	1	CTLC	CTLRC
0	0	1	0	0	0	MR1b, MR2b	MR1b, MR2b	1	0	1	0	0	0	MR1f, MR2f	MR1f, MR2f
0	0	1	0	0	1	SRb	CSRb	1	0	1	0	0	1	SRf	CSRf
0	0	1	0	1	0	Reserved*	CRb	1	0	1	0	1	0	Reserved*	CRf
0	0	1	0	1	1	RHRb	THRb	1	0	1	0	1	1	RHRf	THRf
0	0	1	1	0	0	Reserved*	Reserved*	1	0	1	1	0	0	Reserved*	Reserved*
0	0	1	1	0	1	Input port A	OPCRA	1	0	1	1	0	1	Input port C	OPCRC
0	0	1	1	1	0	Start C/T A	Reserved*	1	0	1	1	1	0	Start C/T C	Reserved*
0	0	1	1	1	1	Stop C/T A	Reserved*	1	0	1	1	1	1	Stop C/T C	Reserved*
0	1	0	0	0	0	MR1c, MR2c	MR1c, MR2c	1	1	0	0	0	0	MR1g, MR2g	MR1g, MR2g
0	1	0	0	0	1	SRc	CSRc	1	1	0	0	0	1	SRg	CSRg
0	1	0	0	1	0	Reserved*	CRc	1	1	0	0	1	0	Reserved*	CRg
0	1	0	0	1	1	RHRc	THRc	1	1	0	0	1	1	RHRg	THRg
0	1	0	1	0	0	IPCRB	ACRB	1	1	0	1	0	0	IPCRD	ACRD
0	1	0	1	0	1	ISRB	IMRB	1	1	0	1	0	1	ISRd	IMRD
0	1	0	1	1	0	CTUB	CTURB	1	1	0	1	1	0	CTUD	CTURD
0	1	0	1	1	1	CTLB	CTLRB	1	1	0	1	1	1	CTLD	CTLRD
0	1	1	0	0	0	MR1d, MR2d	MR1d, MR2d	1	1	1	0	0	0	MR1h, MR2h	MR1h, MR2h
0	1	1	0	0	1	SRd	CSRd	1	1	1	0	0	1	SRh	CSRh
0	1	1	0	1	0	Reserved*	CRd	1	1	1	0	1	0	Reserved*	CRh
0	1	1	0	1	1	RHRd	THRd	1	1	1	0	1	1	RHRh	THRh
0	1	1	1	0	0	Reserved*	Reserved*	1	1	1	1	0	0	Reserved*	Reserved*
0	1	1	1	0	1	Input port B	OPCRB	1	1	1	1	0	1	Input port D	OPCRD
0	1	1	1	1	0	Start C/T B	Reserved*	1	1	1	1	1	0	Start C/T D	Reserved*
0	1	1	1	1	1	Stop C/T B	Reserved*	1	1	1	1	1	1	Stop C/T D	Reserved*

**NOTES:**

\*Reserved registers should never be read during normal operation since they are reserved for internal diagnostics.

- ACR = Auxiliary control register
- CR = Command register
- CSR = Clock select register
- CTL = Counter/timer lower
- CTLR = Counter/timer lower register
- CTU = Counter/timer upper
- CTUR = Counter/timer upper register
- MR = Mode register
- SR = Status register
- THR = Tx holding register
- RHR = Rx holding register
- IPCR = Input port change register
- ISR = Interrupt status register
- IMR = Interrupt mask register
- OPCR = Output port configuration register

# Octal Universal Asynchronous Receiver/Transmitter (Octal-UART)

SCC2698

not available in the THR, the TxD output remains high and the TxEMT bit in the SR will be set to 1. Transmission resumes and the TxEMT bit is cleared when the CPU loads a new character into the THR. In the  $16\times$  clock mode, this also resynchronizes the internal  $1\times$  transmitter clock so that transmission of the new character begins with minimum delay.

The transmitter can be forced to send a break (continuous low condition) by issuing a start break command via the CR. The break is terminated by a stop break command. If the transmitter is disabled, it continues operating until the character currently being transmitted and the character in the THR, if any, are completely sent out. Characters cannot be loaded into the THR while the transmitter is disabled.

## Receiver

The receiver accepts serial data on the RxD pin, converts the serial input to parallel format, checks for start bit, stop bit, parity bit (if any), or break condition, and presents the assembled character to the CPU. The receiver looks for a high-to-low (mark-to-space) transition of the start bit on the RxD input pin. If a transition is detected, the state of the RxD pin is sampled again each  $16\times$  clock for  $7\frac{1}{2}$  clocks ( $16\times$  clock mode) or at the next rising edge of the bit time clock ( $1\times$  clock mode).

If RxD is sampled high, the start bit is invalid and the search for a valid start bit begins again. If RxD is still low, a valid start bit is assumed and the receiver samples the input. This continues at one-bit time intervals, at the theoretical center of the bit, until the proper number of data bits and the parity bit (if any) have been assembled, and one stop bit has been detected. The least significant bit is received first. The data is then transferred to the RHR and the RxRDY bit in the SR is set to a one. If the character length is less than eight bits, the most significant unused bits in the RHR are set to zero.

After the stop bit is detected, the receiver will immediately look for the next start bit. However, if a non-zero character was received without a stop bit (i.e. framing error) and RxD remains low for one-half of the bit period after the stop bit was sampled, then the receiver operates as if a new start bit transition had been detected at that point (one-half bit time after the stop bit was sampled). The parity error, framing error and overrun error (if any) are strobed into the SR at the received character boundary, before the RxRDY status bit is set.

If a break condition is detected (RxD is low for the entire character including the stop bit), only one character consisting of all zeros will be loaded into the FIFO and the received break bit in the SR is set to 1. The RxD input

must return to a high condition for two successive clock edges of the  $1\times$  clock (internal or external) before a search for the next start bit begins.

## TIME OUT MODE

Under certain conditions the user may want to set the receiver to interrupt the CPU when the receiver FIFO becomes full. This can be accomplished by programming MR1[6] = 1. If a message that is only one or two characters long is received, the FIFO is not full so that ISR[1] does not set and the CPU is not interrupted. The CPU will not know that there is data in the receive FIFO. The time-out mode provides the user with a time-out interrupt via the C/T. If a character is received and the FIFO does not become full, a pre-selected period of delay can be timed out by the C/T and the CPU interrupted.

This mode is enabled by writing the appropriate command to the command register. Writing an "AX" to CRA or CRB will invoke the time-out mode for that channel. Writing a "CX" to CRA or CRB will reset the time-out mode. CTU and CTL must be loaded with a value greater than the normal receive character period. Each time a received character is transferred from the shift register to the RHR, the C/T is reloaded with the value in CTU and CTL and then restarted. If the C/T is allowed to end the count, the counter ready bit (ISR[3]) will be set. If IMR[3] is set, an interrupt will occur.

## RECEIVER FIFO

The RHR consists of a first-in-first-out (FIFO) with a capacity of three characters. Data is loaded from the receive shift register into the top-most empty position of the FIFO. The RxRDY bit, in the status register (SR), is set whenever one or more characters are available to be read, and a FFULL status bit is set if all three positions are filled with data. Either of these bits can be selected to cause an interrupt. A read of the RHR, outputs the data at the top of the FIFO. After the read cycle, the data FIFO and its associated status bits are 'popped', thus emptying a FIFO position for new data.

In addition to the data word, three status bits (parity error, framing error, and received break) are appended to each data character in the FIFO. Status can be provided in two ways, as programmed by the error mode control bit in the mode register. In the 'character' mode, status is provided on a character-by-character basis; the status applies only to the character at the top of the FIFO. In the 'block' mode, the status provided in the SR for these three bits is the logical-OR of the status for all characters coming to the top of

the FIFO, since the last reset error command was issued. In either mode, reading the SR does not affect the FIFO. The FIFO is 'popped' only when the RHR is read. Therefore, the SR should be read prior to reading the corresponding data character.

If the FIFO is full when a new character is received, that character is held in the receive shift register until a FIFO position is available. If an additional character is received while this state exists, the contents of the FIFO are not affected: the character previously in the shift register is lost and the overrun error status bit, SR[4], will be set on receipt of the start bit of the new (overrunning) character.

## WAKE-UP MODE

In addition to the normal transmitter and receiver operation described above, the Octal-UART incorporates a special mode which provides automatic wake-up of the receiver through address frame recognition for multiprocessor communications. This mode is selected by programming bits MR1[4:3] to '11'.

In this mode of operation, a 'master' station transmits an address character followed by data characters for the addressed 'slave' station. The slave stations, whose receivers are normally disabled, examine the received data stream and 'wake up' the CPU (by setting RxRDY) only upon receipt of an address character. The CPU compares the received address to its station address and enables the receiver if it wishes to receive the subsequent data characters. Upon receipt of another address character, the CPU may disable the receiver to initiate the process again.

A transmitted character consists of a start bit, the programmed number of data bits, an address/data (A/D) bit, and the programmed number of stop bits. The polarity of the transmitted A/D bit is selected by the CPU by programming bit MR1[2]; MR1[2] = 0 transmits a zero in the A/D bit position which identifies the corresponding data bits as data, MR1[2] = 1 transmits a one in the A/D bit position which identifies the corresponding data bits as an address. The CPU should program the mode register prior to loading the corresponding data bits into the THR.

While in this mode, the receiver continuously looks at the received data stream, whether it is enabled or disabled. If disabled, it sets the RxRDY status bit and loads the character into the RHR FIFO if the received A/D bit is a one, but discards the received character if the received A/D bit is a zero. If enabled, all received characters are transferred to the CPU via the RHR. In either case, the data bits are loaded into the data FIFO while the A/D bit is loaded into the status FIFO position

# Octal Universal Asynchronous Receiver/Transmitter (Octal-UART)

## SCC2698

normally used for parity error (SR[5]). Framing error, overrun error, and break detect operate normally whether or not the receiver is enabled.

### MULTI-PURPOSE INPUT PIN

The inputs to this unlatched 8-bit port for each block can be read by the CPU, by performing a read operation as shown in Table 1. A high input results in a logic one while a low input results in a logic zero. When the input port pins are read on the 84-pin PLCC, they will appear on the data bus in alternating pairs. (i.e., DB0 = MPI0a, DB1 = MPI1a, DB2 = MPI0b, DB3 = MPI1b, DB4 = MPI2a, DB5 = MPI3a, DB6 = MPI2b, DB7 = MPI3b. Although this example is shown for input port 'A', all input ports will have a similar order).

The MPI pins can be programmed as an input to one of several Octal-UART circuits. The function of the pin is selected by programming the appropriate control register. Change-of-state detectors are provided for MPI0 and MPI1 for each channel in each block. A high-to-low or low-to-high transition of the inputs lasting longer than 25 to 50 $\mu$ s sets the MPI change-of-state bit in the interrupt status register. The bit is cleared via a command. The change-of-state can be programmed to generate an interrupt to the CPU, by setting the corresponding bit in the interrupt mask register.

The input port pulse detection circuitry uses a 38.4kHz sampling clock, derived from one of the baud rate generator taps. This produces a sampling period of slightly more than 25 $\mu$ s (assuming a 3.6864MHz oscillator input). The detection circuitry, in order to guarantee that a true change in level has occurred, requires two successive samples be observed at the new logic level. As a consequence, the minimum duration of the signal change is 25 $\mu$ s if the transition occurs coincident with the first sample pulse. (The 50 $\mu$ s time refers to the condition where the change-of-state is just missed and the first change-of-state is not detected until after an additional 25 $\mu$ s.)

### MULTI-PURPOSE OUTPUT PIN

This pin can be programmed to serve as a request-to-send output, the counter/timer output, the output for the 1 $\times$  or 16 $\times$  transmitter or receiver clocks, the TxRDY output or the RxRDY/FFULL output (see OPCR [2:0] and OPCR [6:4] — MPO Output Select).

### REGISTERS

The operation of the Octal-UART is programmed by writing control words into the appropriate registers. Operational feedback is

provided via registers which can be read by the CPU. Addressing the registers is described in Table 1.

If the contents of the MR, the CSR, the OPCR and ACR are changed while the receiver(s) and transmitter(s) are enabled, the registers will not be updated until both the transmitter(s) are empty and the receiver(s) disabled. The receiver(s) will be disabled, at the completion of the character being received, at the time of the register change. Normally these registers should not be updated without first making sure that the receiver(s) and transmitter(s) are disabled, and the C/T is stopped.

The bit formats of the Octal-UART registers are depicted in Table 2. These are shown for block A. The bit format for the other blocks is the same.

#### MR1 — Mode Register 1

MR1 is accessed when the MR pointer points to MR1. The pointer is set to MR1 by RESET or by a set pointer command applied via CR. After reading or writing MR1, the pointers are set at MR2.

#### MR1[7] — Receiver Request-to-Send Control

This bit controls the deactivation of the RTSN output (MPO) by the receiver. This output is manually asserted and negated by commands applied via the command register. MR1[7] = 1 causes RTSN to be automatically negated upon receipt of a valid start bit if the receiver FIFO is full. RTSN is reasserted when an empty FIFO position is available. This feature can be used to prevent overrun in the receiver, by using the RTSN output signal, to control the CTS input of the transmitting device.

#### MR1[6] — Receiver Interrupt Select

This bit selects either the receiver ready status (RxRDY) or the FIFO full status (FFULL) to be used for CPU interrupts.

#### MR1[5] — Error Mode Select

This bit selects the operating mode of the three FIFOed status bits (FE, PE, received break). In the character mode, status is provided on a character-by-character basis; the status applies only to the character at the top of the FIFO. In the block mode, the status provided in the SR for these bits is the accumulation (logical-OR) of the status for all characters coming to the top of the FIFO, since the last reset error command was issued.

#### MR1[4:3] — Parity Mode Select

If 'with parity' or 'force parity' is selected, a parity bit is added to the transmitted character and the receiver performs a parity check on incoming data. MR1[4:3] = 11 selects the channel to operate in the special wake-up mode.

#### MR2[1] — Parity Type Select

This bit selects the parity type (odd or even) if the 'with parity' mode is programmed by MR1[4:3], and the polarity of the forced parity bit if the 'force parity' mode is programmed. It has no effect if the 'no parity' mode is programmed. In the special 'wake-up' mode, it selects the polarity of the A/D bit.

#### MR2[1:0] — Bits per Character Select

This field selects the number of data bits per character to be transmitted and received. The character length does not include the start, parity, and stop bits.

#### MR2 — Mode Register 2

MR2 is accessed when the channel A MR pointer points to MR2, which occurs after any access to MR1. Accesses to MR2 do not change the pointer.

#### MR2[7:6] — Mode Select

The Octal-UART can operate in one of four modes: MR2[7:6] = 00 is the normal mode, with the transmitter and receiver operating independently. MR2[7:6] = 01 places the channel in the automatic echo mode, which automatically retransmits the received data. The following conditions are true while in automatic echo mode:

1. Received data is reclocked and retransmitted on the TxD output.
2. The receive clock is used for the transmitter.
3. The receiver must be enabled, but the transmitter need not be enabled.
4. The TxRDY and TxEMT status bits are inactive.
5. The received parity is checked, but is not regenerated for transmission, i.e., transmitted parity bit is as received.
6. Character framing is checked, but the stop bits are retransmitted as received.
7. A received break is echoed as received until the next valid start bit is detected.
8. CPU-to-receiver communications continue normally, but the CPU-to-transmitter link is disabled.

Two diagnostic modes can also be selected. MR2[7:6] = 10 selects local loopback mode. In this mode:

1. The transmitter output is internally connected to the receiver input.
2. The transmit clock is used for the receiver.
3. The TxD output is held high.
4. The RxD input is ignored.
5. The transmitter must be enabled, but the receiver need not be enabled.
6. CPU-to-transmitter and receiver communications continue normally.

# Octal Universal Asynchronous Receiver/Transmitter (Octal-UART)

SCC2698

The second diagnostic mode is the remote loopback mode, selected by MR2[7:6] = 11. In this mode:

1. Received data is reclocked and retransmitted on the TxD output.
2. The receive clock is used for the transmitter.
3. Received data is not sent to the local CPU, and the error status conditions are inactive.
4. The received parity is not checked and is not regenerated for transmission, i.e., the transmitted parity bit is as received.
5. The receiver must be enabled, but the transmitter need not be enabled.
6. Character framing is not checked, and the stop bits are retransmitted as received.
7. A received break is echoed as received until the next valid start bit is detected.

When switching in and out of the various modes, the selected mode is activated at the completion of all transmitted and received characters. Likewise, if a mode is deselected, the device will switch out of the mode at the completion of the current transmit and/or receive characters.

### MR2[5] — Transmitter Request-to-Send Control

This bit controls the deactivation of the RTSN output (MPO) by the transmitter. This output is manually asserted and negated by appropriate commands issued via the command register. MR2[5] = 1 causes RTSN to be reset automatically one bit time after the characters in the transmit shift register and in the THR (if any) are completely transmitted (includes the programmed number of stop bits if the transmitter is not enabled). This feature can be used to automatically terminate the transmission of a message as follows:

1. Program auto-reset mode: MR2[5] = 1.
2. Enable transmitter.
3. Assert RTSN via command.
4. Send message.
5. Verify the next to last character of the message is being sent by waiting until transmitter ready is asserted. Disable transmitter after the last character is loaded into the THR.
6. The last character will be transmitted and RTSN will be reset one bit time after the last stop bit.

### MR2[4] — Clear-to-Send Control

The state of this bit determines if the CTSN input (MPI) controls the operation of the transmitter. If this bit is 0, CTSN has no effect on the transmitter. If this bit is a 1, the transmitter checks the state of CTSN each time it is ready to send a character. If it is asserted (low), the character is transmitted. If it is negated (high), the TxD output remains in the marking state and the transmission is delayed until CTSN goes low. Changes in CTSN, while a character is being transmitted, do not affect the transmission of that character. This feature can be used to prevent overrun of a remote receiver.

### MR2[3:0] — Stop Bit Length Select

This field programs the length of the stop bit appended to the transmitted character. Stop bit lengths of  $\frac{9}{16}$  to 1 and  $\frac{19}{16}$  to 2 bits, in increments of  $\frac{1}{16}$  bit, can be programmed for character lengths of 6, 7, and 8 bits. For a character length of 5 bits,  $\frac{17}{16}$  to 2 stop bits can be programmed in increments of  $\frac{1}{16}$  bit. In all cases, the receiver only checks for a mark condition at the center of the first stop bit position (one bit time after the last data bit, or after the parity bit if parity is enabled). If an external  $1 \times$  clock is used for the transmitter, MR2[3] = 0 selects one stop bit and MR2[3] = 1 selects two stop bits to be transmitted.

Table 2. Register Bit Formats

	BIT 7	BIT 6	BIT 5	BIT 4	BIT 3	BIT 2	BIT 1	BIT 0
	<b>RxRTS CONTROL</b>	<b>RxINT SELECT</b>	<b>ERROR MODE</b>	<b>PARITY MODE</b>	<b>PARITY TYPE</b>	<b>BITS PER CHARACTER</b>		
MR1	0 = no 1 = yes	0 = RxRDY 1 = FFULL	0 = char 1 = block	00 = with parity 01 = force parity 10 = no parity 11 = special mode	0 = even 1 = odd	00 = 5 01 = 6 10 = 7 11 = 8		

	BIT 7	BIT 6	BIT 5	BIT 4	BIT 3	BIT 2	BIT 1	BIT 0
	<b>CHANNEL MODE</b>		<b>TxRTS CONTROL</b>	<b>CTS ENABLE Tx</b>	<b>STOP BIT LENGTH*</b>			
MR2	00 = Normal 01 = Auto-echo 10 = Local loop 11 = Remote loop		0 = no 1 = yes	0 = no 1 = yes	0 = 0.563 1 = 0.625 2 = 0.688 3 = 0.750	4 = 0.813 5 = 0.875 6 = 0.938 7 = 1.000	8 = 1.563 9 = 1.625 A = 1.688 B = 1.750	C = 1.813 D = 1.875 E = 1.938 F = 2.000

**NOTE:**

\*Add 0.5 to values shown for 0-7, if channel is programmed for 5 bits/character.

	BIT 7	BIT 6	BIT 5	BIT 4	BIT 3	BIT 2	BIT 1	BIT 0
	<b>RECEIVER CLOCK SELECT</b>				<b>TRANSMITTER CLOCK SELECT</b>			
CSR	See Text				See Text			

	BIT 7	BIT 6	BIT 5	BIT 4	BIT 3	BIT 2	BIT 1	BIT 0
	<b>MISCELLANEOUS COMMANDS</b>				<b>DISABLE Tx</b>	<b>ENABLE Tx</b>	<b>DISABLE Rx</b>	<b>ENABLE Rx</b>
CR	See Text				0 = no 1 = yes	0 = no 1 = yes	0 = no 1 = yes	0 = no 1 = yes

# Octal Universal Asynchronous Receiver/Transmitter (Octal-UART)

SCC2698

**2**

**Table 2. Register Bit Formats (Continued)**

	BIT 7	BIT 6	BIT 5	BIT 4	BIT 3	BIT 2	BIT 1	BIT 0
	<b>RECEIVED BREAK</b>	<b>FRAMING ERROR</b>	<b>PARITY ERROR</b>	<b>OVERRUN ERROR</b>	<b>TxE<sub>MT</sub></b>	<b>TxRDY</b>	<b>FFULL</b>	<b>RxRDY</b>
SR	0 = no 1 = yes	0 = no 1 = yes	0 = no 1 = yes	0 = no 1 = yes	0 = no 1 = yes	0 = no 1 = yes	0 = no 1 = yes	0 = no 1 = yes

**NOTE:**

\*These status bits are appended to the corresponding data character in the receive FIFO. A read of the status register provides these bits [7:5] from the top of the FIFO together with bits [4:0]. These bits are cleared by a reset error status command. In character mode, they must be reset when the corresponding data character is read from the FIFO.

	BIT 7	BIT 6	BIT 5	BIT 4	BIT 3	BIT 2	BIT 1	BIT 0
	<b>MPO<sub>b</sub> PIN FUNCTION SELECT</b>				<b>POWER-DOWN MODE</b>	<b>MPO<sub>a</sub> PIN FUNCTION SELECT</b>		
OPCR	not used	000 = RTSN 001 = C/TO 010 = TxC (1×) 011 = TxC (16×)	100 = Rx <sub>C</sub> (1×) 101 = Rx <sub>C</sub> (16×) 110 = TxRDY 111 = RxRDY/FF		0 = off 1 = on	000 = RTSN 001 = C/TO 010 = Tx <sub>C</sub> (1×) 011 = Tx <sub>C</sub> (16×)	100 = Rx <sub>C</sub> (1×) 101 = Rx <sub>C</sub> (16×) 110 = TxRDY 111 = RxRDY/FF	

	BIT 7	BIT 6	BIT 5	BIT 4	BIT 3	BIT 2	BIT 1	BIT 0
	<b>BRG SET SELECT</b>	<b>COUNTER/TIMER MODE AND SOURCE</b>			<b>DELTA MPI1<sub>b</sub>INT</b>	<b>DELTA MPI0<sub>b</sub>INT</b>	<b>DELTA MPI1<sub>a</sub>INT</b>	<b>DELTA MPI0<sub>a</sub>INT</b>
ACR	0 = set 1 1 = set 2	See Text			0 = off 1 = on	0 = off 1 = on	0 = off 1 = on	0 = off 1 = on

	BIT 7	BIT 6	BIT 5	BIT 4	BIT 3	BIT 2	BIT 1	BIT 0
	<b>DELTA MPI1<sub>b</sub></b>	<b>DELTA MPI0<sub>b</sub></b>	<b>DELTA MPI1<sub>a</sub></b>	<b>DELTA MPI0<sub>a</sub></b>	<b>MPI1<sub>b</sub></b>	<b>MPI0<sub>b</sub></b>	<b>MPI1<sub>a</sub></b>	<b>MPI0<sub>a</sub></b>
IPCR	0 = no 1 = yes	0 = no 1 = yes	0 = no 1 = yes	0 = no 1 = yes	0 = low 1 = high	0 = low 1 = high	0 = low 1 = high	0 = low 1 = high

	BIT 7	BIT 6	BIT 5	BIT 4	BIT 3	BIT 2	BIT 1	BIT 0
	<b>MPI PORT CHANGE</b>	<b>DELTA BREAK<sub>b</sub></b>	<b>RxRDY/FFULL<sub>b</sub></b>	<b>TxRDY<sub>b</sub></b>	<b>COUNTER READY</b>	<b>DELTA BREAK<sub>a</sub></b>	<b>RxRDY/FFULL<sub>a</sub></b>	<b>TxRDY<sub>a</sub></b>
ISR	0 = no 1 = yes	0 = no 1 = yes	0 = no 1 = yes	0 = no 1 = yes	0 = no 1 = yes	0 = no 1 = yes	0 = no 1 = yes	0 = no 1 = yes

	BIT 7	BIT 6	BIT 5	BIT 4	BIT 3	BIT 2	BIT 1	BIT 0
	<b>MPI PORT CHANGE INT</b>	<b>DELTA BREAK<sub>b</sub> INT</b>	<b>RxRDY/FFULL<sub>b</sub> INT</b>	<b>TxRDY<sub>b</sub> INT</b>	<b>COUNTER READY INT</b>	<b>DELTA BREAK<sub>a</sub> INT</b>	<b>RxRDY/FFULL<sub>a</sub> INT</b>	<b>TxRDY<sub>a</sub> INT</b>
IMR	0 = off 1 = on	0 = off 1 = on	0 = off 1 = on	0 = off 1 = on	0 = off 1 = on	0 = off 1 = on	0 = off 1 = on	0 = off 1 = on

	BIT 7	BIT 6	BIT 5	BIT 4	BIT 3	BIT 2	BIT 1	BIT 0
	<b>C/T[15]</b>	<b>C/T[14]</b>	<b>C/T[13]</b>	<b>C/T[12]</b>	<b>C/T[11]</b>	<b>C/T[10]</b>	<b>C/T[9]</b>	<b>C/T[8]</b>
CTUR								

	BIT 7	BIT 6	BIT 5	BIT 4	BIT 3	BIT 2	BIT 1	BIT 0
	<b>C/T[7]</b>	<b>C/T[6]</b>	<b>C/T[5]</b>	<b>C/T[4]</b>	<b>C/T[3]</b>	<b>C/T[2]</b>	<b>C/T[1]</b>	<b>C/T[0]</b>
CTLR								

# Octal Universal Asynchronous Receiver/Transmitter (Octal-UART)

SCC2698

Input Port Register	BIT 7	BIT 6	BIT 5	BIT 4	BIT 3	BIT 2	BIT 1	BIT 0
	MPI3b	MPI2b	MPI3a	MPI2a	MPI1b	MPI0b	MPI1a	MPI0a
	0 = low	0 = low	0 = low	0 = low	0 = low	0 = low	0 = low	0 = low
	1 = high	1 = high	1 = high	1 = high	1 = high	1 = high	1 = high	1 = high

## CSR — Clock Select Register

### CSR[7:4] — Receiver Clock Select

When using a 3.6864MHz crystal or external clock input, this field selects the baud rate clock for the receiver as shown in Table 3.

The receiver clock is always a 16× clock, except for CSR[7:4] = 1111. When MPI3 is selected as the input, MPI3a is for channel a and MPI3b is for channel b.

### CSR[3:0] — Transmitter Clock Select

This field selects the baud rate clock for the transmitter. The field definition is as shown in Table 3 except as follows.

<b>CSR[3:0]</b>	<b>ACR[7] = 0</b>	<b>ACR[7] = 1</b>
1 1 1 0	MPI2 — 16×	MPI2 — 16×
1 1 1 1	MPI2 — 1×	MPI2 — 1×

When MPI3 is selected as the input, MPI3a is for channel a and MPI3b is for channel b.

## CR — Command Register

CR is used to write commands to the Octal-UART.

### CR[7:4] — Miscellaneous Commands

The encoded value of this field may be used to specify a single command as follows:

- 0000 No command.
- 0001 Reset MR pointer. Causes the MR pointer to point to MR1.
- 0010 Reset receiver. Resets the receiver as if a hardware reset had been applied. The receiver is disabled and the FIFO pointer is reset to the first location.
- 0011 Reset transmitter. Resets the transmitter as if a hardware reset had been applied.
- 0100 Reset error status. Clears the received break, parity error, framing error, and overrun error bits in the status register (SR[7:4]). Used in character mode to clear OE status (although RB, PE, and FE bits will also be cleared), and in block mode to clear all error status after a block of data has been received.
- 0101 Reset break change interrupt. Causes the break detect change bit in the interrupt status register (ISR[2 or 6]) to be cleared to zero.
- 0110 Start break. Forces the TxD output low (spacing). If the transmitter is empty, the start of the break condition

will be delayed up to two bit times. If the transmitter is active, the break begins when transmission of the character is completed. If a character is in the THR, the start of break is delayed until that character or any others loaded after it has been transmitted (TxEMT must be true before break begins). The transmitter must be enabled to start a break.

0111 Stop break. The TxD line will go high (marking) within two bit times. TxD will remain high for one bit time before the next character, if any, is transmitted.

1000 Assert RTSN. Causes the RTSN output to be asserted (low).

1001 Negate RTSN. Causes the RTSN output to be negated (high).

1010 Set special time out mode with this channel as the channel to restart the C/T as each receive character is transferred from shift register to RHR.

1011 Reserved.

1100 Reset special time out mode.

1101 Reserved.

111x Reserved for testing.

### CR[3] — Disable Transmitter

This command terminates transmitter operation and resets the TxRDY and TxEMT status bits. However, if a character is being transmitted or if a character is in the THR when the transmitter is disabled, the transmission of the character(s) is completed before assuming the inactive state.

### CR[2] — Enable Transmitter

Enables operation of the channel a transmitter. The TxRDY status bit will be asserted.

### CR[1] — Disable Receiver

This command terminates operation of the receiver immediately — a character being received will be lost. The command has no effect on the receiver status bits or any other control registers. If the special wake-up mode is programmed, the receiver operates even if it is disabled (see Wake-Up Mode).

### CR[0] — Enable Receiver

Enables operation of the receiver. If not in the special wake-up mode, this also forces the receiver into the search for start bit state.

Table 3. Baud Rate

CSR[7:4]	ACR[7] = 0	ACR[7] = 1
0 0 0 0	50	75
0 0 0 1	110	110
0 0 1 0	134.5	38.4k
0 0 1 1	200	150
0 1 0 0	300	300
0 1 0 1	600	600
0 1 1 0	1,200	1,200
0 1 1 1	1,050	2,000
1 0 0 0	2,400	2,400
1 0 0 1	4,800	4,800
1 0 1 0	7,200	1,800
1 0 1 1	9,600	9,600
1 1 0 0	38.4k	19.2k
1 1 0 1	Timer	Timer
1 1 1 0	MPI3 — 16×	MPI3 — 16×
1 1 1 1	MPI3 — 1×	MPI3 — 1×

## SR — Channel Status Register

### SR[7] — Received Break

This bit indicates that an all-zero character of the programmed length has been received without a stop bit. Only a single FIFO position is occupied when a break is received; further entries to the FIFO are inhibited until the RxDATA line returns to the marking state for at least one-half bit time (two successive edges of the internal or external 1× clock).

When this bit is set, the change in break bit in the ISR (ISR[6 or 2]) is set. ISR[6 or 2] is also set when the end of the break condition, as defined above, is detected. The break detect circuitry is capable of detecting breaks that originate in the middle of a received character. However, if a break begins in the middle of a character, it must last until the end of the next character in order for it to be detected.

### SR[6] — Framing Error (FE)

This bit, when set, indicates that a stop bit was not detected when the corresponding data character in the FIFO was received. The stop bit check is made in the middle of the first stop bit position.

### SR[5] — Parity Error (PE)

This bit is set when the 'with parity' or 'force parity' mode is programmed and the corresponding character in the FIFO was received with incorrect parity. In the special 'wake-up' mode, the parity error bit stores the received A/D bit.

### SR[4] — Overrun Error (OE)

This bit, when set, indicates that one or more characters in the received data stream have



# Octal Universal Asynchronous Receiver/Transmitter (Octal-UART)

SCC2698



been lost. It is set upon receipt of a new character when the FIFO is full and a character is already in the receive shift register waiting for an empty FIFO position. When this occurs, the character in the receive shift register (and its break detect, parity error and framing error status, if any) is lost. This bit is cleared by a reset error status command.

**SR[3] — Transmitter Empty (TxEMT)**

This bit is set when the transmitter underruns, i.e., both the transmit holding register and the transmit shift register are empty. However, this bit is not set until one character has been transmitted. It is set after transmission of the last stop bit of a character, if no character is in the THR awaiting transmission. It is reset when the THR is loaded by the CPU, or when the transmitter is disabled.

**SR[2] — Transmitter Ready (TxRDY)**

This bit, when set, indicates that the THR is empty and ready to be loaded with a character. This bit is cleared when the THR is loaded by the CPU and is set when the character is transferred to the transmit shift register. TxRDY is reset when the transmitter is disabled and is set when the transmitter is first enabled, e.g., characters loaded in the THR while the transmitter is disabled will not be transmitted.

**SR[1] — FIFO Full (FFULL)**

This bit is set when a character is transferred from the receive shift register to the receive FIFO and the transfer causes the FIFO to become full, i.e., all three FIFO positions are occupied. It is reset when the CPU reads the FIFO and there is no character in the receive shift register. If a character is waiting in the receive shift register because the FIFO is full, FFULL is not reset after reading the FIFO once.

**SR[0] — Receiver Ready (RxRDY)**

This bit indicates that a character has been received and is waiting in the FIFO to be read by the CPU. It is set when the character is transferred from the receive shift register to the FIFO and reset when the CPU reads the RHR, and no more characters are in the FIFO.

**OPCR — Output Port Configuration Register**

**OPCR[6:4] — MPOb Output Select**

This field programs the MPOb output pin to provide one of the following:

- 000 Request-to-send active low output (RTSN). This output is asserted and negated via the command register. Mode RTSN can be programmed to be automatically reset after the character in the transmitter is completely shifted out or when the receiver FIFO and receiver shift register are full

using MR2[5] and MR1[7], respectively.

- 001 The counter/timer output. In the timer mode, this output is a square wave with a period of twice the value (in clock periods) of the contents of the CTUR and CTLR. In the counter mode, the output remains high until the terminal count is reached, at which time it goes low. The output returns to the high state when the counter is stopped by a stop counter command.
- 010 The 1× clock for the transmitter, which is the clock that shifts the transmitted data. If data is not being transmitted, a non-synchronized 1× clock is output.
- 011 The 16× clock for the transmitter. This is the clock selected by CSR[3:0], and is a 1× clock if CSR[3:0] = 1111.
- 100 The 1× clock for the receiver, which is the clock that samples the received data. If data is not being received, a non-synchronized 1× clock is output.
- 101 The 16× clock for the receiver. This is the clock selected by CSR[7:4], and is a 1× clock if CSR[7:4] = 1111.
- 110 The transmitter register empty signal, which is the same as SR[3].
- 111 The receiver ready or FIFO full signal.

**OPCR[3] — Power-Down Mode Select**

This bit, when set, selects the power-down mode. In this mode, the SCC2698 oscillator is stopped and all functions requiring this clock are suspended. The contents of all registers are saved. It is recommended that the transmitter and receiver be disabled prior to placing the SCC2698 in this mode. This bit is reset with RESET asserted. Note that this bit must be set to a logic 1 before power-down occurs. Only OPCR[3] in block A controls the power-down mode.

**OPCR[2:0] — MPOa Output Select**

This field programs the MPOa output pin to provide one of the same functions as described in OPCR[6:4].

**ACR — Auxiliary Control Register**

**ACR[7] — Baud Rate Generator Set Select**

This bit selects one of two sets of baud rates to be generated by the BRG.

Set 1: 50, 110, 134.5, 200, 300, 600, 1.05k, 1.2k, 2.4k, 4.8k, 7.2k, 9.6k, and 38.4k baud.

Set 2: 75, 110, 38.4k, 150, 300, 600, 1.2k, 1.8k, 2.0k, 2.4k, 4.8k, 9.6k and 19.2k baud.

The selected set of rates is available for use by the receiver and transmitter.

**ACR[6:4] — Counter/Timer Mode and Clock Source Select**

This field selects the operating mode of the counter/timer and its clock source (see Table 4).

The MPI pin available as the clock source is MPI a, c, e, and g only.

**ACR[3:0] — MPI1b, MPI0b, MPI1a, MPI0a Change-of-State Interrupt Enable**

This field selects which bits of the input port change register (IPCR) cause the input change bit in the interrupt status register, ISR[7], to be set. If a bit is in the 'on' state, the setting of the corresponding bit in the IPCR will also result in the setting of ISR[7], which results in the generation of an interrupt output if IMR[7] = 1. If a bit is in the 'off' state, the setting of that bit in the IPCR has no effect on ISR[7].

**IPCR — Input Port Change Register**

**IPCR[7:4] — MPI1b, MPI0b, MPI1a, MPI0a Change-of-State**

These bits are set when a change-of-state, as defined in the Input Port section of this data sheet, occurs at the respective pins. They are cleared when the IPCR is read by the CPU. A read of the IPCR also clears ISR[7], the input change bit in the interrupt status register. The setting of these bits can be programmed to generate an interrupt to the CPU.

**IPCR[3:0] — MPI1b, MPI0b, MPI1a, MPI0a Change-of-State**

These bits provide the current state of the respective inputs. The information is un-latched and reflects the state of the input pins at the time the IPCR is read.

**Table 4. ACR[6:4] Operating Mode**

[6:4]	MODE	CLOCK SOURCE
0 0 0	Counter	MPI pin
0 0 1	Counter	MPI pin divided by 16
0 1 0	Counter	TxC—1× clock of the transmitter
0 1 1	Counter	Crystal or external clock (X1/CLK) divided by 16
1 0 0	Timer	MPI pin
1 0 1	Timer	MPI pin divided by 16
1 1 0	Timer	Crystal or external clock (X1/CLK)
1 1 1	Timer	Crystal or external clock (X1/CLK) divided by 16

# Octal Universal Asynchronous Receiver/Transmitter (Octal-UART)

## SCC2698

### ISR — Interrupt Status Register

This register provides the status of all potential interrupt sources. The contents of this register are masked by the interrupt mask register (IMR). If a bit in the ISR is a '1' and the corresponding bit in the IMR is also a '1', the INTRN output is asserted (low). If the corresponding bit in the IMR is a zero, the state of the bit in the ISR has no effect on the INTRN output. Note that the IMR does not mask the reading of the ISR — the true status is provided regardless of the contents of the IMR.

#### ISR[7] — MPI Change-of-State

This bit is set when a change-of-state occurs at the MPI1b, MPI0b, MPI1a, MPI0a input pins. It is reset when the CPU reads the IPCR.

#### ISR[6] — Channel b Change in Break

This bit, when set, indicates that the receiver has detected the beginning or the end of a received break. It is reset when the CPU issues a reset break change interrupt command.

#### ISR[5] — Receiver Ready or FIFO Full Channel b

The function of this bit is programmed by MR1[6]. If programmed as receiver ready, it indicates that a character has been received and is waiting in the FIFO to be read by the CPU. It is set when the character is transferred from the receive shift register to the FIFO and reset when the CPU reads the receive FIFO. If the FIFO contains more characters, the bit will be set again after the FIFO is read.

If programmed as FIFO full, it is set when a character is transferred from the receive shift register to the receive FIFO and the transfer causes the FIFO to become full, i.e., all three FIFO positions are occupied. It is reset when FIFO is read and there is no character in the receive shift register. If there is a character waiting in the receive shift register because the FIFO is full, the bit is set again when the waiting character is transferred into the FIFO.

#### ISR[4] — Transmitter Ready Channel b

This bit is a duplicate of TxRDY (SR[2]).

#### ISR[3] — Counter Ready

In the counter mode of operation, this bit is set when the counter reaches terminal count and is reset when the counter is stopped by a

stop counter command. It is initialized to '0' when the chip is reset.

In the timer mode, this bit is set once each cycle of the generated square wave (every other time the C/T reaches zero count). The bit is reset by a stop counter command. The command, however, does not stop the C/T.

#### ISR[2] — Channel a Change in Break

This bit, when set, indicates that the receiver has detected the beginning or the end of a received break. It is reset when the CPU issues a reset break change interrupt command.

#### ISR[1] — Receiver Ready or FIFO Full Channel a

The function of this bit is programmed by MR1[6]. If programmed as receiver ready, it indicates that a character has been received and is waiting in the FIFO to be read by the CPU. It is set when the character is transferred from the receive shift register to the FIFO and reset when the CPU reads the receive FIFO. If the FIFO contains more characters, the bit will be set again after the FIFO is read. If programmed as FIFO full, it is set when a character is transferred from the receive shift register to the receive FIFO and the transfer causes the FIFO to become full, i.e., all three FIFO positions are occupied. It is reset when FIFO is read and there is no character in the receiver shift register. If there is a character waiting in the receive shift register because the FIFO is full, the bit is set again when the waiting character is transferred into the FIFO.

#### ISR[0] — Transmitter Ready Channel a

This bit is a duplicate of TxRDY (SR[2]).

### IMR — Interrupt Mask Register

The programming of this register selects which bits in the ISR cause an interrupt output. If a bit in the ISR is a '1' and the corresponding bit in the IMR is a '1', the INTRN output is asserted (low). If the corresponding bit in the IMR is a zero, the state of the bit in the ISR has no effect on the INTRN output. Note that the IMR does not mask reading of the ISR.

### CTUR and CTLR — Counter/Timer Registers

The CTUR and CTLR hold the eight MSBs and eight LSBs, respectively, of the value to

be used by the counter/timer in either the counter or timer modes of operation. The minimum value which may be loaded is 0002<sub>16</sub>.

In the timer (programmable-divider) mode, the C/T generates a square wave with a period of twice the value (in clock periods) of the CTUR and CTLR. If the value in CTUR or CTLR is changed, the current half-period will not be affected, but subsequent half-periods will be. In this mode the C/T runs continuously. Receipt of a start counter command causes the counter to begin a new cycle using the values in CTU and CTL. The counter ready status bit, ISR[3], is set once each cycle of the square wave. The bit is reset by a stop counter command. The command, however, does not stop the C/T.

The generated square wave is output on MPO if it is programmed to be the C/T output.

In the counter mode, the C/T counts down the number of pulses loaded into CTUR and CTLR. Counting begins upon receipt of a start counter command. Upon reaching the terminal count, the counter ready interrupt bit, ISR[3], is set. The counter continues counting past the terminal count until stopped by the CPU. If MPO is programmed to be the output of the C/T, the output remains high until the terminal count is reached, at which time it goes low.

The output returns to the high state and ISR[3] is cleared when the counter is stopped by a stop counter command. The CPU may change the values of CTUR and CTLR at any time, but the new count becomes effective only on the next start counter command. If new values have not been loaded, the previous count values are preserved and used for the next count cycle.

In the counter mode, the current value of the upper and lower eight bits of the counter can be read by the CPU. It is recommended that the counter be stopped when reading to prevent potential problems which may occur if a carry from the lower eight bits to the upper eight bits occurs between the times that both halves of the counter are read. However, a subsequent start counter command causes the counter to begin a new count cycle using the values in CTUR and CTLR.

# Octal Universal Asynchronous Receiver/Transmitter (Octal-UART)

SCC2698

**ABSOLUTE MAXIMUM RATINGS<sup>1</sup>**

SYMBOL	PARAMETER	RATING	UNIT
T <sub>A</sub>	Operating ambient temperature <sup>2</sup> range	0 to +70	°C
T <sub>STG</sub>	Storage temperature range	-65 to +150	°C
V <sub>CC</sub>	Voltage from V <sub>CC</sub> to GND <sup>3</sup>	-0.5 to +7.0	V
V <sub>S</sub>	Voltage from any pin to ground <sup>3</sup>	-0.5 to V <sub>CC</sub> ±5%	V
P <sub>D</sub>	Power dissipation	1	W

**DC ELECTRICAL CHARACTERISTICS** T<sub>A</sub> = 0°C to +70°C, V<sub>CC</sub> = +5V ±5%<sup>4, 5, 6</sup>

SYMBOL	PARAMETER	TEST CONDITIONS	LIMITS			UNIT
			Min	Typ	Max	
V <sub>IL</sub>	Input low voltage				0.8	V
V <sub>IH</sub>	Input high voltage (except X1/CLK)		2			V
V <sub>IH</sub>	Input high voltage (X1/CLK)		0.9V <sub>CC</sub>	V <sub>CC</sub>		V
V <sub>OL</sub>	Output low voltage	I <sub>OL</sub> = 2.4mA			0.4	V
V <sub>OH</sub>	Output high voltage (except OC outputs)	I <sub>OH</sub> = -400μA	2.4			V
I <sub>IL</sub>	Input leakage current	V <sub>IN</sub> = 0 to V <sub>CC</sub>	-10		10	μA
I <sub>LL</sub>	Data bus 3-State leakage current	V <sub>O</sub> = 0 to V <sub>CC</sub>	-10		10	μA
I <sub>X1L</sub>	X1/CLK low input current	V <sub>IN</sub> = 0, X2 floated	-3	-1.5	0	mA
I <sub>X1H</sub>	X1/CLK high input current	V <sub>IN</sub> = V <sub>CC</sub> , X2 floated	0	3.5	10	mA
I <sub>X2L</sub>	X2 low input current	V <sub>IN</sub> = 0, X1/CLK floated	-100	-30	0	μA
I <sub>X2H</sub>	X2 high input current	V <sub>IN</sub> = V <sub>CC</sub> , X1/CLK floated	0	+30	100	μA
I <sub>OC</sub>	Open-collector output leakage current	V <sub>O</sub> = 0 to V <sub>CC</sub>			10	μA
I <sub>CC</sub>	Power supply current				150	mA

**NOTES:**

- Stresses above those listed under Absolute Maximum Ratings may cause permanent damage to the device. This is a stress rating only and functional operation of the device at these or any other condition above those indicated in the operation section of this specification is not implied.
- For operating at elevated temperatures, the device must be derated based on +150°C maximum junction temperature.
- This product includes circuitry specifically designed for the protection of its internal devices from damaging effects of excessive static charge. Nonetheless, it is suggested that conventional precautions be taken to avoid applying any voltages larger than the rated maxima.
- Parameters are valid over specified temperature range.
- All voltage measurements are referenced to ground (GND). For testing, all inputs except X1/CLK swing between 0.4V and 2.4V with a transition time of 20ns maximum. For X1/CLK this swing is between 0.4V and 4.4V. All time measurements are referenced at input voltages of 0.8V and 2V, as appropriate.
- Typical values are at +25°C, typical supply voltages, and typical processing parameters.

# Octal Universal Asynchronous Receiver/Transmitter (Octal-UART)

## SCC2698

### AC ELECTRICAL CHARACTERISTICS $T_A = 0^\circ\text{C}$ to $+70^\circ\text{C}$ , $V_{CC} = +5\text{V} \pm 5\%$ <sup>4, 5, 6, 7</sup>

SYMBOL	PARAMETER	TENTATIVE LIMITS			UNIT
		Min	Typ	Max	
<b>Reset timing (Figure 2)</b>					
$t_{RES}$	RESET pulse width		1.0		$\mu\text{s}$
<b>Bus timing (Figure 3)<sup>8</sup></b>					
$t_{AS}$	A0 – A5 setup time to RDN, WRN low	10			ns
$t_{AH}$	A0 – A5 hold time from RDN, WRN high	0			ns
$t_{CS}^9$	CEN setup time to RDN, WRN low	0			ns
$t_{CH}^9$	CEN hold time from RDN, WRN high	0			ns
$t_{RW}$	WRN, RDN pulse width	225			ns
$t_{DD}$	Data valid after RDN low			150	ns
$t_{DF}$	Data bus floating after RDN high			100	ns
$t_{DS}$	Data setup time before WRN high	100			ns
$t_{DH}$	Data hold time after WRN high	10			ns
$t_{RWD}^{10}$	High time between reads and/or writes	200			ns
<b>MPI and MPO timing (Figure 4)<sup>8</sup></b>					
$t_{PS}$	MPI input setup time before RDN low	0			ns
$t_{PH}$	MPI input hold time after RDN high	0			ns
$t_{PD}$	MPO output valid after WRN high			370	ns
<b>Interrupt timing (Figure 5)</b>					
$t_{IR}$	INTRN high from:				
	Read RHR (RxRDY/FFULL interrupt)			270	ns
	Write THR (TxRDY, TxEMT interrupt)			270	ns
	Reset command (break change interrupt)			270	ns
	Reset command (MPI change interrupt)			270	ns
	Stop C/T command (counter interrupt)			270	ns
	Write IMR (clear of interrupt mask bit)			270	ns
<b>Clock timing (Figure 6)</b>					
$t_{CLK}$	X1/CLK high or low time	100			ns
$f_{CLK}$	X1/CLK frequency	2.0	3.6864	4	MHz
$t_{CTC}$	CTCLK high or low time	100			ns
$f_{CTC}$	CTCLK frequency	0		4	MHz
$t_{RX}$	RxC high or low time	220			ns
$f_{RX}$	RxC frequency ( $16\times$ )	0		2	MHz
	( $1\times$ )	0		1	MHz
$t_{TX}$	TxC high or low time	220			ns
$f_{TX}$	TxC frequency ( $16\times$ )	0		2	MHz
	( $1\times$ )	0		1	MHz
<b>Transmitter timing (Figure 7)</b>					
$t_{TXD}$	TxD output delay from TxC low			350	ns
$t_{TCS}$	TxC output delay from TxD output data	0		150	ns
<b>Receiver timing (Figure 8)</b>					
$t_{RXS}$	RxD data setup time to RxC high	200			ns
$t_{RXH}$	RxD data hold time from RxC high	200			ns

#### NOTES:

- Test condition for outputs:  $C_L = 150\text{pF}$ , except interrupt outputs. Test condition for interrupt outputs:  $C_L = 50\text{pF}$ ,  $R_L = 2.7\text{k}\Omega$  to  $V_{CC}$ .
- Timing is illustrated and referenced to the WRN and RDN inputs. The device may also be operated with CEN as the 'strobing' input. In this case, all timing specifications apply referenced to the falling and rising edges of CEN. CEN and RDN (also CEN and WRN) are ANDed internally. As a consequence, the signal asserted last initiates the cycle and the signal negated first terminates the cycle.
- If CEN is used as the 'strobing' input, the parameter defines the minimum high times between one CEN and the next. The RDN signal must be negated for  $t_{RWD}$  to guarantee that any status register changes are valid.
- Consecutive write operations to the same command register require at least three edges of the X1 clock between writes.

# Octal Universal Asynchronous Receiver/Transmitter (Octal-UART)

SCC2698

2

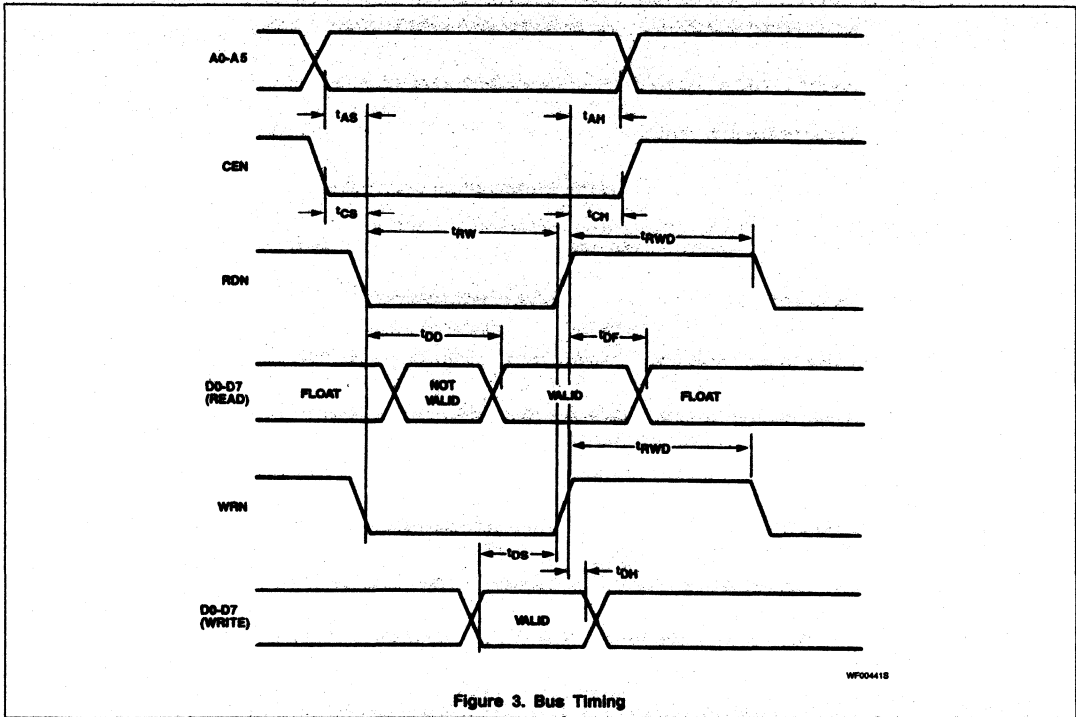
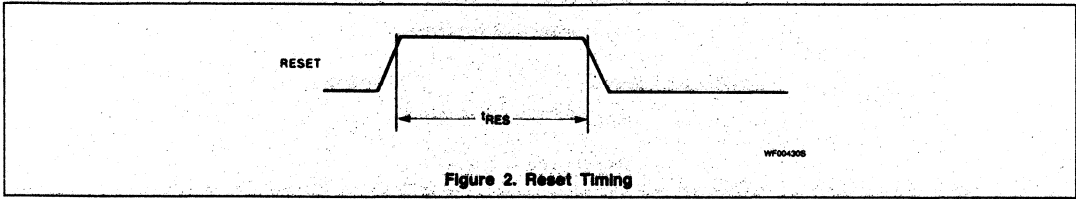

# Octal Universal Asynchronous Receiver/Transmitter (Octal-UART)

## SCC2698

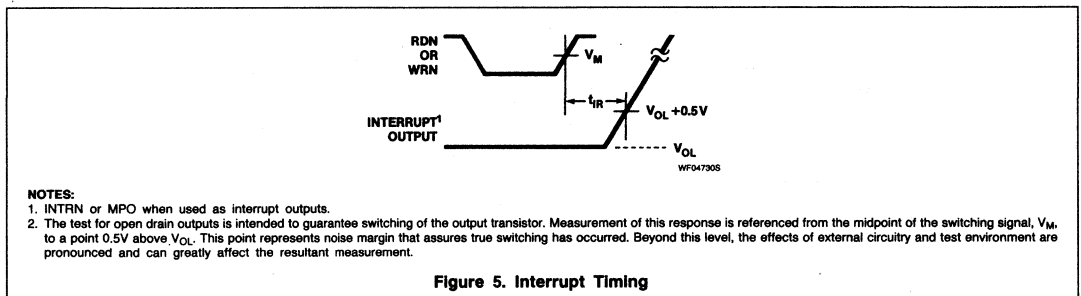
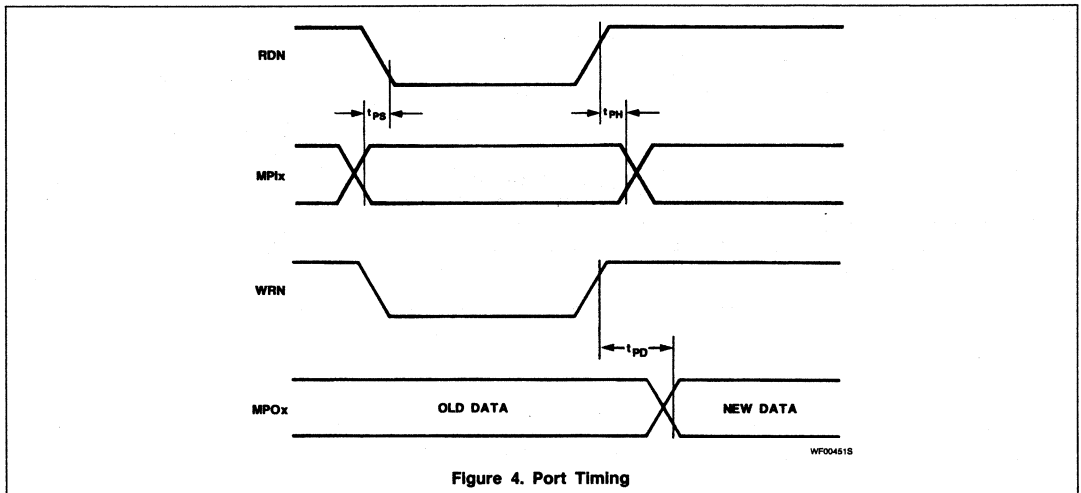

**NOTES:**

1. INTRN or MPO when used as interrupt outputs.
2. The test for open drain outputs is intended to guarantee switching of the output transistor. Measurement of this response is referenced from the midpoint of the switching signal,  $V_M$ , to a point  $0.5V$  above  $V_{OL}$ . This point represents noise margin that assures true switching has occurred. Beyond this level, the effects of external circuitry and test environment are pronounced and can greatly affect the resultant measurement.

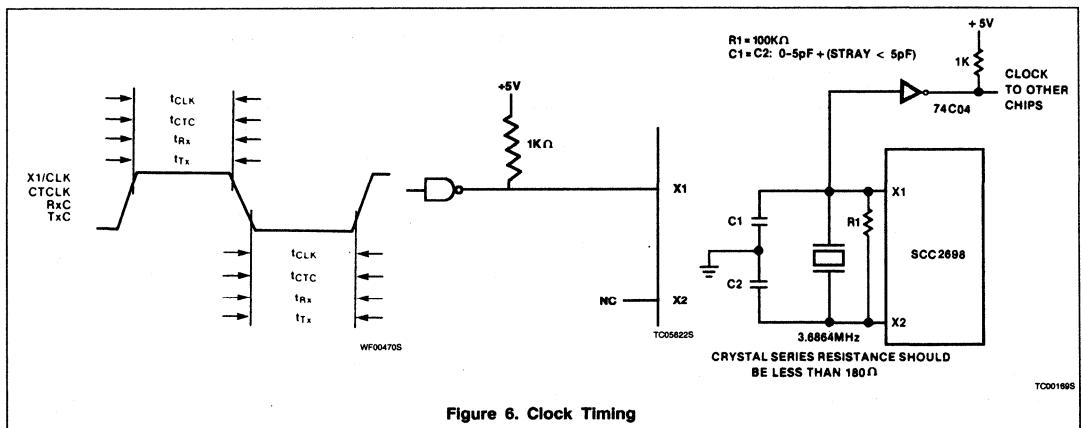

# Octal Universal Asynchronous Receiver/Transmitter (Octal-UART)

SCC2698

**2**

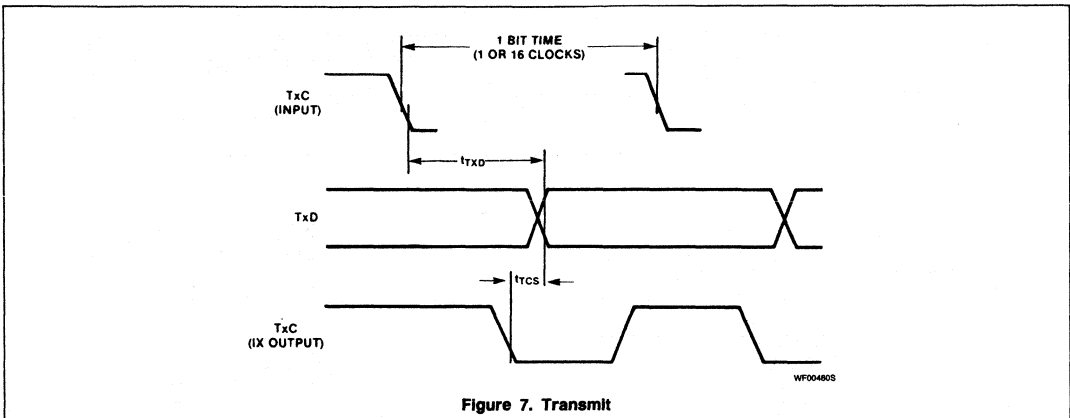

Figure 7. Transmit

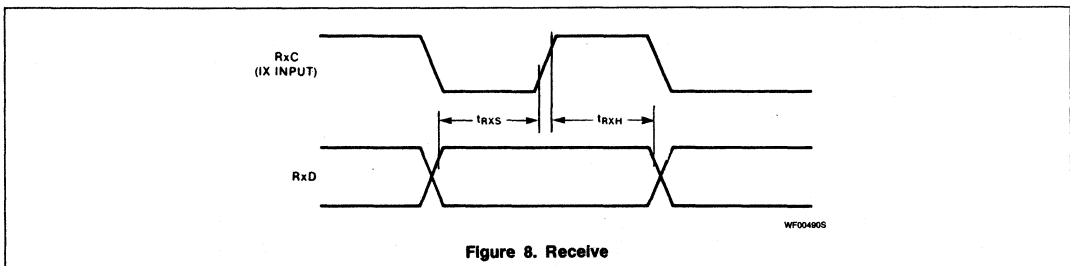
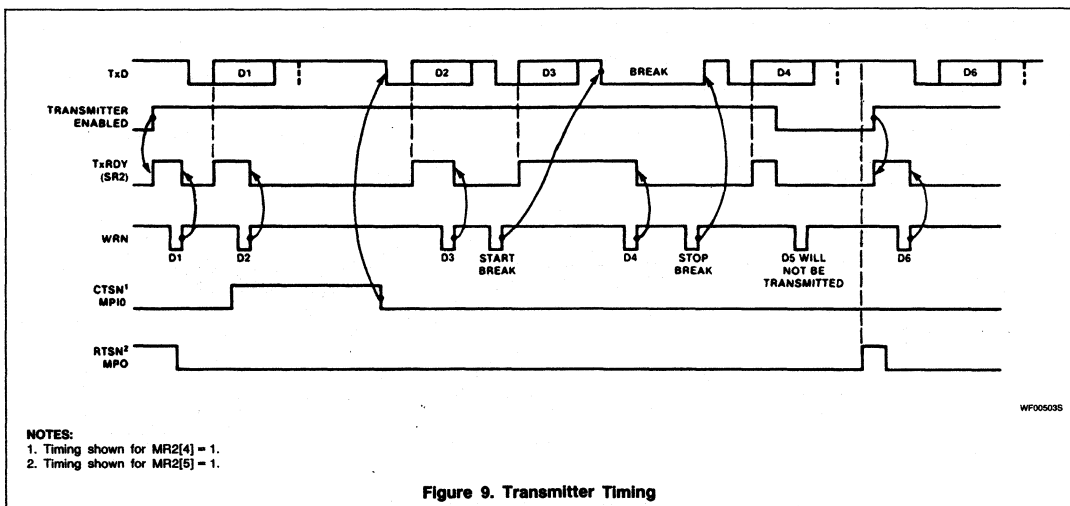

Figure 8. Receive



- NOTES:  
 1. Timing shown for MR2[4] = 1.  
 2. Timing shown for MR2[5] = 1.

Figure 9. Transmitter Timing

# Octal Universal Asynchronous Receiver/Transmitter (Octal-UART)

SCC2698

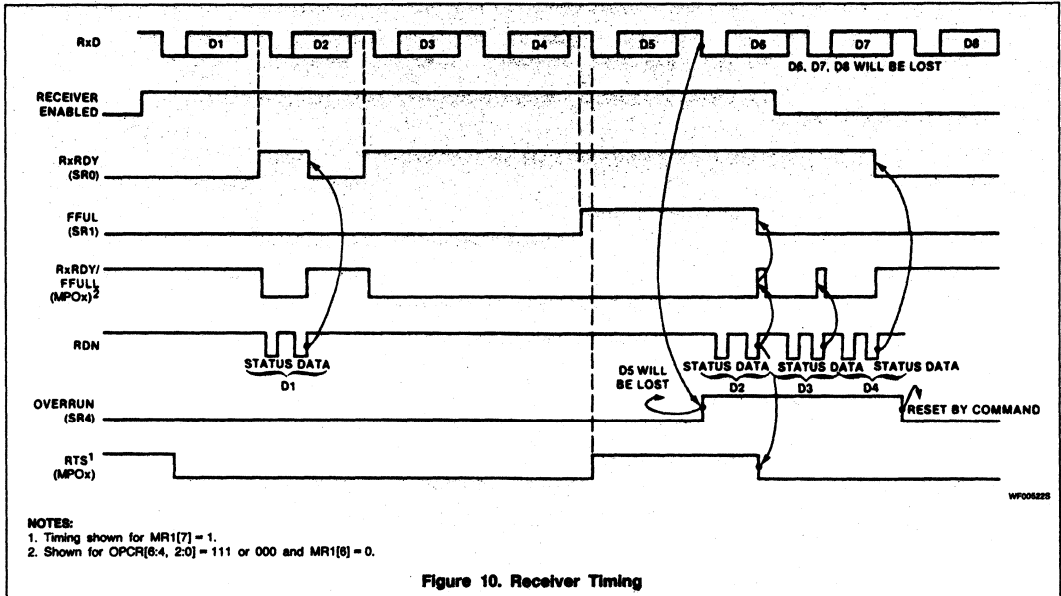

Figure 10. Receiver Timing

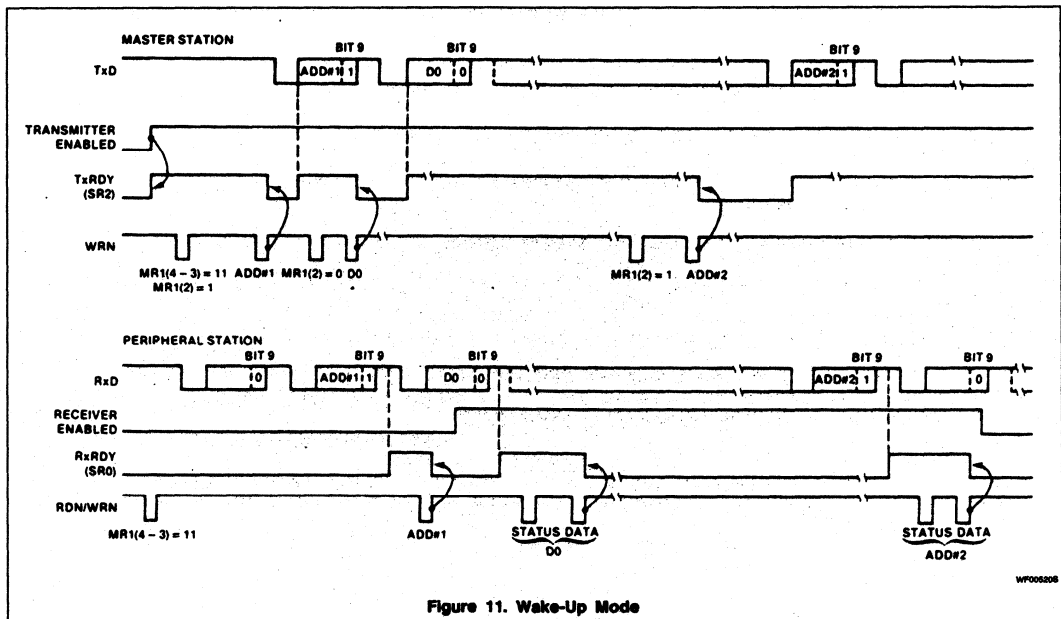

Figure 11. Wake-Up Mode



# SCC63484

## Advanced CRT Controller (ACRTC)

*Preliminary Specification*

### Microprocessor Products

#### DESCRIPTION

The Signetics SCC63484 Advanced CRT Controller (ACRTC) is a CMOS VLSI microcomputer peripheral device capable of controlling raster scan type CRTs to display both graphics and characters. The ACRTC is a new generation CRT controller that is based on a bit-mapped technology and has more display control functions than those of an SCN2674 Advanced Video Display Controller (AVDC).

The ACRTC prepares the mechanisms to use in one of three modes: character only; graphic only and multiplexed character/graphic modes. Therefore, the ACRTC can be applied to many applications, from character-only display devices to large full-graphic systems.

The ACRTC can reduce CPU software overhead and enhance system throughput.

#### FEATURES

- **High-speed graphic drawings**
  - Drawing rate: maximum 500ns/pixel (color drawing)
  - Drawn graphics: Dot, line, rectangle, polyline, polygon, circle, ellipse, paint, copy, etc.
  - Drawn colors: 16 bits/word, 1, 2, 4, 8, 16 bits/pixel (5 types) monochrome to max 64k colors
- **Large frame memory space**
  - Maximum 2Mbytes graphic memory
  - Maximum 128k-byte character memory separated from the MPU memory
  - Available to maximum 4096 X 4096 high-resolution CRT (1 bit/pixel mode)
- **Various CRT display controls**
  - Split screens (3 displays and 1 window)
  - Zooming up (1 to 16 times)
  - Scroll (vertical and horizontal)
- **External synchronization**
  - Synchronization between ACRTCs or between the ACRTC and external device; e.g. TV system or other controller
- **DMA interface**
- **Two programmable cursors**
- **Three scan modes**
  - Non-interlace, interlace sync., and interlace sync. and video modes
- **Interrupt request to MPU**
- **256 characters/line, 32 rasters/line, 4096 rasters/screen**
- **Maximum clock frequency 8MHz**
- **CMOS, +5V single power supply**

#### PIN CONFIGURATION

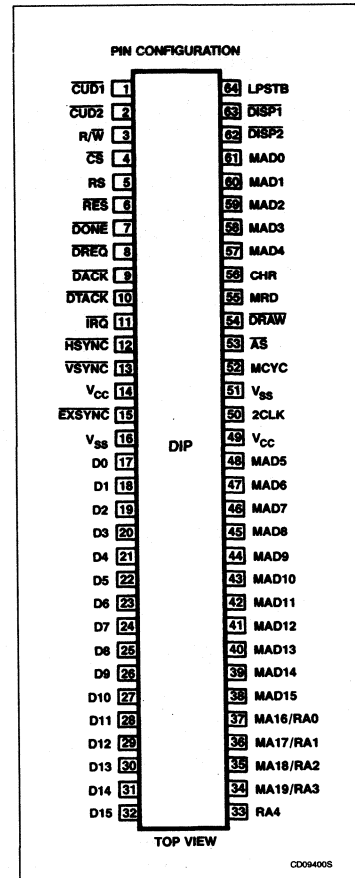

# Advanced CRT Controller (ACRTC)

# SCC63484

## ORDERING INFORMATION

PACKAGE	$V_{CC} = 5V \pm 5\%$ , $T_A = 0^\circ C$ to $+70^\circ C$	
	8MHz	
Plastic DIP	SCC63484C8N64	
Ceramic DIP	SCC63484C8I64	
Plastic LCC	SCC63484C8A68	

## BLOCK DIAGRAM

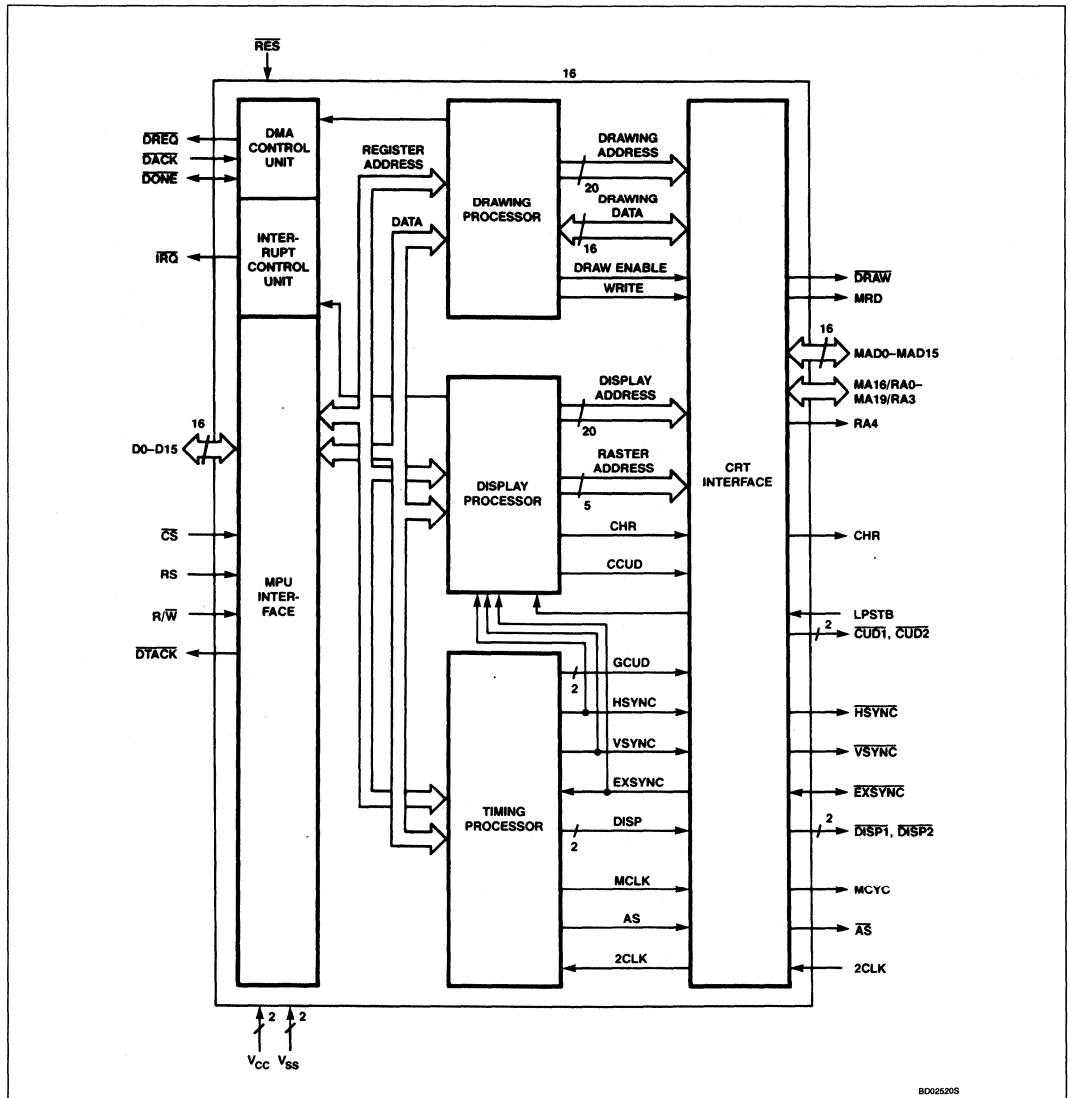

## Advanced CRT Controller (ACRTC)

SCC63484

2

## PIN DESCRIPTION

MNEMONIC	PIN NO.	TYPE	NAME AND FUNCTION
<b>MPU interface</b>			
$\overline{RES}$	6	I	<b>Reset:</b> Hardware reset to the ACRTC.
D0 – D15	17 – 32	I/O	<b>Data Bus:</b> The bidirectional data bus for communication with the host MPU or DMAC. In 8-bit data bus mode, D0 – D7 are used.
R/ $\overline{W}$	3	I	<b>Read/Write:</b> Controls the direction of host to/from ACRTC transfers.
$\overline{CS}$	4	I	<b>Chip Select:</b> Enables data transfers between the host and the ACRTC.
RS	5	I	<b>Register Select:</b> Selects the ACRTC register to be accessed and is normally connected to the least significant bit of the host address bus.
$\overline{DTACK}$	10	O	<b>Data Transfer Acknowledge:</b> Provides asynchronous bus cycle timing and is compatible with the SCN68000 Microprocessor $\overline{DTACK}$ input.
$\overline{IRQ}$	11	O	<b>Interrupt Request:</b> Generates interrupt service requests to the host MPU.
<b>DMAC interface</b>			
$\overline{DREQ}$	8	O	<b>DMA Request:</b> Generates DMA service requests to the host DMAC.
$\overline{DACK}$	9	I	<b>DMA Acknowledge:</b> Receives DMA acknowledge timing from the host DMAC.
$\overline{DONE}$	7	I/O	<b>Done:</b> Terminates DMA transfer and is compatible with the DMAC $\overline{DONE}$ signal.
<b>CRT interface</b>			
2CLK	50	I	<b>Clock:</b> Basic ACRTC operating clock derived from the dot clock.
MAD0 – MAD15	61 – 57, 48 – 38	I/O	<b>Address/Data Bus:</b> Multiplexed frame buffer address/data bus.
$\overline{AS}$	53	O	<b>Address Strobe:</b> Address strobe for demultiplexing the frame buffer address/data bus (MAD0 – MAD15).
MA16/RA0 – MA19/RA3	37 – 34	O	<b>Address Bits/Raster Address Outputs:</b> The high-order address bits for graphic screens and the raster address outputs for character screens.
RA4	33	O	<b>Raster Address Bit:</b> Provides the high-order raster address bit (up to 32 rasters) for character screens.
CHR	56	O	<b>Graphic/Character Screen Access:</b> Indicates whether a graphic or character screen is being accessed.
MCYC	52	O	<b>Memory Clock:</b> Frame buffer memory access timing — one half the frequency of 2CLK.
MRD	55	O	<b>Bus Direction Control:</b> Frame buffer data bus direction control.
$\overline{DRAW}$	54	O	<b>Drawing/Refresh Cycle:</b> Differentiates between drawing cycles and CRT display refresh cycles.
$\overline{DISPT}$ – $\overline{DISP2}$	62 – 63	O	<b>Display Enable Timing:</b> Programmable display enable timing used to selectively enable, disable and blank logical screens.
$\overline{CUD1}$ – $\overline{CUD2}$	1 – 2	O	<b>Cursor Timing:</b> Provides cursor timing determined by ACRTC programmed parameters such as cursor definition, cursor mode, cursor address, etc.
$\overline{VSYNC}$	13	O	<b>Vertical Synchronization:</b> CRT device vertical synchronization pulse.
$\overline{HSYNC}$	12	O	<b>Horizontal Synchronization:</b> CRT device horizontal synchronization pulse.
$\overline{EXSYNC}$	15	I/O	<b>External Synchronization:</b> For synchronization between multiple ACRTCs and other video signal generating devices.
LPSTB	64	I	<b>Light Pen:</b> Connection to an external light pen.

**BLOCK DIAGRAM**

The ACRTC consists of five major functional blocks. These functional blocks operate in parallel to achieve maximum performance. Two of the blocks perform the external bus interface for the host MPU and CRT, respectively.

**MPU Interface**

The MPU interface manages the asynchronous host MPU interface including the programmable interrupt control unit and DMA handshaking control unit.

**CRT Interface**

The CRT interface manages the frame buffer bus and CRT timing input and output control signals. Also, the selection of either display refresh address or drawing address outputs is performed. The other three blocks are separately microprogrammed processors which

# Advanced CRT Controller (ACRTC)

SCC63484

operate in parallel to perform the major functions of drawing, display control, and timing.

### Drawing Processor

This interprets commands and command parameters issued by the host bus (MPU and/or DMAC) and performs the drawing operations on the frame buffer memory. This processor is responsible for the execution of ACRTC drawing algorithms and conversion of logical pixel X-Y addresses to physical frame buffer addresses. Communication with the host bus is from separate 16-byte read and write FIFOs.

### Display Processor

The display processor manages frame buffer refresh addressing based on the user-programmed specification of display screen organization. Combines and displays as many as four independent screen segments (three horizontal splits and one window) using an internal high-speed address calculation unit. Controls display refresh address outputs based on graphic (physical frame buffer address) or character (physical frame buffer address + row address) display modes.

### Timing Processor

This generates the CRT synchronization signals and other timing signals used internally by the ACRTC. The ACRTC's software visible registers are similarly partitioned and reside in the appropriate internal processor, depending on function. The registers in the display and timing processors are loaded with basic display parameters during system initialization. During operation, the host primarily communicates with the ACRTC's drawing processor via the on-chip FIFOs.

## OPERATION

Powerful visual interfaces are a key component of advanced system architectures. A proven technique uses raster-scanned CRT technology for the display of graphics and text information.

Systems which use first-generation CRT controllers (CRTC) are constrained by hardware/software design time, manufacturing cost, and limited MPU bandwidth. To meet the functional requirements for powerful visual interfaces and to support their use in high volume, cost-sensitive applications, advanced circuit design and VLSI CMOS manufacturing technologies have been used to create a next generation CRTC, the SCC63484 ACRTC. The ACRTC concept is to incorporate major functionality on-chip, formerly requiring external hardware and software. In this way, both higher performance and reduced system cost benefits are achieved.

1. High-level command language increases performance and reduces software development cost.
  - ACRTC converts logical X-Y coordinates to physical frame buffer addresses
  - 38 commands including 23 graphic drawing commands — LINE, RECTANGLE, POLYLINE, POLYGON, CIRCLE, ELLIPSE, ARC, ELLIPSE ARC, FILLED RECTANGLE, PAINT, PATTERN and COPY
  - On-chip 32-byte pattern RAM
  - Conditional drawing function (8 conditions) for drawing patterns, color mixing and software mixing and software windowing
  - Drawing area control with hardware clipping and hitting
  - Maximum drawing speed of 2 million logical pixels per second is the same for monochrome and color applications
2. High resolution display with advanced screen control
  - Up to 4096 by 4096 bit map graphic display and/or 256 line by 256 character by 32 raster character display
  - Separate bit map graphic (2Mbyte) and character (128kbyte) address spaces with combined graphic/character display
  - Three horizontal split screens and one window screen
  - Size and position fully programmable
  - Independent horizontal and vertical smooth scroll for each screen
  - 1 to 16 zoom magnitude — independent X and Y zoom factors
- Logical pixel specification as 1, 2, 4, 8 or 16 bits for monochrome, gray scale and color displays
- Programmable address increment supports frame buffer memory widths to 256 bits for video bit rates > 500MHz. (ACRTC R mask is limited to 128 bits)
- Unique interleaved access mode for screen superimposition or 'flashless' displays
- ACRTC provides dynamic RAM refresh address
3. High-performance MPU interface
  - Optimized interface with the SCN68000 MPU and DMAC
  - 8- or 16-bit bus — compatible with other MPUs
  - Separate on-chip 16-byte read and write FIFOs
  - Maskable interrupts including FIFO status
4. Versatile CRT interface
  - Full programmability of CRT timing signals
  - Three raster scanning modes
  - Master or slave synchronization to multiple ACRTCs or other video generating devices
  - Two hardware cursors; three cursor modes
  - Programmable cursor and display timing skew
  - Eight user-definable video attributes
  - Light pen detection
5. VLSI CMOS process

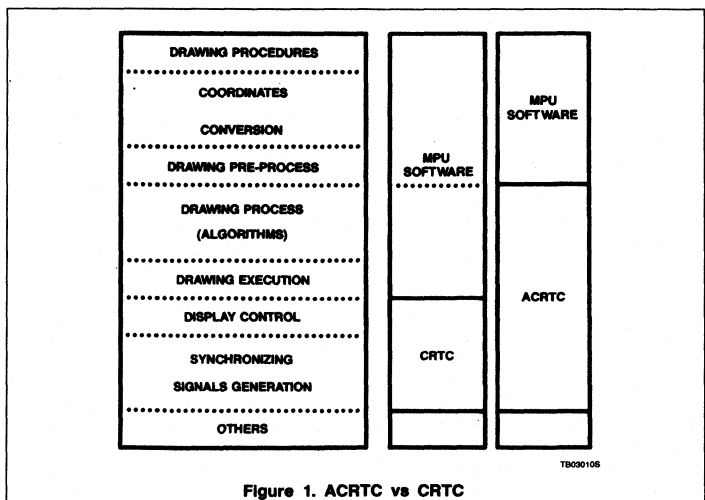

Figure 1. ACRTC vs CRTC

# Advanced CRT Controller (ACRTC)

SCC63484

2

## APPLICATIONS

The overall function of a visual interface is logically partitioned into layers. At the lowest layer are CRT timing and control signal generation. At the top layer are general purpose drawing procedures which provide a high-level interface to the user's operating system or application software. At this layer, a number of popular standards have emerged including GKS, CORE, NAPLP, GSX and others.

Figure 1 shows how the ACRTC performs the key functions or logical drawing algorithm and physical drawing execution. Formerly, these functions were performed by external hardware and/or MPU software.

As shown, the ACRTC reduces the 'gap' between device functionality and high-level graphics procedures. Since the ACRTC device itself provides capabilities closely related to those of high-level graphics packages, the effort (hardware and software design time and cost) required to develop a visual interface is significantly reduced.

Noting the traditional and emerging applications for visual interfaces, Figure 2 shows that a single ACRTC is suitable for a broad range of products in both alphanumeric and graphics areas. Multiple ACRTCs can achieve performance beyond that of any first-generation CRT configuration.

## SYSTEM CONFIGURATION

Existing CRTCs provide a single bus interface to the frame buffer which must be shared with the host MPU. However, the refresh of large frame buffers and the requirement to access the frame buffer for drawing operations can quickly saturate this shared bus bandwidth.

As shown in Figure 3, the ACRTC uses separate host MPU and frame buffer bus interfaces. This allows the ACRTC full access to the frame buffer for display refresh, DRAM refresh and drawing operations while minimizing the ACRTC's usage of the MPU system bus. Thus, overall system performance is maximized. A related benefit is that a large frame buffer (2Mbyte for each ACRTC) is usable even if the host MPU has a smaller address space or segment size restriction.

The ACRTC can utilize an external DMA controller. This increases system throughput when large amounts of command, parameter and data information must be transferred to the ACRTC. Also, advanced DMAC features, such as the 'chaining' modes, can be used to develop powerful graphics system architectures.

However, more cost-sensitive or less performance-sensitive applications do not require a DMAC. The interface to the ACRTC can be

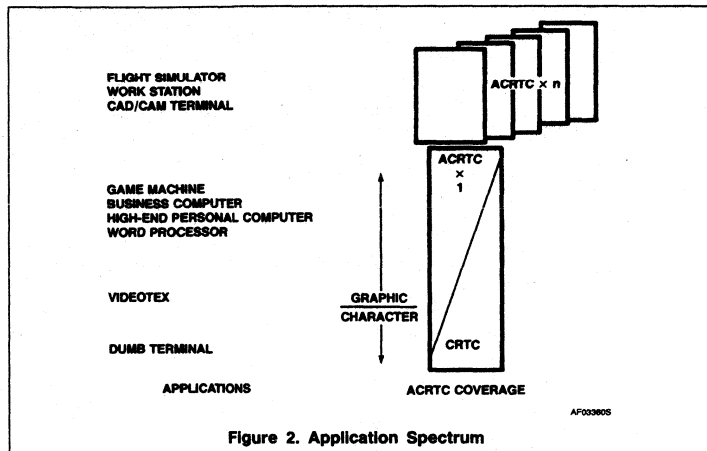

Figure 2. Application Spectrum

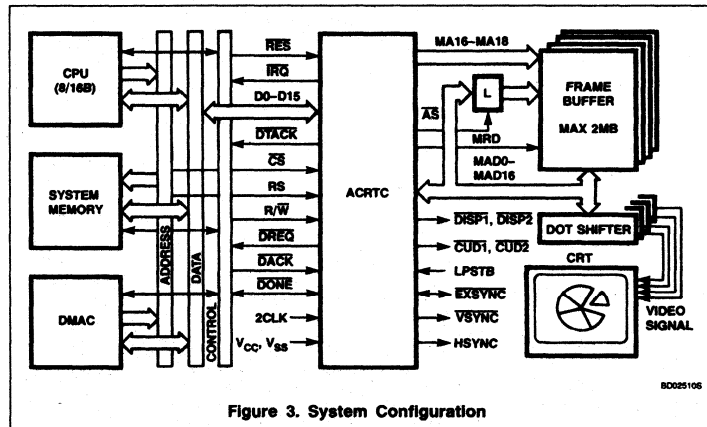

Figure 3. System Configuration

handled completely under MPU software control.

While both ACRTC bus interfaces (host MPU and frame buffer) exploit 16-bit data paths for maximum performance, the ACRTC also offers an 8-bit MPU mode for easy connection to popular 8-bit bus structures.

## VIDEO ATTRIBUTES

The ACRTC outputs 20 bits of video attributes on MAD0 - MAD15 and MA16/RA0 - MA19/RA3. These attributes are output at the last cycle prior to the rising edge of HSYNC and should be latched externally. Thus, video attributes can be set on a raster-by-raster basis (see Figure 4).

## Attribute Code (ATC0 - ATC7; MAD0 - MAD7)

These are user-defined attributes. The programmed contents of the attribute control bits (ATR) of the display control register (DCR) are output on these lines. Note that the data written into ATR can be externally used after the completion of current raster scanning.

## Attribute Code (ATC7 - ATC0)

### Application

ATC is one of the functions provided for user applications; the data employed depends on the system requirements. Application selections include:

1. Amount of horizontal dot shift for window smooth scroll
2. Horizontal width of crosshair cursor and the amount of horizontal dot shift (including block cursor)

# Advanced CRT Controller (ACRTC)

SCC63484

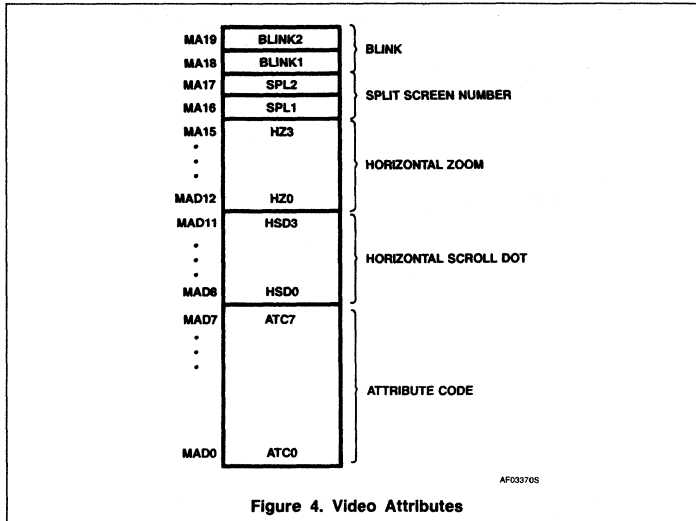

Figure 4. Video Attributes

3. Frame buffer specification in blocks (used for the base register)
4. Back screen color or character color code
5. Display screen selection during screen blink (used with SPL)
6. Interrupt vector address storage
7. Polarity selection of horizontal/vertical synchronization signal, etc.
8. Blinking signal like lamps used in the system
9. Code storage (maximum 8-bit) or selection signal, etc.

### Horizontal Scroll (HZ0 – HSD3:MAD8 – MAD11)

These are used in conjunction with external circuitry to implement smooth horizontal scroll. These lines contain the encoded start dot address which is used to control the external shift register load timing and data. HSD usually corresponds to the start dot address of the background screens. However, if the window smooth scroll (SWS) bit of the OMR (operation mode register) is set to 1, HSD outputs the start dot address of the window screen segment. Note that HSD outputs the valid value only within the specified raster area. Changing the register contents during the scanning does not cause any external effects, because the value loaded at the beginning of the area is reserved.

### Horizontal Zoom Factor (HZ0 – HZ3:MAD12 – MAD15)

These lines output the encoded (1 – 16) horizontal zoom factor as stored in the zoom factor register (ZFR). Horizontal zoom is ac-

complished by the ACRTC repeating a single display address and using the HZ outputs to control the external shift register clock. Horizontal zoom can only be applied to the base screen.

### Split Position (SPL1 – SPL2:MA16 – MA17)

These lines present the encoded information showing the enabled background screen currently being displayed by the ACRTC.

SPL2	SPL1	
0	0	Background screen not enabled or displayed
0	1	Base screen
1	0	Upper screen
1	1	Lower screen

Even if the split screen display is prohibited, SPL is output if the area is specified.

### Blink (BLINK1 – BLINK2:MA18 – MA19)

These lines are used to implement character and screen blink. The lines alternate from high to low periodically as defined in the blink control register (BCR). The blink frequency is specified in units of four field times. A field is defined as the period between successive VSYNC pulses.

### ADDRESS SPACE

The ACRTC allows the host to issue commands using logical X-Y coordinate addressing. The ACRTC converts these to physical linear word addresses with bit field offsets in the frame buffer. Figure 5 shows the relationship between a logical X-Y screen address and the frame buffer memory, organized as

sequential 16-bit words. The host may specify that a logical pixel consists of 1, 2, 4, 8 or 16 physical bits in the frame buffer. In the example, 4 bits per logical pixel is used allowing 16 colors or tones to be selected.

Up to four logical screens (upper, base, lower and window) are mapped into the ACRTC physical address space. The host specifies a logical physical start address, logical screen physical memory width (number of memory words per raster), logical pixel physical memory width (number of bits per pixel) and the logical origin physical address. Then, logical pixel X-Y addresses issued by the host or by the ACRTC drawing processor are converted to physical frame buffer addresses. The ACRTC also performs bit extraction and masking to map logical pixel operations (in the example, 4 bits) to 16-bit word frame buffer accesses.

The ACRTC has over two hundred bytes of accessible registers. These are organized as hardware-, directly-, and FIFO-accessible (see Figure 6 and Tables 1 and 2).

### Hardware-Accessible

The ACRTC is connected to the host MPU as a standard peripheral which occupies two word locations of the host address space. The RS (register select) pin selects one of these two locations. When RS is low, reads access the status register and writes access the address register. The status register summarizes the ACRTC state and is used by the MPU to monitor the overall operation of the ACRTC. The address register is used to program the ACRTC with the address of the specific directly-accessible register which the MPU wishes to access.

### Directly-Accessible

These registers are accessed by prior loading of the address register with the chosen register address. Then, when the MPU accesses the ACRTC with RS = 1, the chosen register is accessed. The FIFO entry enables access to FIFO-accessible registers using the ACRTC read and write FIFOs.

The command control register is used to control overall ACRTC operation such as aborting or pausing commands, defining DMA protocols, enabling/disabling interrupt sources, etc. The operation mode register defines basic parameters of ACRTC operation such as frame buffer access mode, display or drawing priority, cursor and display timing skew factors, raster scan mode, etc.

The display control register allows the independent enabling and disabling of each of the four ACRTC logical display screens (base, upper, lower, and window). Also, this register contains the 8 bits of user-definable video attributes.

## Advanced CRT Controller (ACRTC)

SCC63484

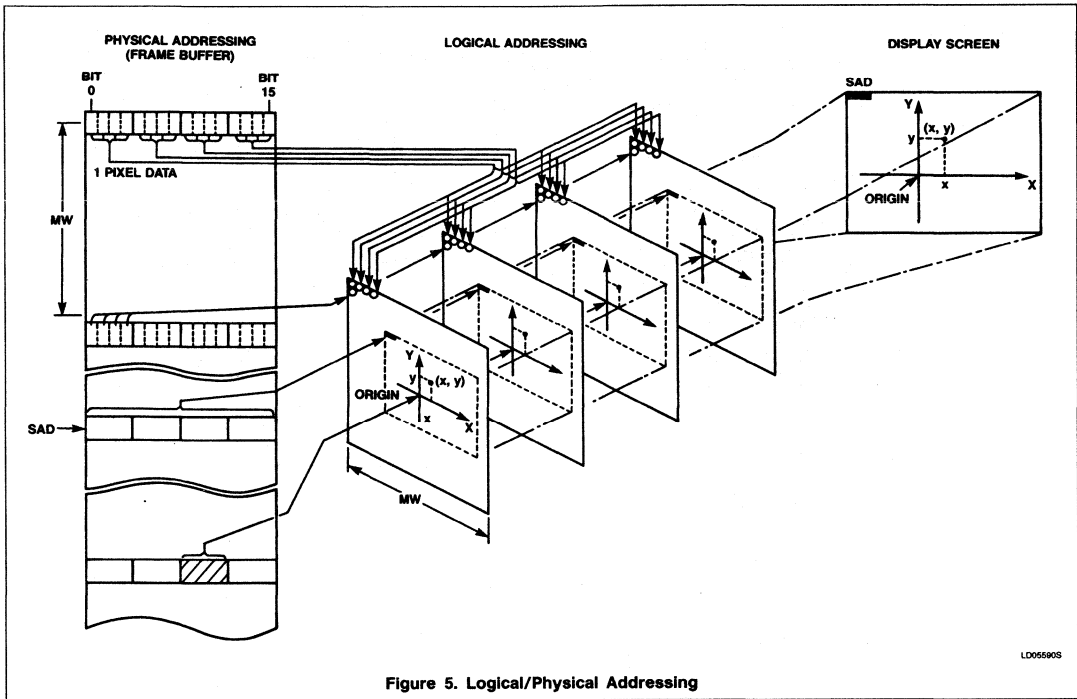

Figure 5. Logical/Physical Addressing

The timing control RAM contains registers which define ACRTC timing. This includes timing specification for CRT control signals (e.g. HSYNC, VSYNC), logical display screen size and display period, blink timing, etc. The display control RAM contains registers which define logical screen display parameters such as start addresses, raster addresses, and memory width. Also included are the cursor(s) definition, zoom factor, and light pen registers.

#### FIFO-Accessible

For high-performance drawing, key drawing processor registers are coupled to the host via the ACRTC's separate 16-byte read and write FIFOs. ACRTC commands are sent from the MPU via the write FIFO to the command register. As the ACRTC completes command execution, the next command is automatically fetched from the FIFO into the command register.

The pattern RAM is used to define drawing and painting 'patterns'. The pattern RAM is

accessed using the ACRTC's read pattern RAM (RPTN) and write pattern RAM (WPTN) register access commands.

The drawing parameter registers define detailed parameters of the drawing process, such as color control, area control (hitting/clipping) and pattern RAM pointers. The drawing parameter registers are accessed using the ACRTC's read parameter register (RPR) and write parameter register (WPR) register access commands.

# Advanced CRT Controller (ACRTC)

SCC63484

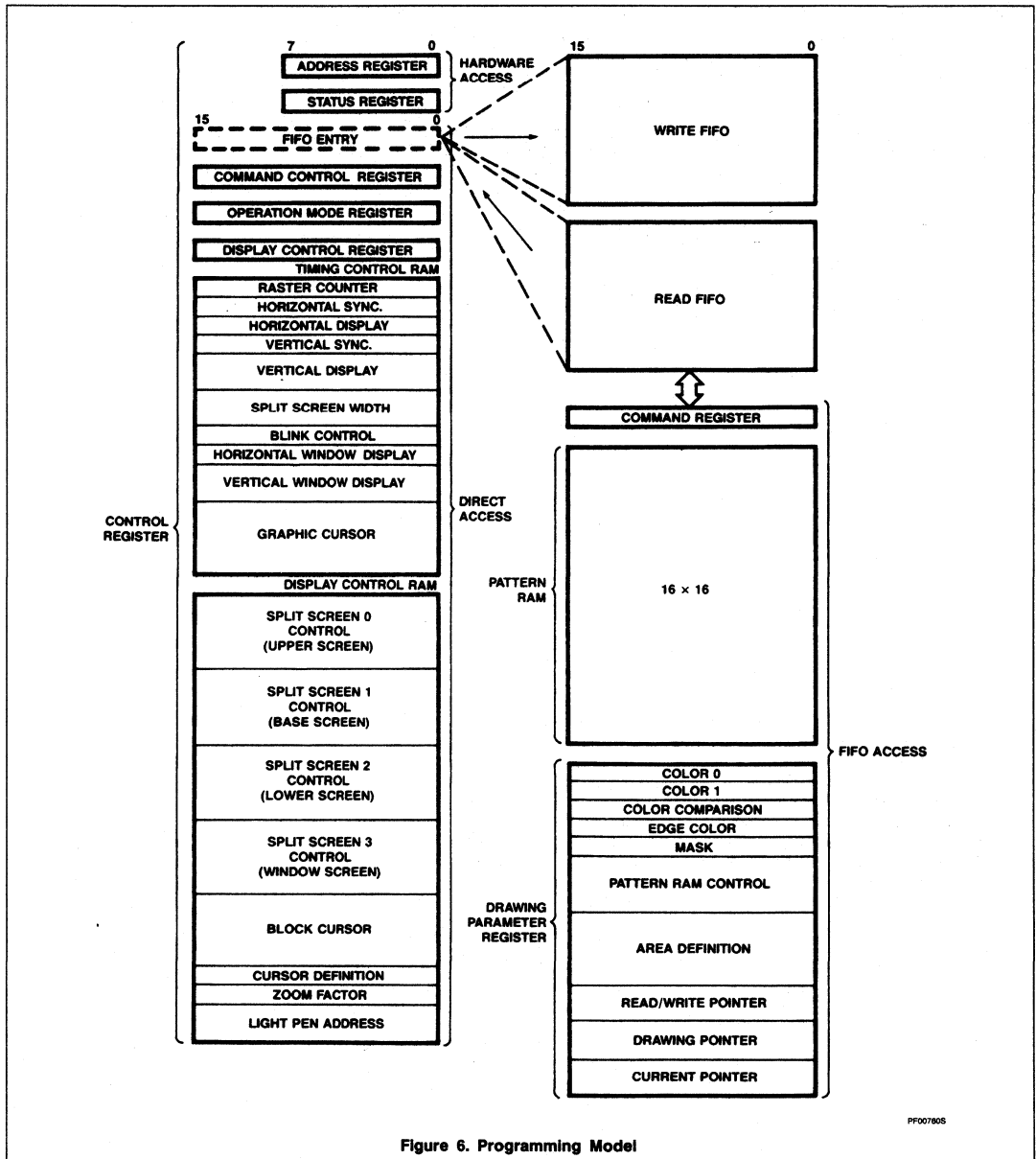

Figure 6. Programming Model

PF007805



# Advanced CRT Controller (ACRTC)

# SCC63484

**Table 1. Programming Model (Hardware Access, Direct Access Registers)**

CS	RS	RW	REG. NO.	REGISTER NAME	ABBRE.	DATA (H)								DATA (L)										
						15	14	13	12	11	10	9	8	7	6	5	4	3	2	1	0			
1	—	—	—	—	—	.....																		
0	0	0	AR	Address Register	AR	Address																		
0	0	1	SR	Status Register	SR	CER ARD CED LPD RFF RFR WFR WFE																		
0	1	1/0	r00	FIFO Entry	FE	FE																		
		1/0	r02	Command Control	CCR	ABT	PSE	DDM	CDM	DRC	GBM			CRE	ARE	CEE	LPE	RFE	RRE	WRE	WEE			
		1/0	r04	Operation Mode	OMR	M/S	STR	ACP	WSS	CSK	DSK		RAM	GAI		ACM	RSM							
		1/0	r06	Display Control	DCR	DSP	SE1	SE0		SE2		SE3		ATR										
		—	—	r08 ↓ r7E	(undefined)	—	.....																	
		1	1/0	r80	Raster Count	RCR	.....								RC									
		1/0	r82	Horizontal Sync.	HSR	.....								HC				HSW						
		1/0	r84	Horizontal Display	HDR	.....								HDS				HDW						
		1/0	r86	Vertical Sync.	VSR	.....								VC										
		1/0	r88	Vertical Display	VDR	.....								VDS				VSW						
		1/0	r8A	Split Screen Width	SSW	.....								SP1				SP0						
		1/0	r8C			.....								SP2				SP1						
		1/0	r8E			.....								SP2				SP1						
		1/0	r90	Blink Control	BCR	BON1				BOFF1				BON2				BOFF2						
		1/0	r92	Horizontal Window Display	HWR	.....								HWS				HWW						
		1/0	r94	Vertical Window Display	VWR	.....								VWS				VWS						
		1/0	r96			.....								VWW				VWW						
		1/0	r98			.....								CXE				CXS						
		1/0	r9A	Graphic Cursor	GCR	.....								CYS				CYS						
		1/0	r9C			.....								CYE				CYE						
		—	—			r9E	(undefined)	—	.....															
		—	—	—	rA0 ↓ rBE	(undefined)	—	.....																
		0	1	1/0	Upper Screen	Raster Addr. 0	RAR0	.....								LRA0				FRA0				
						Memory Width 0	MWR0	CHR	.....								MW0				MW0			
						Start Addr. 0	SAR0	.....								SDA0				SA0H/SRA0				
								SA0L																
				1/0	Base Screen	Raster Addr. 1	RAR1	.....								LRA1				FRA1				
						Memory Width 1	MWR1	CHR	.....								MW1				MW1			
						Start Addr. 1	SAR1	.....								SDA1				SA1H/SRA1				
								SA1L																
1/0	Upper Screen			Raster Addr. 2	RAR2	.....								LRA2				FRA2						
				Memory Width 2	MWR2	CHR	.....								MW2				MW2					
				Start Addr. 2	SAR2	.....								SDA2				SA2H/SRA2						
						SA2L																		
1/0	Window Screen	Raster Addr. 3	RAR3	.....								LRA3				FRA3								
		Memory Width 3	MWR3	CHR	.....								MW3				MW3							
		Start Addr. 3	SAR3	.....								SDA3				SA3H/SRA3								
				SA3L																				
1/0	rE0	Block Cursor 1	BCUR1	BCW1				BCSR1				BCA1				BCER1								
1/0	rE2			BCW2				BCSR2				BCA2				BCER2								
1/0	rE6	Block Cursor 2	BCUR2	BCW2				BCSR2				BCA2				BCER2								
1/0	rE8			BCW2				BCSR2				BCA2				BCER2								
1/0	rE8	Cursor Definition	CDR	CM	CON1				COFF1				CON2				COFF2							
1/0	rEA	Zoom Factor	ZFR	HZF				VZF				.....												
1	rEC	Light Pen Address	LPAR	.....								CHR	.....				LPAH							
1	rEE			LPAL																				
—	—	—	rF0 ↓ rFE	(undefined)	—	.....																		

NOTE: { 1 .... "High" level  
0 .... "Low" level

2

## Advanced CRT Controller (ACRTC)

SCC63484

## HARDWARE ACCESS, DIRECT ACCESS REGISTERS

ABT: Abort  
 ACM: Access Mode  
 ACP: Access Priority  
 Address: Register No. of the control register  
 ARD: Area Detect  
 ARE: Area Detect Interrupt Enable  
 ATR: Attribute Control  
 CDM: Command DMA Mode  
 CED: Command End  
 CEE: Command End Interrupt Enable  
 CER: Command Error  
 CRE: Command Error Interrupt Enable  
 CSK: Cursor Display Skew  
 DDM: Data DMA Mode  
 DRC: DMA Request Control  
 DSK: DISP Skew  
 DSP: DISP Signal Control  
 FE: FIFO Entry  
 GAI: Graphic Address Increment Mode  
 GBM: Graphic Bit Mode  
 HC: Horizontal Cycle  
 HDS: Horizontal Display Start  
 HDW: Horizontal Display Width  
 HSW: Horizontal Sync. Width  
 LPD: Light Pen Strobe Detect  
 LPE: Light Pen Strobe Interrupt Enable  
 M/S: Master/Slave  
 PSE: Pause  
 RAM: RAM Mode  
 RC: Raster Count  
 RFE: Read FIFO Full Interrupt Enable  
 RFF: Read FIFO Full  
 RFR: Read FIFO Ready  
 RRE: Read FIFO Ready Interrupt Enable  
 RSM: Raster Scan Mode  
 SE0: Split Enable 0  
 SE1: Split Enable 1  
 SE2: Split Enable 2  
 SE3: Split Enable 3  
 STR: Start  
 VC: Vertical Cycle  
 VDS: Vertical Display Start  
 VSW: Vertical Sync. Width  
 WEE: Write FIFO Empty Interrupt Enable  
 WFE: Write FIFO Empty  
 WFR: Write FIFO Ready  
 WRE: Write FIFO Ready Interrupt Enable  
 WSS: Window Smooth Scroll  
 SP0, SP1, SP2: Split Screen 0 Width, Split Screen 1 Width, Split Screen 2 Width  
 BON1, BON2: Blink ON 1, Blink ON 2  
 BOFF1, BOFF2: Blink OFF 1, Blink OFF 2  
 HWS: Horizontal Window Start  
 HWW: Horizontal Window Width  
 VWS: Vertical Window Start  
 VWW: Vertical Window Width  
 CXS, CYS: Cursor X Start, Cursor Y Start  
 CXE, CYE: Cursor X End, Cursor Y End  
 FRA: First Raster Address  
 LRA: Last Raster Address  
 CHR: Character  
 MW: Memory Width  
 SDA: Start Dot Address  
 SAH/SRA: Start Address "High"/Start Raster Address  
 SAL: Start Address "Low"  
 BCW1, BCW2: Block Cursor Width 1, Block Cursor Width 2  
 BCSR1, BCSR2: Block Cursor Start Raster 1, Block Cursor Start Raster 2  
 BCER1, BCER2: Block Cursor End Raster 1, Block Cursor End Raster 2  
 BCA1, BCA2: Block Cursor Address 1, Block Cursor Address 2  
 CM: Cursor Mode  
 CON1, CON2: Cursor ON 1, Cursor ON 2  
 COFF1, COFF2: Cursor OFF 1, Cursor OFF 2  
 HZF, VZF: Horizontal Zoom Factor, Vertical Zoom Factor  
 LPAH: Light Pen Address "High"  
 LPAL: Light Pen Address "Low"

# Advanced CRT Controller (ACRTC)

# SCC63484

**Table 2. Programming Model (Drawing Parameter Registers)**

REGISTER NO.	READ/ WRITE	NAME OF REGISTER	ABBR.	DATA (H)								DATA (L)								
				15	14	13	12	11	10	9	8	7	6	5	4	3	2	1	0	
Pr00	R/W	Color 0	CL0	CL0																
Pr01	R/W	Color 1	CL1	CL1																
Pr02	R/W	Color Comparison	CCMP	CCMP																
Pr03	R/W	Edge Color	EDG	EDG																
Pr04	R/W	Mask	MASK	MASK																
Pr05 ↓ Pr07	R/W	Pattern RAM Control	PRC	PPY				PZCY				PPX				PZCX				
				PSY				PSX				PEY				PZX				
				PEY				PZY				PEX				PZX				
Pr08 ↓ Pr0B	R/W	Area Definition **	ADR	XMIN																
				YMIN																
				XMAX																
				YMAX																
Pr0C Pr0D	R/W	Read/Write Pointer	RWP	DN									RWPH							
				RWPL																
Pr0E Pr0F	—	.....	—	—																
Pr10 Pr11	R	Drawing Pointer	DP	DN									DPAH							
				DPAL								DPD								
Pr12 Pr13	R	Current Pointer **	CP	X																
				Y																
Pr14 Pr15	—	.....	—	—																

**NOTES:**

- ☐ .... Always set to '0'
- \*\* .... Set binary complements for negative values of X and Y axis.

**DRAWING PARAMETER REGISTER**

- R: Register which can be read by Read Parameter Register command (RPR)
- W: Register which can be written into by Write Parameter Register command (WPR)
- : Access is not allowed
- CL0: Defines the color data used for the drawing when logical drawing data = 0
- CL1: Defines the color data used for the drawing when logical drawing data = 1
- CCMP: Defines the comparative color of the drawing operation
- EDG: Defines the edge color
- MASK: Defines the bit pattern used to mask bits upon which data transfer should not be performed
- PSX, PSY: Pattern Start Point
- PEX, PEY: Pattern End Point
- PPX, PPY: Pattern Scan Start Point
- PZX, PZY: Pattern Zoom
- PZCX, PZCY: Pattern Zoom Count
- XMIN, YMIN: Start point of Area definition
- XMAX, YMAX: End point of Area definition
- DN: Screen Number
- RWPH: High-order 8 bits of Read Write Pointer Address
- RWPL: Low-order 12 bits of Read Write Pointer Address
- DPAH: High-order 8 bits of Drawing Pointer Address
- DPAL: Low-order 12 bits of Drawing Pointer Address
- DPD: Drawing Pointer Dot Address
- X, Y: Position indicated by Current Pointer on X-Y coordinate

2

# Advanced CRT Controller (ACRTC)

SCC63484

## COMMANDS

The ACRTC has 38 commands classified into three groups — register access, data transfer, and graphic drawing (see Table 3). Five register access commands allow access to drawing processor, drawing parameter registers, and the pattern RAM. Ten data transfer commands are used to move data between the host system memory and the frame buffer, or within the frame buffer. Twenty-three graphic drawing commands cause the ACRTC to perform drawing operations. Parameters for these commands are specified using logical X-Y addressing.

All of the above commands, parameters and data are transferred via the ACRTC read and write FIFOs.

Assuming the ACRTC has been properly initialized, the MPU must perform two steps to cause graphic drawing. First, the MPU must specify certain drawing parameters which define a number of details associated with the drawing process. For example, to draw a figure or paint an area, the MPU must specify the drawing or painting 'pattern' by initializing the ACRTC pattern RAM and related pointers. Also, if clipping and hitting control are desired, the MPU specifies the 'area' to be

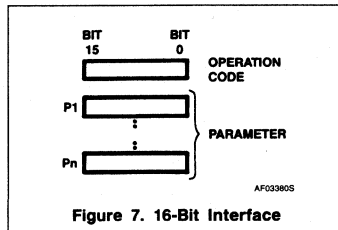

Figure 7. 16-Bit Interface

monitored during drawing by initializing area definition registers. Other drawing parameters include color, edge definition, etc.

After the drawing parameters have been specified, the MPU issues a graphic drawing command and any required command parameters, such as the CRCL (circle) command with a radius parameter. The ACRTC then performs the specified drawing operation by reading, modifying and rewriting the contents of the frame buffer.

### Command Format

ACRTC commands consist of a 16-bit opcode, optionally followed by one or more 16-bit parameters. When 8-bit MPU mode is used, commands, parameters, and data are

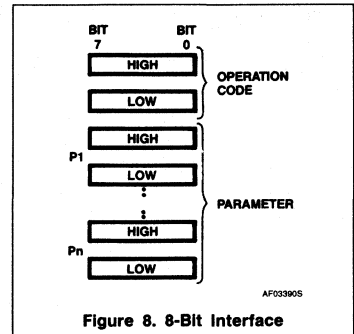

Figure 8. 8-Bit Interface

sent to and from the ACRTC in the order of high-byte, low-byte.

**16-Bit Interface** — In the case of 16-bit interface, first move the 16-bit operation code and then move necessary 16-bit parameters one by one (see Figure 7).

**8-Bit Interface** — In the case of 8-bit interface, first move the operation code's high byte followed by low byte, and then move the parameters in the same order (see Figure 8).

## REGISTER ACCESS COMMAND

MNEMONIC	OPERATION CODE						PARAMETER		NO. WORDS	~ (CYCLES)
ORG	0 0 0 0	0 1	0 0	0 0 0 0	0 0 0 0		DPH DPL	3	8	
WPR	0 0 0 0	1 0	0 0	0 0 0		RN	D	2	6	
RPR	0 0 0 0	1 1	0 0	0 0 0		RN		1	6	
WPTN	0 0 0 1	1 0	0 0	0 0 0 0		PRA	n D <sub>1</sub> ,.....,D <sub>n</sub>	n + 2	4n + 8	
RPTN	0 0 0 1	1 1	0 0	0 0 0 0		PRA	n	2	4n + 10	

- RN : Register number of the drawing parameter register (\$0 - \$13)
- PRA: Pattern RAM address at which Read/Write operation starts (\$0 - \$F)
- DPH: Drawing pointer register High word
- DPL: Drawing pointer register Low word

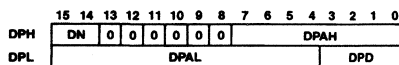

- DPAH: Higher 8 bits of Drawing Pointer address
- DPAL: Lower 12 bits of Drawing Pointer address
- DPD: Dot position in the memory address

- D, D<sub>1</sub>,.....,D<sub>n</sub>: Write data
- n: Number of Read/Write data

DN	SCREEN NO.
00	Upper Screen
01	Base Screen
10	Lower Screen
11	Window Screen

# Advanced CRT Controller (ACRTC)

SCC63484

## DATA TRANSFER COMMAND

MM: Modify Mode

MM	FUNCTION	
00	Replace	Replace drawing point data with modifier information
01	OR	OR drawing point data with modifier data and rewrite the result data to the frame buffer
10	AND	AND drawing point data with modifier data and rewrite the result data to the frame buffer
11	Ex-OR	Ex-OR drawing point data with modifier data and rewrite the result data to the frame buffer

**S : SOURCE SCAN DIRECTION**

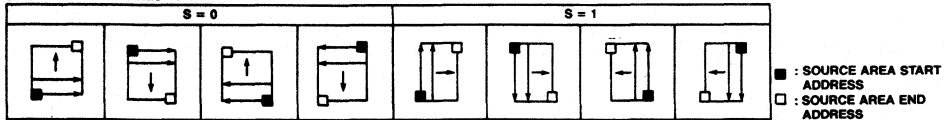

**DSD : DESTINATION SCAN DIRECTION**

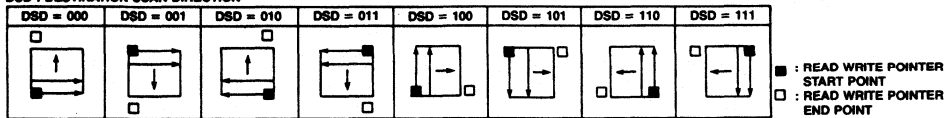

DF05905

AX: Number of word in X-axis direction-1

AY: Number of word in Y-axis direction-1

D: Write data

SAH: Source Start Address High word

SAL: Source Start Address Low word

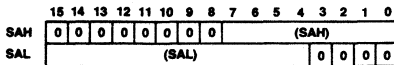

(SAH): Memory address Higher 8 bits

(SAL): Memory address Lower 12 bits

x: Number of word in X-axis direction

y: Number of word in Y-axis direction

T: Rounding up

# Advanced CRT Controller (ACRTC)

# SCC63484

## GRAPHIC DRAWING COMMAND

AREA : Area Mode  
 COL : Color Mode  
 OPM : Operation Mode

C: Circling Direction

C	DIRECTION
0	Counterclockwise
1	Clockwise

E: Definition of Edge color

E	DEFINITION
0	Edge color is defined by the data in the edge color register.
1	Edge color is defined by the data excluding the above.

SL : SLANT, SD : SCAN DIRECTION

SD \ SL	000	001	010	011	100	101	110	111
0								
1								

● : CURRENT POINTER START POINT  
 ○ : CURRENT POINTER END POINT

S : SOURCE SCAN DIRECTION

S = 0				S = 1			

● : SOURCE AREA START DOT POSITION  
 ○ : SOURCE AREA END DOT POSITION

DSD : DESTINATION SCAN DIRECTION

DSD = 000	DSD = 001	DSD = 010	DSD = 011	DSD = 100	DSD = 101	DSD = 110	DSD = 111

● : CURRENT POINTER START POINT  
 ○ : CURRENT POINTER END POINT

DF056905

- X, X1, . . . , Xn : Absolute X-address from the original point
- Y, Y1, . . . , Yn : Absolute Y-address from the original point
- dX : Relative X-address from the current pointer
- dY : Relative Y-address from the current pointer
- n : Number of nodes
- dX1, . . . , dXn : Relative X-address from each node
- dY1, . . . , dYn : Relative Y-address from each node
- r : Dot number on radius
- a, b :  $(DX)^2 + (DY)^2 = a^2 + b^2$
- DX : X-direction dot number
- DY : Y-direction dot number
- Xc : Absolute X-address of the center point of arc/ellipse
- Yc : Absolute Y-address of the center point of arc/ellipse
- dXc : Relative X-address from the current pointer to the center point of arc/ellipse
- dYc : Relative Y-address from the current pointer to the center point of arc/ellipse

- Xe : Absolute X-address of the end point of arc/ellipse
- Ye : Absolute Y-address of the end point of arc/ellipse
- dXe : Relative X-address from the current pointer to the end point of arc/ellipse
- dYe : Relative Y-address from the current pointer to the end point of arc/ellipse
- Xs : Absolute X-address of the start dot position in source area
- Ys : Absolute Y-address of the start dot position in source area
- dXs : Relative X-address from the current pointer to the start dot position in source area
- dYs : Relative Y-address from the current pointer to the start dot position in source area
- P :  $4(OPM = 000 - 011)/6(OPM = 100 - 111)$
- L, L0 : Dot number on straight line
- d : Total dot number
- A : Scan main direction dot number
- B : Scan sub direction dot number

# Advanced CRT Controller (ACRTC)

# SCC63484

2

**Table 3. ACRTC Command Table**

TYPE	MNEMONIC	COMMAND NAME	OPERATION CODE	PARAMETER	NO. WORDS	(CYCLES) <sup>3</sup>
Register Access Command	ORG	Origin	0 0 0 0 1 0 0 0 0 0 0 0 0 0 0 0	DPH DPL	3	8
	WPR	Write Parameter Register	0 0 0 0 1 0 0 0 0 0 0 0 0 0 0 0	RN D	2	6
	RPR	Read Parameter Register	0 0 0 0 1 1 0 0 0 0 0 0 0 0 0 0	RN	1	6
	WPTN	Write Pattern RAM	0 0 0 1 1 0 0 0 0 0 0 0 0 0 0 0	PRA n D <sub>1</sub> ...D <sub>n</sub>	n + 2	4n + 8
Data Transfer Command	RPTN	Read Pattern RAM	0 0 0 1 1 1 0 0 0 0 0 0 0 0 0 0	PRA n	2	4n + 10
	DRD	DMA Read	0 0 1 0 0 1 0 0 0 0 0 0 0 0 0 0	AX AY	3	(4x + 8)y + 12[x · y/81] + (62 ~ 66)
	DWT	DMA Write	0 0 1 0 1 0 0 0 0 0 0 0 0 0 0 0	AX AY	3	(4x + 8)y + 16[x · y/81] + 34
	DMOD	DMA Modify	0 0 1 0 1 1 0 0 0 0 0 0 0 0 0 0	AX AY	3	(4x + 8)y + 16[x · y/81] + 34
	RD	Read	0 1 0 0 0 1 0 0 0 0 0 0 0 0 0 0	D	1	
	WT	Write	0 1 0 0 1 0 0 0 0 0 0 0 0 0 0 0	D	2	8
	MOD	Modify	0 1 0 0 1 1 0 0 0 0 0 0 0 0 0 0	D MM	2	8
	CLR	Clear	0 1 0 1 1 0 0 0 0 0 0 0 0 0 0 0	D AX AY	4	(2x + 8)y + 12
	SCLR	Selective Clear	0 1 0 1 1 1 0 0 0 0 0 0 0 0 0 0	D AX AY MM	4	(4x + 6)y + 12
	COPY	Copy	0 1 1 0 1 S DSD 0 0 0 0 0 0 0 0 0 0	SAH SAL AX AY	5	(6x + 10)y + 12
Graphic Command	SCPY	Selective Copy	0 1 1 1 1 S DSD 0 0 0 0 0 0 0 0 0 0	SAH SAL AX AY	5	(6x + 10)y + 12
	AMOVE	Absolute Move	1 0 0 0 0 0 0 0 0 0 0 0 0 0 0 0	X Y	3	56
	RMOVE	Relative Move	1 0 0 0 0 1 0 0 0 0 0 0 0 0 0 0	dX dY	3	56
	ALINE	Absolute Line	1 0 0 0 1 0 0 0 0 0 0 0 0 0 0 0	AREA COL OPM X Y	3	P · L + 18
	RLINE	Relative Line	1 0 0 0 1 1 0 0 0 0 0 0 0 0 0 0	AREA COL OPM dX dY	3	P · L + 18
	ARCT	Absolute Rectangle	1 0 0 1 0 0 0 0 0 0 0 0 0 0 0 0	AREA COL OPM X Y	3	2P(A + B) + 54
	RRCT	Relative Rectangle	1 0 0 1 0 1 0 0 0 0 0 0 0 0 0 0	AREA COL OPM dX dY	3	2P(A + B) + 54
	APLL	Absolute Polyline	1 0 0 1 1 0 0 0 0 0 0 0 0 0 0 0	AREA COL OPM n X1, Y1...Xn, Yn	2n + 2	Σ[P · L + 16] + 8
	RPLL	Relative Polyline	1 0 0 1 1 1 0 0 0 0 0 0 0 0 0 0	AREA COL OPM n dX1, dY1...dXn, dYn	2n + 2	Σ[P · L + 16] + 8
	APLG	Absolute Polygon	1 0 1 0 0 0 0 0 0 0 0 0 0 0 0 0	AREA COL OPM n X1, Y1...Xn, Yn	2n + 2	Σ[P · L + 16] + P · Lo + 20
	RPLC	Relative Polygon	1 0 1 0 0 1 0 0 0 0 0 0 0 0 0 0	AREA COL OPM n dX1, dY1...dXn, dYn	2n + 2	Σ[P · L + 16] + P · Lo + 20
	CRCL	Circle	1 0 1 0 1 0 0 0 0 0 0 0 0 0 0 0	AREA COL OPM r	2	8d + 66
	ELPS	Ellipse	1 0 1 0 1 1 0 0 0 0 0 0 0 0 0 0	AREA COL OPM a b dX	4	10d + 90
	AARC	Absolute Arc	1 0 1 1 0 0 0 0 0 0 0 0 0 0 0 0	AREA COL OPM Xc Yc Xe Ye	5	8d + 18
	RARC	Relative Arc	1 0 1 1 0 1 0 0 0 0 0 0 0 0 0 0	AREA COL OPM dXc dYc dXe dYe	5	8d + 18
	AEARC	Absolute Ellipse Arc	1 0 1 1 1 0 0 0 0 0 0 0 0 0 0 0	AREA COL OPM a b Xc Yc Xe Ye	7	10d + 96
	REARC	Relative Ellipse Arc	1 0 1 1 1 1 0 0 0 0 0 0 0 0 0 0	AREA COL OPM a b dXc dYc dXe dYe	7	10d + 96
	AFRCT	Absolute Filled Rectangle	1 1 0 0 0 0 0 0 0 0 0 0 0 0 0 0	AREA COL OPM X Y	3	(P · A + B)B + 18
	RFRC	Relative Filled Rectangle	1 1 0 0 0 1 0 0 0 0 0 0 0 0 0 0	AREA COL OPM dX dY	3	(P · A + B)B + 18
	PAINT	Paint	1 1 0 0 1 0 0 0 0 0 0 0 0 0 0 0	AREA 0 0 0 0 0 0	1	(18A + 102)B - 56 <sup>1</sup>
	DOT	Dot	1 1 0 0 1 1 0 0 0 0 0 0 0 0 0 0	AREA COL OPM	1	8
	PTN	Pattern	1 1 0 1 1 SL SD AREA COL OPM	Sz <sup>2</sup>	2	(P · A + 10)B + 20
	AGCPY	Absolute Graphic Copy	1 1 1 0 1 S DSD AREA 0 0 0 0 0 0	Xs Ys DX DY	5	((P + 2)A + 10)B + 70
	RGCPY	Relative Graphic Copy	1 1 1 1 1 S DSD AREA 0 0 0 0 0 0	dXs dYs DX DY	5	((P + 2)A + 10)B + 70

**NOTES:**

1. In case of rectangular filling

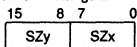

2. SZ: SZy, SZx: Pattern Size

- n: number of repetition X/Y: drawing words of X-direction/Y-direction
- L/Lo/d: sum of drawing dots A/B: drawing dots of main/sub direction
- E: [E = 0 (Stop at Edge color), E = 1 (Stop at excepting Edge color)] C: [C = 1 (clockwise), C = 0 (reverse)]
- [f]: rounding up
- P = 4: OPM-000 - 011
- 6: OPM-100 - 111

3. Cycles: 2 clock cycle time

## Advanced CRT Controller (ACRTC)

SCC63484

**PROGRAM TRANSFER**

Program transfer occurs when the MPU specifies the FIFO entry address and then writes commands/parameters to the write FIFO under program control (RS = high; R/W, CS = low). The MPU writes are normally synchronized with the ACRTC FIFO status by software polling or interrupts.

**Software Polling (WFR, WFE Interrupts Disabled)**

1. MPU program checks the SR (status register) for write FIFO ready (WFR) flag = 1, and then writes 1-word op-code/parameters.
2. MPU program checks the SR (status register) for write FIFO empty (WFE) flag = 1, and then writes 1- to 8-word op-code/parameters.

**Interrupt-Driven (WFR, WFE Interrupts Enabled)**

1. MPU WFR interrupt service routine writes 1-word op-code/parameters.
2. MPU WFE interrupt service routine writes 1- to 8-word op-code/parameters.

In the specific case of register access commands and an initially empty write FIFO, MPU writes need not be synchronized to the write FIFO status. The ACRTC can fetch and execute these commands faster than the MPU can issue them.

**COMMAND DMA TRANSFER**

Commands and parameters can be transferred from MPU system memory using an external DMAC. The MPU initiates and terminates command DMA transfer mode under software control (CDM bit of CCR). Command DMA can also be terminated by assertion of the ACRTC  $\overline{DONE}$  signal.  $\overline{DONE}$  is treated as an input in command DMA transfer mode.

Using command DMA transfer, the ACRTC will issue cycle stealing DMA requests to the DMAC when the write FIFO is empty. The DMA data is automatically sent from system memory to the ACRTC write FIFO regardless of the contents of the address register.

**NOTES:**

1. Ensure that the write FIFO is empty and all the commands are terminated before starting the command DMA transfer.
2. The data DMA command cannot be executed in the command DMA transfer mode.

**Register Access Commands**

Registers associated with the drawing processor (pattern RAM and drawing parameter registers) are accessed through the read and write FIFOs using the register access commands.

**Data Transfer Commands**

Data transfer commands are used to move blocks of data between the MPU system

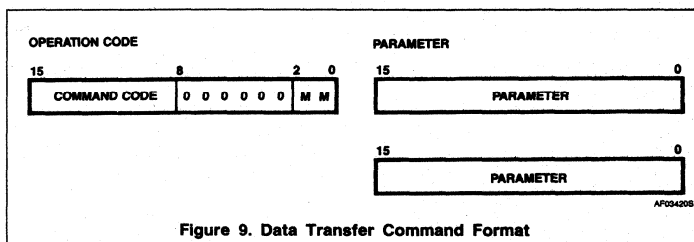

Figure 9. Data Transfer Command Format

**Table 4. Register Access Commands**

COMMAND	FUNCTION
ORG	Initialize the relation between the origin point in the X-Y coordinates and the physical address
WPR	Write into the parameter register
RPR	Read the parameter register
WPTN	Write into the pattern RAM
RPTN	Read the pattern RAM

**Table 5. Data Transfer Commands**

COMMAND	FUNCTION
DRD	Transfer data, by DMA transfer, from the frame buffer to the MPU system memory
DWT	Transfer data, by DMA transfer, from the MPU system memory to the frame buffer
DMOD	Transfer data, by DMA transfer, from the MPU system to the frame buffer subject to logical modification (bit-maskable)
RD	Read one word of data from the frame buffer specified by the read/write pointer (RWP), and load the word into Read FIFO
WT	Write one word of data to the frame buffer specified by the read/write pointer (RWP)
MOD	Perform logical operation on one word in the frame buffer specified by the read/write pointer (RWP) (bit-maskable)
CLR	Clear a rectangular area of the frame buffer with a data in the command parameter
SCLR	Initialize a rectangular area of the frame buffer with 1-word data subject to logical operation (bit-maskable)
CPY	Copy frame buffer data from one area (source area) to another area (destination area) specified by the read/write pointer (RWP).
SCPY	Copy frame buffer data from one area (source area) to another area (destination area) subject to logical modification by word. The source and destination areas must reside on the same screen (bit-maskable)

memory and the ACRTC frame buffer or within the frame buffer itself. Before issuing these commands, a physical 20-bit frame buffer address must be specified in the RWP (read/write pointer) drawing parameter register.

Tables 4 and 5 list register access commands and data transfer commands. Figure 9 shows the data transfer command format.

**MODIFY MODE**

The DMOD, MOD, SCLR and SCPY commands allow four types of bit-level logical operations to be applied to frame buffer data. The modify mode is encoded in the lower two bits (MM) of these op-codes. The bit positions within each frame buffer word to be modified are selectable using the mask register (MASK). Bits set to 1 are modifiable, ones to 0 are masked and not modifiable.



## Advanced CRT Controller (ACRTC)

SCC63484

MM	Modify Mode
0 0	REPLACE frame buffer data with command parameter data
0 1	OR frame buffer data with command parameter data and rewrite to the frame buffer
1 0	AND frame buffer data with command parameter data and rewrite to the frame buffer
1 1	Ex-OR frame buffer data with command parameter data and rewrite to the frame buffer

### GRAPHIC DRAWING COMMANDS

The ACRTC has 23 separate graphic drawing commands (see Table 6). Graphic drawing is performed by modifying the contents of the frame buffer based on microcoded drawing algorithms in the ACRTC drawing processor.

Most coordinate parameters for graphic drawing commands are specified using logical pixel X-Y addressing.

The complex task of translating a logical pixel address to a linear frame buffer word address, and further selecting the appropriate sub-field of the word is performed at high speed by ACRTC hardware. For example, a given logical pixel in 4 bits per logical pixel mode might reside in bits 8 - 11 of a frame buffer word.

Many instructions allow specification of X-Y coordinates with either absolute or relative X-Y coordinates (e.g., ALINE and RLINE). In both cases, two's complement numbers are used to represent positive and negative result values.

#### Absolute Coordinate Specification

The screen address (X, Y) is specified in units of logical pixels relative to an origin point defined with the ORG command (see Figure 10).

#### Relative Coordinate Specification

The screen address (dX, dY) is specified in units of logical pixels relative to the current drawing pointer (CP) position. A graphic drawing command consists of a 16-bit op-code and optionally 0 to 64k 16-bit parameters (see Figure 11). The 16-bit op-code consists of an 8-bit command code, an area mode specifier (3 bits), a color mode specifier (2 bits) and an operation mode specifier (3 bits).

Table 6. Graphic Drawing Commands

COMMAND	FUNCTION
AMOVE	Move the current pointer (CP) to an absolute logical pixel X-Y address
RMOVE	Move the CP to a relative logical pixel X-Y address
ALINE	Draw a straight line from the CP to a command-specified endpoint of the absolute coordinates
RLINE	Draw a straight line from the CP to a command-specified endpoint of the relative coordinates
ARCT	Draw a rectangle defined by the CP and a command-specified diagonal point of the absolute coordinates
RRCT	Draw a rectangle defined by the CP and a command-specified diagonal point of the relative coordinates
APLL	Draw a polyline (multiple contiguous segments) from the CP through command-specified points of the absolute coordinates
RPLL	Draw a polyline (multiple contiguous segments) from the CP through command-specified points of the relative coordinates
APLG	Draw a polygon which connects the start pointer (CP) and command-specified points of the absolute coordinates
RPLG	Draw a polygon which connects the CP and command-specified points of the relative coordinates
CRCL	Draw a circle of the radius, R, placing the CP at the center
ELPS	Draw an ellipse whose shape is specified by command parameters, placing the CP at the center
AARC	Draw an arc by using the CP as a start point with an end point and a center point of the absolute coordinates
RARC	Draw an arc by using the CP as a start point with an end point and a center point of the relative coordinates.
AEARC	Draw an ellipse arc by using the CP as a start point with an end point and a center point of the absolute coordinates
REARC	Draw an ellipse arc by using the CP as a start point with an end point and a center point of the relative coordinates
AFRCT	Paint a rectangular area specified by the CP and command parameters (absolute coordinates) according to a figure pattern stored in the pattern RAM (tiling).
RFRCT	Paint a rectangular area specified by the CP and command parameters (relative coordinates) according to a figure pattern stored in the pattern RAM (tiling).
PAINT	Paint a closed area surrounded by edge color using a figure pattern stored in the pattern RAM (tiling).
DOT	Mark a dot on the coordinates where the CP indicates
PTN	Draw a graphic pattern defined in the pattern RAM onto a rectangular area specified by the CP and by the pattern size (rotation angle: 45°)
AGCPY	Copy a rectangular area specified by the absolute coordinates to the address specified by the CP, (rotation angle: 90°/mirror turnover)
RGCPY	Copy a rectangular area specified by the relative coordinates to the address specified by the CP (rotation angle: 90°/mirror turnover)

2

# Advanced CRT Controller (ACRTC)

SCC63484

The area mode allows versatile clipping and hitting detection. A drawing area can be defined, and should drawing operations attempt to enter or leave that area, a number of programmable actions can be taken by the ACRTC.

### Absolute Coordinate Specification

Specifies the addresses (x, y) based on the origin point set by the ORG command.

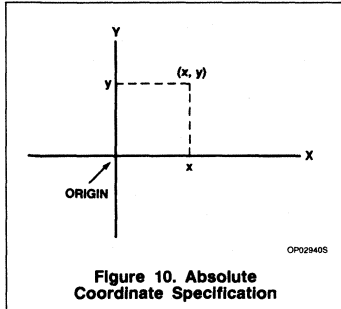

Figure 10. Absolute Coordinate Specification

### Relative Coordinate Specification

Specifies the relative addresses ( $\Delta x$ ,  $\Delta y$ ) related to the current drawing point.

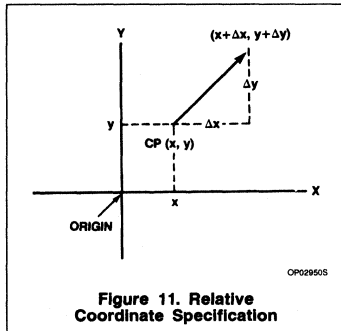

Figure 11. Relative Coordinate Specification

The color mode determines whether the pattern RAM is used indirectly to select color registers or is directly used as the color information.

The operation mode defines one of eight logical operations to be performed between the frame buffer read data and the color data in the pattern RAM to determine the drawing data to be rewritten into the frame buffer. Figure 12 shows the graphic drawing command format.

### OPERATION MODE

The operation mode (OPM bits) of the graphic drawing command specify the logical drawing condition.

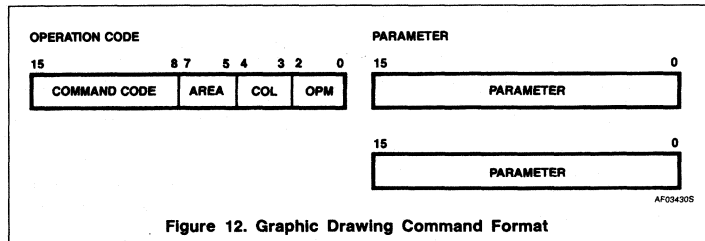

Figure 12. Graphic Drawing Command Format

Figure 13 shows examples of a drawing pattern applied with various OPM modes.

- | OPM   | Operation Mode  |
|-------|---|
| 0 0 0 | REPLACE:<br>* Replaces the frame buffer data with the color data  |
| 0 0 1 | OR:<br>* ORs the frame buffer data with the color data. The result is rewritten to the frame buffer   |
| 0 1 0 | AND:<br>* ANDs the frame buffer data with the color data. The result is rewritten to the frame buffer   |
| 0 1 1 | Ex-OR:<br>* Ex-ORs the frame buffer data with the color data. The result is rewritten to the frame buffer.  |
| 1 0 0 | CONDITIONAL REPLACE (read data = CCMP):<br>* When the frame buffer data at the drawing position is equal to the comparison color (CCMP), the frame buffer data is replaced with the color data          |
| 1 0 1 | CONDITIONAL REPLACE (read data $\neq$ CCMP):<br>* When the frame buffer data at the drawing position is not equal to the comparison color (CCMP), the frame buffer data is replaced with the color data |
| 1 1 0 | CONDITIONAL REPLACE (read data < CL):<br>* When the frame buffer data at the drawing position is less than the color register data (CL), the frame buffer data is replaced with the color data          |
| 1 1 1 | CONDITIONAL REPLACE (read data > CL):<br>* When the frame buffer data at the drawing position is greater than the color register data (CL), the frame buffer data is replaced with the color data.      |
- \* Normally, the color register (CL0 or CL1) selected by the pattern pointer (PPX, PPY) is used for the color data, but the source area data is used in the graphic copy commands (AGCPY and RGCPY).
- \*\* Normally, the color register (CL0 or CL1) selected by the pattern pointer (PPX, PPY) is used for the color register data (CL), but the source area data is used in the graphic copy command (AGCPY and RGCPY).

### COLOR MODE

The color mode (COL bits) specify the source of the drawing color data as directly or indirectly (using the color registers) determined by the contents of the pattern RAM.

- | COL | Color Mode   |
|-----|--|
| 0 0 | When pattern RAM data = 0, color register 0 is used<br>When pattern RAM data = 1, color register 1 is used |
| 0 1 | When pattern RAM data = 0, drawing is suppressed<br>When pattern RAM data = 1, color register 1 is used    |
| 1 0 | When pattern RAM data = 0, color register 0 is used<br>When pattern RAM data = 1, drawing is suppressed    |
| 1 1 | Pattern RAM contents are directly used as color data   |

The color mode chooses the source for color information based on the contents (0 or 1) of a particular bit in the 16-bit by 16-bit (32-byte) pattern RAM. A sub-pattern is specified by programming the pattern RAM control register (PRC) with the start (PSX, PSY) and end (PEX, PEY) points which define the diagonal of the sub-pattern. Furthermore, a specific starting point for pattern RAM scanning is specified by PPX and PPY (see Figure 14).

Normally, the color registers (CL) should be loaded with on color data based on the number of bits per pixel. For example, if four bits/pixel are used, the 4-bit color pattern (e.g. 0001) should be replicated four times in the color register, as shown below.

Color Register = 

0001	0001	0001	0001
------	------	------	------

In this way, color changes due to changing dot address are avoided.

### AREA MODE

Prior to drawing, a drawing 'area' may be defined (area definition register). Then, during graphics drawing operation, the ACRTC will check if the drawing point is attempting to enter or exit the defined drawing area. Based on eight area modes, the ACRTC will take appropriate action for clipping or hitting.

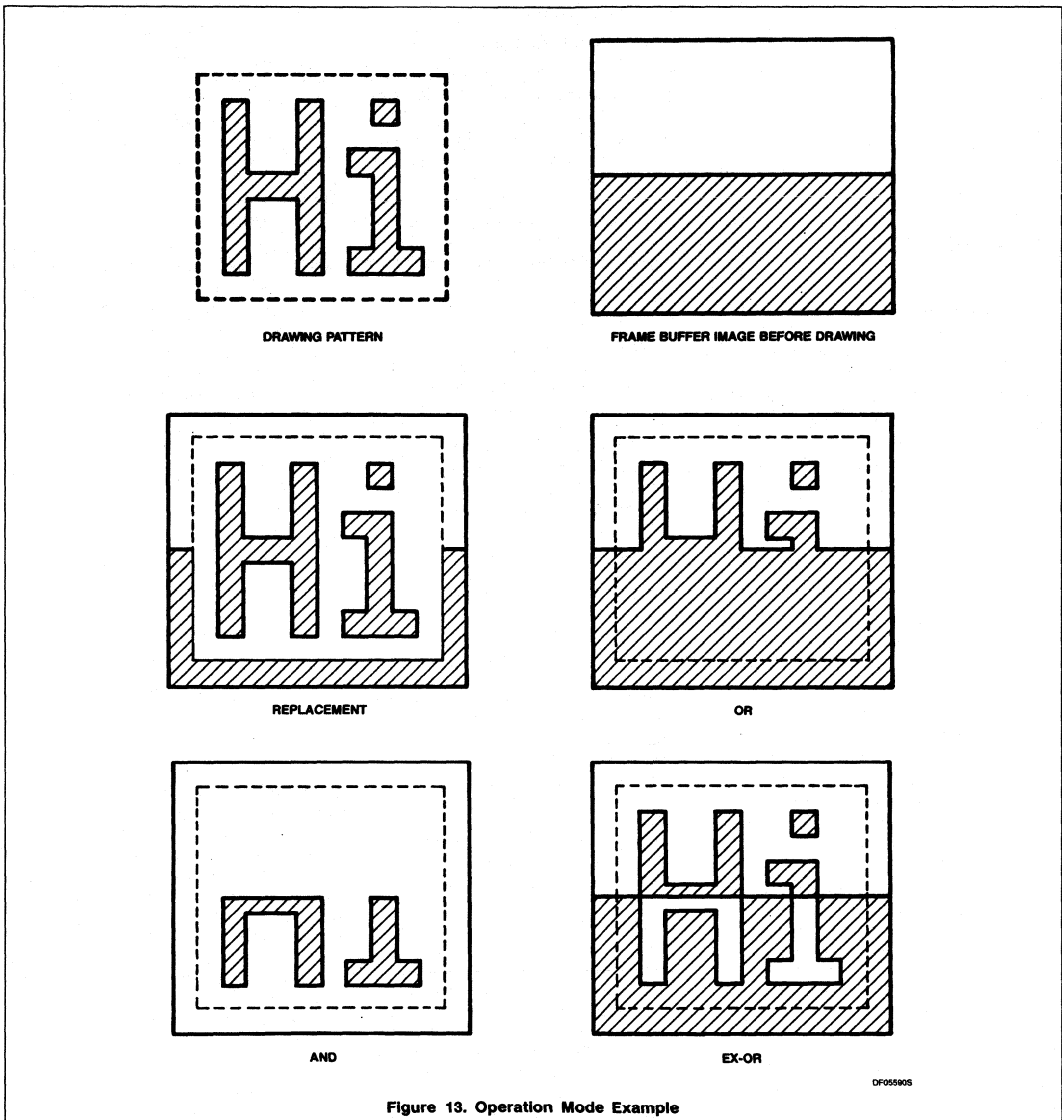

## Advanced CRT Controller (ACRTC)

SCC63484

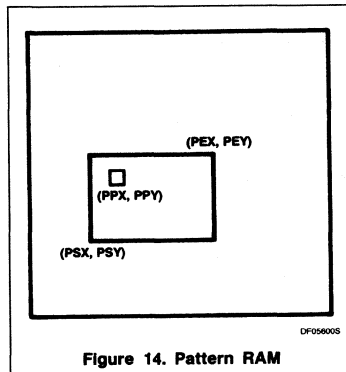

Figure 14. Pattern RAM

AREA	Drawing Area Mode	Description
0 0 0	Drawing is executed without Area checking	
0 0 1	When attempting to exit the area, drawing is stopped after setting ABT (abort bit)	
0 1 0	Drawing suppressed outside the area — drawing operation continues and the ARD flag is not set	
0 1 1	Drawing suppressed outside the area — drawing operation continues and the ARD flag is set at every drawing operation.	
1 0 0	Same as area = 000	
1 0 1	When attempting to enter the area, drawing is stopped after setting ABT (abort bit)	
1 1 0	Drawing suppressed inside the area — drawing operation continues and the ARD flag is not set.	
1 1 1	Drawing suppressed inside the area — drawing operation continues and the ARD flag is set at every drawing operation.	

## SYSTEM INTERFACE

## Basic Clock

The ACRTC basic clock is 2CLK. 2CLK controls all primary ACRTC display and logic timing parameters. 2CLK, along with the specification of number of bits per logical pixel, the graphic address increment mode, and the display access mode, also determines the video data rate. The basic clock must be input, noting its cycle, max. and min. of "high" and "low" level width.

In any case, care must be taken not to stop the basic clock, fixing it at "high" or "low", nor to use 2CLK line in open state, which can destroy the LSI.

## CRT INTERFACE

## Frame Buffer Access

**Access Modes** — The three ACRTC display memory access modes are single, interleaved and superimposed.

1. Single access mode. A display (or drawing) cycle is defined as two cycles of 2CLK. During the first 2CLK cycle, the frame buffer display or drawing address is output. During the second 2CLK cycle, the frame buffer data is read (display cycles and/or drawing cycles) or written (drawing cycles). In this mode, display and drawing cycles contend for access to the frame buffer. The ACRTC allows the priority to be defined as display priority or drawing priority. If display priority, drawing cycles are only allowed to occur during horizontal/vertical flyback period. So, a 'flashless' display is obtained at the expense of slower drawing. If drawing priority, drawing may occur during display so high-speed drawing is obtained, however the display may flash.
2. Interleaved access mode (dual access mode 0). In this mode, display cycles and drawing cycles are interleaved. A display/drawing cycle is defined as four cycles of 2CLK. During the first 2CLK cycle, the frame buffer display address is output. During the second 2CLK cycle, the display data is read from the frame buffer. During the third 2CLK cycle, the frame buffer drawing address is output. During the fourth 2CLK cycle, the drawing data is read or written. Since there is no contention between display and drawing cycles, a 'flashless' display is obtained while maintaining full drawing speed. However, for a given configuration, frame buffer memory access time must be twice as fast as an equivalent single access mode configuration.
3. Superimposed access mode (dual access mode 1). In this mode, two separate logical screens are accessed during each display cycle. The display cycle is defined as four 2CLK cycles. During the first 2CLK cycle, the background (upper, base or lower) screen frame buffer address is output. During the second 2CLK cycle, the background screen display data is read. During the third 2CLK cycle, the window screen frame buffer address or the drawing frame buffer address is output. During the fourth 2CLK cycle, the window screen display or drawing data is read (display or drawing) or written (drawing). Note that the third and fourth cycles can be used for drawing (similar to inter-

leaved mode) when these cycles are not used for window display.

**Graphic Address Increment Mode (GAI)** — During display operation, the ACRTC can be programmed to control the graphic display address in seven ways, including increment by 1, 2, 4, 8 and 16 words, 1 word every two display cycles and no increment.

**NOTE:**

The SCC63484 (R mask version) does not support 16-word increment mode.

Setting GAI to increment by 2, 4, 8 or 16 words per display cycle achieves linear increases in the video data rate; i.e. for a given configuration setting GAI to 2, 4, 8 or 16 words will achieve 2, 4, 8 or 16 times the video data rate corresponding to GAI = 1. This allows increasing the number of bits/logical pixel and logical pixel resolution while meeting the 2CLK maximum frequency constraint.

Table 7 shows the summary relationship between 2CLK, display access mode, graphic address increment, number of bits/logical pixel, memory access time and video data rate. The frame buffer cycle frequency ( $f_c$ ) is shown by the following equation where:

$f_v$  = Dot Clock

N = No. bits/logical pixel

D = Display access mode 1 for single access mode 2 for interleaved and superimposed access modes

A = Graphic address increment (1/2, 1, 2, 4, 8, 16)

$f_c = (f_v \times N \times D) / (A \times 16)$

## DYNAMIC RAM REFRESH

When dynamic RAMs (DRAMs) are used for the frame buffer memory, the ACRTC can automatically provide DRAM refresh addressing. The ACRTC maintains an 8-bit DRAM refresh counter which is decremented on each frame buffer access. During HSYNC low, the ACRTC will output the sequential refresh addresses on MAD. The refresh address assignment depends on graphic address increment (GAI) mode as shown in Table 8. The ACRTC provides "0" output on the remaining address line of MAD and MA/RA.

DRAM refresh cycle timing must be factored into the determination of HSYNC low pulse width (HSW — specified in units of frame buffer memory cycles). If the horizontal scan rate is  $f_h$  (kHz), number of DRAM refresh cycles is N and the DRAM refresh cycle time is  $t_r$  (ms) then horizontal sync width (HSW) is specified by the following equation:

$$HWY \geq N / (t_r \times f_h)$$

# Advanced CRT Controller (ACRTC)

SCC63484

**Table 7. Graphic Address Increment Modes**

DOT RATE ACCESS MODE		16MHz		32MHz		64MHz		128MHz	
Color No. (Bit/Pixel)	Memory Cycle	S	D	S	D	S	D	S	D
1	250ns	—	+ 1/2	+ 1/2	+1	+1	+2	+2	+4
	500ns	+ 1/2	+1	+1	+2	+2	+4	+4	+8
2	250ns	+ 1/2	+1	+1	+2	+2	+4	+4	+8
	500ns	+1	+2	+2	+4	+4	+8	+8	+16
4	250ns	+1	+2	+2	+4	+4	+8	+8	+16
	500ns	+2	+4	+4	+8	+8	+16	+16	—
8	250ns	+2	+4	+4	+8	+8	+16	+16	—
	500ns	+4	+8	+8	+16	+16	—	—	—
16	250ns	+4	+8	+8	+16	+16	—	—	—
	500ns	+8	+16	+16	—	—	—	—	—

For example, if the scan rate is 15.75kHz and the DRAMs have 128 refresh cycles of 2ms, HSW must be greater than or equal to 5.

$$HSW \geq 128 / (2 \times 15.75) = 4.06$$

### EXTERNAL SYNCHRONIZATION

The ACRTC EXSYNC pin allows synchronization of multiple ACRTCs or other video signal generators. The ACRTC may be programmed as a single master device, or as one of a number of slave devices. To synchronize multiple ACRTCs, simply connect all the EXSYNC pins together.

For synchronizing to other video signals, the connection scheme depends on the raster scan mode. In non-interlace mode, EXSYNC corresponds to VSYNC. In interlace modes, EXSYNC corresponds to VSYNC of the odd field (see Figure 15).

#### NOTES:

1. The ACRTC performs the synchronization every time it accepts the pulse input from EXSYNC in the slave mode. It is recommended that the synchronous pulse should be input from EXSYNC only when the synchronization gap between the synchronous signal of the master device and that of ACRTC is in the slave mode. HSYNC and VSYNC are also output in the slave mode.
2. The ACRTC needs to be controlled not to execute the drawing operation during EXSYNC input.

### MPU INTERFACE

#### MPU Bus Cycle

The ACRTC interfaces to the MPU as a peripheral occupying two addresses in the MPU address space. The ACRTC can operate as an 8- or 16-bit peripheral as configured during RES. An MPU bus cycle is initiated when CS is asserted (following the assertion of RS and R $\bar{W}$ ). The ACRTC responds to CS low by asserting DTACK low to complete the

**Table 8. GAI and DRAM Refresh Addressing**

ADDRESS INCREMENT MODE	REFRESH ADDRESS OUTPUT TERMINAL
+0 (GAI = 101)	MAD0 - MAD7
+1 (GAI = 000)	MAD0 - MAD7
+2 (GAI = 001)	MAD1 - MAD8
+4 (GAI = 010)	MAD2 - MAD9
+8 (GAI = 011)	MAD3 - MAD10
+16 (GAI = 100)	MAD4 - MAD11
+ 1/2 (GAI = 111)	MAD0 - MAD7
(GAI = 110)	

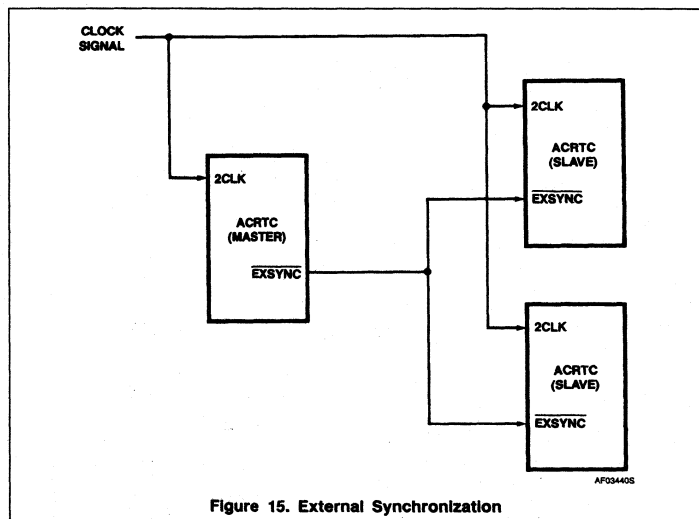

**Figure 15. External Synchronization**

data transfer. DTACK will be returned to the MPU in between 1 and 1.5 2CLK cycles.

MPU WAIT states will be added in the following two cases.

1. If the ACRTC 2CLK input is much slower than the MPU clock, continuous ACRTC

accesses may be delayed due to internal processing of the previous bus cycle. Be careful of CS "high" width.

2. If an ACRTC read cycle immediately follows an ACRTC write cycle, a wait state may occur due to ACRTC prepara-

# Advanced CRT Controller (ACRTC)

SCC63484

tion for bus 'turn-around'. However, (e.g. 68000 system) MPUs normally have no instructions which immediately follow a write cycle with a read cycle.

For connection to synchronous bus interface MPUs,  $\overline{DTACK}$  can simply be left open, assuming the system design guarantees that WAIT states cannot occur as described above. If WAIT states may occur,  $\overline{DTACK}$  can be used with external logic to synthesize a READY signal.

### DMA TRANSFER

The ACRTC can interface with an external DMA controller using three handshake signals. DMA request ( $\overline{DREQ}$ ), DMA acknowledge ( $\overline{DACK}$ ) and DMA done ( $\overline{DONE}$ ). The ACRTC uses the external DMAC for two types of transfers, command/parameter DMA and data DMA. For both types, DMA transfers use the ACRTC read and write FIFOs.

### Command/Parameter DMA

The MPU initiates this mode by setting bit 12 (CDM) in the ACRTC command control register to 1. Then, the ACRTC will automatically request DMA transfer for commands and their associated parameters as long as the write FIFO has space. Only cycle steal request mode ( $\overline{DREQ}$  pulses low for each data transfer) can be used.

Command/parameter DMA is terminated when the MPU resets bit 12 in CCR to 0, or the external  $\overline{DONE}$  input is asserted. Note that the R mask version and the S mask version cannot perform command/parameter DMA transfer, so CDM (bit 12) should be set to 0.

### Data DMA

Data DMA is used to move data between the MPU system memory and the ACRTC frame buffer. The MPU sets up the transfer by specifying the frame buffer transfer address (and other parameters of the transfer, such as 'on-the-fly' logical operations) to the ACRTC. Next, when the MPU issues a data transfer command to the ACRTC, the ACRTC will request DMA transfer to and from system memory. The ACRTC will request DMA, automatically monitoring FIFO status, until the DMA transfer command is completed.

Data DMA request mode can be cycle steal (as in command/parameter DMA), or burst mode in which  $\overline{DREQ}$  is a low-level control output to the DMAC which allows multiple data transfers during each acquisition of the MPU bus.

### INTERRUPTS

The ACRTC recognizes eight separate conditions which can generate an interrupt, including command error detection, command end, December 1986

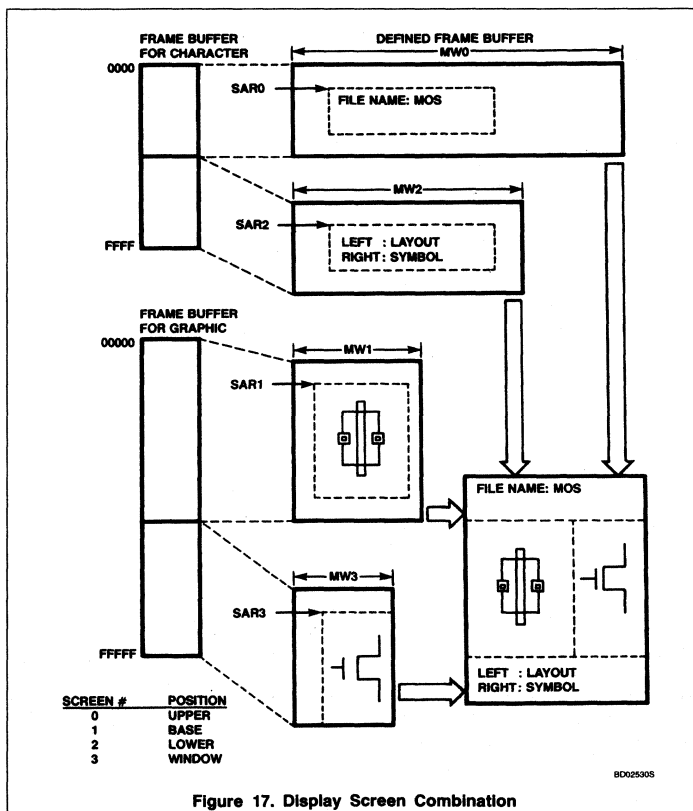
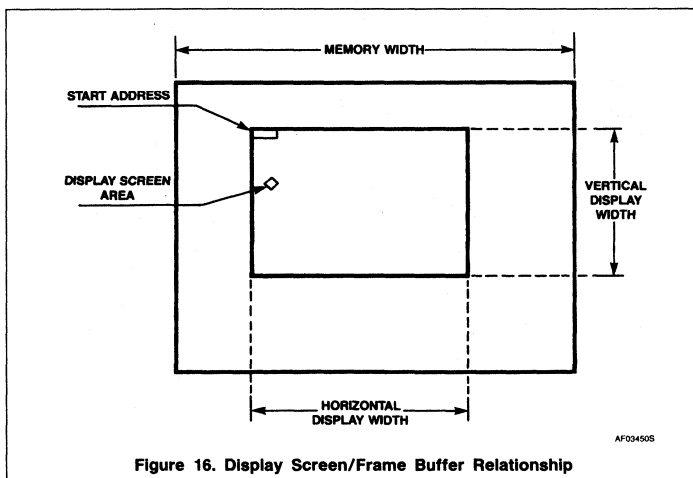

# Advanced CRT Controller (ACRTC)

# SCC63484

# 2

drawing edge detection, light pen strobe, and four FIFO status conditions. Each condition has an associated mask bit for enabling/disabling the associated interrupt. The ACRTC removes the interrupt request when the MPU performs appropriate interrupt service by reading or writing to the ACRTC.

## DISPLAY FUNCTION

### Logical Display Screens

The ACRTC allows division of the frame buffer into four separate logical screens.

Screen Number	Screen Name	Screen Group Name
0	Upper Screen	Background Screens
1	Base Screen	
2	Lower Screen	
3	Window Screen	

In the simplest case, only the base screen parameters must be defined. Other screens may be selectively enabled, disabled and blanked under software control.

The background (upper, base, and lower) screens partition the display into three horizontal splits whose position is fully-programmable. A typical application might use the base screen for the bulk of user interaction, using the lower screen for 'status line(s)' and the upper screen for 'pull-down menu(s)'.

The window screen is unique, since the ACRTC gives the window screen higher priority than background screens. Thus, when the window, whose size and position is fully-programmable, overlaps a background screen, the window screen is displayed. One exception is the ACRTC superimposed access mode, in which the window has the same display priority as background screens. In this case, the window and background screen are 'superimposed' on the display. The ACRTC logical screen organization can be programmed to best suit a number of display applications. See Figures 16 through 18.

### GRAPHIC/CHARACTER ADDRESS SPACES

The ACRTC controls two separate logical address spaces. The CHR pin allows external decoding if physically-separate frame buffers are desired. Each of the four logical screens (upper, base, lower, and window) is programmed as residing in the graphics address space or the character address space (see Figure 19).

ACRTC accesses to graphics screens are treated as bit-mapped using a 20-bit frame buffer address, with an address space of one megaword (1M by 16 bits).

ACRTC accesses to character screens are treated as character generator-mapped. In this case, a 64k word address space is used and five bits of raster address are output to an external character generator (see Figure 20).

Multiple logical screens defined as character can be externally decoded to use separate character generators or different addresses within a combined character generator. Also, each character screen may be defined with separate line spacing, separate cursors, etc.

### CURSOR CONTROL

The ACRTC has two block cursor registers and a graphics cursor register. A block cursor is used with character screens. The cursor start and ending raster addresses are fully-programmable. Also, the cursor width can be defined as one to eight memory cycles.

A graphics cursor is defined by specifying the start/end memory in cycle the X dimension and the start/end raster in the Y dimension. The graphic cursor can output on character screens. The ACRTC provides two separate cursor outputs,  $\overline{CUD1}$  and  $\overline{CUD2}$ . These are combined with two character cursor registers and a graphics cursor register to provide three cursor modes.

#### Block Mode

Two block cursors are output on  $\overline{CUD1}$  and  $\overline{CUD2}$ , respectively (see Figures 21 and 22).

#### Graphic Mode

The graphic cursor is output on  $\overline{CUD1}$ . Using an external cursor pattern memory allows a graphic cursor of various shapes. Two block cursors are multiplexed on  $\overline{CUD2}$  (see Figure 23).

#### Crosshair Mode

The horizontal and vertical components of the graphic cursor are output on  $\overline{CUD1}$  and  $\overline{CUD2}$ , respectively. This allows simple generation of a crosshair cursor control signal (see Figure 24).

### SCROLLING

#### Vertical Scroll

Each logical screen performs independent vertical scroll. On character screens, vertical smooth scroll is accomplished using the programmable start address raster (SAR). Line-

by-line scroll is accomplished by increasing or decreasing the screen start address by one unit of horizontal memory width.

On graphics screens, vertical smooth scroll is accomplished by increasing or decreasing the screen start address by one unit of horizontal memory width (see Figure 25).

#### Horizontal Scroll

Horizontal scroll can be performed in units of characters for character screens and units of words (multi-logical pixels) for graphic screens by increasing or decreasing the screen start address by 1. For smooth horizontal scroll, the ACRTC has dot shift video attributes which can be used with an external circuit which conditions shift register load/clocking.

Since this dot shift information is output each raster, horizontal smooth scroll is limited to either the background screens or the window screen at any given time. However, horizontal smooth scroll is independent for each of the background screens (upper, base, lower). See Figures 25 through 27.

### RASTER SCAN MODES

The ACRTC has three software-selectable raster scan modes — non-interlace, interlace sync, and interlace sync and video. In non-interlace mode, a frame consists of one field. In the interlace modes, a frame consists of two fields, the even and odd fields.

The interlace modes allow increasing screen resolution while avoiding limits imposed by the CRT display device, such as maximum horizontal scan frequency or maximum video dot rate.

Interlace sync mode simply repeats each raster address for both the even and odd fields. This is useful for increasing the quality of a displayed figure when using an interlaced CRT device such as a television set with RF modulator.

Interlace sync and video mode displays alternate even and odd rasters on alternate even and odd fields. For a given number of rasters/character, this mode allows twice as many characters to be displayed in the vertical direction as non-interlace mode (see Figure 28).

Note that for interlace modes, the refresh frequency for a given dot on the screen is one-half that of the non-interlace mode. Interlace modes normally require the use of a CRT with a more persistent phosphor to avoid flickering display.

Advanced CRT Controller (ACRTC)

SCC63484

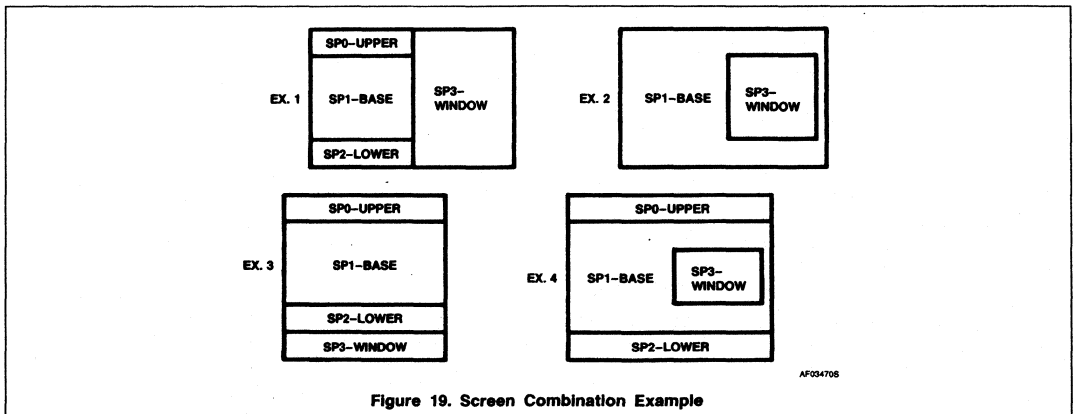
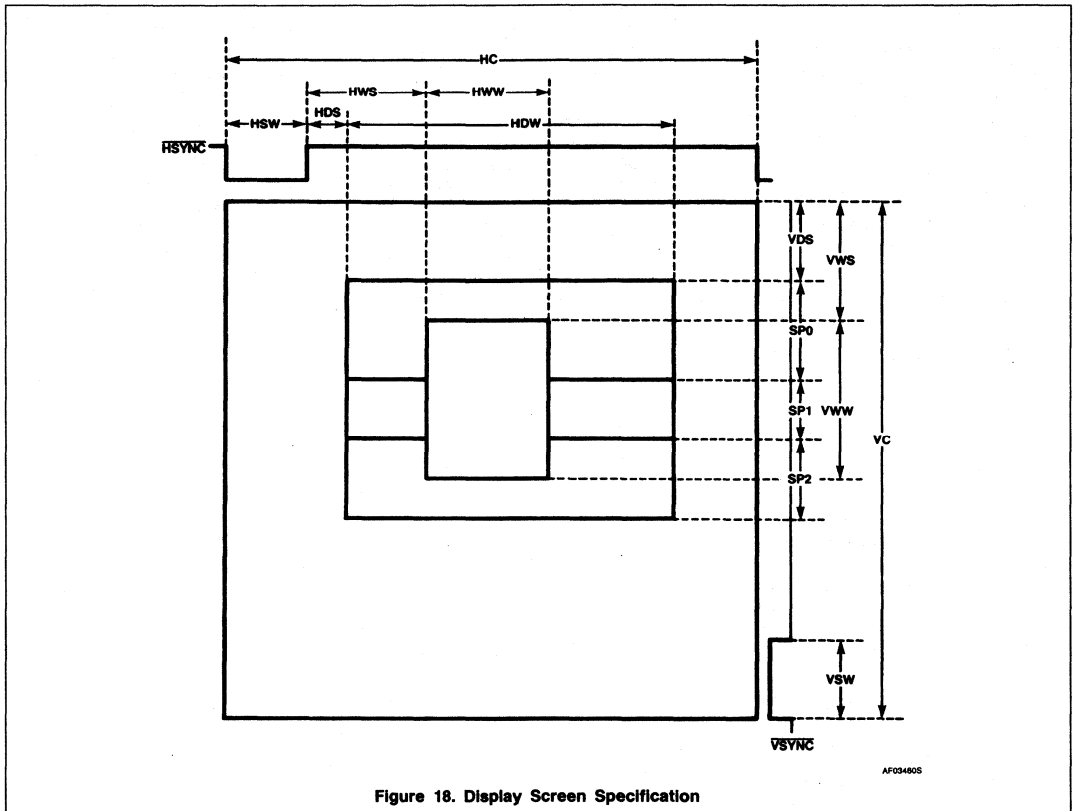



# Advanced CRT Controller (ACRTC)

## SCC63484

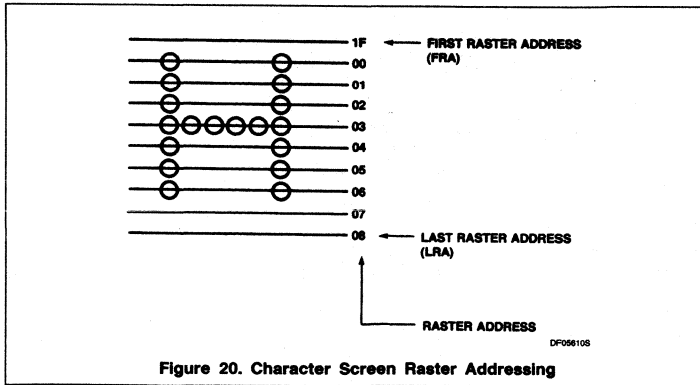

Figure 20. Character Screen Raster Addressing

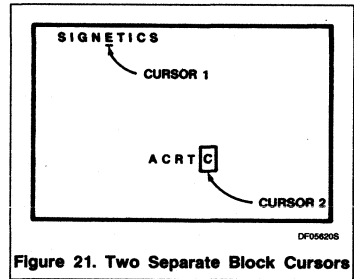

Figure 21. Two Separate Block Cursors

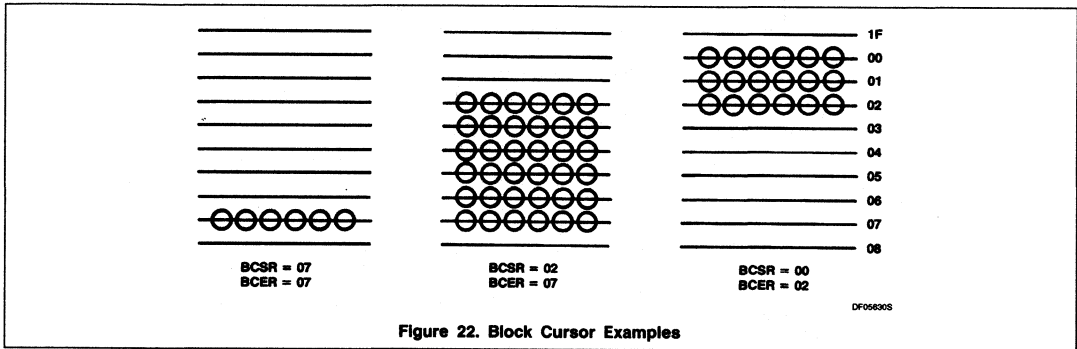

Figure 22. Block Cursor Examples

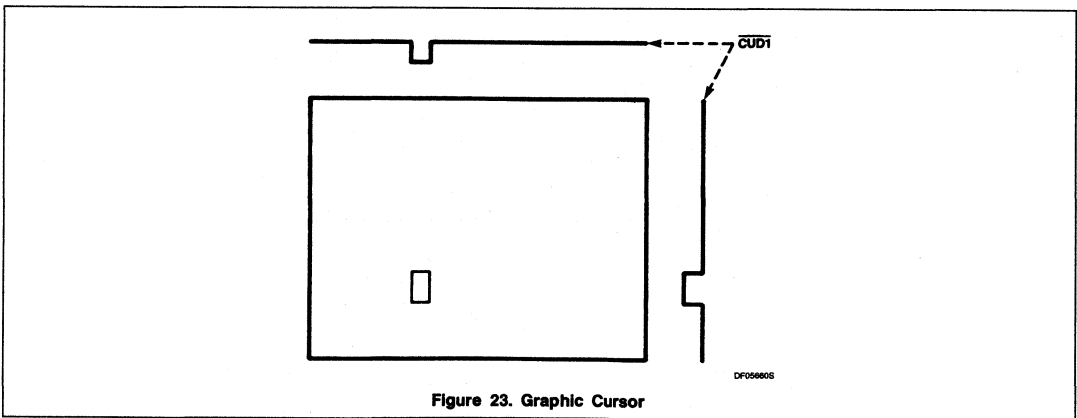

Figure 23. Graphic Cursor

# Advanced CRT Controller (ACRTC)

SCC63484

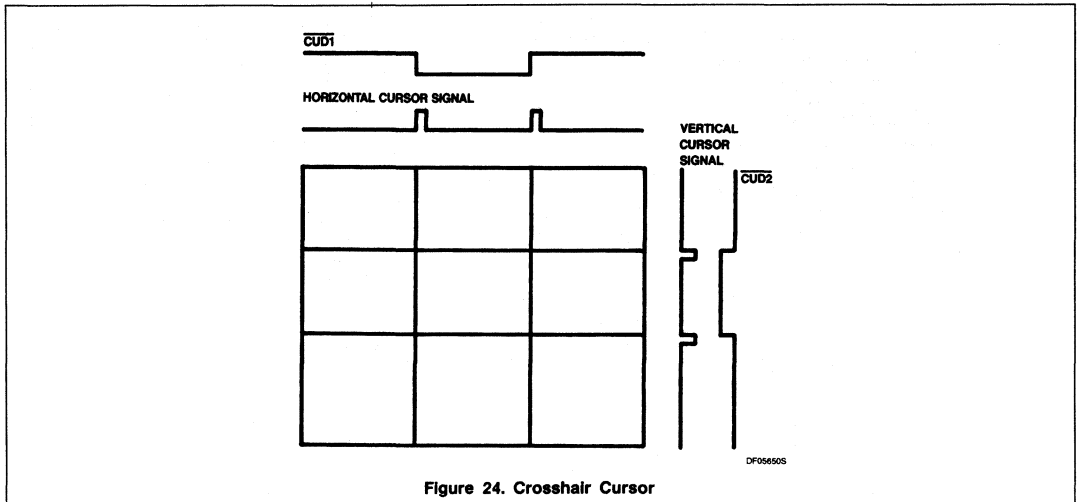

Figure 24. Crosshair Cursor

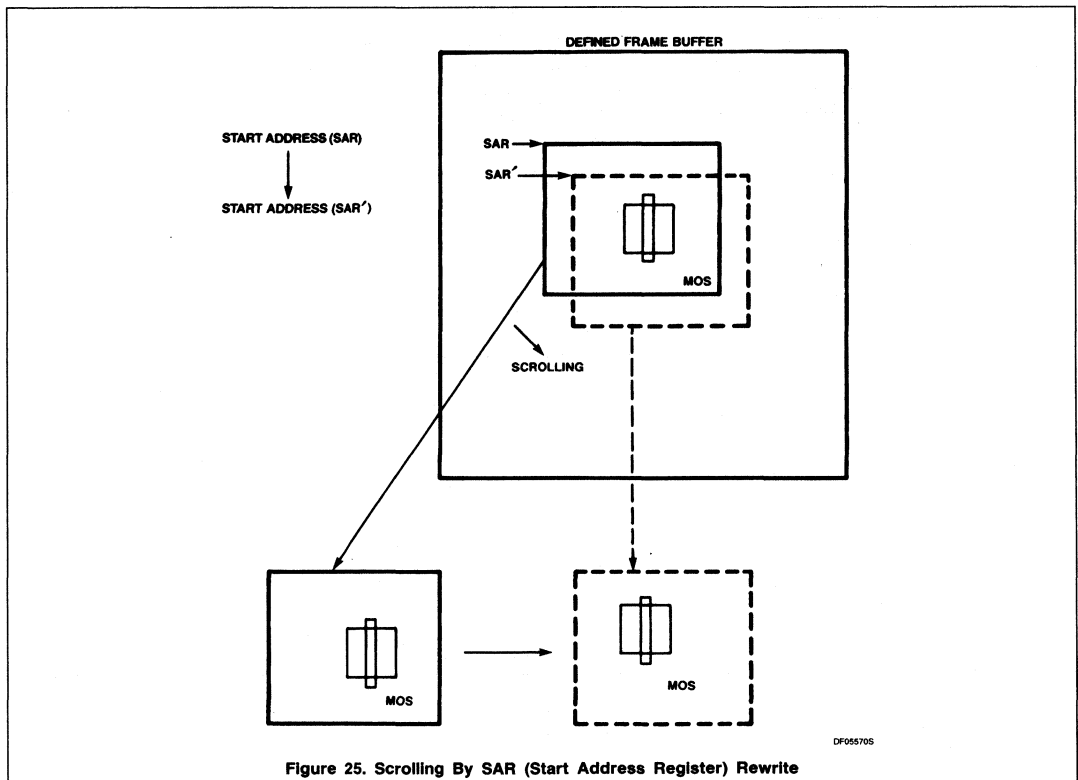

Figure 25. Scrolling By SAR (Start Address Register) Rewrite

Advanced CRT Controller (ACRTC)

SCC63484

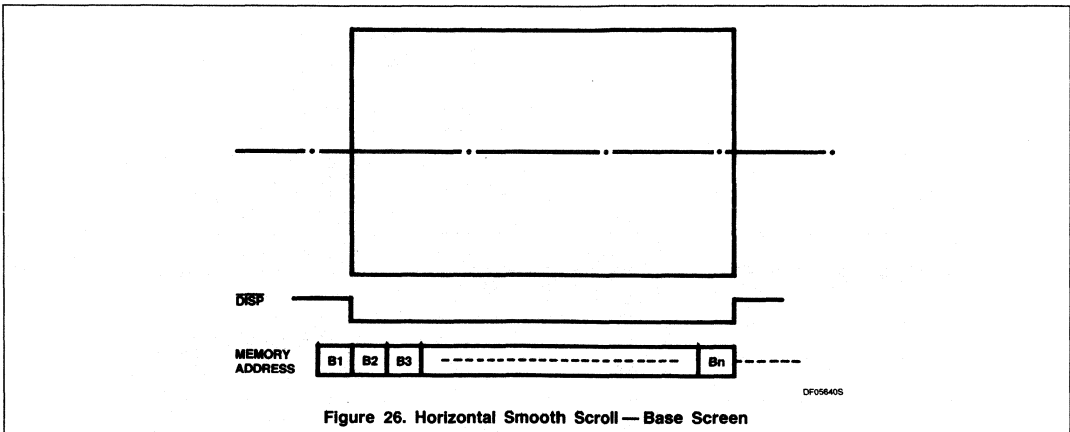

Figure 26. Horizontal Smooth Scroll — Base Screen

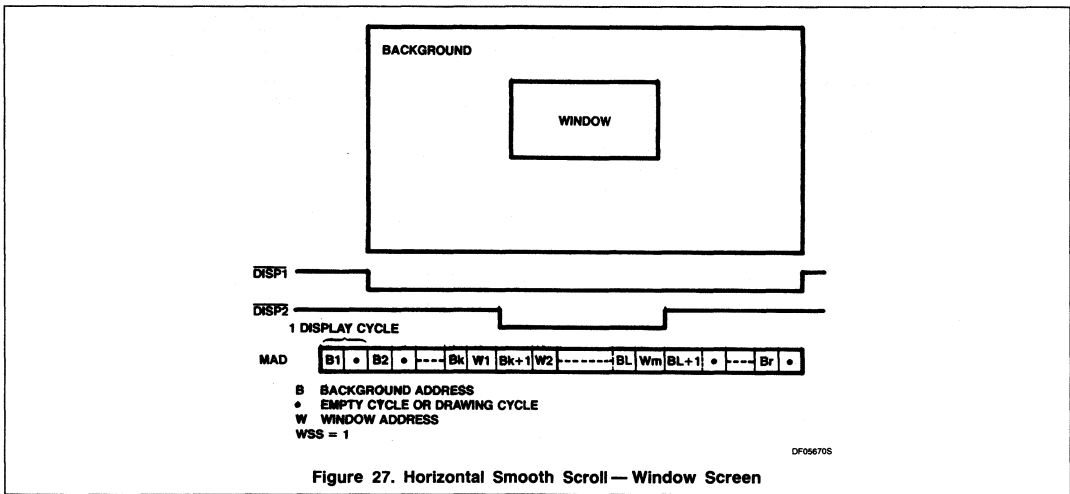
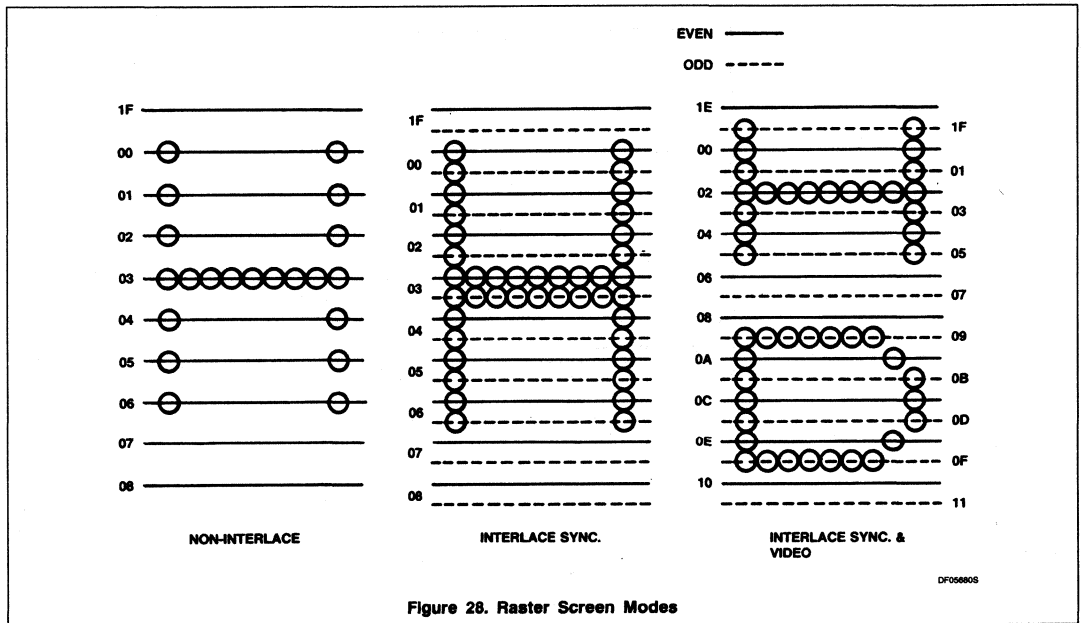

Figure 27. Horizontal Smooth Scroll — Window Screen

B BACKGROUND ADDRESS  
 • EMPTY CYCLE OR DRAWING CYCLE  
 W WINDOW ADDRESS  
 WSS = 1

Advanced CRT Controller (ACRTC)

SCC63484



## Advanced CRT Controller (ACRTC)

SCC63484

**ZOOMING**

The base screen (screen 1) is supported by the ACRTC zooming function. Note that ACRTC zooming is performed by controlling the CRT timing signals. The contents of the frame buffer area being zoomed are not changed. The ACRTC allows specification of a zoom factor (1 to 16) independently in the X and Y directions.

For horizontal zoom, the programmed zoom factor is output as video attributes. An external circuit uses this factor to condition the external shift register clock to accomplish horizontal zooming.

For vertical zoom, no external circuit is required. The ACRTC will scan a single raster

multiple times to accomplish vertical zooming (see Figure 29).

**LIGHT PEN**

The ACRTC provides a 20-bit light pen address register and a light pen strobe (DPSTB) input pin for connection with a light pen.

A light pen strobe pulse will occur when the CRT electron beam passes under the light pen during display refresh. When this pulse occurs, the contents of the ACRTC display refresh address counter will be latched into the light pen address register along with a logical screen (character or graphic screen) designator. Also, an ACRTC status flag indicating light pen activity is set, generating an optional (maskable) MPU interrupt. Note that

for superimposed access mode, when the light pen strobe occurs in an area in which the window overlaps a background (upper, base, or lower) screen, the background screen address will be latched. And even for all access modes, the drawing address will be latched.

Various system and ACRTC delays will cause the latched address to differ slightly from the actual light pen position. The light pen address can be corrected using software, based on system-specific delays. Or, if the application does not require the highest light pen pointing resolution, software can 'bind' the light pen address by specifying a range of values associated with a given area of the screen.

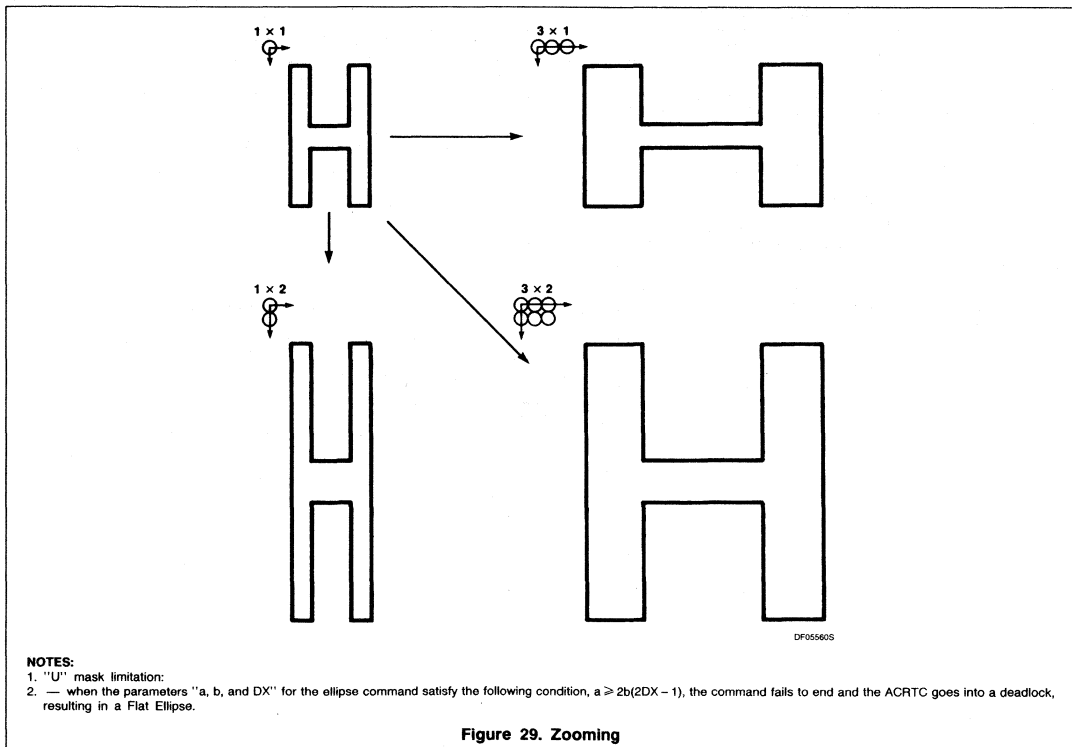

## Advanced CRT Controller (ACRTC)

SCC63484

ABSOLUTE MAXIMUM RATINGS<sup>1</sup>

SYMBOL	PARAMETER	RATING	UNIT
V <sub>S</sub>	Supply voltage <sup>2</sup> range	-0.3 to +7.0	V
V <sub>IN</sub>	Input voltage <sup>2</sup> range	-0.3 to V <sub>CC</sub> + 0.3	V
I <sub>OUT</sub>	Allowable output current <sup>3</sup>	+5	mA
I <sub>OUT</sub>	Total allowable output current <sup>4</sup>	+120	mA
T <sub>A</sub>	Operating temperature range	0 to +70	°C
T <sub>STG</sub>	Storage temperature range	-55 to +150	°C

## RECOMMENDED OPERATING CONDITIONS

SYMBOL	PARAMETER	MIN	TYP	MAX	UNIT
V <sub>S</sub>	Supply voltage <sup>2</sup>	4.75	5	5.25	V
V <sub>IL</sub>	Input low level voltage <sup>2</sup>	0	-	0.7	V
V <sub>IH</sub>	Input high level voltage <sup>2</sup>	2.2	-	V <sub>CC</sub>	V
T <sub>A</sub>	Operating temperature	0	25	70	°C

## NOTES:

- Using an LSI beyond its maximum ratings may result in permanent destruction. LSIs should usually be used under recommended operating conditions. Exceeding any of these conditions may adversely affect the LSI's reliability.
- This value is in reference to V<sub>SS</sub> = 0V.
- The allowable output current is the maximum current that may be drawn from, or flow out to one output terminal or one input/output common terminal.
- The total allowable output current is the total sum of currents that may be drawn from, or flow out to output terminals or input/output common terminals.

## TIMING MEASUREMENT

The timing measurement point for the output "low" level is defined at 0.8V throughout this specification. The output "low" level at stable condition (DC characteristics) is defined at 0.5V. The output "high" level is defined at V<sub>CC</sub> - 2.0V (see Figure 30).

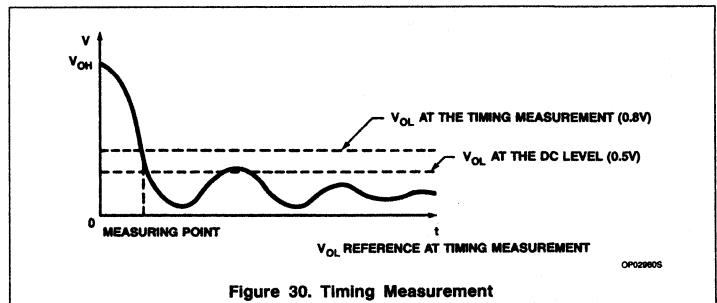

## Advanced CRT Controller (ACRTC)

SCC63484

**DC ELECTRICAL CHARACTERISTICS**  $V_{CC} = 5V \pm 5\%$ ,  $V_{SS} = 0V$ ,  $T_A = 0$  to  $+70^\circ C$  unless otherwise noted.

PARAMETER		TEST CONDITIONS	8MHz		UNIT
			Min	Max	
Input high level	All inputs		2.2	$V_{CC}$	V
Input low level	All inputs		-0.3	0.7	V
Input leakage current	R/W, $\overline{CS}$ , RS, $\overline{RES}$ , $\overline{DACK}$ 2CLK, LPSTB	$V_{IN} = 0 - V_{CC}$	-2.5	2.5	$\mu A$
3-State (off-state) input current	D0 - D15, EXSYNC, MAD0 - MAD15	$V_{IN} = 0.4 - V_{CC}$	-10	10	$\mu A$
Output high level	D0 - D15, MAD0 - MAD15, $\overline{CUD1}$ , $\overline{CUD2}$ DREQ, DTACK, HSYNC, VSYNC, EXSYNC	$I_{OH} = -400\mu A$	$V_{CC}$ -1	—	V
Output low level	DISPT, DISP2 CHR, MRD, DRAW, AS, MCYC, RA4, MA16/RA0, MA19/RA3	$I_{OL} = 2.2mA$	—	0.5	V
Output leakage current (off-state)	$\overline{IRQ}$ , $\overline{DONE}$	$V_{OH} = V_{CC}$	—	10	$\mu A$
Input capacity	D0 - D15, EXSYNC, MAD0 - MAD15 R/W, $\overline{CS}$ , RS, $\overline{RES}$ , $\overline{DACK}$ , 2CLK, LPSTB	$V_{IN} = 0V$ , $T_A = 25^\circ C$ , $f = 1.0MHz$	—	17	pF
Output capacity	$\overline{IRQ}$ , $\overline{DONE}$	$V_{IN} = 0V$ , $T_A = 25^\circ C$ , $f = 1.0MHz$	—	15	pF
Current Consumption		Chip not selected	—	100	mA
		Display in progress Data bus in read/write operation Display in progress Command execution in progress	—	100	mA

2

## Advanced CRT Controller (ACRTC)

SCC63484

**AC ELECTRICAL CHARACTERISTICS**  $V_{CC} = 5V \pm 5\%$ ,  $V_{SS} = 0V$ ,  $T_A = 0$  to  $+70^\circ C$  unless otherwise noted.

NO.	FIGURE	CHARACTERISTIC	TENTATIVE LIMITS		UNIT
			8MHz		
			Min	Max	
		Operation frequency of 2CLK	1	8	MHz
1	41	Clock cycle time	125	1000	ns
2	41	Clock high level pulse width	55	500	ns
3	41	Clock low level pulse width	55	500	ns
4	41	Clock rise time	—	10	ns
5	41	Clock fall time	—	10	ns
6	42, 43	R/W setup time	50	—	ns
7	42, 43	R/W hold time	0	—	ns
8	42, 43	RS setup time	50	—	ns
9	42, 43	RS hold time	0	—	ns
10	42, 43	$\overline{CS}$ setup time	40	—	ns
11	42, 43	$\overline{CS}$ high level width	60	—	ns
13	42	Read wait time	0	—	ns
14	42	Read data access time	—	80	ns
15	42	Read data hold time	10	—	ns
16	42	Read data turn off time	—	60	ns
17	42, 43	$\overline{DTACK}$ delay time (Z to L)	—	70	ns
18	42	$\overline{DTACK}$ delay time (D to L)	0	—	ns
19	42, 43	$\overline{DTACK}$ release time (L to H)	—	80	ns
20	42, 43	$\overline{DTACK}$ turn off time (H to Z)	—	100	ns
21	42	Data bus 3-State recovery time 1	0	—	ns
22	43	Write wait time	0	—	ns
23	43	Write data setup time	40	—	ns
24	43	Write data hold time	10	—	ns
25	44, 45	$\overline{DREQ}$ delay time 1	—	110	ns
26	44, 45	$\overline{DREQ}$ delay time 2	—	70	ns
27	44, 45	DMA R/W setup time	50	—	ns
28	44, 45	DMA R/W hold time	0	—	ns
29	44, 45	$\overline{DACK}$ setup time	40	—	ns
30	44, 45	$\overline{DACK}$ high level width	60	—	ns
32	44	DMA read wait time	0	—	ns
33	44	DMA read data access time	—	80	ns
34	44	DMA read data hold time	10	—	ns
35	44	DMA read data turn off time	—	60	ns
36	44, 45	DMA $\overline{DTACK}$ delay time (Z to L)	—	70	ns
37	44	DMA $\overline{DTACK}$ delay time (D to L)	0	—	ns
38	44, 45	DMA $\overline{DTACK}$ release time (L to H)	—	80	ns
39	44, 45	DMA $\overline{DTACK}$ turn off time (H to Z)	—	100	ns
40	44, 45	$\overline{DONE}$ output delay time	—	70	ns



## Advanced CRT Controller (ACRTC)

SCC63484

**2**

## AC ELECTRICAL CHARACTERISTICS (Continued)

NO.	FIGURE	CHARACTERISTIC	TENTATIVE LIMITS		UNIT
			8MHz		
			Min	Max	
41	44, 45	DONE output turn off time (L to Z)	—	80	ns
42	44	Data bus 3-State recovery time 2	0	—	ns
43	44, 45	DONE input pulse width	2	—	Clk Cyc
44	45	DMA write wait time	0	—	ns
45	45	DMA write data setup time	40	—	ns
46	45	DMA write data hold time	10	—	ns
48	46-49	$\overline{AS}$ low level pulse width	25	—	ns
49	47, 48	Memory address hold time 2	10	—	ns
50	46-49	$\overline{AS}$ delay time 1	—	60	ns
51	46-49	$\overline{AS}$ delay time 2	—	60	ns
52	46-49	Memory address delay time	—	70	ns
53	46-49	Memory address hold time 1	10	—	ns
54	46, 47, 49	Memory address turn off time (A to Z)	—	50	ns
55	47	Memory address data setup time	40	—	ns
56	47	Memory read data hold time	10	—	ns
57	46-49	MA/RA delay time	—	80	ns
58	46-48	MA/RA hold time	10	—	ns
59	46-50	MCYC delay time	—	50	ns
60	46-49	MRD delay time	—	70	ns
61	46-49	MRD hold time	10	—	ns
62	46-49	DRAW delay time	—	70	ns
63	46-49	DRAW hold time	10	—	ns
64	48	Memory write data delay time	—	70	ns
65	48	Memory write data hold time	10	—	ns
67	49-51	HSYNC delay time	—	70	ns
68	50	VSYNC delay time	—	70	ns
69	50	$\overline{DISP1}$ , $\overline{DISP2}$ delay time	—	70	ns
70	50	$\overline{CUD1}$ , $\overline{CUD2}$ delay time	—	70	ns
71	50	EXSYNC output delay time	20	70	ns
72	50	CHR delay time	—	70	ns
75	51	EXSYNC input pulse width	3	—	Clk Cyc
76	51	EXSYNC input setup time 1	50	—	ns
77	51	EXSYNC input hold time	30	—	ns
78	52	LPSTB uncertain time 1	70	—	ns
79	52	LPSTB uncertain time 2	10	—	ns
80	52	LPSTB input hold time	10	—	ns
81	52	LPSTB input inhibit time	4	—	Clk Cyc
82	53	$\overline{DACK}$ setup time for $\overline{RES}$	100	—	ns
83	53	$\overline{DACK}$ hold time for $\overline{RES}$	0	—	ns

# Advanced CRT Controller (ACRTC)

# SCC63484

## AC ELECTRICAL CHARACTERISTICS (Continued)

NO.	FIGURE	CHARACTERISTIC	TENTATIVE LIMITS		UNIT
			8MHz		
			Min	Max	
84	53	$\overline{RES}$ input pulse width	10	—	Clk Cyc
85	54	$\overline{IRQ}$ delay time 1	—	150	ns
86	54	$\overline{IRQ}$ delay time 2	—	500	ns
87	49	ATR delay time 1	—	80	ns
88	49	ATR hold time 1	10	—	ns
90	49	ATR delay time 2	—	80	ns
91	49	ATR hold time 2	10	—	ns
100	42, 43	$\overline{CS}$ cycle time	4	—	Clk Cyc
101	42, 43	$\overline{CS}$ low level width	2	—	Clk Cyc
102	42, 43	$\overline{CS}$ high level width	2	—	Clk Cyc
104	44 45	$\overline{DACK}$ cycle time	4	—	Clk Cyc
105	44, 45	$\overline{DACK}$ low level width	2	—	Clk Cyc
106	44, 45	$\overline{DACK}$ high level width	2	—	Clk Cyc

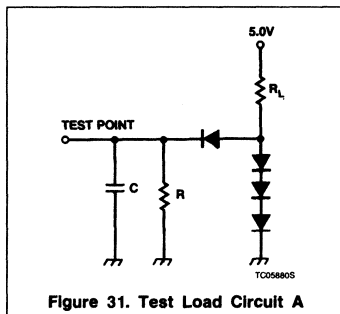

Figure 31. Test Load Circuit A

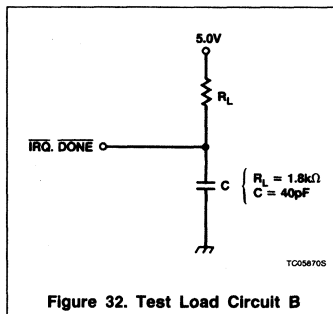

Figure 32. Test Load Circuit B

### Power-On Sequence

The following condition needs to be satisfied when the power turns on.

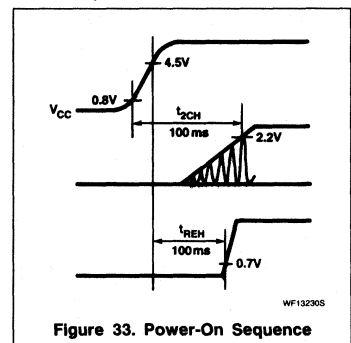

Figure 33. Power-On Sequence

### Signal

D0 - D15  
 $\overline{DTACK}$   
 $\overline{DREQ}$   
 MAD0 - MAD15  
 MA16/RA0 - MA19/  
 RA3  
 RA4  
 $\overline{VSYNC}$ , HSYNC  
 $\overline{EXSYNC}$   
 $\overline{MCYC}$ ,  $\overline{AS}$ , MRD  
 $\overline{DRAW}$ , CHR  
 $\overline{DISP1}$ ,  $\overline{DISP2}$   
 $\overline{CUD1}$ ,  $\overline{CUD2}$

### Load Condition

$R_L = 1.84\Omega$   
 $C = 40pF$

$R = 10k\Omega$

All diodes are 1S2074 or equivalent

# Advanced CRT Controller (ACRTC)

SCC63484

## Output Waveform

In case that ringing noise occurs beyond tolerance on the CRT data buses (MAD0 - MAD15, MA16/RA0 - MA19/RA2, RA4), damping resistors may be required for data buses as shown in Figures 34 and 35.

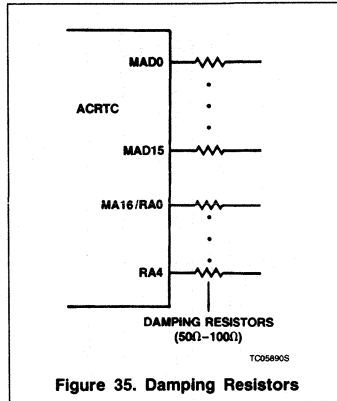
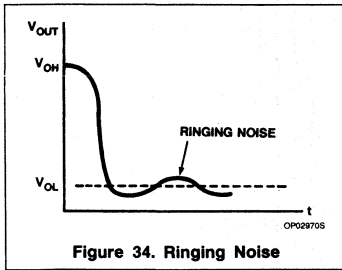

## Power Supply Circuit

When designing the  $V_{CC}$  and  $V_{SS}$  pattern of the circuit board, the capacitors need to be located nearest to pin 14 ( $V_{CC}$ ) and pin 16 ( $V_{SS}$ ) or pin 51 ( $V_{SS}$ ) and pin 49 ( $V_{CC}$ ), as shown in Figure 36.

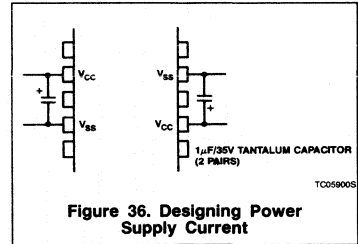

2

Advanced CRT Controller (ACRTC)

SCC63484

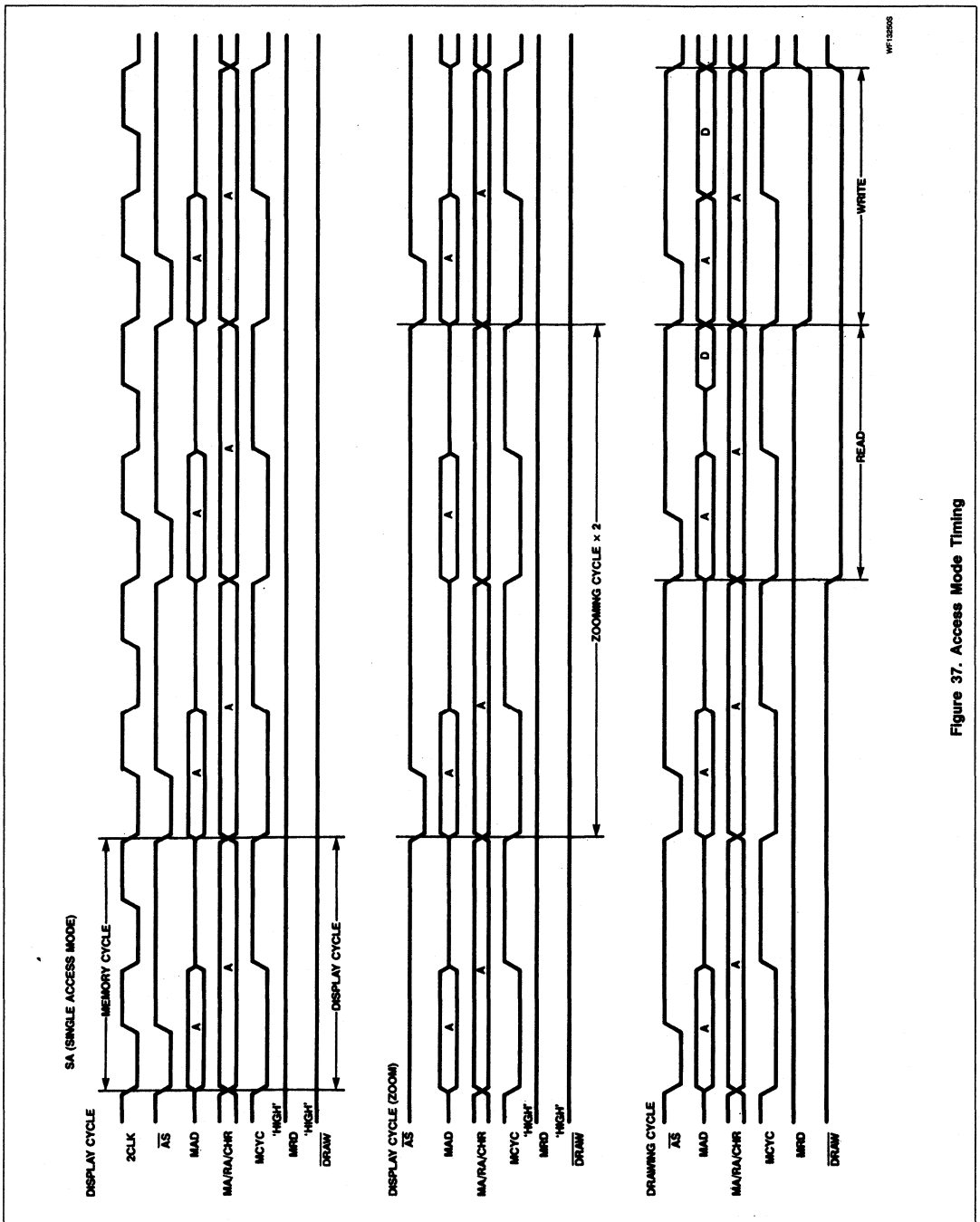

Figure 37. Access Mode Timing

# Advanced CRT Controller (ACRTC)

SCC63484

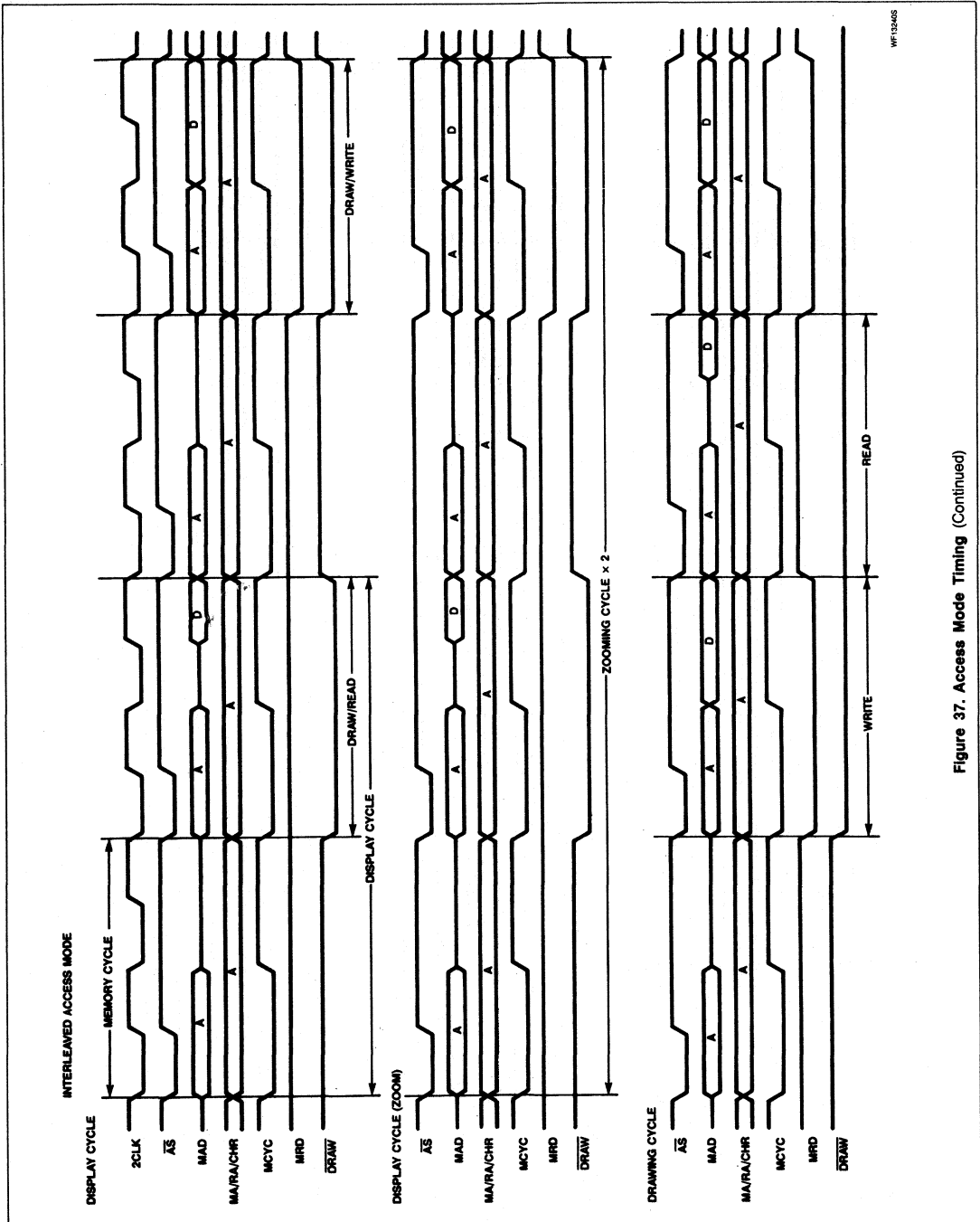

Figure 37. Access Mode Timing (Continued)

# Advanced CRT Controller (ACRTC)

## SCC63484

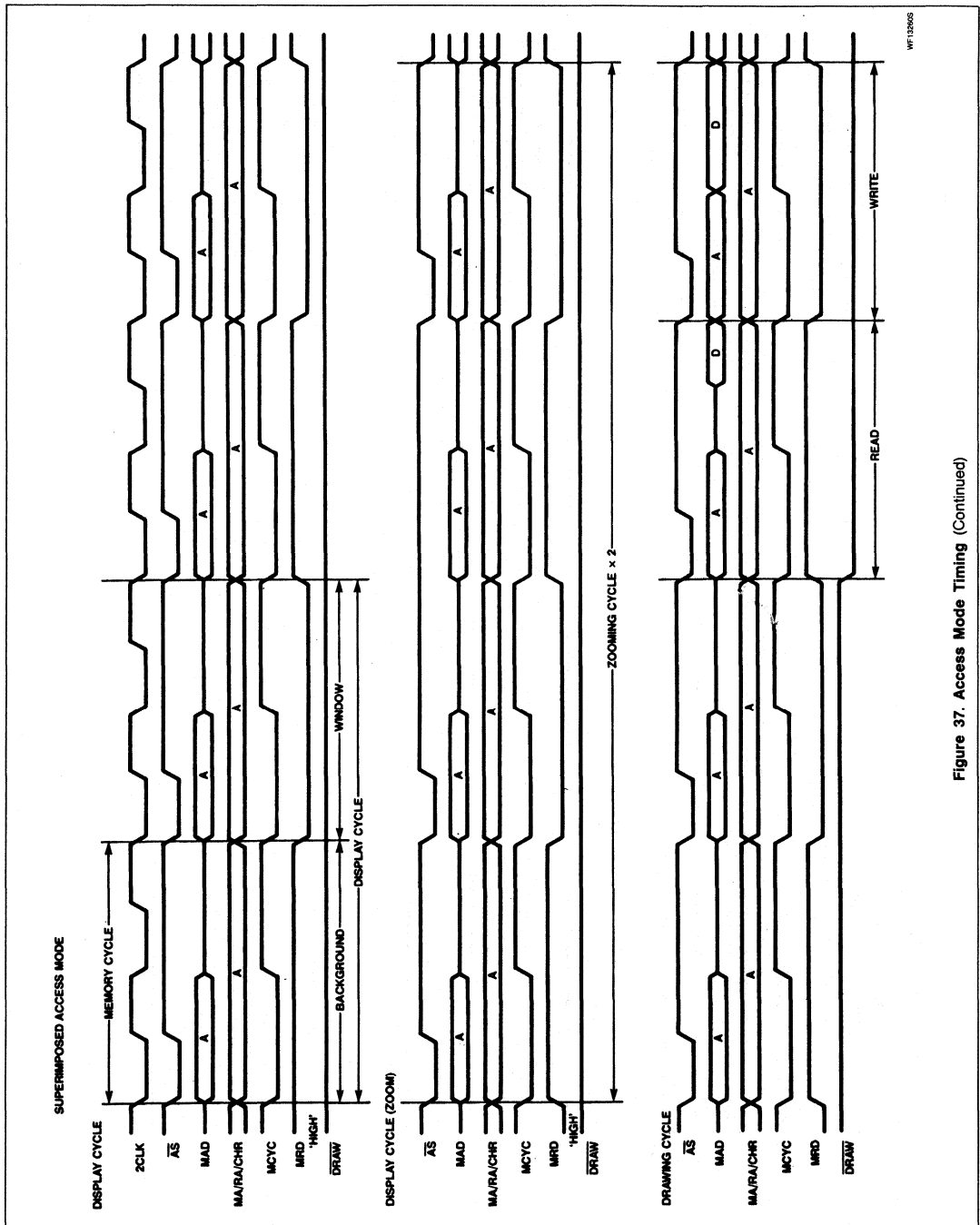
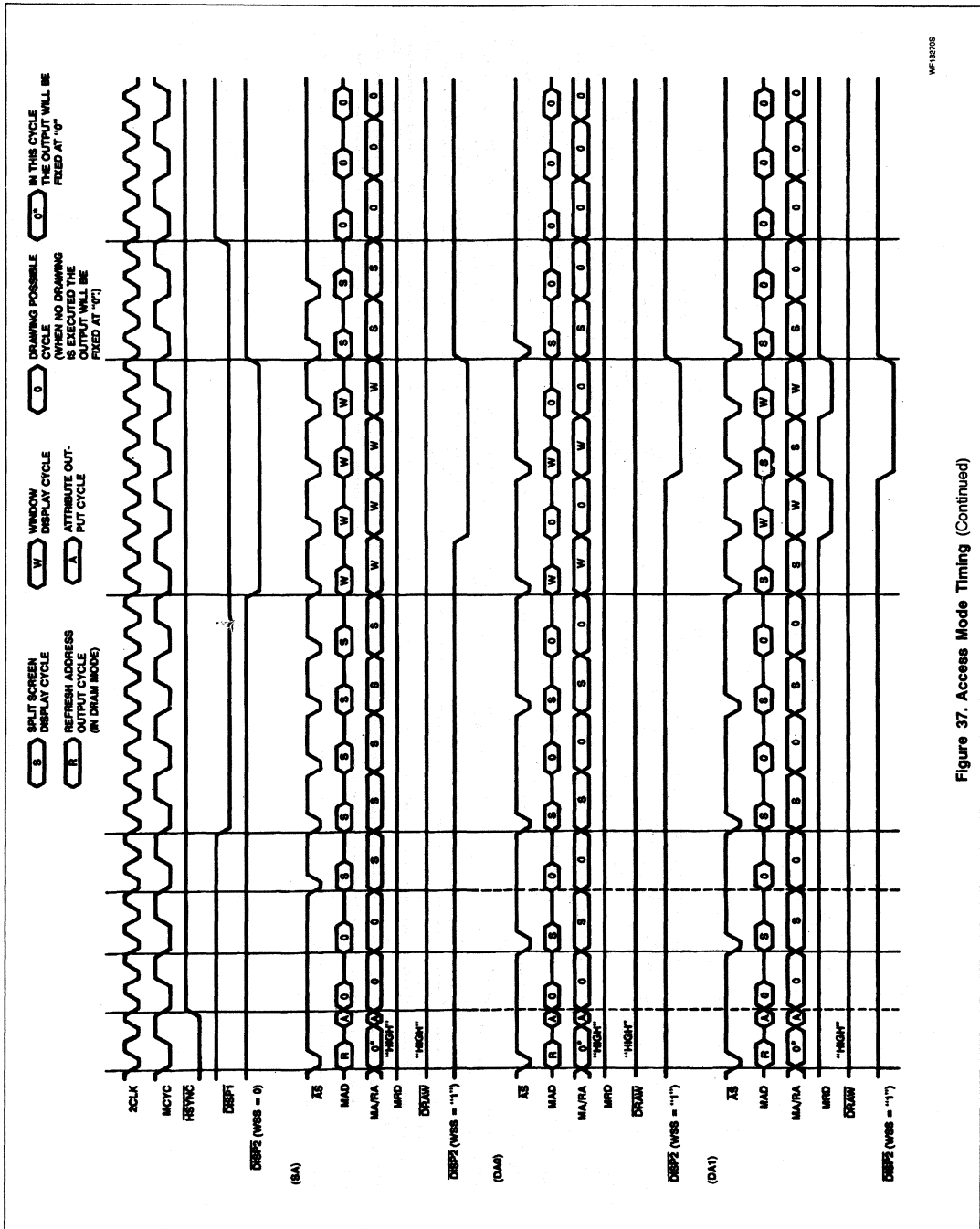

Figure 37. Access Mode Timing (Continued)

Advanced CRT Controller (ACRTC)

SCC63484



WF 182705

Figure 37. Access Mode Timing (Continued)

Advanced CRT Controller (ACRTC)

SCC63484

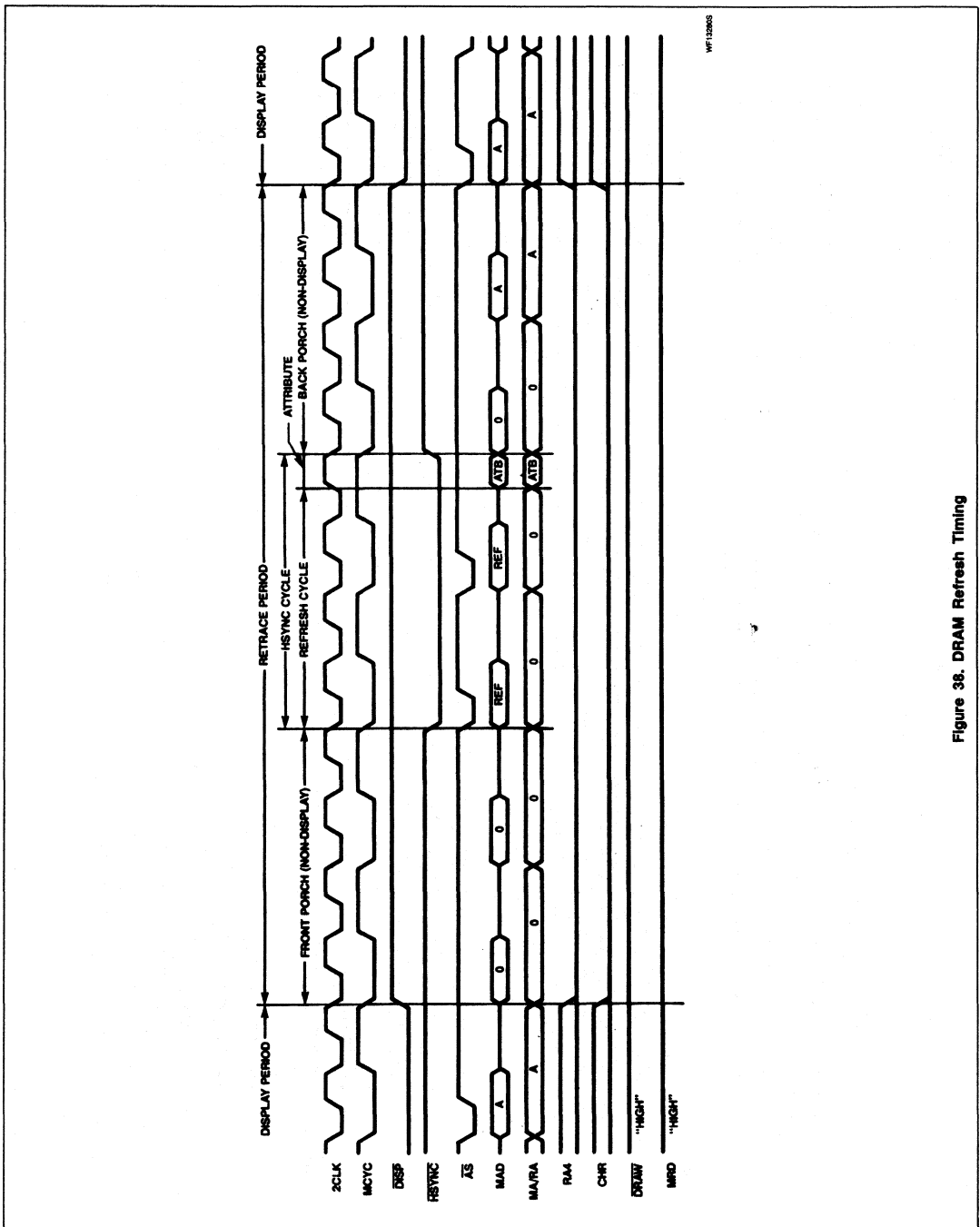

WF1206S

Figure 38. DRAM Refresh Timing



Advanced CRT Controller (ACRTC)

SCC63484

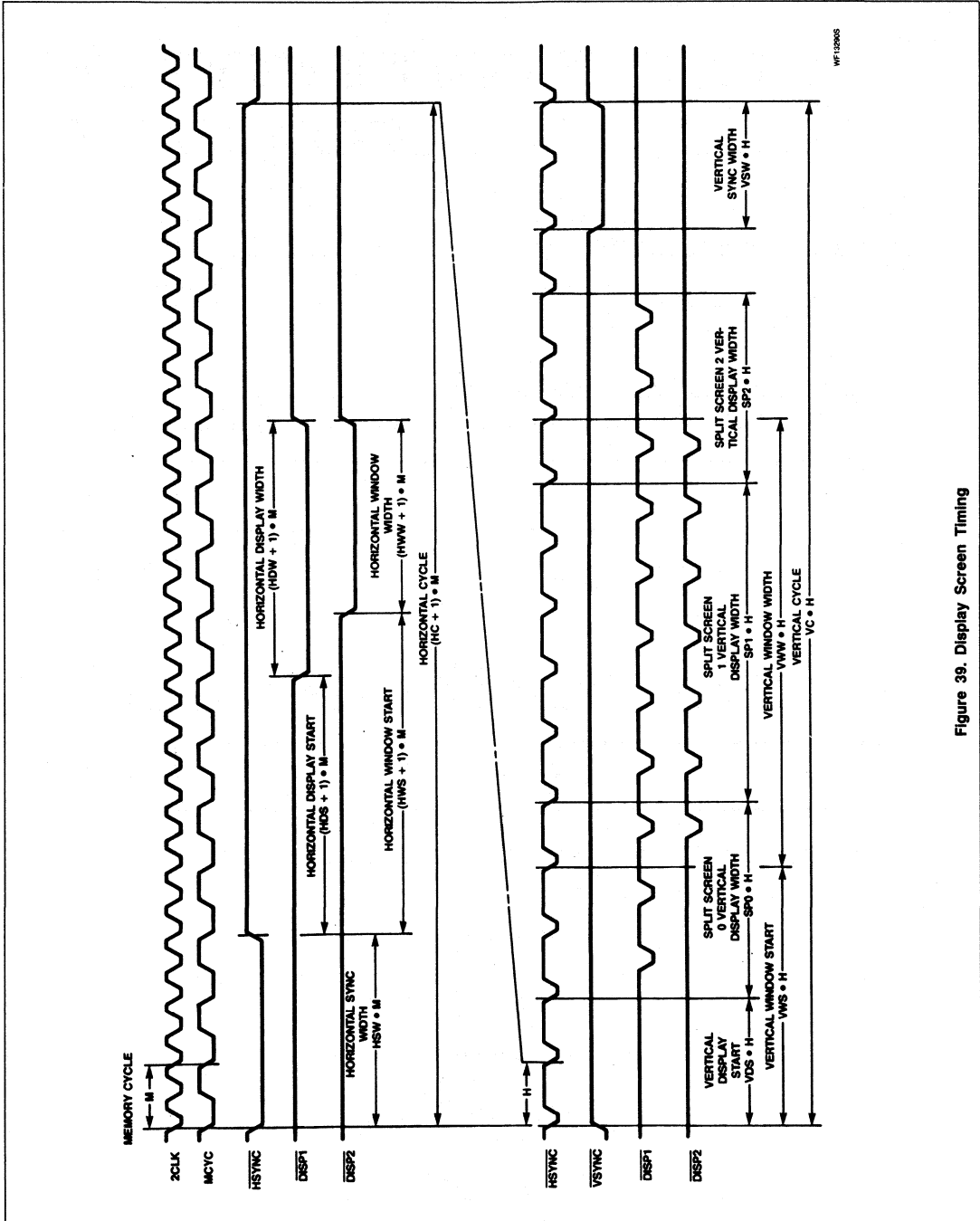

Figure 39. Display Screen Timing

Advanced CRT Controller (ACRTC)

SCC63484

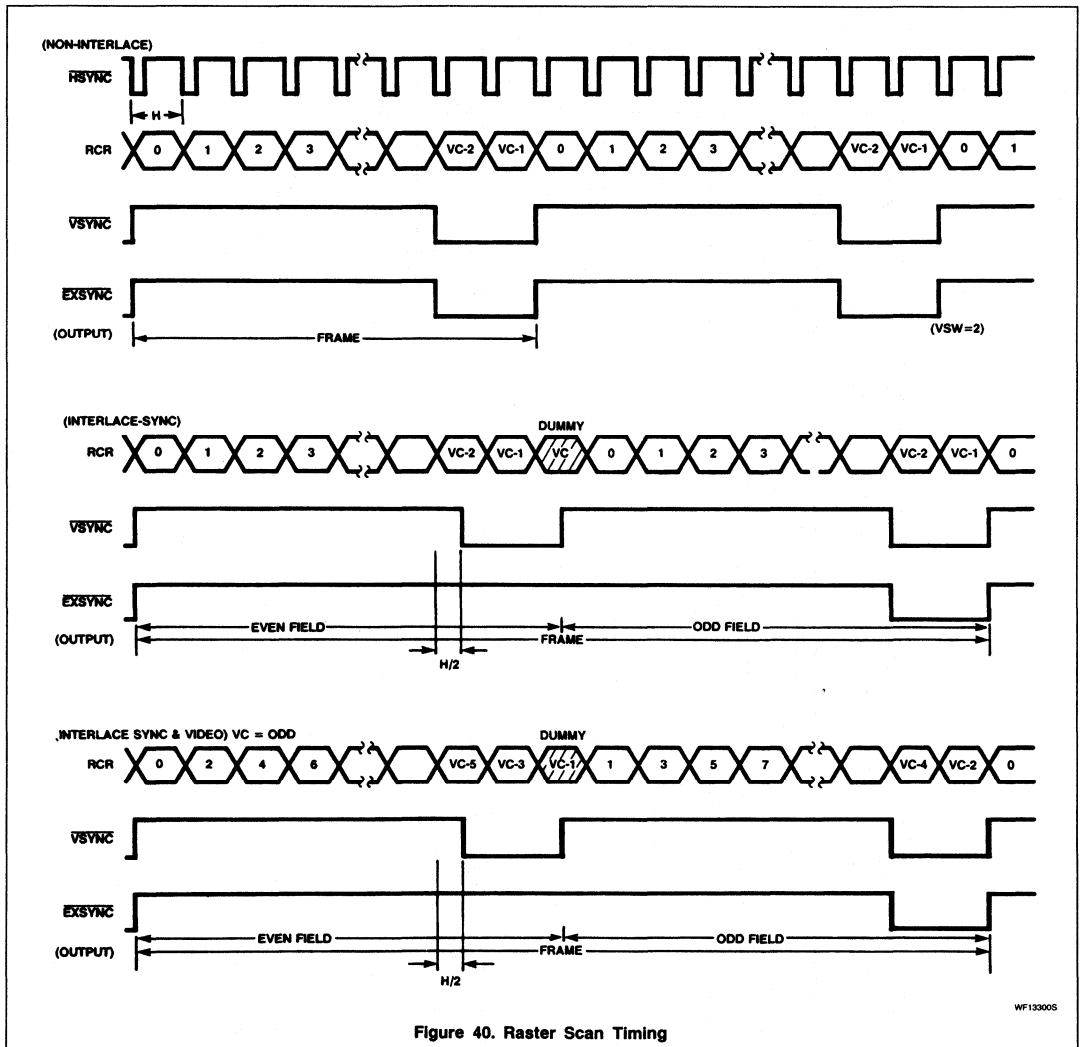

Figure 40. Raster Scan Timing

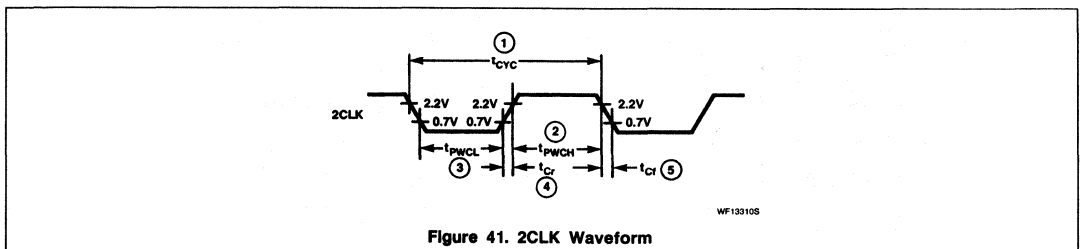
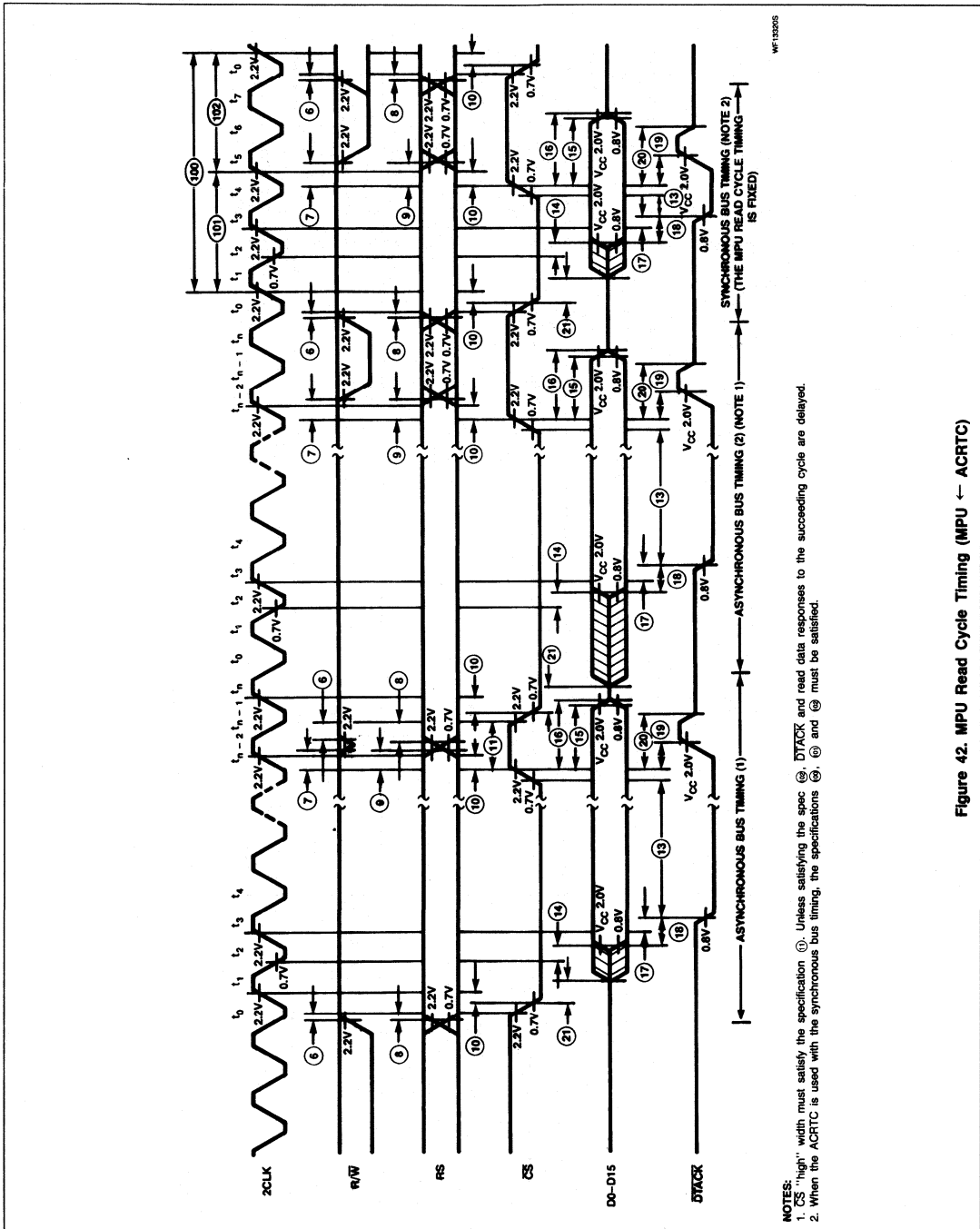

Figure 41. 2CLK Waveform

Advanced CRT Controller (ACRTC)

SCC63484



WF13265

NOTES:  
 1. CS "high" width must satisfy the specification (1). Unless satisfying the spec (1), DTACK and read data responses to the succeeding cycle are delayed.  
 2. When the ACRTC is used with the synchronous bus timing, the specifications (1), (2), (3), (4), (5), (6), (7), (8), (9), (10), (11), (12), (13), (14), (15), (16), (17), (18), (19), (20), (21) must be satisfied.

Figure 42. MPU Read Cycle Timing (MPU ← ACRTC)

# Advanced CRT Controller (ACRTC)

## SCC63484

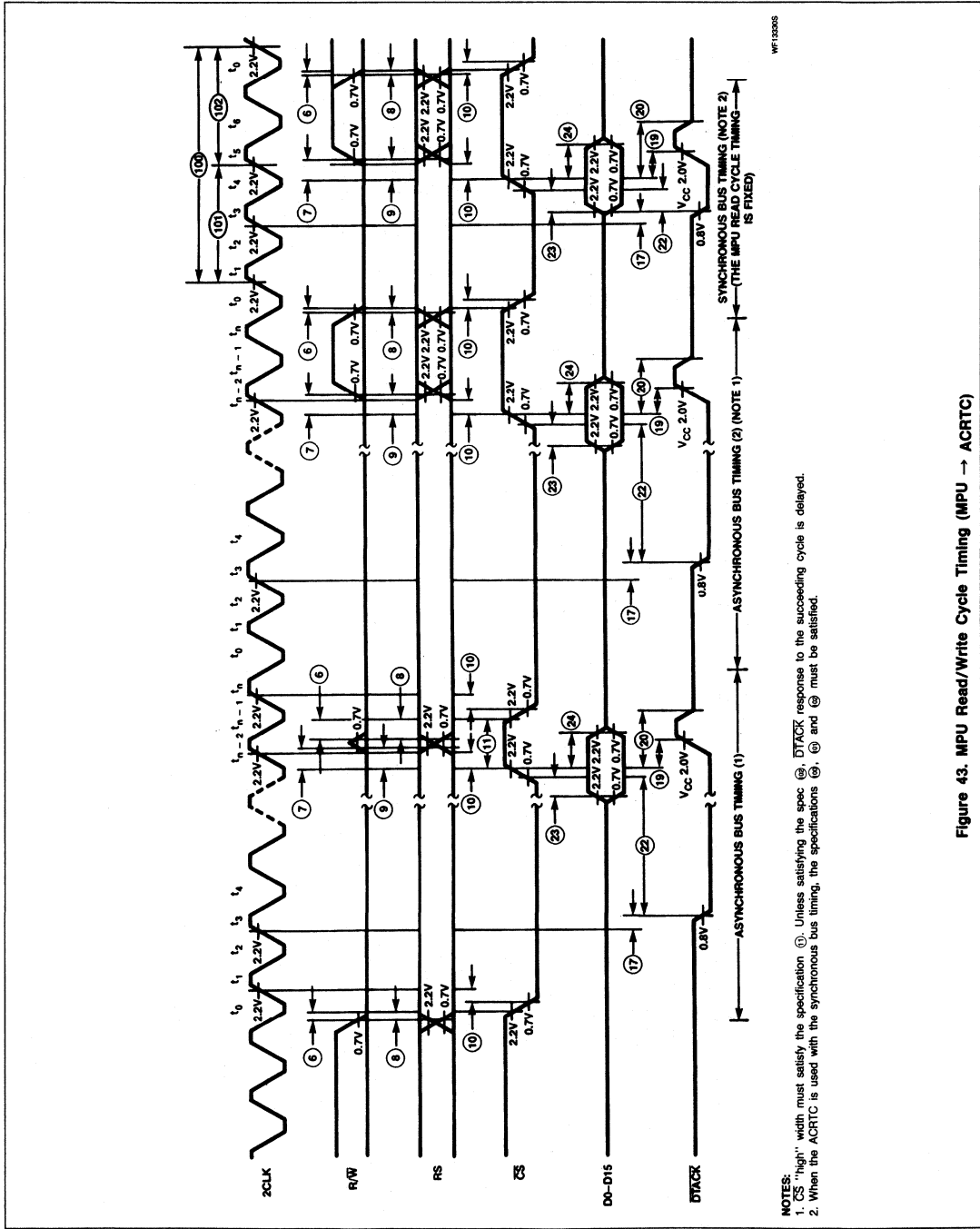
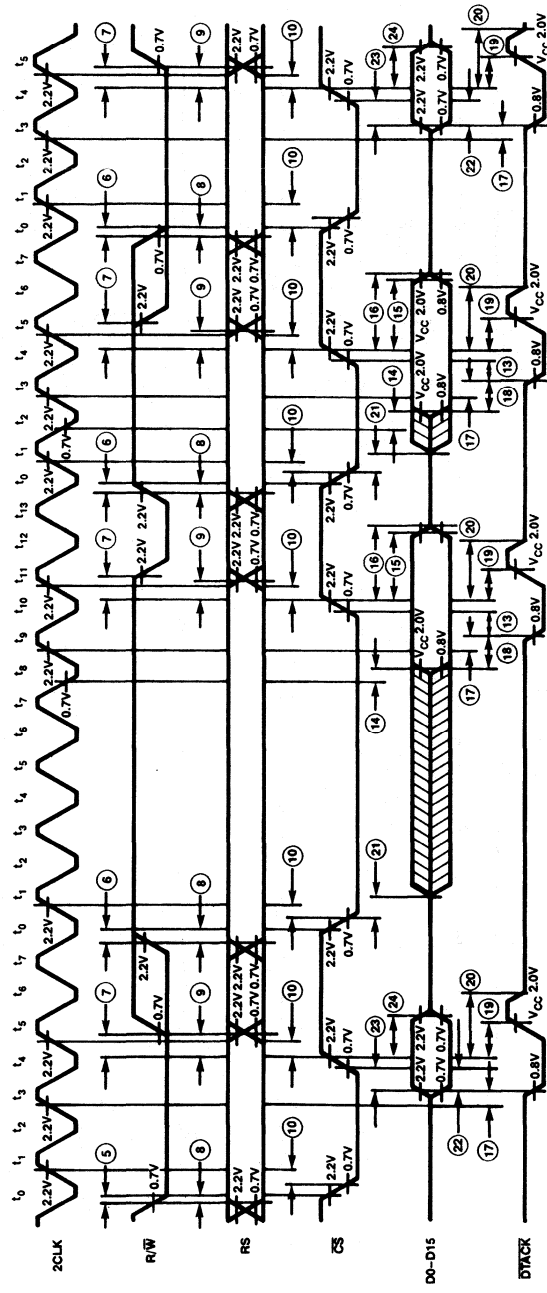

Figure 43. MPU Read/Write Cycle Timing (MPU → ACRTC)



WF134405

NOTE: When the MPU read cycle immediately follows the MPU write cycle execution, DTACK and the read data responses are delayed (by 3 cycles of 2CLK) even though the spec (8) is satisfied.

Figure 43. MPU Read/Write Cycle Timing (MPU → ACRTC) (Continued)

Advanced CRT Controller (ACRTC)

SCC63484

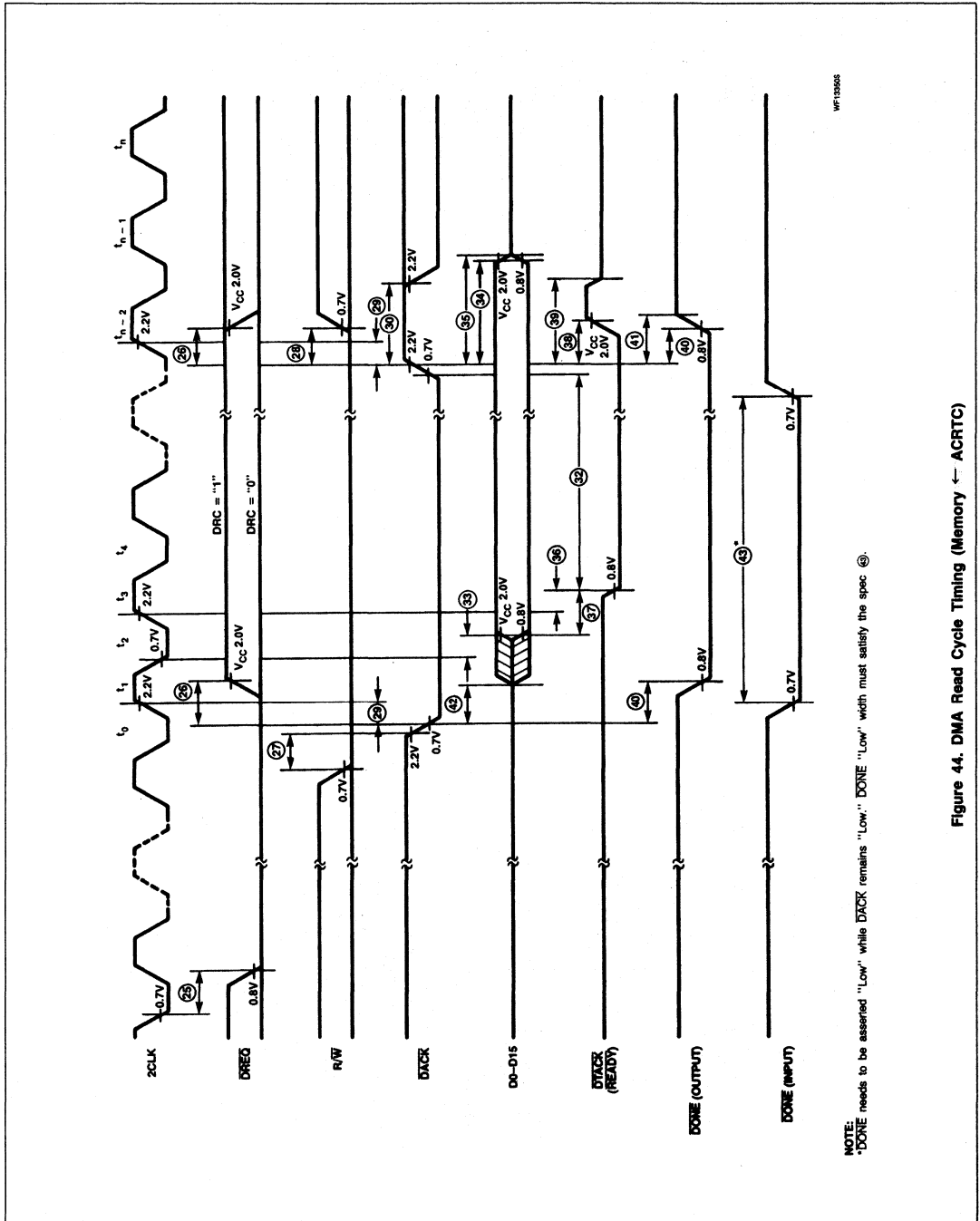

Figure 44. DMA Read Cycle Timing (Memory ← ACRTC)

Advanced CRT Controller (ACRTC)

SCC63484

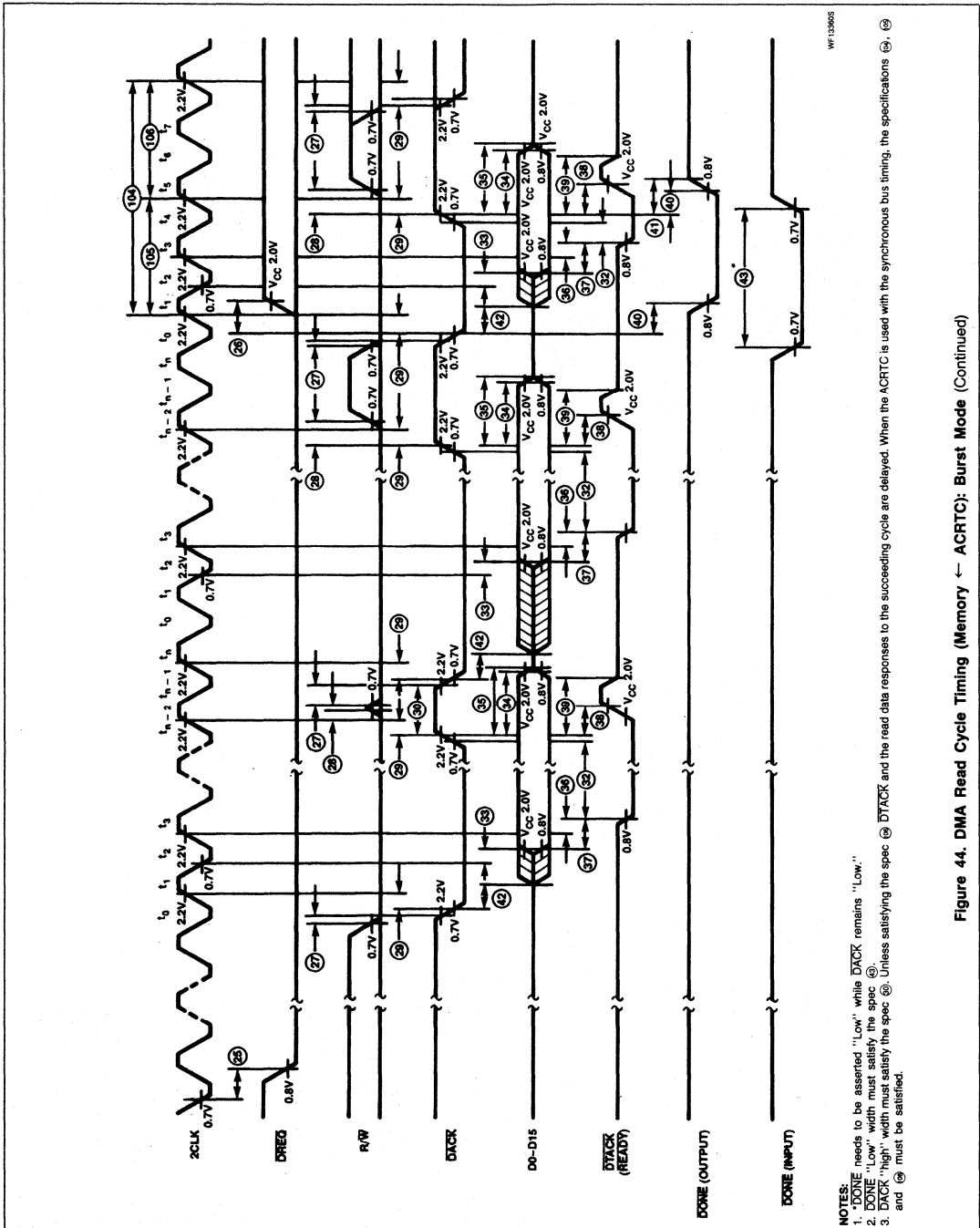

Figure 44. DMA Read Cycle Timing (Memory ← ACRTC); Burst Mode (Continued)

Advanced CRT Controller (ACRTC)

SCC63484

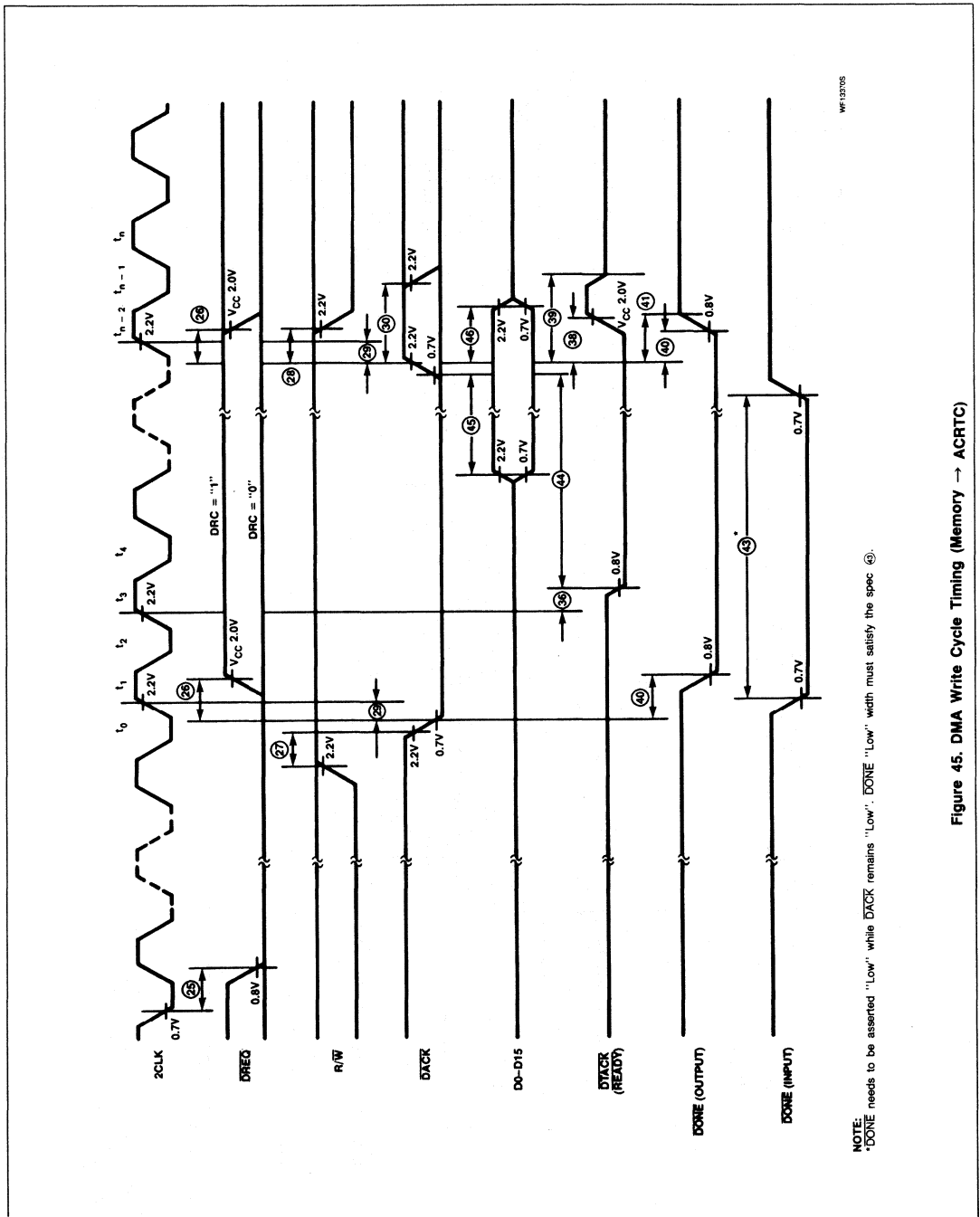

Figure 45. DMA Write Cycle Timing (Memory → ACRTC)



Advanced CRT Controller (ACRTC)

SCC63484

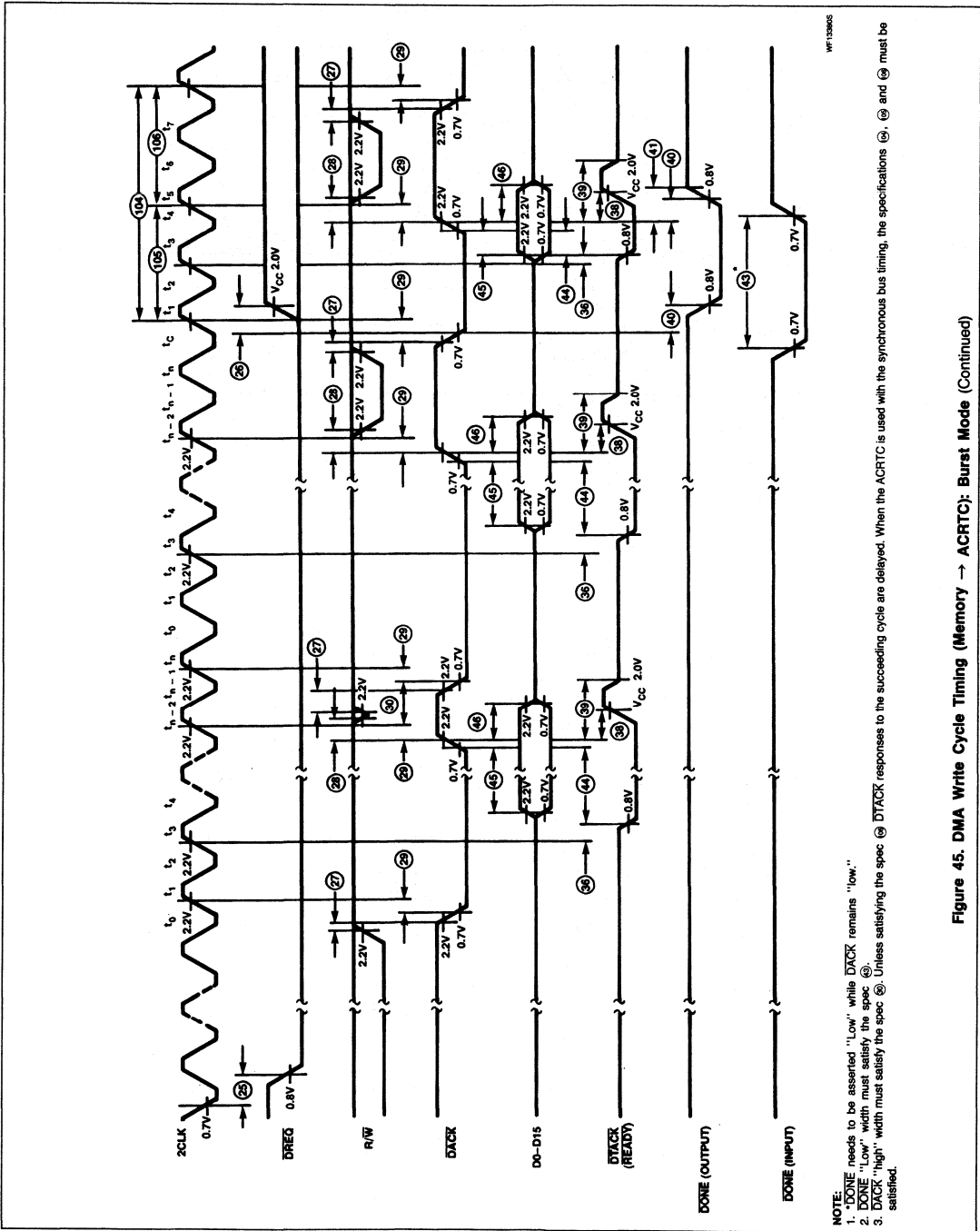
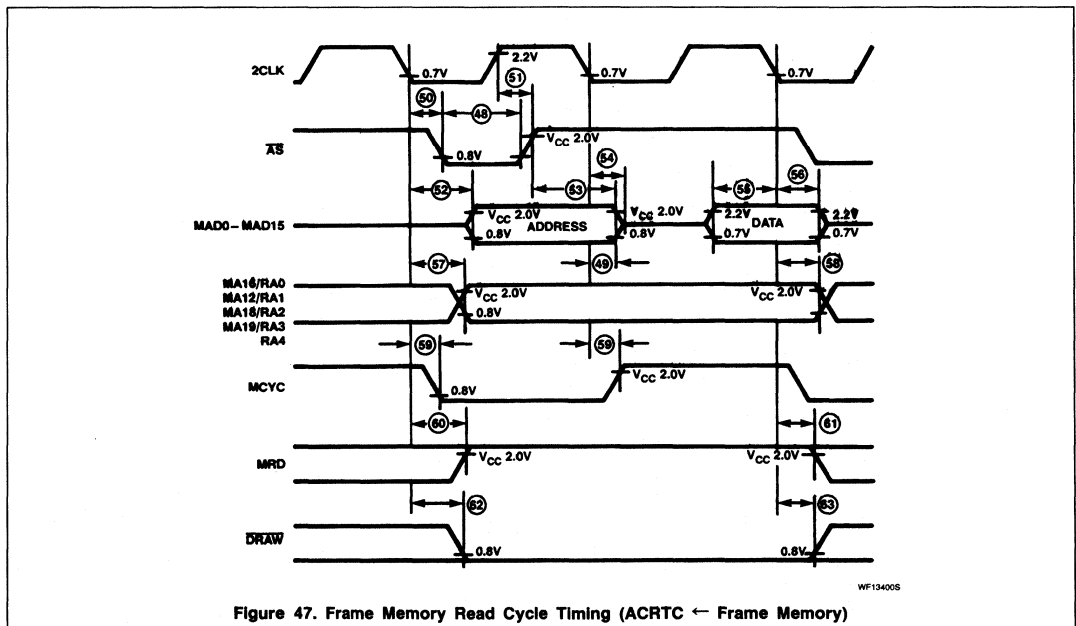
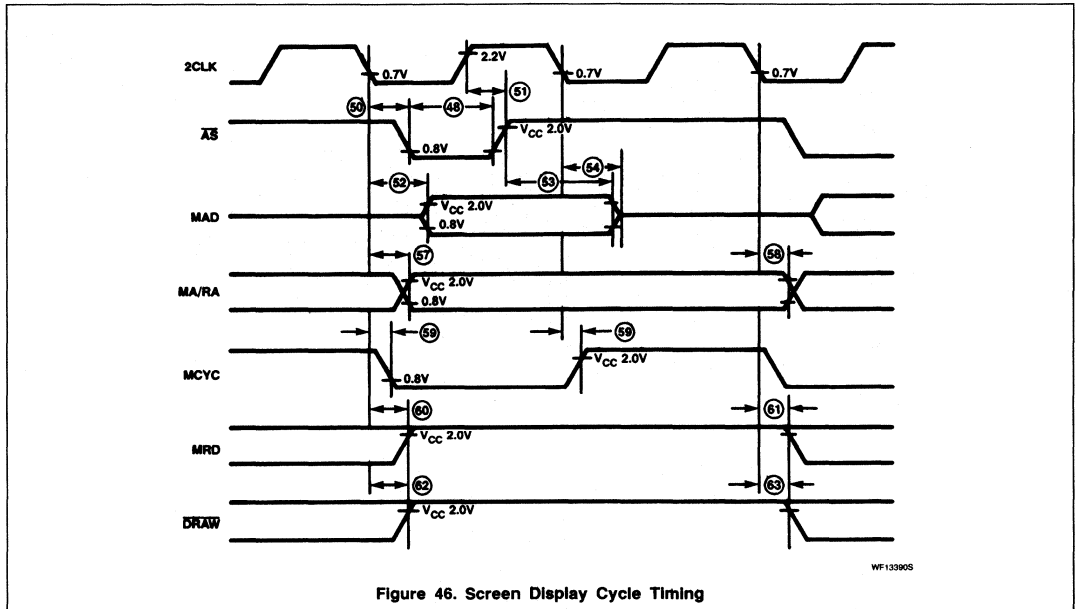

Figure 45. DMA Write Cycle Timing (Memory → ACRTC); Burst Mode (Continued)

Advanced CRT Controller (ACRTC)

SCC63484



Advanced CRT Controller (ACRTC)

SCC63484

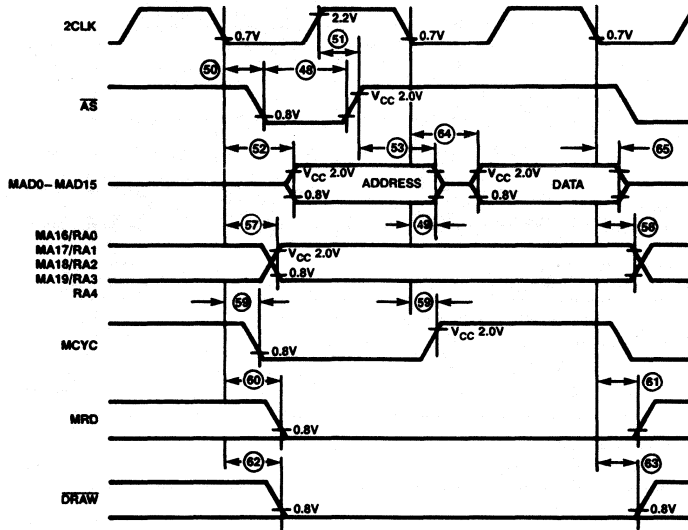

Figure 48. Frame Memory Write Cycle Timing (ACRTC → Frame Memory)

WF134105

2

# Advanced CRT Controller (ACRTC)

# SCC63484

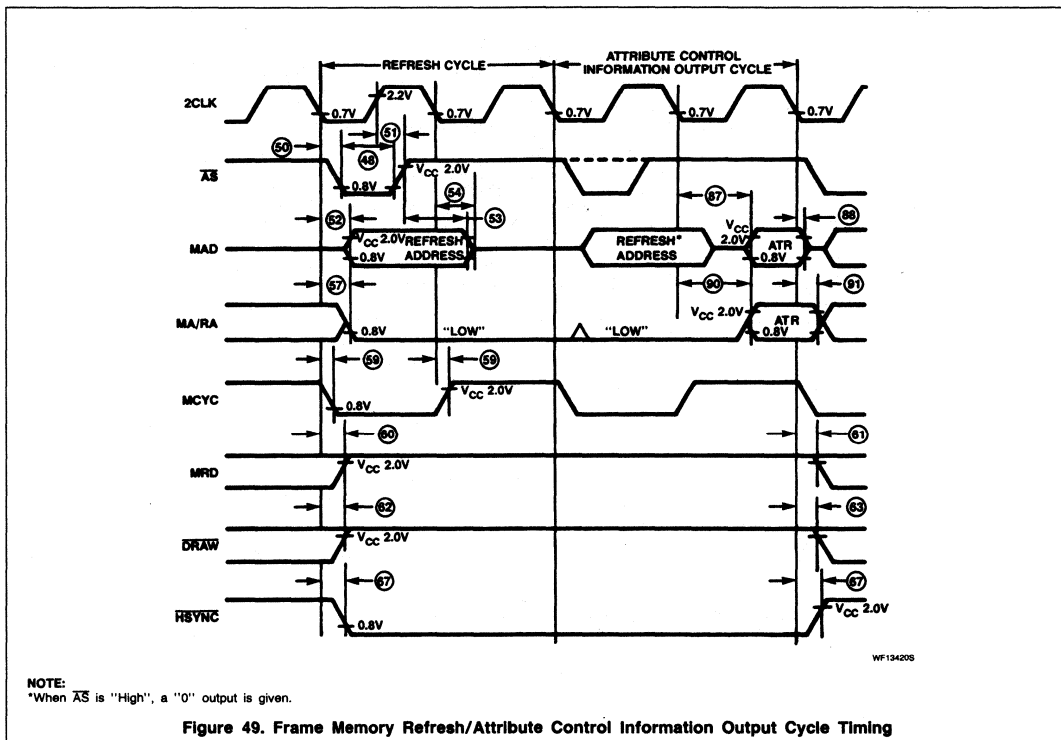

Advanced CRT Controller (ACRTC)

SCC63484

2

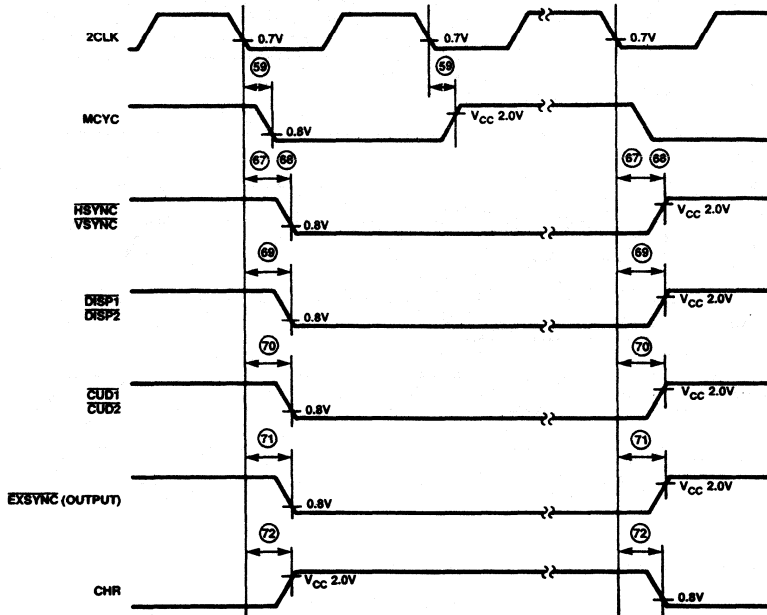

WF134308

Figure 50. Display Control Signal Output Timing

Advanced CRT Controller (ACRTC)

SCC63484

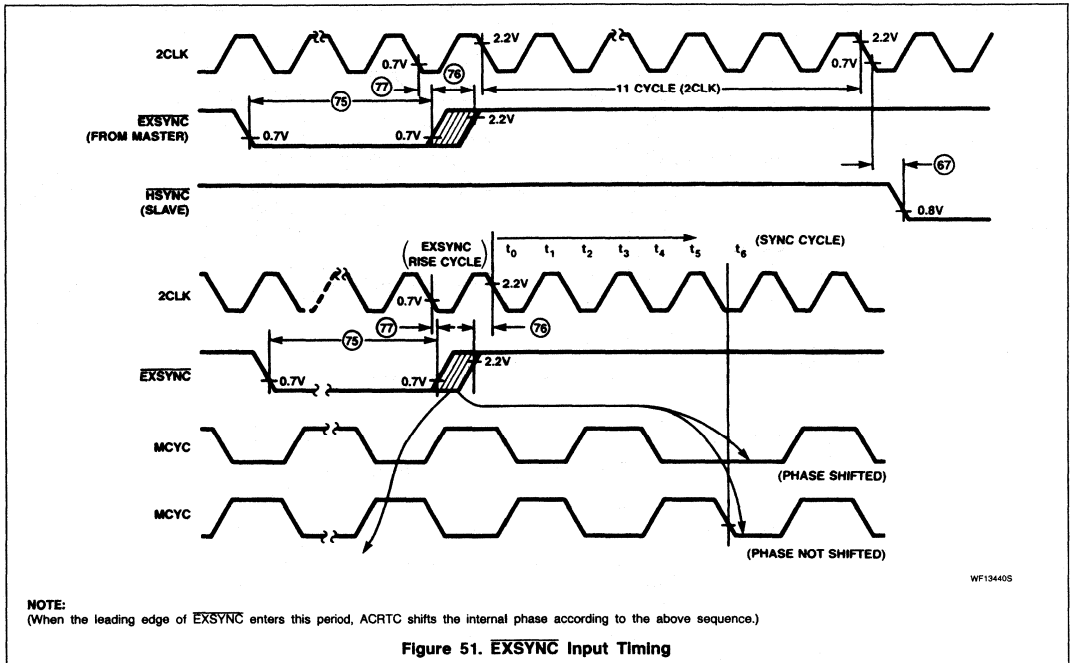

Figure 51. EXSYNC Input Timing

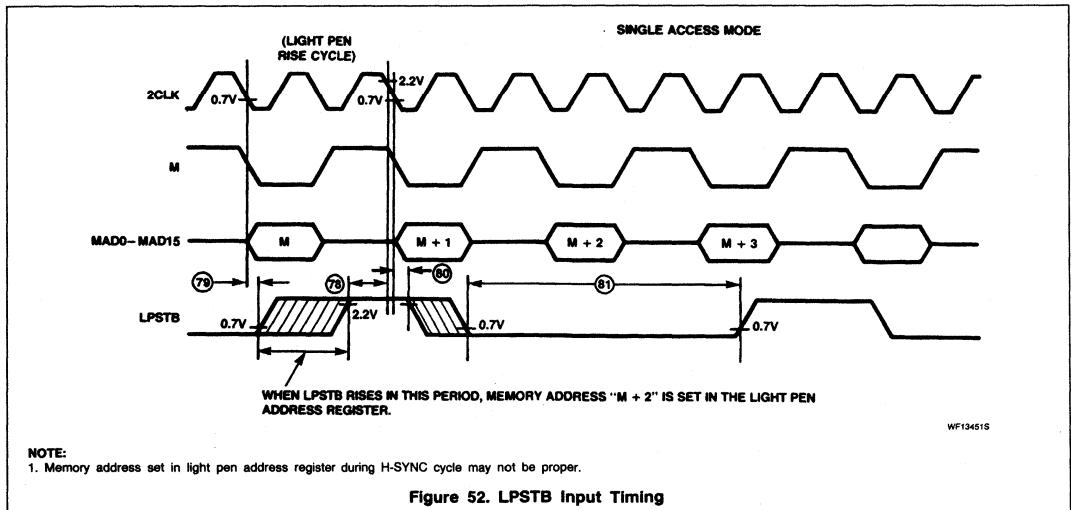
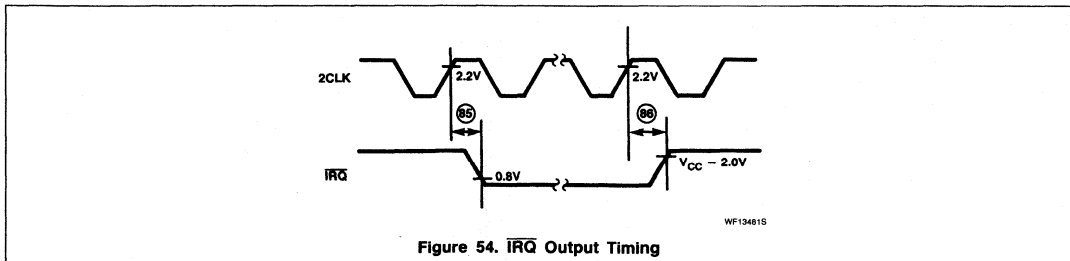
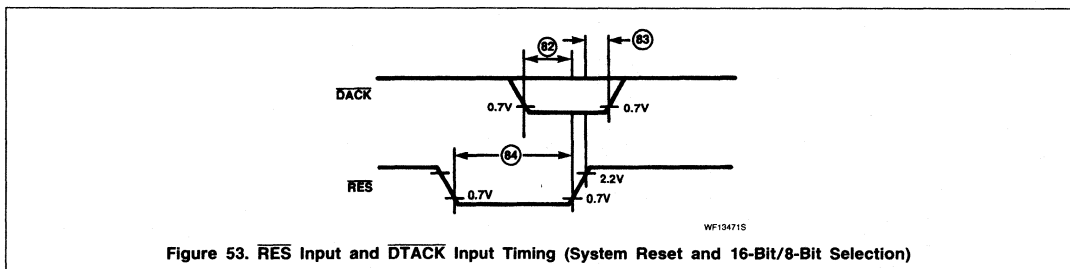
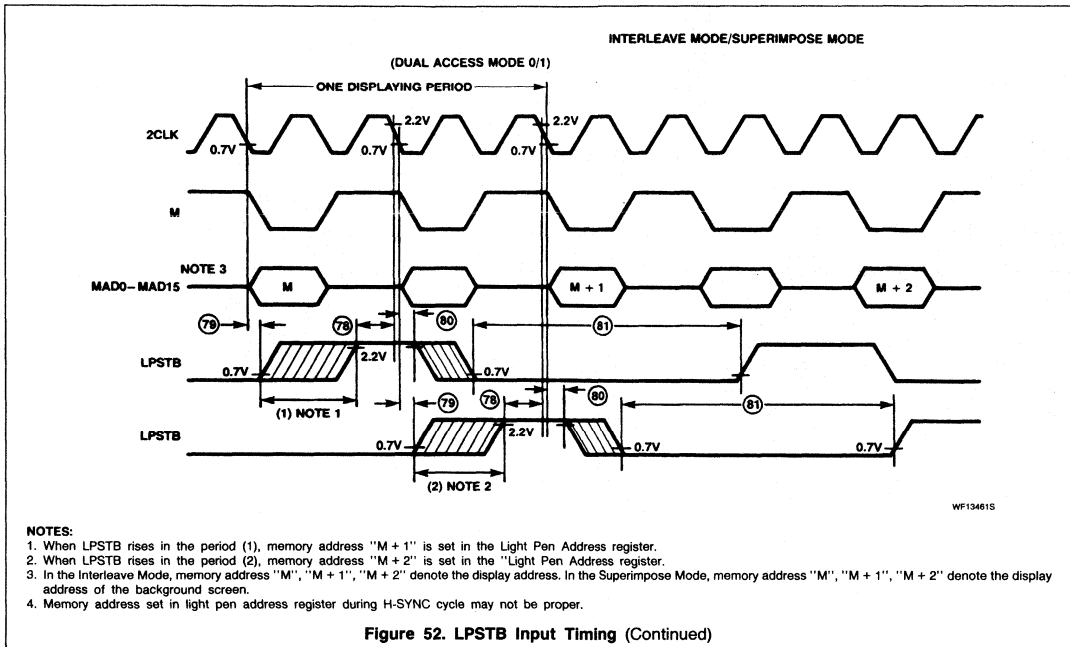

Figure 52. LPSTB Input Timing

# Advanced CRT Controller (ACRTC)

# SCC63484



# SCN68000

## 16-/32-Bit Microprocessor

### Product Specification

#### Microprocessor Products

#### DESCRIPTION

The SCN68000 is the first implementation of the S68000 16/32 bit microprocessor architecture. The SCN68000 has a 16-bit data bus and 24-bit address bus, while the full architecture provides for 32-bit address and data buses. It is completely code-compatible with the SCN68008 8-bit data bus implementation of the S68000 and is downward code-compatible with the SCN68010 virtual extension and the SCN68020 32-bit implementation of the architecture. Any user-mode programs written using the SCN68000 instruction set will run unchanged on the SCN68008, SCN68010, and 68020. This is possible because the user programming model is identical for all four processors and the instruction sets are proper sub-sets of the complete architecture.

The resources available to the SCN68000 user consist of the following:

- 17 32-bit data and address registers
- 16 Mbyte direct addressing range
- 56 powerful instruction types
- Operations on five main data types
- Memory-mapped I/O
- 14 addressing modes

As shown in the programming model (Figure 1), the SCN68000 offers sixteen 32-bit registers and a 32-bit program counter. The first eight registers (D0 - D7) are used as data registers for byte (8-bit), word (16-bit), and long word (32-bit) operations. The second set of seven registers (A0 - A6) and the user stack pointer (USP) may be used as software stack pointers and base address registers. In addition, the registers may be used for word and long word operations. All of the 16 registers may be used as index registers.

#### PIN CONFIGURATIONS

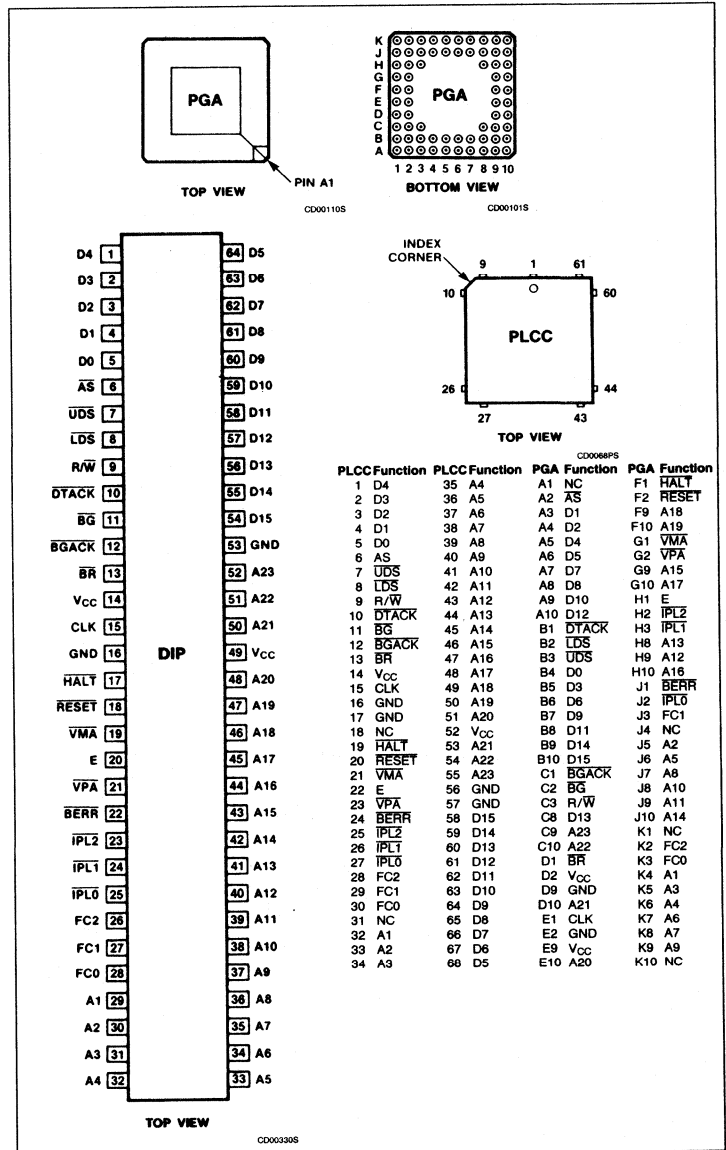



# 16-/32-Bit Microprocessor

# SCN68000

**2**

## ORDERING INFORMATION

PACKAGES	V <sub>CC</sub> = 5V ± 5%, T <sub>A</sub> = 0°C to 70°C		
	8MHz	10MHz	12.5MHz
64-Pin Ceramic DIP	SCN68000C8I64	SCN68000CAI64	SCN68000CBI64
64-Pin Plastic DIP	SCN68000C8N64	SCN68000CAN64	SCN68000CBN64
68-Pin Plastic LCC	SCN68000C8A68	SCN68000CAA68	SCN68000CBA68
68-Pin PGA	SCN68000C8P68	SCN68000CP68	SCN68000CBP68

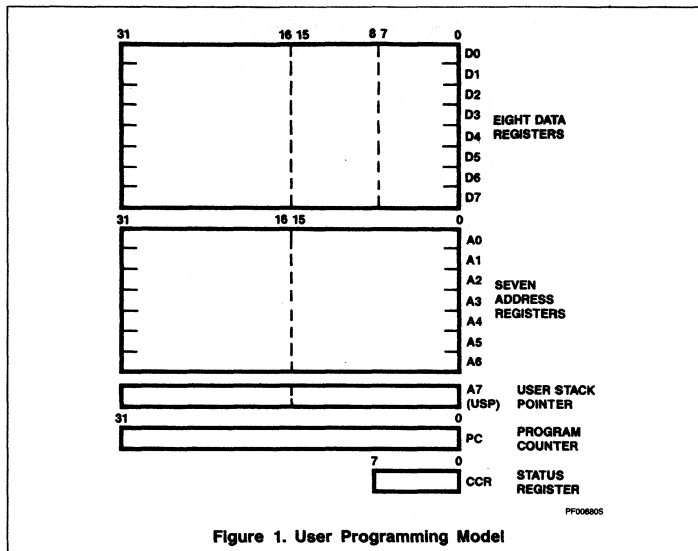

Figure 1. User Programming Model

In supervisor mode, the upper byte of the status register and the supervisor stack pointer (SSP) are also available to the programmer. These registers are shown in Figure 2.

The status register (Figure 3) contains the interrupt mask (eight levels available) as well as the condition codes: extend (X), negative (N), zero (Z), overflow (V), and carry (C). Additional status bits indicate that the processor is in a trace (T) mode and in a supervisor (S) or user state.

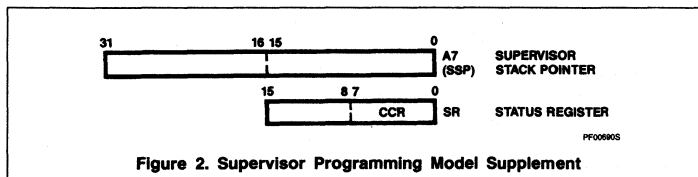

Figure 2. Supervisor Programming Model Supplement

## 16-/32-Bit Microprocessor

SCN68000

### Data Types and Addressing Modes

Five basic data types are supported. These data types are:

- Bits
- BCD digits (4 bits)
- Bytes (8 bits)
- Words (16 bits)
- Long words (32 bits)

In addition, operations on other data types such as memory addresses, status word data, etc., are provided in the instruction set.

The 14 address modes, shown in Table 1, include six basic types:

- Register direct
- Register indirect
- Absolute
- Program counter relative
- Immediate
- Implied

Included in the register indirect addressing modes is the capability to do postincrementing, predecrementing, offsetting, and indexing. The program counter relative mode can also be modified via indexing and offsetting.

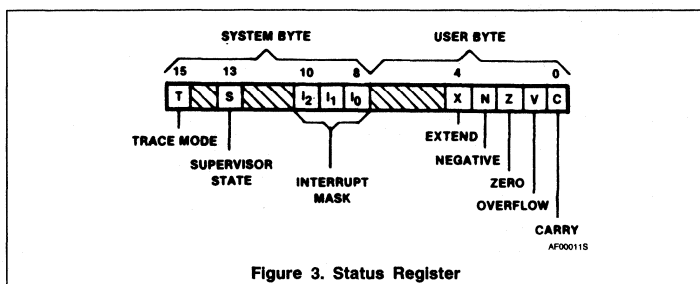

Table 1. Addressing Modes

ADDRESSING MODES	SYNTAX
<b>Register direct addressing</b> Data register direct Address register direct	Dn An
<b>Absolute data addressing</b> Absolute short Absolute long	xxx.W xxx.L
<b>Program counter relative addressing</b> Relative with offset Relative with index and offset	d <sub>16</sub> (PC) d <sub>8</sub> (PC,Xn)
<b>Register indirect addressing</b> Register indirect Postincrement register indirect Predecrement register indirect Register indirect with offset Indexed register indirect with offset	(An) (An) + -(An) d <sub>16</sub> (An) d <sub>8</sub> (An,Xn)
<b>Immediate data addressing</b> Immediate Quick immediate	#xxx #1 - #8
<b>Implied addressing</b> Implied register	SR/USP/SP/PC

**NOTES:**

Dn = Data register  
 An = Address register  
 Xn = Address or data register used as index register  
 SR = Status register  
 PC = Program counter  
 SP = Stack pointer  
 USP = User stack pointer  
 ( ) = Effective Address  
 d<sub>8</sub> = 8-bit offset (displacement)  
 d<sub>16</sub> = 16-bit offset (displacement)  
 #xxx = Immediate data

## 16-/32-Bit Microprocessor

SCN68000

**Instruction Set Overview**

The SCN68000 instruction set is shown in Table 2. Some additional instructions are variations, or subsets, of these and they appear in Table 3. Special emphasis has been given to the instruction set's support of structured high-level languages to facilitate ease of programming. Each instruction, with few exceptions, operates on bytes, words, and long words and most instructions can use any of the 14 addressing modes. Combining instruction types, data types, and addressing modes, over 1000 useful instructions are provided. These instructions include signed and unsigned, multiply and divide, "quick" arithmetic operations, BCD arithmetic, and expanded operations (through traps).

**Table 2. Instruction Set Summary**

MNEMONIC	DESCRIPTION
ABCD ADD AND ASL ASR	Add decimal with extend Add Logical AND Arithmetic shift left Arithmetic shift right
B <sub>CC</sub> BCHG BCLR BRA BSET BSR BTST	Branch conditionally Bit test and change Bit test and clear Branch always Bit test and set Branch to subroutine Bit test
CHK CLR CMP	Check register against bounds Clear operand Compare
DB <sub>CC</sub> DIVS DIVU	Test condition, decrement and branch Signed divide Unsigned divide
EOR EXG EXT	Exclusive OR Exchange registers Sign extend
JMP JSR	Jump Jump to subroutine
LEA LINK LSL LSR	Load effective address Link stack Logical shift left Logical shift right
MOVE MULS MULU	Move source to destination Signed multiply Unsigned multiply
NBCD NEG NOP NOT	Negate decimal with extend Negate No operation One's complement
OR	Logical OR
PEA	Push effective address
RESET ROL ROR ROXL ROXR RTE RTR RTS	Reset external devices Rotate left without extend Rotate right without extend Rotate left with extend Rotate right with extend Return from exception Return and restore Return from subroutine
SBCD S <sub>CC</sub> STOP SUB SWAP	Subtract decimal with extend Set conditional Stop Subtract Swap data register halves
TAS TRAP TRAPV TST	Test and set operand Trap Trap on overflow Test
UNLK	Unlink

2

## 16-/32-Bit Microprocessor

SCN68000

Table 3. Variations of Instruction Types

INSTRUCTION TYPE	VARIATION	DESCRIPTION
ADD	ADD ADDA ADDQ ADDI ADDX	Add Add address Add quick Add immediate Add with extend
AND	AND ANDI ANDI to CCR ANDI to SR	Logical AND AND immediate AND immediate to condition codes AND immediate to status register
CMP	CMP CMPA CMPM CMPI	Compare Compare address Compare memory Compare immediate
EOR	EOR EORI EORI to CCR EORI to SR	Exclusive OR Exclusive OR immediate Exclusive OR immediate to condition codes Exclusive OR immediate to status register
MOVE	MOVE MOVEA MOVEM MOVEP MOVEQ MOVE from SR MOVE to SR MOVE to CCR MOVE USP	Move source to destination Move address Move multiple registers Move peripheral data Move quick Move from status register Move to status register Move to condition codes Move user stack pointer
NEG	NEG NEGX	Negate Negate with extend
OR	OR ORI ORI to CCR ORI to SR	Logical OR OR immediate OR immediate to condition codes OR immediate to status register
SUB	SUB SUBA SUBI SUBQ SUBX	Subtract Subtract address Subtract immediate Subtract quick Subtract with extend

## 16-/32-Bit Microprocessor

SCN68000

**DATA ORGANIZATION AND ADDRESSING CAPABILITIES**

This section contains a description of the registers and the data organization of the SCN68000.

**Operand Size**

Operand sizes are defined as follows: a byte equals 8 bits, a word equals 16 bits, and a long word equals 32 bits. The operand size for each instruction is either explicitly encoded in the instruction or implicitly defined by the instruction operation. Implicit instructions support some subset of all three sizes.

**Data Organization in Registers**

The eight data registers support data operands of 1, 8, 16, or 32 bits. The seven address registers together with the stack pointers support address operands of 32 bits.

**Data Registers**

Each data register is 32 bits wide. Byte operands occupy the low-order 8 bits, word operands the low-order 16 bits, and long-word operands the entire 32 bits. The least significant bit is addressed as bit zero; the most significant bit is addressed as bit 31.

When a data register is used as either a source or destination operand, only the appropriate low-order portion is changed; the remaining high-order portion is neither used nor changed.

**Address Registers**

Each address register and the stack pointer is 32 bits wide and holds a full 32-bit address. Address registers do not support the sized operands. Therefore, when an address register is used as a source operand, either the low-order word or the entire long-word operand is used depending on the operation size. When an address register is used as the destination operand, the entire register is affected regardless of the operation size. If the operation size is word, any other operands are sign extended to 32 bits before the operation is performed.

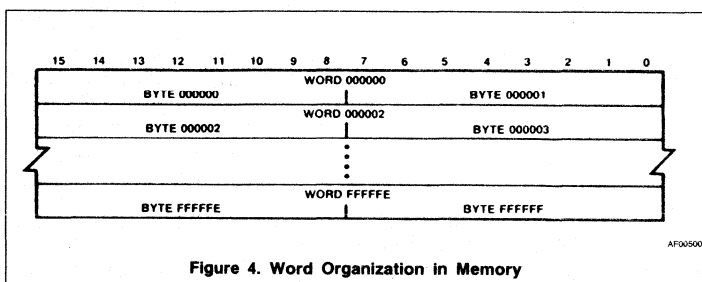
**Data Organization in Memory**

Bytes are individually addressable with the high-order byte having an even address the same as the word, as shown in Figure 4. The low-order byte has an odd address that is one count higher than the word address. Instructions and multibyte data are accessed only on word (even byte) boundaries. If a long word datum is located at address  $n$  ( $n$  even), then the second word of that datum is located at address  $n + 2$ .

The data types supported by the SCN68000 are: bit data, integer data of 8, 16, or 32 bits, 32-bit addresses and binary-coded decimal data. Each of these data types is put in memory, as shown in Figure 5. The numbers indicate the order in which the data would be accessed from the processor.

**Addressing**

Instructions for the SCN68000 contain two kinds of information: the type of function to be performed and the location of the operand(s) on which to perform that function. The methods used to locate (address) the operand(s) are explained in the following paragraphs.

Instructions specify an operand location in one of three ways:

**Register specification** – the number of the register is given in the register field of their instruction.

**Effective address** – use of the different effective addressing modes.

**Implicit reference** – the definition of certain instructions implies the use of specific registers.

**Instruction Format**

Instructions are from one to five words in length as shown in Figure 6. The length of the instruction and the operation to be performed is specified by the first word of the instruction which is called the operation word. The remaining words further specify the operands. These words are either immediate operands or extensions to the effective address mode specified in the operation word.

**Program/Data References**

The SCN68000 separates memory references into two classes: program references and data references. Program references, as the name implies, are references to that section of memory that contains the program being executed. Data references refer to that section of memory that contains data. Operand reads are from the data space except in the case of the program counter relative addressing mode. All operand writes are to the data space.

**Register Specification**

The register field within an instruction specifies the register to be used. Other fields within the instruction specify whether the register selected is an address or data register and how the register is to be used.

16-/32-Bit Microprocessor

SCN68000

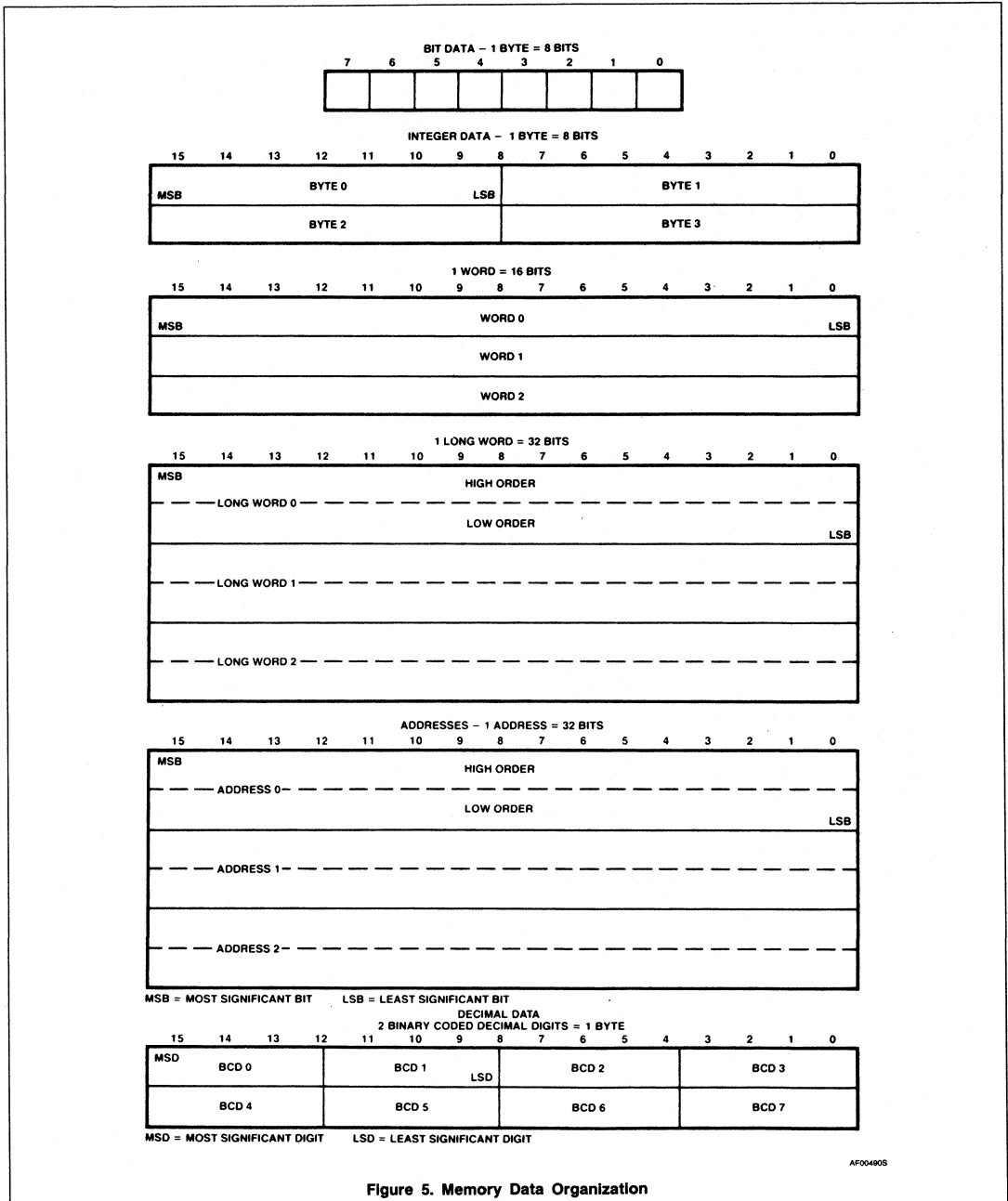

Figure 5. Memory Data Organization

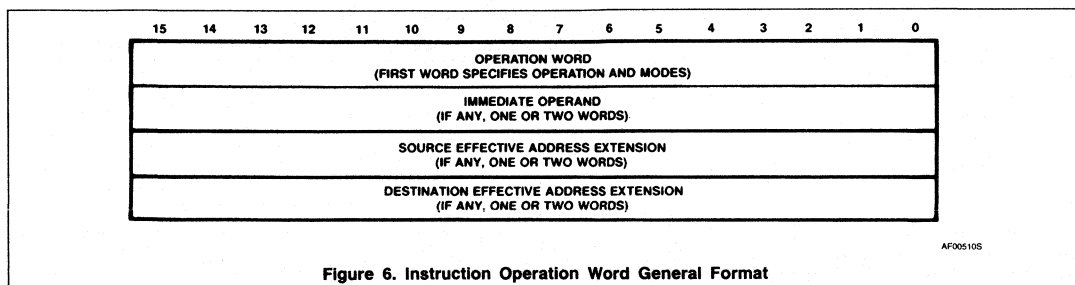

Figure 6. Instruction Operation Word General Format

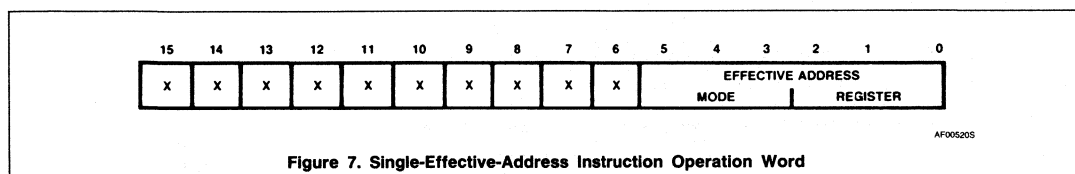

Figure 7. Single-Effective-Address Instruction Operation Word

### Effective Address

Most instructions specify the location of an operand by using the effective address field in the operation word. For example, Figure 7 shows the general format of the single-effective-address instruction operation word. The effective address is composed of two 3-bit fields: the mode field and the register field. The value in the mode field selects the different address modes. The register field contains the number of a register.

The effective address field may require additional information to fully specify the operand. This additional information, called the effective address extension, is contained in the following word or words and is considered part of the instruction, as shown in Figure 6. The effective address modes are grouped into three categories: register direct, memory addressing, and special.

#### Register Direct Modes

These effective addressing modes specify that the operand is in one of 16 multifunction registers.

**Data Register Direct** — The operand is in the data register specified by the effective address register field.

**Address Register Direct** — The operand is in the address register specified by the effective address register field.

#### Memory Address Modes

These effective addressing modes specify that the operand is in memory and provide the specific address of the operand.

**Address Register Indirect** — The address of the operand is in the address register specified by the register field. The reference is classified as a data reference with the

exception of the jump and jump-to-subroutine instructions.

**Address Register Indirect with Postincrement** — The address of the operand is in the address register specified by the register field. After the operand address is used, it is incremented by one, two, or four depending on whether the size of the operand is byte, word, or long word. If the address register is the stack pointer and the operand size is byte, the address is incremented by two rather than one to keep the stack pointer on a word boundary. The reference is classified as a data reference.

**Address Register Indirect with Predecrement** — The address of the operand is in the address register specified by the register field. Before the operand address is used, it is decremented by one, two, or four depending upon whether the operand size is byte, word, or long word. If the address register is the stack pointer and the operand size is byte, the address is decremented by two rather than one to keep the stack pointer on a word boundary. The reference is classified as a data reference.

**Address Register Indirect with Displacement** — This addressing mode requires one word of extension. The address of the operand is the sum of the address in the address register and the sign-extended 16-bit displacement integer in the extension word. The reference is classified as a data reference with the exception of the jump and jump-to-subroutine instructions.

**Address Register Indirect with Index** — This addressing mode requires one word of extension. The address of the operand is the sum of the address in the address register,

the sign-extended displacement integer in the low order eight bits of the extension word, and the contents of the index register. The reference is classified as a data reference with the exception of the jump and jump-to-subroutine instructions.

#### Special Address Modes

The special address modes use the effective address register field to specify the special addressing mode instead of a register number.

**Absolute Short Address** — This addressing mode requires one word of extension. The address of the operand is the extension word. The 16-bit address is sign extended before it is used. The reference is classified as a data reference with the exception of the jump and jump-to-subroutine instructions.

**Absolute Long Address** — This addressing mode requires two words of extension. The address of the operand is developed by the concatenation of the extension words. The high order part of the address is the first extension word; the low order part of the address is the second extension word. The reference is classified as a data reference with the exception of the jump and jump-to-subroutine instructions.

**Program Counter with Displacement** — This addressing mode requires one word of extension. The address of the operand is the sum of the address in the program counter and the sign-extended 16-bit displacement integer in the word. The value in the program counter is the address of the extension word. The reference is classified as a program reference.

## 16-/32-Bit Microprocessor

SCN68000

**Program Counter with Index** — This addressing mode requires one word of extension. The address is the sum of the address in the program counter, the sign-extended displacement integer in the lower eight bits of the extension word, and the contents of the index register. The value in the program counter is the address of the extension word. This reference is classified as a program reference.

**Immediate Data** — This addressing mode requires either one or two words of extension depending on the size of the operation.

Byte operation — operand is low-order byte of extension word.

Word operation — operand is extension word.

Long-word operation — operand is in the two extension words, high-order 16 bits are in the first extension word, low-order 16 bits are in the second extension word.

**Implicit Reference** — Some instructions make implicit reference to the program counter (PC), the system stack pointer (SP), the supervisor stack pointer (SSP), the user stack pointer (USP), or the status register (SR). A selected set of instructions may reference the status register by means of the effective address field. These are:

ANDI to CCR	ORI to SR
ANDI to SR	MOVE to CCR
EORI to CCR	MOVE to SR
EORI to SR	MOVE from SR
ORI to CCR	

### Effective Address Encoding Summary

Table 4 is a summary of the effective addressing modes discussed in the previous paragraphs.

### System Stack

The system stack is used implicitly by many instructions; user stacks and queues may be created and maintained through the addressing modes. Address register seven (A7) is the system stack pointer (SP). The system stack pointer is either the supervisor stack pointer (SSP) or the user stack pointer (USP), depending on the state of the S bit in the status register. If the S bit indicates supervisor state, SSP is the active system stack pointer and the USP cannot be referenced as an address register. If the S bit indicates user state, the USP is the active system stack pointer and the SSP cannot be referenced. Each system stack fills from high memory to low memory.

### INSTRUCTION SET SUMMARY

This section contains an overview of the form and structure of the SCN68000 instruction set. The instructions form a set of tools that

**Table 4. Effective Address Encoding Summary**

ADDRESSING MODE	MODE	REGISTER
Data register direct	000	Register number
Address register direct	001	Register number
Address register indirect	010	Register number
Address register indirect with postincrement	011	Register number
Address register indirect with predecrement	100	Register number
Address register indirect with displacement	101	Register number
Address register indirect with index	110	Register number
Absolute short	111	000
Absolute long	111	001
Program counter with displacement	111	010
Program counter with index	111	011
Immediate	111	100

**Table 5. Data Movement Operations**

INSTRUCTION	OPERAND SIZE	OPERATION
EXG	32	Rx ↔ Ry
LEA	32	EA → An
LINK	-	AN → -(SP) SP → An SP + displacement → SP
MOVE	8, 16, 32	s → (EA)d
MOVEM	16, 32	(EA) → An, Dn An, Dn → EA
MOVEP	16, 32	(EA) → Dn Dn → (EA)
MOVEQ	8	#xxx → Dn
PEA	32	EA → -(SP)
SWAP	32	Dn[31:16] ↔ Dn[15:0]
UNLK	-	An → SP (SP) + → An

**NOTES:**

s = source  
d = destination

[ ] = bit number  
- ( ) = indirect with predecrement

( ) + = indirect with postdecrement  
# = immediate data

include all the machine functions to perform the following operations:

Data movement	Bit manipulation
Integer arithmetic	Binary coded decimal
Logical	Program control
Shift and rotate	System control

The complete range of instruction capabilities combined with the flexible addressing modes described previously provide a very flexible base for program development.

### Data Movement Operations

The basic method of data acquisition (transfer and storage) is provided by the move (MOVE) instruction. The move instruction and the effective addressing modes allow both address and data manipulation. Data move

instructions allow byte, word, and long-word operands to be transferred from memory to memory, memory to register, register to memory, and register to register. Address move instructions allow word and long-word operand transfers and ensure that only legal address manipulations are executed. In addition to the general move instruction there are several special data movement instructions: move multiple registers (MOVEM), move peripheral data (MOVEP), exchange registers (EXG), load effective address (LEA), push effective address (PEA), link stack (LINK), unlink stack (UNLK), and move quick (MOVEQ). Table 5 is a summary of the data movement operations.



## 16-/32-Bit Microprocessor

SCN68000

**Integer Arithmetic Operations**

The arithmetic operations include the four basic operations of add (ADD), subtract (SUB), multiply (MUL), and divide (DIV), as well as arithmetic compare (CMP), clear (CLR), and negate (NEG). The add and subtract instructions are available for both address and data operations, with data operations accepting all operand sizes. Address operations are limited to legal address size operands (16 or 32 bits). Data, address, and memory compare operations are also available. The clear and negate instructions may be used on all sizes of data operands.

The multiply and divide operations are available for signed and unsigned operands using word multiply to produce a long-word product, and a long-word dividend with word divisor to produce a word quotient with a word remainder.

Multiprecision and mixed size arithmetic can be accomplished using a set of extended instructions. These instructions are: add extended (ADDX), subtract extended (SUBX), sign extend (EXT), and negate binary with extend (NEGX).

A test operand (TST) instruction that will set the condition codes as a result of a compare of the operand with zero is also available. Test and set (TAS) is a synchronization instruction useful in multiprocessor systems. Table 6 is a summary of the integer arithmetic operations.

**Table 6. Integer Arithmetic Operations**

INSTRUCTION	OPERAND SIZE	OPERATION
ADD	8, 16, 32	$D_n + (EA) \rightarrow D_n$ $(EA) + D_n \rightarrow (EA)$ $(EA) + \#xxx \rightarrow (EA)$
	16, 32	$A_n + (EA) \rightarrow A_n$
ADDX	8, 16, 32	$D_x + D_y + X \rightarrow D_x$
	16, 32	$-(A_x) + -(A_y) + X \rightarrow (A_x)$
CLR	8, 16, 32	$0 \rightarrow EA$
CMP	8, 16, 32	$D_n - (EA)$ $(EA) - \#xxx$ $(A_x) + -(A_y)$
	16, 32	$A_n - (EA)$
DIVS	32 ÷ 16	$D_n \div (EA) \rightarrow D_n$
DIVU	32 ÷ 16	$D_n \div (EA) \rightarrow D_n$
EXT	8 → 16	$(D_n)_8 \rightarrow D_{n16}$
	16 → 32	$(D_n)_{16} \rightarrow D_{n32}$
MULS	16 × 16 → 32	$D_n \times (EA) \rightarrow D_n$
MULU	16 × 16 → 32	$D_n \times (EA) \rightarrow D_n$
NEG	8, 16, 32	$0 - (EA) \rightarrow (EA)$
NEGX	8, 16, 32	$0 - (EA) - X \rightarrow (EA)$
SUB	8, 16, 32	$D_n - (EA) \rightarrow D_n$ $(EA) - D_n \rightarrow (EA)$ $(EA) - \#xxx \rightarrow (EA)$
	16, 32	$A_n - (EA) \rightarrow A_n$
SUBX	8, 16, 32	$D_x - D_y - X \rightarrow D_x$ $-(A_x) - -(A_y) - X \rightarrow (A_x)$
TAS	8	$(EA) - 0, 1 \rightarrow EA[7]$
TST	8, 16, 32	$(EA) - 0$

**NOTES:**

[ ] = bit number

# = immediate data

-( ) = indirect with predecrement

( )+ = indirect with postdecrement

**Logical Operations**

Logical operation instructions AND, OR, EOR, and NOT are available for all sizes of integer data operands. A similar set of immediate instructions (ANDI, ORI, and EORI) provide these logical operations with all sizes of immediate data. Table 7 is a summary of the logical operations.

**Table 7. Logical Operations**

INSTRUCTION	OPERAND SIZE	OPERATION
AND	8, 16, 32	$D_n \wedge (EA) \rightarrow D_n$
		$(EA) \wedge D_n \rightarrow (EA)$
		$(EA) \wedge \#xxx \rightarrow (EA)$
OR	8, 16, 32	$D_n \vee (EA) \rightarrow D_n$
		$(EA) \vee D_n \rightarrow (EA)$
		$(EA) \vee \#xxx \rightarrow (EA)$
EOR	8, 16, 32	$(EA) \oplus D_y \rightarrow (EA)$
		$(EA) \oplus \#xxx \rightarrow (EA)$
NOT	8, 16, 32	$\sim(EA) \rightarrow (EA)$

**NOTES:**

# = immediate data

~ = invert

^ = logical AND

∨ = logical OR

⊕ = logical exclusive OR

## 16-/32-Bit Microprocessor

SCN68000

**Shift and Rotate Operations**

Shift operations in both directions are provided by the arithmetic instructions ASR and ASL and logical shift instructions LSR and LSL. The rotate instructions (with and without extend) available are ROXR, ROXL, ROR, and ROL. All shift and rotate operations can be performed in either registers or memory. Register shifts and rotates support all operand sizes and allow a shift count specified in a data register.

Memory shifts and rotates are for word operands only and allow only single-bit shifts or rotates.

Table 8 is a summary of the shift and rotate operations.

**Table 8. Shift and Rotate Operations**

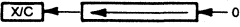
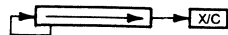
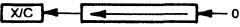
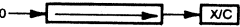
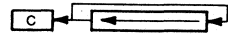
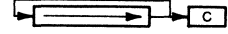
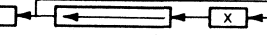
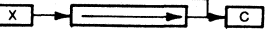
INSTRUCTION	OPERAND SIZE	OPERATION
ASL	8, 16, 32	
ASR	8, 16, 32	
LSL	8, 16, 32	
LSR	8, 16, 32	
ROL	8, 16, 32	
ROR	8, 16, 32	
ROXL	8, 16, 32	
ROXR	8, 16, 32	

**Bit Manipulation Operations**

Bit manipulation operations are accomplished using the following instructions: bit test (BTST), bit test and set (BSET), bit test and clear (BCLR), and bit test and change (BCHG). Table 9 is a summary of the bit manipulation operations. (Z is bit 2 of the status register.)

**Table 9. Bit Manipulation Operations**

INSTRUCTION	OPERAND SIZE	OPERATION
BTST	8, 32	$\sim$ bit of (EA) $\rightarrow$ Z
BSET	8, 32	$\sim$ bit of (EA) $\rightarrow$ Z 1 $\rightarrow$ bit of EA
BCLR	8, 32	$\sim$ bit of (EA) $\rightarrow$ Z 0 $\rightarrow$ bit of EA
BCHG	8, 32	$\sim$ bit of (EA) $\rightarrow$ Z $\sim$ bit of (EA) $\rightarrow$ bit of EA

NOTE:

 $\sim$  = invert**Binary Coded Decimal Operations**

Multiprecision arithmetic operations on binary coded decimal numbers are accomplished using the following instructions: add decimal with extend (ABCD), subtract decimal with extend (SBCD), and negate decimal with extend (NBCD). Table 10 is a summary of the binary coded decimal operations.

**Table 10. Binary Coded Decimal Operations**

INSTRUCTION	OPERAND SIZE	OPERATION
ABCD	8	$Dx_{10} + Dy_{10} + X \rightarrow Dx$ $-(Ax)_{10} + -(Ay)_{10} + X \rightarrow (Ax)$
SBCD	8	$Dx_{10} - Dy_{10} - X \rightarrow Dx$ $-(Ax)_{10} - -(Ay)_{10} - X \rightarrow (Ax)$
NBCD	8	$0 - (EA)_{10} - X \rightarrow (EA)$

NOTE:

-( ) = indirect with predecrement.

## 16-/32-Bit Microprocessor

SCN68000

**Program Control Operations**

Program control operations are accomplished using a series of conditional and unconditional branch instructions and return instructions. These instructions are summarized in Table 11.

The conditional instructions provide setting and branching for the following conditions:

CC – carry clear	LS – low or same
CS – carry set	LT – less than
EQ – equal	MI – minus
F – never true	NE – not equal
GE – greater or equal	PL – plus
GT – greater than	T – always true
HI – high	VC – no overflow
LE – less or equal	VS – overflow

**Table 11. Program Control Operations**

INSTRUCTION	OPERATION
<b>Conditional</b>	
BCC	Branch conditionally (14 conditions) 8- and 16-bit displacement
DBCC	Test condition, decrement, and branch 16-bit displacement
SCC	Set byte conditionally (16 conditions)
<b>Unconditional</b>	
BRA	Branch always 8- and 16-bit displacement
BSR	Branch to subroutine 8- and 16-bit displacement
JMP	Jump
JSR	Jump to subroutine
<b>Returns</b>	
RTR	Return and restore condition codes
RTS	Return from subroutine

**System Control Operations**

System control operations are accomplished by using privileged instructions, trap generating instructions, and instructions that use or modify the status register. These instructions are summarized in Table 12.

**Table 12. System Control Operations**

INSTRUCTION	OPERATION
<b>Privileged</b>	
ANDI to SR	Logical AND to status register
EORI to SR	Logical EOR to status register
MOVE EA to SR	Load new status register
MOVE USP	Move user stack pointer
ORI to SR	Logical OR to status register
RESET	Reset external devices
RTE	Return from exception
STOP	Stop program execution
<b>Trap generating</b>	
CHK	Check data register against upper bounds
TRAP	Trap
TRAPV	Trap on overflow
<b>Status register</b>	
ANDI to CCR	Logical AND to condition codes
EORI to CCR	Logical EOR to condition codes
MOVE EA to CCR	Load new condition codes
MOVE SR to EA	Store status register
ORI to CCR	Logical OR to condition codes

# 16-/32-Bit Microprocessor

SCN68000

## SIGNAL AND BUS OPERATION DESCRIPTION

This section contains a brief description of the input and output signals. A discussion of bus operation during the various machine cycles and operations is also given.

**NOTE:**

The terms **assertion** and **negation** will be used extensively. This is done to avoid confusion when dealing with a mixture of "active-low" and "active-high" signals. The term **assert** or **assertion** is used to indicate that a signal is active or true, independent of whether that level is represented by a high or low voltage. The term **negate** or **negation** is used to indicate that a signal is inactive or false.

### Signal Description

The input and output signals can be functionally organized into the groups shown in Figure 8. The following paragraphs provide a brief description of the signals and a reference (if applicable) to other paragraphs that contain more detail about the function being performed.

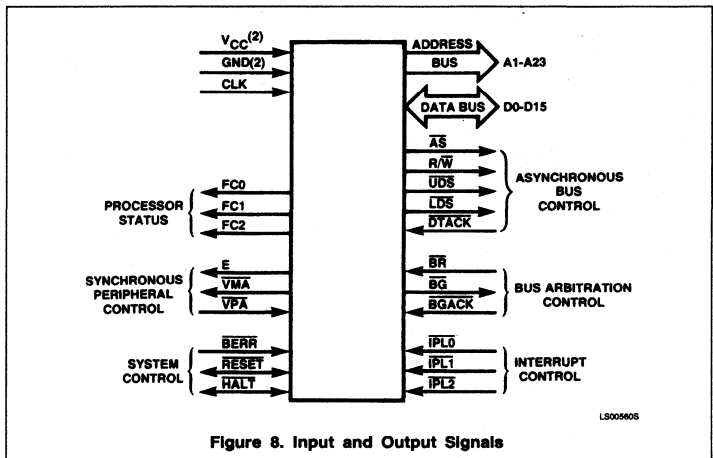

Figure 8. Input and Output Signals

### Address Bus (A1 through A23)

This 23-bit, unidirectional, 3-State bus is capable of addressing 8 megawords of data. It provides the address for bus operation during all cycles except interrupt cycles. During interrupt cycles, address lines A1, A2, and A3 provide information about what level interrupt is being serviced while address lines A4 through A23 are all set to a logic high.

### Data Bus (D0 through D15)

This 16-bit bidirectional, 3-State bus is the general purpose data path. It can transfer and accept data in either word or byte length. During an interrupt acknowledge cycle, the external device supplies the vector number on data lines D0-D7.

### Asynchronous Bus Control

Asynchronous data transfers are handled using the following control signals: address strobe, read/write, upper and lower data strobes, and data transfer acknowledge. These signals are explained in the following paragraphs.

**Address Strobe (AS)** — This signal indicates that there is a valid address on the address bus.

**Read/Write (R/W)** — This signal defines the data bus transfer as a read or write cycle. The R/W signal also works in conjunction with the data strobes as explained in the following paragraph.

**Upper and Lower Data Strobe (UDS, LDS)** — These signals control the flow of data on the data bus, as shown in Table 13. When the R/W line is high, the processor will read from the data bus as indicated. When the R/W line is low, the processor will write to the data bus as shown.

**Data Transfer Acknowledge (DTACK)** — This input indicates that the data transfer is

Table 13. Data Strobe Control of Data Bus

UDS	LDS	R/W	D8 - D15	D0 - D7
High	High	—	No valid data	No valid data
Low	Low	High	Valid data bits 8 - 15	Valid data bits 0 - 7
High	Low	High	No valid data	Valid data bits 0 - 7
Low	High	High	Valid data bits 8 - 15	No valid data
Low	Low	Low	Valid data bits 8 - 15	Valid data bits 0 - 7
High	Low	Low	Valid data bits 0 - 7*	Valid data bits 0 - 7
Low	High	Low	Valid data bits 8 - 15	Valid data bits 8 - 15*

**NOTE:**

\*These conditions are a result of current implementation and may not appear on future devices.

completed. When the processor recognizes DTACK during a read cycle, data is latched and the bus cycle terminated. When DTACK is recognized during a write cycle, the bus cycle is terminated. (Refer to **Asynchronous Versus Synchronous Operation**).

### Bus Arbitration Control

The three signals, bus request, bus grant, and bus grant acknowledge, form a bus arbitration circuit to determine which device will be the bus master device.

**Bus Request (BR)** — This input is wire ORed with all other devices that could be bus masters. This input indicates to the processor that some other device desires to become the bus master.

**Bus Grant (BG)** — This output indicates to all other potential bus master devices that the

processor will release bus control at the end of the current bus cycle.

**Bus Grant Acknowledge (BGACK)** — This input indicates that some other device has become the bus master. This signal should not be asserted until the following four conditions are met:

1. a bus grant has been received,
2. address strobe is inactive which indicates that the microprocessor is not using the bus,
3. data transfer acknowledge is inactive which indicates that neither memory nor peripherals are using the bus, and
4. bus grant acknowledge is inactive which indicates that no other device is still claiming bus mastership.

## 16-/32-Bit Microprocessor

## SCN68000

**Interrupt Control ( $\overline{IPL0}$ ,  $\overline{IPL1}$ ,  $\overline{IPL2}$ )**

These input pins indicate the encoded priority level of the device requesting an interrupt. Level seven is the highest priority while level zero indicates that no interrupts are requested. Level seven cannot be masked. The least significant bit is given in  $\overline{IPL0}$  and the most significant bit is contained in  $\overline{IPL2}$ . These lines must remain stable until the processor signals interrupt acknowledge (FC0 – FC2 are all high) to insure that the interrupt is recognized.

**System Control**

The system control inputs are used to either reset or halt the processor and to indicate to the processor that bus errors have occurred. The three system control inputs are explained in the following paragraphs.

**Bus Error (BERR)** — This input informs the processor that there is a problem with the cycle currently being executed. Problems may be a result of:

1. nonresponding devices,
2. interrupt vector number acquisition failure,
3. illegal access request as determined by a memory management unit, or
4. other application dependent errors.

The bus error signal interacts with the halt signal to determine if the current bus cycle should be re-executed or if exception processing should be performed.

Refer to **Bus Error and Halt Operation** for additional information about the interaction of the bus error and halt signals.

**Reset (RESET)** — This bidirectional signal line acts to reset (start a system initialization sequence) the processor in response to an external reset signal. An internally generated reset (result of a RESET instruction) causes all external devices to be reset and the internal state of the processor is not affected. A total system reset (processor and external devices) is the result of external HALT and RESET signals applied at the same time. Refer to **Reset Operation** for further information.

**Halt (HALT)** — When this bidirectional line is driven by an external device, it will cause the processor to stop at the completion of the current bus cycle. When the processor has been halted using this input, all control signals are inactive and all 3-State lines are put in their high-impedance state (refer to Table 15). Refer to **Bus Error and Halt Operation** for additional information about the interaction between the HALT and bus error signals.

When the processor has stopped executing instructions, such as in a double bus fault condition (refer to **Double Bus Faults**), the

HALT line is driven by the processor to indicate to external devices that the processor has stopped.

**Peripheral Control**

These control signals are used to allow the interfacing of synchronous peripheral devices with the asynchronous SCN68000. These signals are explained in the following paragraphs.

**Enable (E)** — This signal is the standard enable signal common to all synchronous type peripheral devices. The period for this output is ten SCN68000 clock periods (six clocks low, four clocks high). Enable is generated by an internal ring counter which may come up in any state (i.e., at power on, it is impossible to guarantee phase relationship of E to CLK). E is a free-running clock and runs regardless of the state of the bus on the MPU.

**Valid Peripheral Address (VPA)** — This input indicates that the device or region addressed is a synchronous family device and that data transfer should be synchronized with the enable (E) signal. This input also indicates that the processor should use automatic vectoring for an interrupt. Refer to **Interface with Synchronous Peripherals**.

**Valid Memory Address (VMA)** — This output is used to indicate to synchronous peripheral devices that there is a valid address on the address bus and the processor is synchronized to enable. This signal only responds to a valid peripheral address (VPA) input which indicates that the peripheral is a synchronous family device.

**Processor Status (FC0, FC1, FC2)**

These function code outputs indicate the state (user or supervisor) and the cycle type currently being executed, as shown in Table 14. The information indicated by the function code outputs is valid whenever address strobe ( $\overline{AS}$ ) is active.

**Table 14. Function Code Outputs**

FUNCTION CODE OUTPUT			CYCLE TYPE
FC2	FC1	FC0	
Low	Low	Low	(Undefined, reserved)
Low	Low	High	User data
Low	High	Low	User program
Low	High	High	(Undefined, reserved)
High	Low	Low	(Undefined, reserved)
High	Low	High	Supervisor data
High	High	Low	Supervisor program
High	High	High	Interrupt acknowledge

**Clock (CLK)**

The clock input is a TTL-compatible signal that is internally buffered for development of the internal clocks needed by the processor. The clock input should not be gated off at any time and the clock signal must conform to minimum and maximum pulse width times.

**Signal Summary**

Table 15 is a summary of all the signals discussed in the previous paragraphs.

**Bus Operation**

The following paragraphs explain control signal and bus operation during data transfer operations, bus arbitration, bus error and halt conditions, and reset operation.

**Data Transfer Operations**

Transfer of data between devices involves the following leads:

1. address bus A1 through A23,
2. data bus D0 through D15, and
3. control signals.

The address and data buses are separate parallel buses used to transfer data using an asynchronous bus structure. In all cycles, the bus master assumes responsibility for deskewing all signals it issues at both the start and end of a cycle. In addition, the bus master is responsible for deskewing the acknowledge and data signals from the slave device.

The following paragraphs explain the read, write, and read-modify-write cycles. The indivisible read-modify-write cycle is the method used by the SCN68000 for interlocked multi-processor communications.

**Read Cycle** — During a read cycle, the processor receives data from the memory or a peripheral device. The processor reads bytes of data in all cases. If the instruction specifies a word (or double word) operation, the processor reads both upper and lower bytes simultaneously by asserting both upper and lower data strobes. When the instruction specifies byte operation, the processor uses an internal A0 bit to determine which byte to read and then issues the data strobe required for that byte. For byte operations, when the A0 bit equals zero, the upper data strobe is issued. When the A0 bit equals one, the lower data strobe is issued. When the data is received, the processor correctly positions it internally.

A word read cycle flowchart is given in figure 9. A byte read cycle flowchart is given in Figure 10. Read cycle timing is given in Figure 11. Figure 12 details word and byte read cycle operations.

## 16-/32-Bit Microprocessor

SCN68000

Table 15. Signal Summary

SIGNAL NAME	MNEMONIC	INPUT/OUTPUT	ACTIVE STATE	HI-Z	
				on $\overline{\text{HALT}}$	on $\overline{\text{BGACK}}$
Address bus	A1 – A23	Output	High	Yes	Yes
Data bus	D0 – D15	Input/output	High	Yes	Yes
Address strobe	$\overline{\text{AS}}$	Output	Low	No	Yes
Read/write	R/ $\overline{\text{W}}$	Output	Read-high Write-low	No	Yes
Upper and lower data strobes	$\overline{\text{UDS}}$ , $\overline{\text{LDS}}$	Output	Low	No	Yes
Data transfer acknowledge	$\overline{\text{DTACK}}$	Input	Low	No	No
Bus request	$\overline{\text{BR}}$	Input	Low	No	No
Bus grant	$\overline{\text{BG}}$	Output	Low	No	No
Bus grant acknowledge	$\overline{\text{BGACK}}$	Input	Low	No	No
Interrupt priority level	$\overline{\text{IPL0}}$ , $\overline{\text{IPL1}}$ , $\overline{\text{IPL2}}$	Input	Low	No	No
Bus error	$\overline{\text{BERR}}$	Input	Low	No	No
Reset	$\overline{\text{RESET}}$	Input/output	Low	No <sup>1</sup>	No <sup>1</sup>
Halt	$\overline{\text{HALT}}$	Input/output	Low	No <sup>1</sup>	No <sup>1</sup>
Enable	E	Output	High	No	No
Valid memory address	$\overline{\text{VMA}}$	Output	Low	No	Yes
Valid peripheral address	$\overline{\text{VPA}}$	Input	Low	No	No
Function code output	FC0, FC1, FC2	Output	High	No <sup>2</sup>	Yes
Clock	CLK	Input	High	No	No
Power input	V <sub>CC</sub>	Input	–	–	–
Ground	GND	Input	–	–	–

**NOTES:**

1. Open Drain
2. Function codes are placed in high-impedance state during HALT.

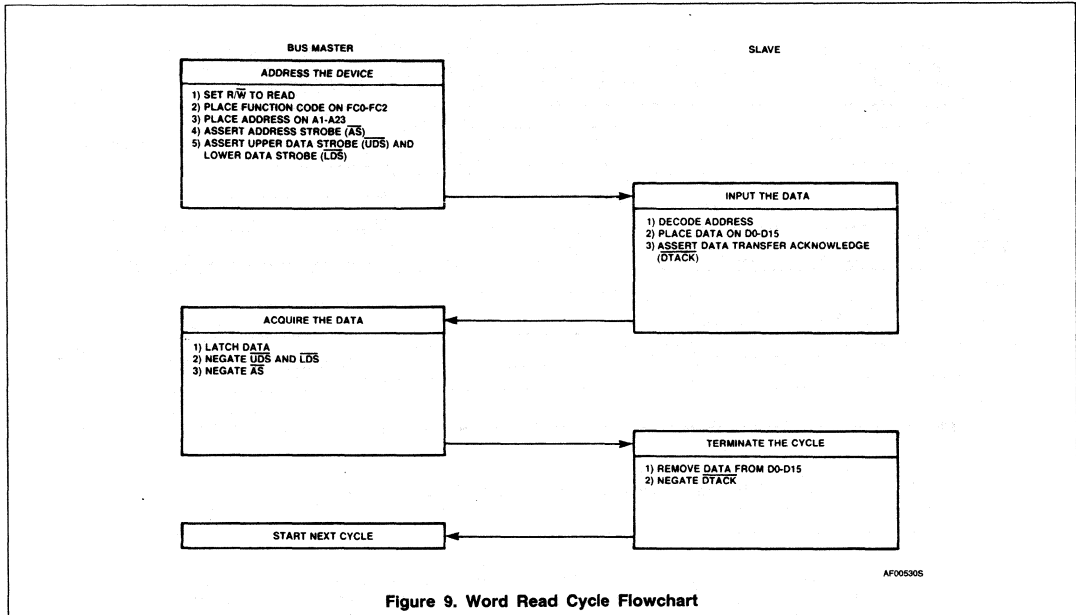

Figure 9. Word Read Cycle Flowchart



Figure 10. Byte Read Cycle Flowchart

16-/32-Bit Microprocessor

SCN68000

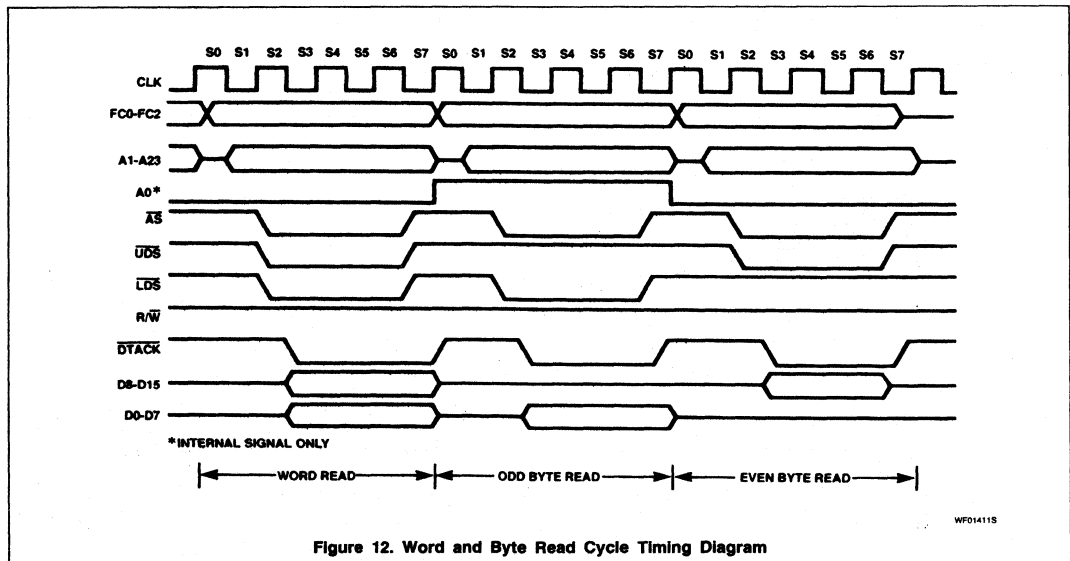
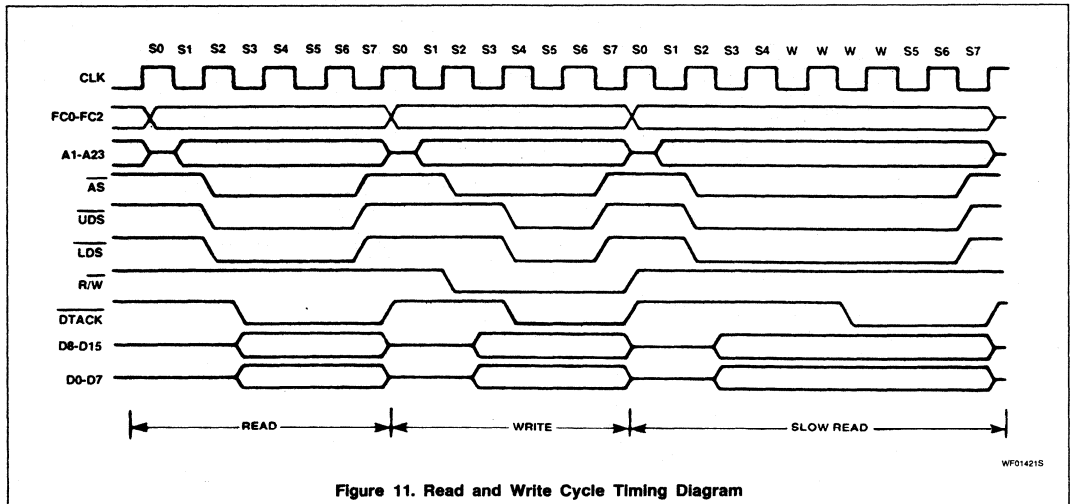



# 16-/32-Bit Microprocessor

SCN68000

**Write Cycle** — During a write cycle, the processor sends data to either the memory or a peripheral device. The processor writes bytes of data in all cases. If the instruction specifies a word operation, the processor writes both bytes. When the instruction speci-

fies a byte operation, the processor uses an internal A0 bit to determine which byte to write and then issues the data strobe required for that byte. For byte operations, when the A0 bit equals zero, the upper data strobe is issued. When the A0 bit equals one, the lower

data strobe is issued. A word write cycle flowchart is given in Figure 13. A byte write cycle flowchart is given in Figure 14. Write cycle timing is given in Figure 11. Figure 15 details word and byte write cycle operation.

2

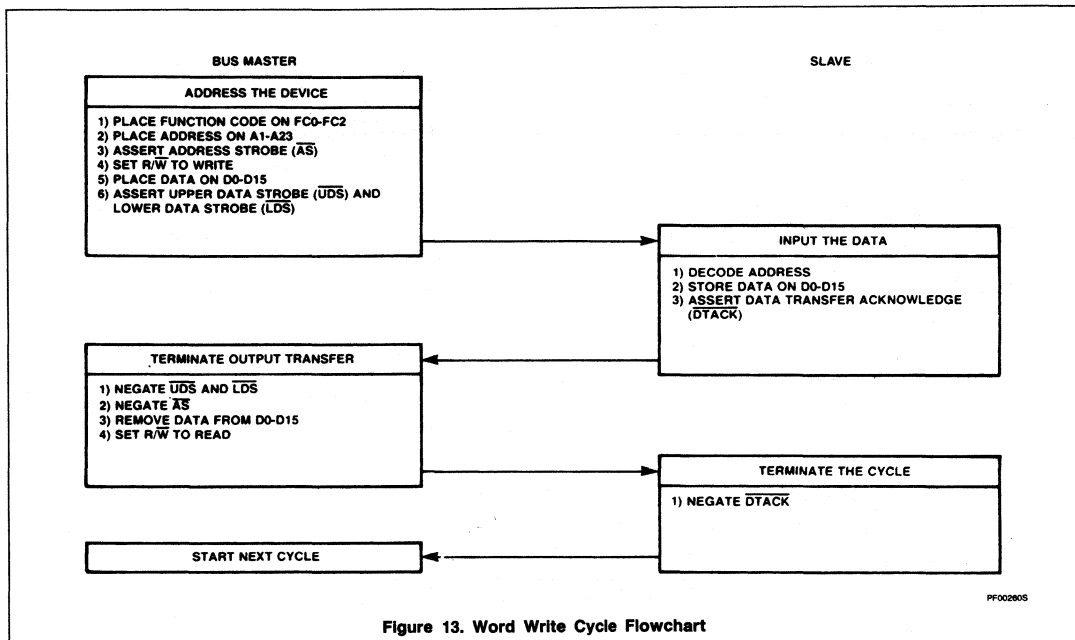

Figure 13. Word Write Cycle Flowchart

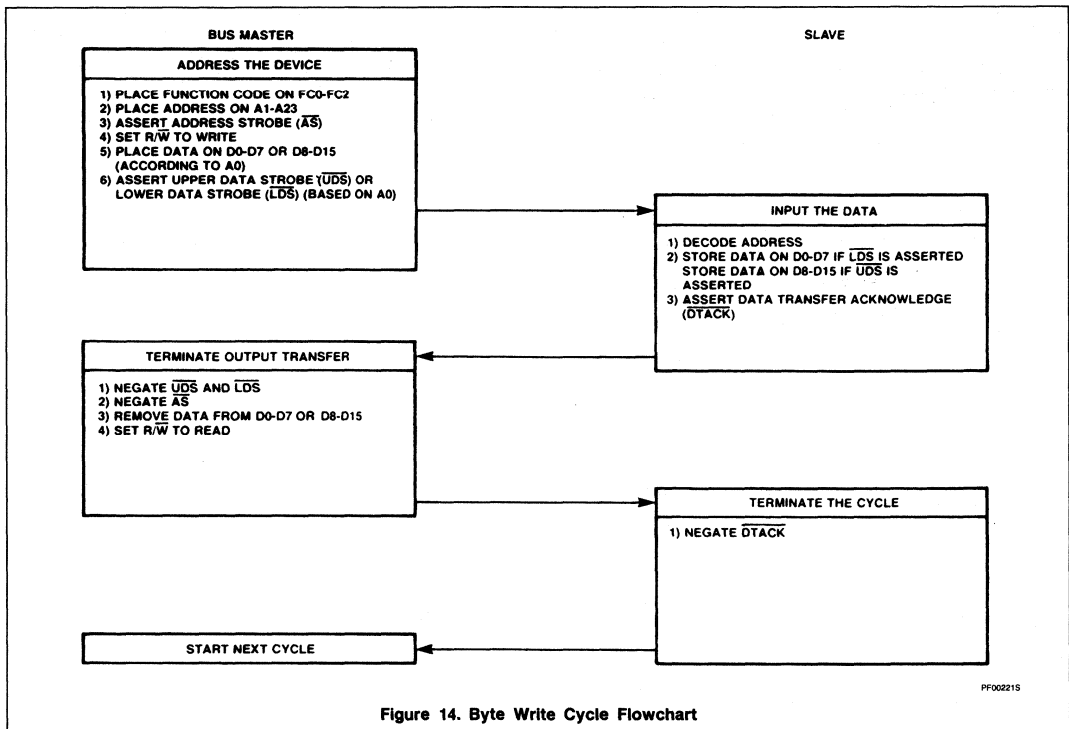

Figure 14. Byte Write Cycle Flowchart

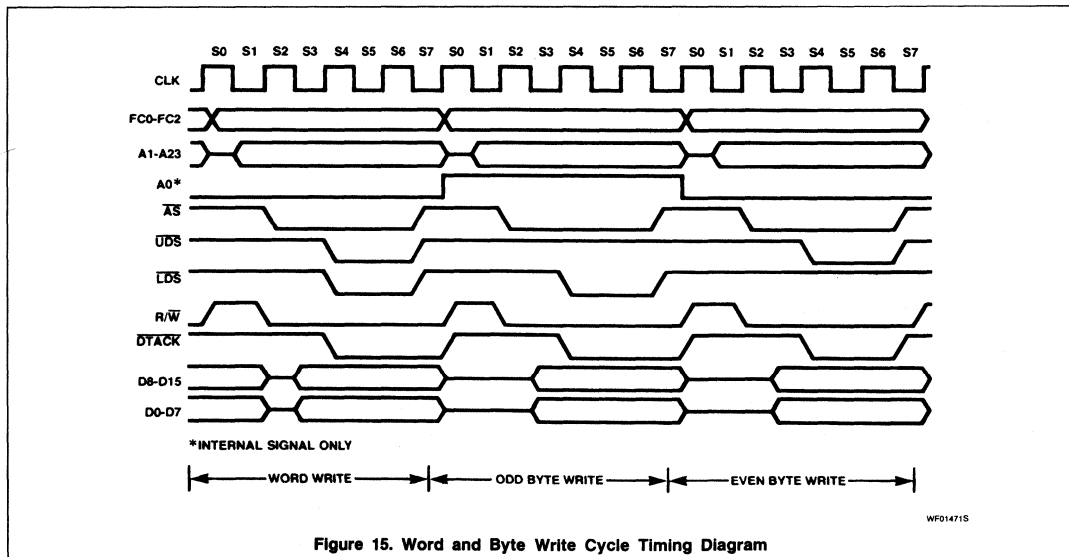

Figure 15. Word and Byte Write Cycle Timing Diagram

# 16-/32-Bit Microprocessor

# SCN68000

**Read-Modify-Write Cycle** — The read-modify-write cycle performs a read, modifies the data in the arithmetic-logic unit, and writes the data back to the same address. In the SCN68000, this cycle is indivisible in that the address strobe is asserted throughout the

entire cycle. The test and set (TAS) instruction uses this cycle to provide meaningful communication between processors in a multiple processor environment. This instruction is the only instruction that uses the read-modify-write cycles and since the test and set

instruction only operates on bytes, all read-modify-write cycles are byte operations. A read-modify-write cycle flowchart is given in Figure 16 and a timing diagram is given in Figure 17.

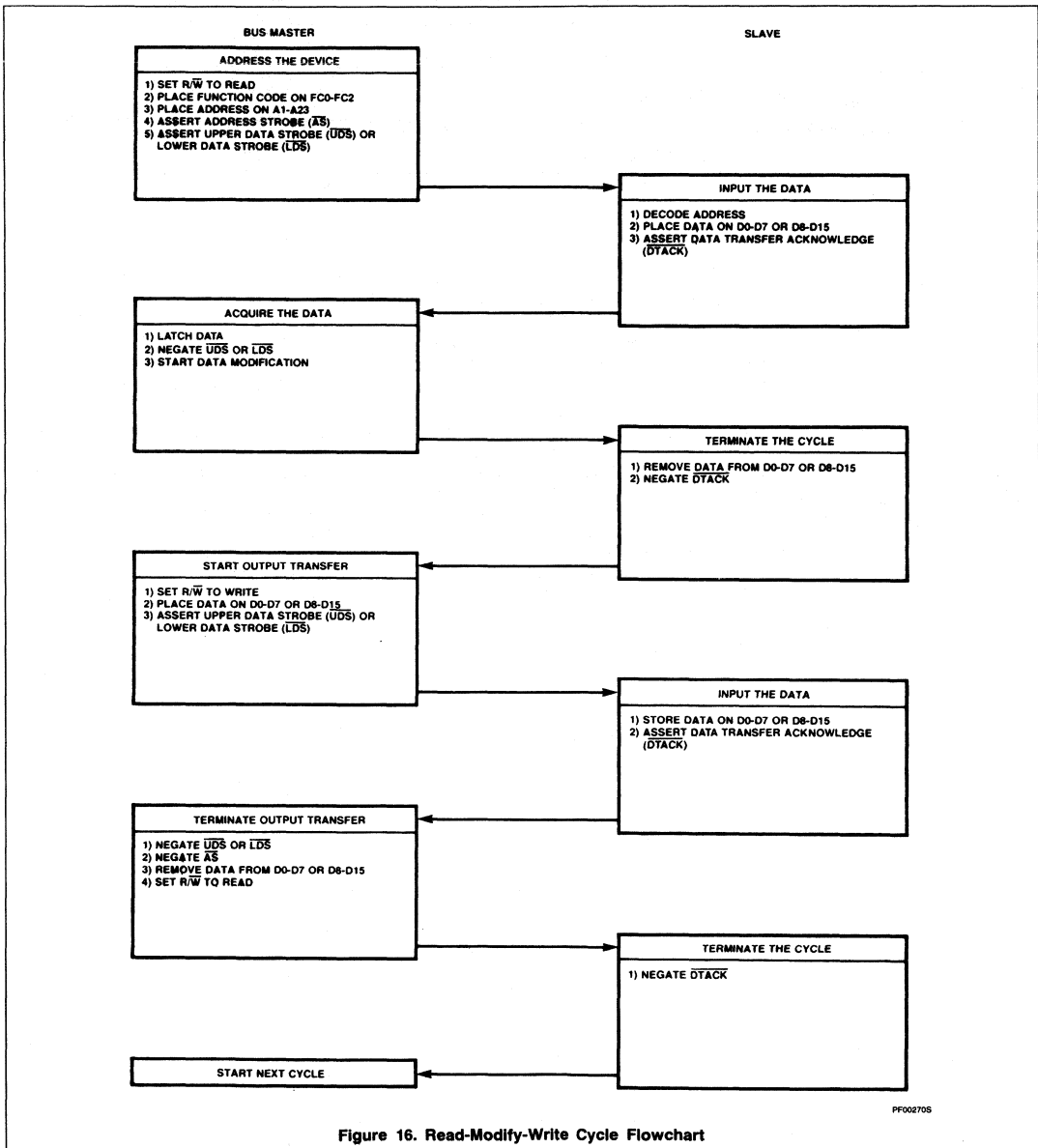

Figure 16. Read-Modify-Write Cycle Flowchart

## 16-/32-Bit Microprocessor

SCN68000

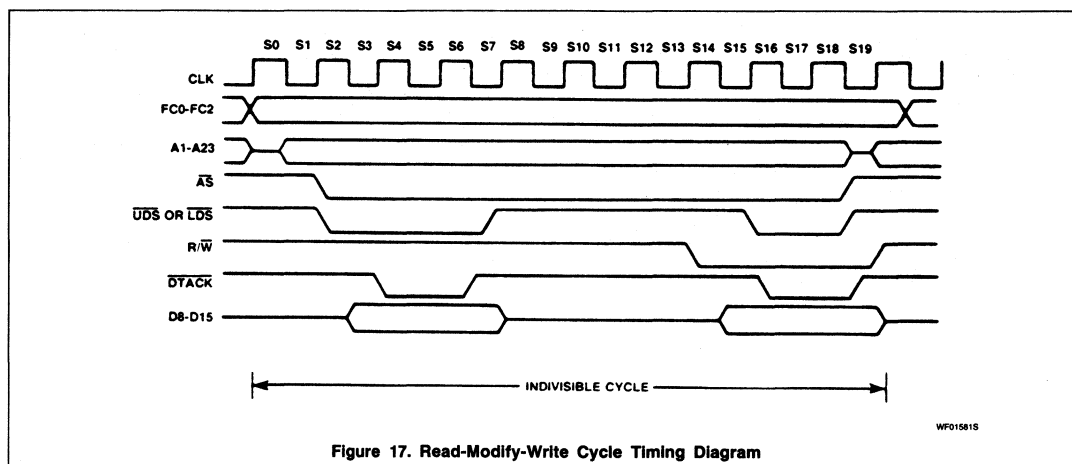

Figure 17. Read-Modify-Write Cycle Timing Diagram

**Bus Arbitration**

Bus arbitration is a technique used by master-type devices to request, be granted, and acknowledge bus mastership. In its simplest form, it consists of the following:

1. asserting a bus mastership request,
2. receiving a grant that the bus is available at the end of the current cycle, and
3. acknowledging that mastership has been assumed.

Figure 18 is a flowchart showing the detail involved in a request from a single device. Figure 19 is a timing diagram for the same

operation. This technique allows processing of bus requests during data transfer cycles.

The timing diagram shows that the bus request is negated at the time that an acknowledge is asserted. This type of operation would be true for a system consisting of the processor and one device capable of bus mastership. In systems having a number of devices capable of bus mastership, the bus request line from each device is wire-ORed to the processor. In this system, it is easy to see that there could be more than one bus request being made. The timing diagram

shows that the bus grant signal is negated a few clock cycles after the transition of the acknowledge (BGACK) signal.

However, if the bus requests are still pending, the processor will assert another bus grant within a few clock cycles after it was negated. This additional assertion of bus grant allows external arbitration circuitry to select the next bus master before the current bus master has completed its requirements. The following paragraphs provide additional information about the three steps in the arbitration process.

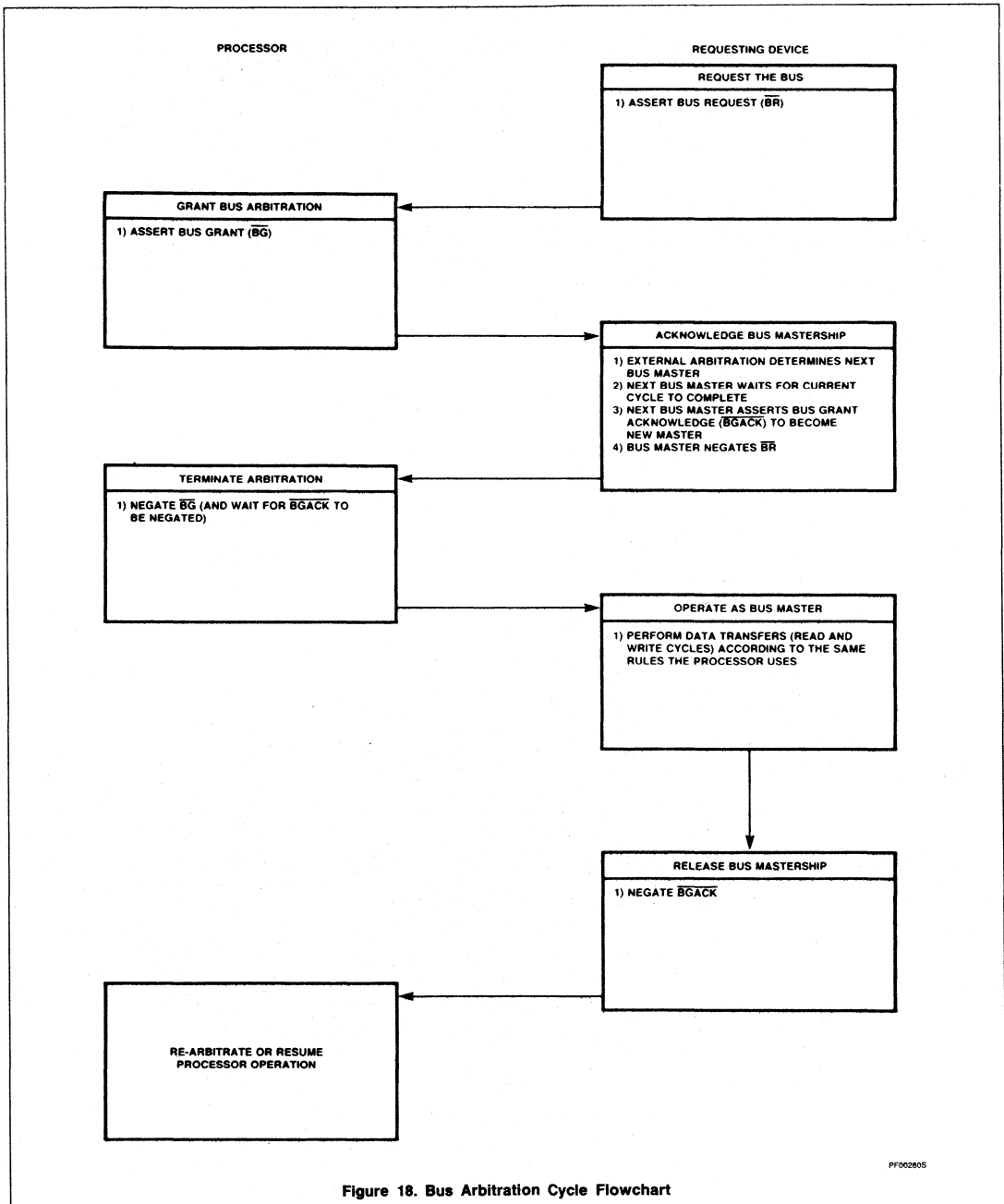

Figure 18. Bus Arbitration Cycle Flowchart

PF002805

## 16-/32-Bit Microprocessor

SCN68000

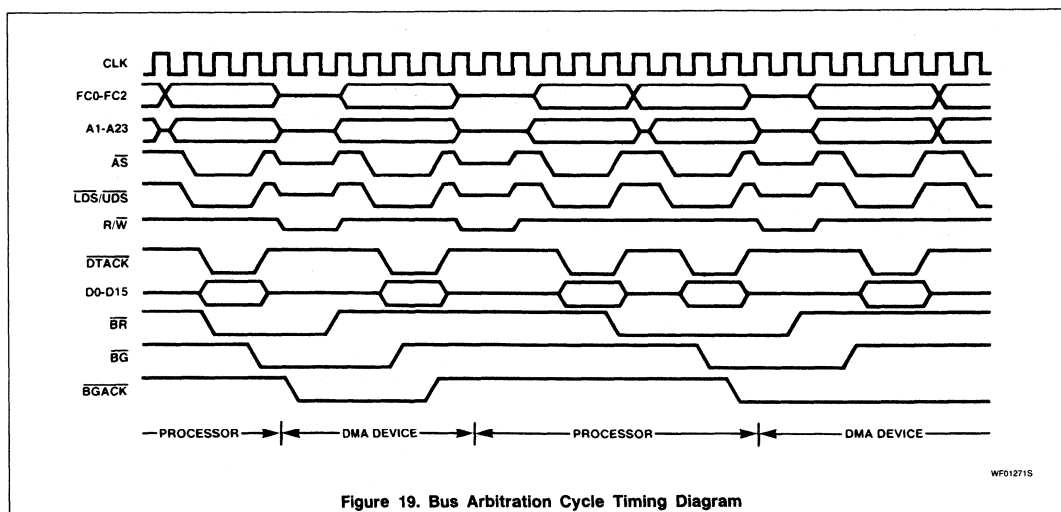

Figure 19. Bus Arbitration Cycle Timing Diagram

**Requesting the Bus** — External devices capable of becoming bus masters request the bus by asserting the bus request ( $\overline{BR}$ ) signal. This is a wire-ORed signal (although it need not be constructed from open-collector devices) that indicates to the processor that some external device requires control of the external bus. The processor is effectively at a lower bus priority level than the external device and will relinquish the bus after it has completed the last bus cycle it has started.

When no acknowledge is received before the bus request signal goes inactive, the processor will continue processing when it detects that the bus request is inactive. This allows ordinary processing to continue if the arbitration circuitry responded to noise inadvertently.

**Receiving the Bus Grant** — The processor asserts bus grant ( $\overline{BG}$ ) as soon as possible. Normally this is immediately after internal synchronization. The only exception to this occurs when the processor has made an internal decision to execute the next bus cycle but has not progressed far enough into the cycle to have asserted the address strobe ( $\overline{AS}$ ) signal. In this case, bus grant will be delayed until  $\overline{AS}$  is asserted to indicate to

external devices that a bus cycle is being executed.

The bus grant signal may be routed through a daisy-chained network or through a specific priority-encoded network. The processor is not affected by the external method of arbitration as long as the protocol is obeyed.

**Acknowledgement of Mastership** — Upon receiving a bus grant, the requesting device waits until address strobe, data transfer acknowledge, and bus grant acknowledge are negated before issuing its own  $\overline{BGACK}$ . The negation of the address strobe indicates that the previous master has completed its cycle; the negation of bus grant acknowledge indicates that the previous master has released the bus. (While address strobe is asserted, no device is allowed to "break into" a cycle.) The negation of data transfer acknowledge indicates the previous slave has terminated its connection to the previous master. Note that in some applications data transfer acknowledge might not enter into this function. General purpose devices would then be connected such that they were only dependent on address strobe. When bus grant acknowledge is issued, the device is a bus master until it negates bus grant acknowledge. Bus

grant acknowledge should not be negated until after the bus cycle(s) is (are) completed. Bus mastership is terminated at the negation of bus grant acknowledge.

The bus request from the granted device should be dropped after bus grant acknowledge is asserted. If a bus request is still pending, another bus grant will be asserted within a few clocks of the negation of the bus grant. Refer to **Bus Arbitration Control**. Note that the processor does not perform any external bus cycles before it re-asserts bus grant.

#### Bus Arbitration Control

The bus arbitration control unit in the SCN68000 is implemented with a finite state machine. A state diagram of this machine is shown in Figure 20. All asynchronous signals to the SCN68000 are synchronized before being used internally. This synchronization is accomplished in a maximum of one cycle of the system clock, assuming that the asynchronous input setup time (#47) has been met (see Figure 21). The input signal is sampled on the falling edge of the clock and is valid internally after the next falling edge.

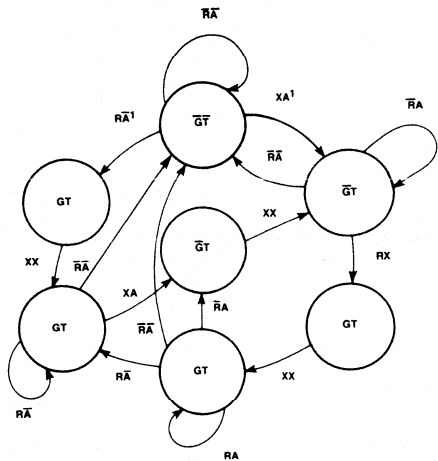

AF007405

a. State Diagram for Mask Sets Previous to GN7

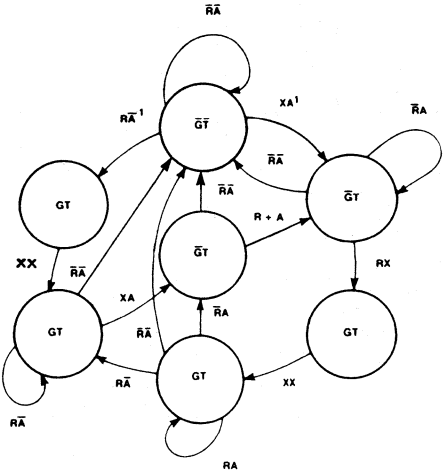

AF006315

b. State Diagram for GN7 and Later Mask Sets

NOTES:

R = Bus request internal

A = Bus grant acknowledge internal

G = Bus grant

T = 3-State control to bus control logic<sup>2</sup>

X = Don't care

1. State machine will not change if the bus is S0 or S1. Refer to Bus Arbitration Control.

2. The address bus will be placed in the high-impedance state if T is asserted and AS-bar is negated.

Figure 20. SCN68000 Bus Arbitration Unit State Diagram

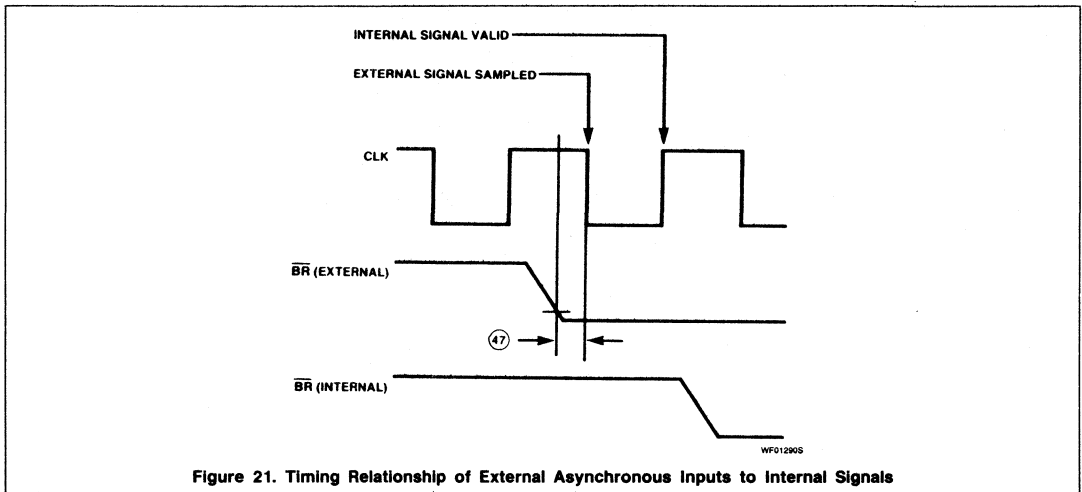

Figure 21. Timing Relationship of External Asynchronous Inputs to Internal Signals

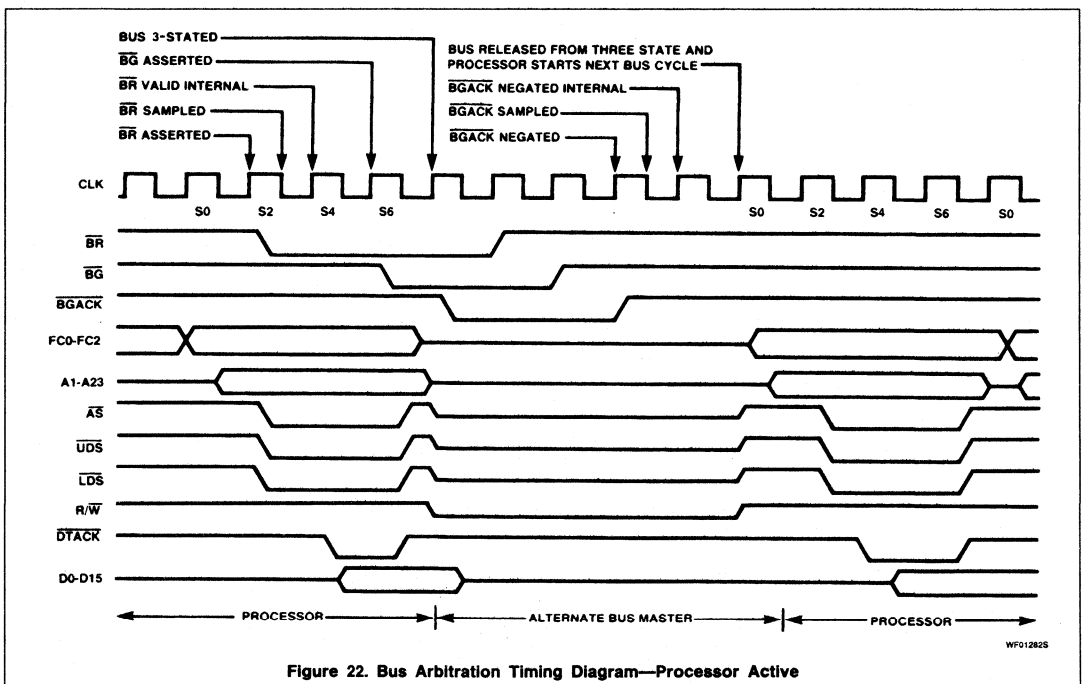

Figure 22. Bus Arbitration Timing Diagram—Processor Active



## 16-/32-Bit Microprocessor

SCN68000

As shown in Figure 20, input signals labeled R and A are internally synchronized on the bus request and bus grant acknowledge pins, respectively. The bus grant output is labeled G and the internal 3-State control signal T. If T is true, the address, data, and control buses are placed in a high-impedance state when  $\overline{AS}$  is negated. All signals are shown in positive logic (active high) regardless of their true active voltage level. State changes (valid outputs) occur on the next rising edge after the internal signal is valid.

A timing diagram of the bus arbitration sequence during a processor bus cycle is shown in Figure 22. The bus arbitration sequence while the bus is inactive (i.e., executing internal operations such as a multiply instruction) is shown in Figure 23.

If a bus request is made at a time when the MPU has already begun a bus cycle but  $\overline{AS}$  has not been asserted (bus state S0),  $\overline{BG}$  will not be asserted on the next rising edge. Instead,  $\overline{BG}$  will be delayed until the second rising edge following its internal assertion. This sequence is shown in Figure 24.

**Bus Error and Halt Operation**

In a bus architecture that requires a handshake from an external device, the possibility exists that the handshake might not occur. Since different systems will require a different maximum response time, a bus error input is provided. External circuitry must be used to determine the duration between address strobe and data transfer acknowledge before issuing a bus error signal. When a bus error signal is received, the processor has two options: initiate a bus error exception sequence or try running the bus cycle again.

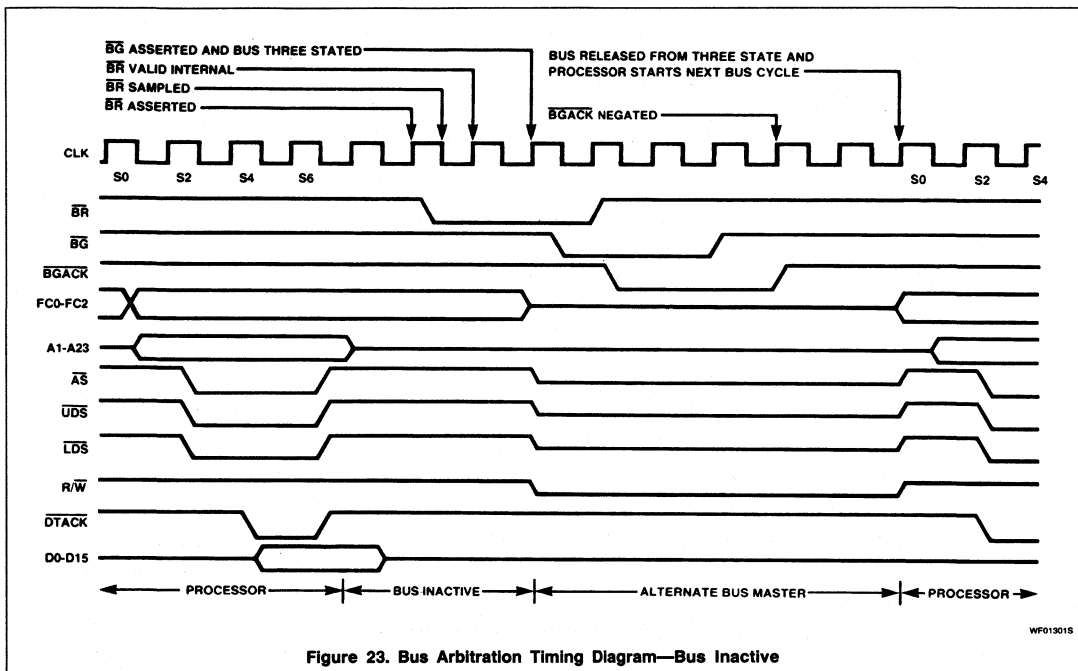

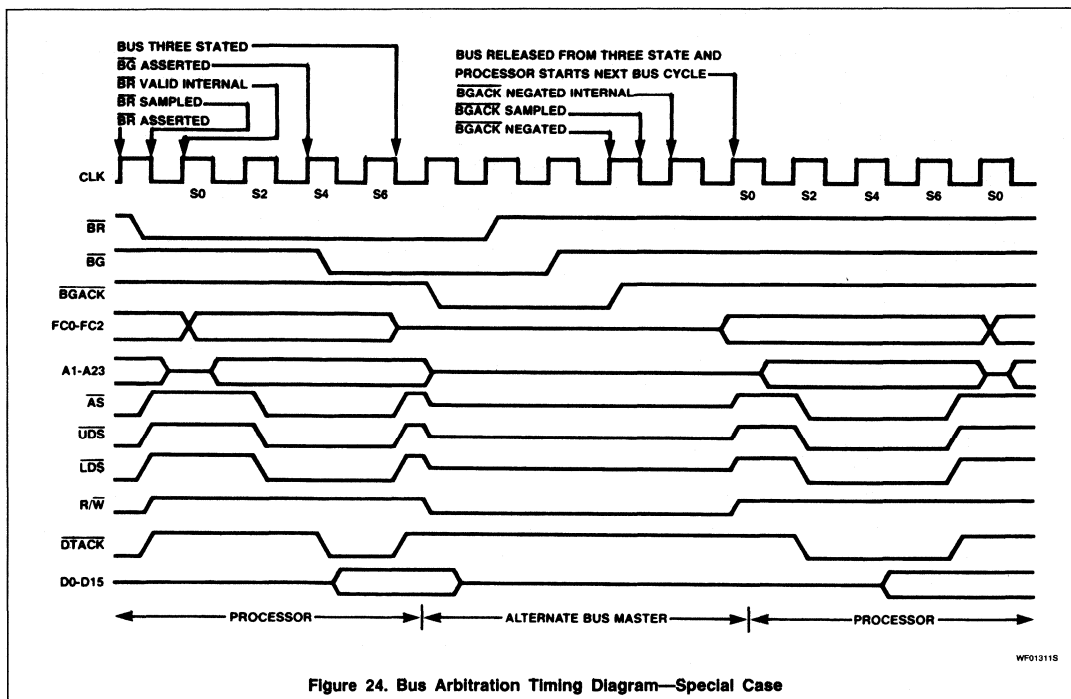

Figure 24. Bus Arbitration Timing Diagram—Special Case

**Bus Error Operation** — When the bus error signal is asserted, the current bus cycle is terminated. If BERR is asserted before the falling edge of S2, AS will be negated in S7 in either a read or write cycle. As long as BERR remains asserted, the data and address buses will be in the high-impedance state. When BERR is negated, the processor will begin stacking for exception processing. Figure 25 is a timing diagram for the exception sequence. The sequence is composed of the following elements:

1. stacking the program counter and status register,
2. stacking the error information,
3. reading the bus error vector table entry, and
4. executing the bus error handler routine.

The stacking of the program counter and the status register is the same as if an interrupt had occurred. Several additional items are stacked when a bus error occurs. These items are used to determine the nature of the

error and correct it, if possible. The bus error vector is vector number two located at address \$000008. The processor loads the new program counter from this location. A software bus error handler routine is then executed by the processor. Refer to **Exception Processing** for additional information.

**Re-Run Operation** — When, during a bus cycle, the processor receives a bus error signal and the halt pin is being driven by an external device, the processor enters the re-run sequence. Figure 26 is a timing diagram for re-running the bus cycle.

The processor terminates the bus cycle, then puts the address and data output lines in the high-impedance state. The processor remains "halted", and will not run another bus cycle until the halt signal is removed by external logic. Then the processor will re-run the previous cycle using the same function codes, the same data (for a write operation), and the same controls. The bus error signal should be removed at least one clock cycle before the halt signal is removed.

**NOTE:**  
The processor will not re-run a read-modify-write cycle. This restriction is made to guarantee that the entire cycle runs correctly and that the write operation of a test-and-set operation is performed without over releasing AS. If BERR and HALT are asserted during a read-modify-write bus cycle, a bus error operation results.

**Halt Operation** — The halt input signal to the SCN68000 performs a halt/run/single-step function in a similar fashion to the synchronous device halt function. The halt and run modes are somewhat self-explanatory in that when the halt signal is constantly active the processor "halts" (does nothing) and when the halt signal is constantly inactive the processor "runs" (does something).

This single-step mode is derived from correctly timed transitions on the halt signal input. It forces the processor to execute a single bus cycle by entering the run mode until the processor starts a bus cycle then changing to the halt mode. Thus, the single-step mode allows the user to proceed through (and therefore debug) processor operations one bus cycle at a time.

16-/32-Bit Microprocessor

SCN68000

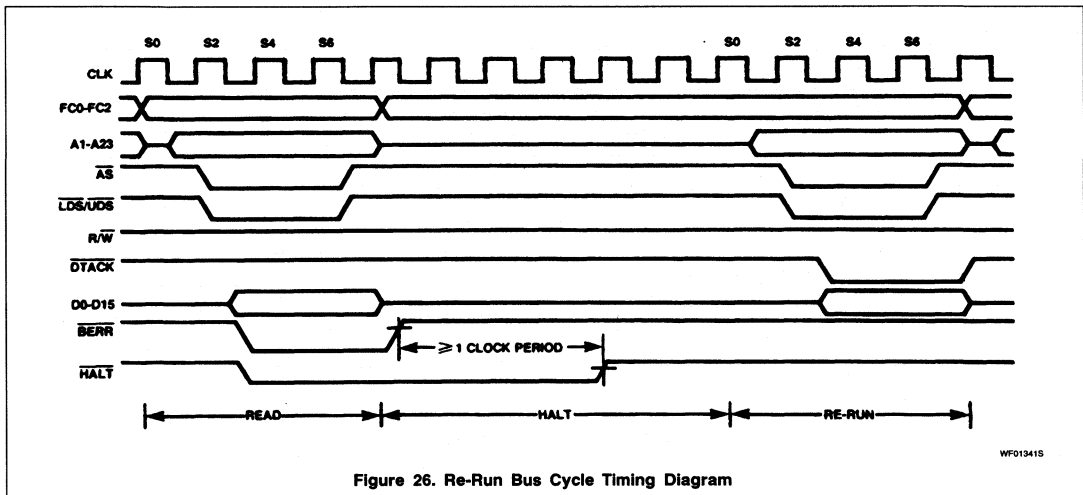
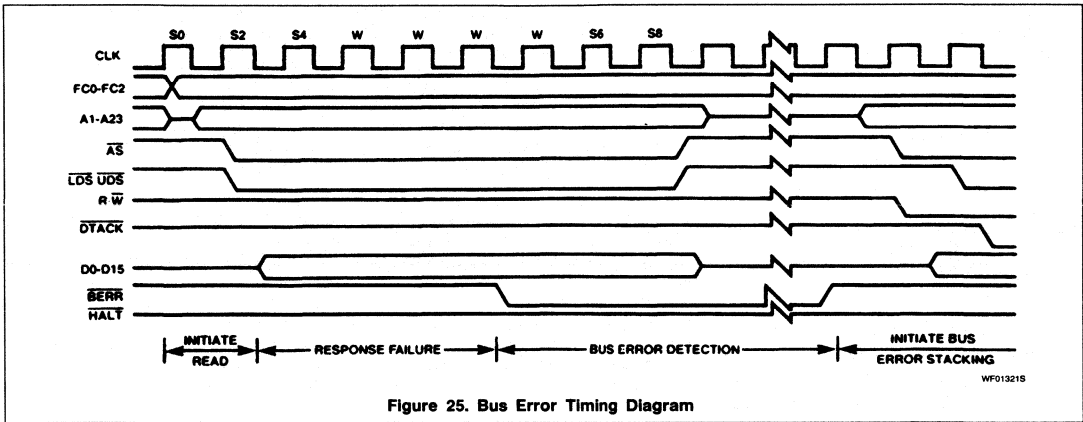

# 16-/32-Bit Microprocessor

SCN68000

Figure 27 details the timing required for correct single-step operations. Some care must be exercised to avoid harmful interactions between the bus error signal and the halt pin when using the single-cycle mode as a debugging tool. This is also true of interactions between the halt and reset lines since these can reset the machine.

When the processor completes a bus cycle after recognizing that the halt signal is active, most 3-State signals are put in the high-impedance state, these include:

1. address lines, and
2. data lines.

This is required for correct performance of the re-run bus cycle operation.

While the processor is honoring the halt request, bus arbitration performs as usual.

That is, halting has no effect on bus arbitration. It is the bus arbitration function that removes the control signals from the bus.

The halt function and the hardware trace capability allow the hardware debugger to trace single bus cycles or single instructions at a time. These processor capabilities, along with a software debugging package, give total debugging flexibility.

**Double Bus Faults** — When a bus error exception occurs, the processor will attempt to stack several words containing information about the state of the machine. If a bus error exception occurs during the stacking operation, there have been two bus errors in a row. This is commonly referred to as a double bus fault. When a double bus fault occurs, the processor will halt. Once a bus error exception has occurred, any bus error exception

occurring before the execution of the next instruction constitutes a double bus fault.

Note that a bus cycle which is re-run does not constitute a bus error exception and does not contribute to a double bus fault. Note also that this means that as long as the external hardware requests it, the processor will continue to re-run the same bus cycle.

The bus error pin also has an effect on processor operation after the processor receives an external reset input. The processor reads the vector table after a reset to determine the address to start program execution. If a bus error occurs while reading the vector table (or at any time before the first instruction is executed), the processor reacts as if a double bus fault has occurred and it halts. Only an external reset will start a halted processor.

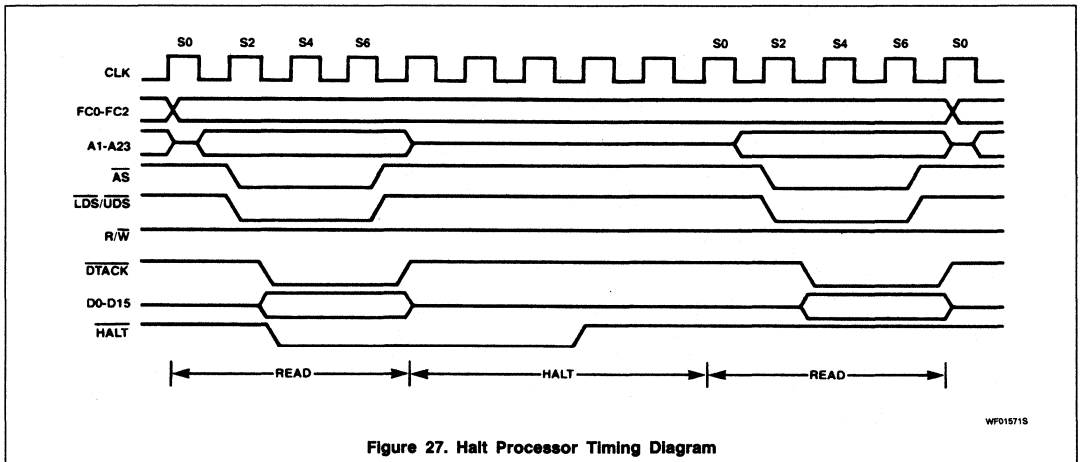

Figure 27. Halt Processor Timing Diagram

WF01571S

# 16-/32-Bit Microprocessor

# SCN68000

2

### Reset Operation

The reset signal is a bidirectional signal that allows either the processor or an external signal to reset the system. Figure 28 is a timing diagram for the reset operation. Both the halt and reset lines must be asserted to ensure total reset of the processor.

When the reset and halt lines are driven by an external device, it is recognized as an entire system reset, including the processor. The processor responds by reading the reset vector table entry (vector number zero, ad-

dress \$000000) and loads it into the supervisor stack pointer (SSP). Vector table entry number one at address \$000004 is read next and loaded into the program counter. The processor initializes the status register to an interrupt level of seven. No other registers are affected by the reset sequence.

When a reset instruction is executed, the processor drives the reset pin for 124 clock periods. In this case, the processor is trying to reset the rest of the system. Therefore, there is no effect on the internal state of the

processor. All of the processor's internal registers and the status register are unaffected by the execution of a reset instruction. All external devices connected to the reset line will be reset at the completion of the reset instruction.

Asserting the reset and halt lines for ten clock cycles will cause a processor reset, except when  $V_{CC}$  is initially applied to the processor. In this case, an external reset must be applied for at least 100ms.

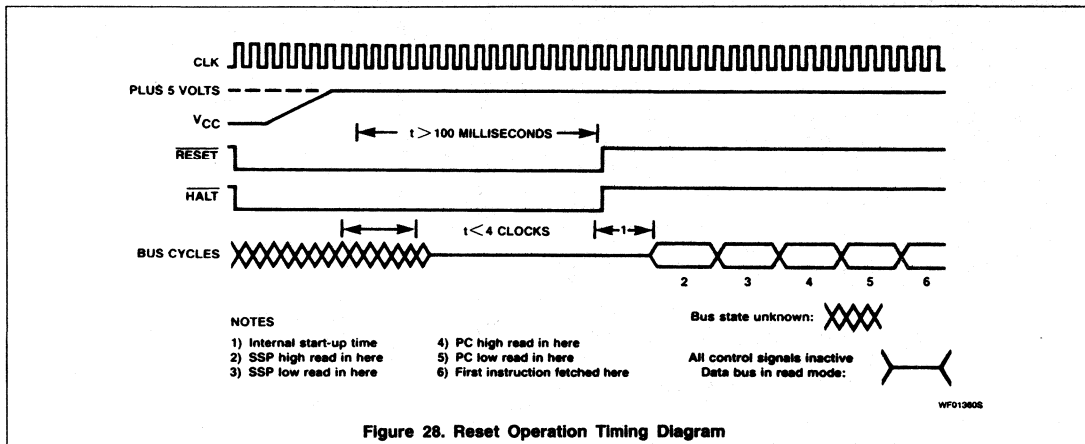

Figure 28. Reset Operation Timing Diagram

## 16-/32-Bit Microprocessor

SCN68000

**The Relationship of DTACK, BERR, and HALT**

In order to properly control termination of a bus cycle for a re-run or a bus error condition, DTACK, BERR, and HALT should be asserted and negated on the rising edge of the SCN68000 clock. This will assure that when two signals are asserted simultaneously, the required setup time (#47) for both of them will be met during the same bus state.

This, or some equivalent precaution, should be designed external to the SCN68000. Parameter #48 (see AC Electrical Characteristics for # references) is intended to ensure this operation in a totally asynchronous system, and may be ignored if the above conditions are met.

The preferred bus cycle terminations may be summarized as follows (case numbers refer to Table 16):

Normal Termination:

DTACK occurs first (case 1).

Halt Termination:

HALT is asserted at the same time or before DTACK and BERR remains negated (cases 2 and 3).

Bus Error Termination:

BERR is asserted in lieu of, at the same time, or before DTACK (case 4); BERR is negated at the same time or after DTACK.

Re-Run Termination:

HALT and BERR are asserted in lieu of, at the same time, or before DTACK (cases 6 and 7); HALT must be held at least one cycle after BERR. Case 5 indicates BERR may precede HALT.

Table 16 details the resulting bus cycle termination under various combinations of control signal sequences. The negation of these same control signals under several conditions is shown in Table 17 (DTACK is assumed to be negated normally in all cases; for best results, both DTACK and BERR should be negated when address strobe is negated).

**EXAMPLE A:**

A system uses a watch-dog timer to terminate accesses to unpopulated address space. The timer asserts DTACK and BERR simultaneously after time out (case 4).

**EXAMPLE B:**

A system uses error detection on RAM contents. Designer may (a) delay DTACK until data verified and return BERR and HALT simultaneously to re-run error cycle (case 6), or if valid, return DTACK (case 1); (b) delay DTACK until data verified and return BERR at same time as DTACK if data in error (case 4).

**Table 16. DTACK, BERR, and HALT Assertion Results**

CASE NO.	CONTROL SIGNAL	ASSERTED ON RISING EDGE OF STATE		RESULT
		N	N + 2	
1	DTACK	A	S	Normal cycle terminate and continue.
	BERR	NA	X	
	HALT	NA	X	
2	DTACK	A	S	Normal cycle terminate and halt. Continue when HALT removed.
	BERR	NA	X	
	HALT	A	S	
3	DTACK	NA	A	Normal cycle terminate and halt. Continue when HALT removed.
	BERR	NA	NA	
	HALT	A	S	
4	DTACK	X	X	Terminate and take bus error trap.
	BERR	A	S	
	HALT	NA	NA	
5	DTACK	NA	X	Terminate and re-run.
	BERR	A	S	
	HALT	NA	A	
6	DTACK	X	X	Terminate and re-run when HALT removed.
	BERR	A	S	
	HALT	A	S	
7	DTACK	NA	X	Terminate and re-run when HALT removed.
	BERR	NA	A	
	HALT	A	S	

**NOTES:**

N – the number of the current even bus state (e.g., S4, S6, etc.)

A – signal is asserted in this bus state

NA – signal is not asserted in this state

X – don't care

S – signal was asserted in previous state and remains asserted in this state

**Table 17. BERR and HALT Negation Results**

CONDITIONS OF TERMINATION IN TABLE 16	CONTROL SIGNAL	NEGATED ON RISING EDGE OF STATE		RESULTS-NEXT CYCLE
		N	N+2	
Bus Error	BERR	• or •	•	Takes bus error trap.
	HALT	• or •	•	
Re-run	BERR	• or •	•	Illegal sequence; usually traps to vector number 0.
	HALT	•	•	
Re-run	BERR	•	•	Re-runs the bus cycle.
	HALT	• or •	•	
Normal	BERR	• or •	•	May lengthen next cycle.
	HALT	• or •	•	
Normal	BERR	• or •	•	If next cycle is started it will be terminated as a bus error.
	HALT	• or •	none	

**NOTE:**

• = Signal is negated in this bus state.

**Asynchronous Versus Synchronous Operation****Asynchronous Operation**

To achieve clock frequency independence at a system level, the SCN68000 can be used in

an asynchronous manner. This entails using only the bus handshake lines (AS, UDS, LDS, DTACK, BERR, HALT, and VPA) to control the data transfer. Using this method, AS signals the start of a bus cycle and the data strobes are used as a condition for valid data

## 16-/32-Bit Microprocessor

SCN68000

2

on a write cycle. The slave device (memory or peripheral) then responds by placing the requested data on the data bus for a read cycle or latching data on a write cycle and asserting the data transfer acknowledge signal ( $\overline{DTACK}$ ) to terminate the bus cycle. If no slave responds or the access is invalid, external control logic asserts the  $\overline{BERR}$ , or  $\overline{BERR}$  and  $\overline{HALT}$ , signal to abort or rerun the bus cycle.

The  $\overline{DTACK}$  signal is allowed to be asserted before the data from a slave device is valid on a read cycle. The length of time that  $\overline{DTACK}$  may precede data is given as parameter #31 and it must be met in any asynchronous system to insure that valid data is latched into the processor. Notice that there is no maximum time specified from the assertion of  $\overline{AS}$  to the assertion of  $\overline{DTACK}$ . This is because the MPU will insert wait cycles of one clock period each until  $\overline{DTACK}$  is recognized.

#### Synchronous Operation

To allow for those systems which use the system clock as a signal to generate  $\overline{DTACK}$  and other asynchronous inputs, the asynchronous input setup time is given as parameter #47. If this setup is met on an input, such as  $\overline{DTACK}$ , the processor is guaranteed to recognize that signal on the next falling edge of the system clock. However, the converse is not true — if the input signal does not meet the setup time it is not guaranteed not to be recognized. In addition, if  $\overline{DTACK}$  is recognized on a falling edge, valid data will be latched into the processor (on a read cycle) on the next falling edge provided that the data meets the setup time given as parameter #27. Given this, parameter #31 may be ignored. Note that if  $\overline{DTACK}$  is asserted, with the required setup time, before the falling edge of  $S4$ , no wait states will be incurred and the bus cycle will run at its maximum speed of four clock periods.

#### NOTE:

During an active bus cycle,  $\overline{VPA}$  and  $\overline{BERR}$  is sampled on every falling edge of the clock starting with  $S2$ .  $\overline{DTACK}$  is sampled on every falling edge of the clock starting with  $S4$  and data is latched on the falling edge of  $S8$  during a read. The bus cycle will then be terminated in  $S7$  except when  $\overline{BERR}$  is asserted in the absence of  $\overline{DTACK}$ , in which case it will terminate one clock cycle later in  $S9$ .  $\overline{VPA}$  is sampled only on the third falling edge of the system clock before the rising edge of the  $E$  clock.

### PROCESSING STATES

This section describes the actions of the SCN68000 which are outside the normal processing associated with the execution of instructions. The functions of the bits in the supervisor portion of the status register are covered: the supervisor/user bit, the trace enable bit, and the processor interrupt priority mask. Finally, the sequence of memory refer-

ences and actions taken by the processor on exception conditions are detailed.

The SCN68000 is always in one of three processing states: normal, exception, or halted. The normal processing state is that associated with instruction execution; the memory references are to fetch instructions and operands, and to store results. A special case of the normal state is the stopped state which the processor enters when a stop instruction is executed. In this state, no further references are made.

The exception processing state is associated with interrupts, trap instructions, tracing, and other exceptional conditions. The exception may be internally generated by an instruction or by an unusual condition arising during the execution of an instruction. Externally, exception processing can be forced by an interrupt, by a bus error, or by a reset. Exception processing is designed to provide an efficient context switch so that the processor may handle unusual conditions.

The halted processing state is an indication of catastrophic hardware failure. For example, if during the exception processing of a bus error another bus error occurs, the processor assumes that the system is unusable and halts. Only an external reset can restart a halted processor. Note that a processor in the stopped state is not in the halted state, nor vice versa.

#### Privilege States

The processor operates in one of two states of privilege: the "supervisor" state or the "user" state. The privilege state determines which operations are legal, are used to choose between the supervisor stack pointer and the user stack pointer in instruction references, and may be used by an external memory management device to control and translate accesses.

The privilege state is a mechanism for providing security in a computer system. Programs should access only their own code and data areas, and ought to be restricted from accessing information which they do not need and must not modify.

The privilege mechanism provides security by allowing most programs to execute in user state. In this state, the accesses are controlled, and the effects on other parts of the system are limited. The operating system executes in the supervisor state, has access to all resources, and performs the overhead tasks for the user state programs.

#### Supervisor State

The supervisor state is the higher state of privilege. For instruction execution, the supervisor state is determined by the  $S$  bit of the

status register; if the  $S$  bit is asserted (high), the processor is in the supervisor state. All instructions can be executed in the supervisor state. The bus cycles generated by instructions executed in the supervisor state are classified as supervisor references. While the processor is in the supervisor privilege state, those instructions which use either the system stack pointer implicitly or address register seven explicitly access the supervisor stack pointer.

All exception processing is done in the supervisor state, regardless of the setting of the  $S$  bit. The bus cycles generated during exception processing are classified as supervisor references. All stacking operations during exception processing use the supervisor stack pointer.

#### User State

The user state is the lower state of privilege. For instruction execution, the user state is determined by the  $S$  bit of the status register; if the  $S$  bit is negated (low), the processor is executing instructions in the user state.

Most instructions execute the same in user state as in the supervisor state. However, some instructions which have important system effects are made privileged. User programs are not permitted to execute the stop instruction or the reset instruction. To ensure that a user program cannot enter the supervisor state except in a controlled manner, the instructions which modify the whole state register are privileged. To aid in debugging programs which are to be used as operating systems, the move to user stack pointer (MOVE to USP) and move from user stack pointer (MOVE from USP) instructions are also privileged.

The bus cycles generated by an instruction executed in the user state are classified as user state references. This allows an external memory management device to translate the address and to control access to protected portions of the address space. While the processor is in the user privilege state, those instructions which use either the system stack pointer implicitly or address register seven explicitly, access the user stack pointer.

#### Privilege State Changes

Once the processor is in the user state and executing instructions, only exception processing can change the privilege state. During exception processing, the current setting of the  $S$  bit of the status register is saved and the  $S$  bit is asserted, putting the processor in the supervisor state. Therefore, when instruction execution resumes at the address specified to process the exception, the processor is in the supervisor privilege state.

# 16-/32-Bit Microprocessor

# SCN68000

**Table 18. Bus Cycle Classification**

FUNCTION CODE OUTPUT			REFERENCE CLASS
FC2	FC1	FC0	
0	0	0	(Unassigned)
0	0	1	User data
0	1	0	User program
0	1	1	(Unassigned)
1	0	0	(Unassigned)
1	0	1	Supervisor data
1	1	0	Supervisor program
1	1	1	Interrupt acknowledge

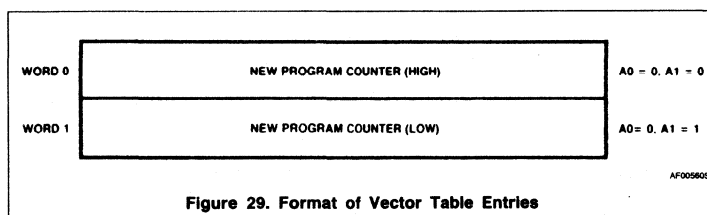

**Figure 29. Format of Vector Table Entries**

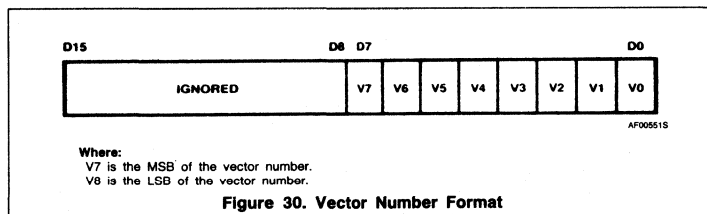

**Figure 30. Vector Number Format**

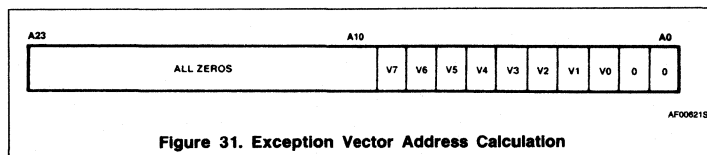

**Figure 31. Exception Vector Address Calculation**

### Reference Classification

When the processor makes a reference, it classifies the kind of reference being made, using the encoding on the three function code output lines. This allows external translation of addresses, control of access, and differentiation of special processor state, such as interrupt acknowledge. Table 18 lists the classification of references.

### Exception Processing

Before discussing the details of interrupts, traps, and tracing, a general description of exception processing is in order. The processing of an exception occurs in four steps, with variations for different exception causes. During the first step, a temporary copy of the status register is made and the status register is set for exception processing. In the second step the exception vector is determined and the third step is the saving of the current processor context. In the fourth step a new context is obtained and the processor switches to instruction processing.

### Exception Vectors

Exception vectors are memory locations from which the processor fetches the address of a routine which will handle that exception. All exception vectors are two words in length (Figure 29), except for the reset vector which is four words. All exception vectors lie in the supervisor data space, except for the reset vector which is in the supervisor program space. A vector number is an 8-bit number which, when multiplied by four, gives the address of an exception vector. Vector numbers are generated internally or externally, depending on the cause of the exception. In the case of interrupts, during the interrupt acknowledge bus cycle, a peripheral provides an 8-bit vector number (Figure 30) to the processor on data bus lines D0 through D7. The processor translates the vector number into a full 24-bit address, shown in Figure 31. The memory layout for exception vectors is given in Table 19.



## 16-/32-Bit Microprocessor

SCN68000

2

Table 19. Exception Vector Table

VECTOR NUMBER(S)	ADDRESS			ASSIGNMENT
	Dec	Hex	Space	
0	0	000	SP	Reset: initial SSP
-	4	004	SP	Reset: initial PC
2	8	008	SD	Bus error
3	12	00C	SD	Address error
4	16	010	SD	Illegal instruction
5	20	014	SD	Zero divide
6	24	018	SD	CHK instruction
7	28	01C	SD	TRAPV instruction
8	32	020	SD	Privilege violation
9	36	024	SD	Trace
10	40	028	SD	Line 1010 emulator
11	44	02C	SD	Line 1111 emulator
12*	48	030	SD	(Unassigned, reserved)
13*	52	034	SD	(Unassigned, reserved)
14*	56	038	SD	(Unassigned, reserved)
15	60	03C	SD	Uninitialized interrupt vector
16 - 23*	64	04C	SD	(Unassigned, reserved)
	95	05F		-
24	96	060	SD	Spurious interrupt
25	100	064	SD	Level 1 interrupt autovector
26	104	068	SD	Level 2 interrupt autovector
27	108	06C	SD	Level 3 interrupt autovector
28	112	070	SD	Level 4 interrupt autovector
29	116	074	SD	Level 5 interrupt autovector
30	120	078	SD	Level 6 interrupt autovector
31	124	07C	SD	Level 7 interrupt autovector
32 - 47	128	080	SD	TRAP instruction vectors
	191	0BF		-
48 - 63*	192	0C0	SD	(Unassigned, reserved)
	255	0FF		-
64 - 255	256	100	SD	User interrupt vectors
	1023	3FF		-

**NOTE:**

\*Vector numbers 12, 13, 14, 16 through 23, and 48 through 63 are reserved for future enhancements by Signetics. No user peripheral devices should be assigned these numbers.

As shown in Table 19, the memory layout is 512 words long (1024 bytes). It starts at address 0 and proceeds through address 1023. This provides 255 unique vectors; some of these are reserved for TRAPs and other system functions. Of the 255, there are 192 reserved for user interrupt vectors. However, there is no protection on the first 64 entries, so user interrupt vectors may overlap at the discretion of the systems designer.

**Kinds of Exceptions**

Exceptions can be generated by either internal or external causes. The externally generated exceptions are the interrupts and the bus error and reset requests. The interrupts are requests from peripheral devices for processor action while the bus error and reset inputs are used for access control and processor restart. The internally generated exceptions come from instructions, or from

address errors or tracing. The trap (TRAP), trap on overflow (TRAPV), check data register against upper bounds (CHK), and divide (DIV) instructions all can generate exceptions as part of their instruction execution. In addition, illegal instructions, word fetches from odd addresses, and privilege violations cause exceptions. Tracing behaves like a very high-priority internally-generated interrupt after each instruction execution.

**Exception Processing Sequence**

Exception processing occurs in four identifiable steps. In the first step, an internal copy is made of the status register. After the copy is made, the S bit is asserted, putting the processor into the supervisor privilege state. Also, the T bit is negated which will allow the exception handler to execute unhindered by tracing. For the reset and interrupt exceptions, the interrupt priority mask is also updated.

In the second step, the vector number of the exception is determined. For interrupts, the vector number is obtained by a processor fetch and classified as an interrupt acknowledge. For all other exceptions, internal logic provides the vector number. This vector number is then used to generate the address of the exception vector.

The third step is to save the current processor status, except for the reset exception. The current program counter value and the saved copy of the status register are stacked using the supervisor stack pointer as shown in Figure 32. The program counter value stacked usually points to the next unexecuted instruction; however, for bus error and address error, the value stacked for the program counter is unpredictable, and may be incremented from the address of the instruction which caused the error. Additional information defining the current context is stacked for the bus error and address error exceptions.

The last step is the same for all exceptions. The new program counter value is fetched from the exception vector. The processor then resumes instruction execution. The instruction at the address given in the exception vector is fetched, and normal instruction decoding and execution is started.

**Multiple Exceptions**

These paragraphs describe the processing which occurs when multiple exceptions arise simultaneously. Exceptions can be grouped according to their occurrence and priority. The group 0 exceptions are reset, bus error, and address error. These exceptions cause the instruction currently being executed to be aborted and the exception processing to commence within two clock cycles.

The group 1 exceptions are trace and interrupt, as well as the privilege violations and

## 16-/32-Bit Microprocessor

SCN68000

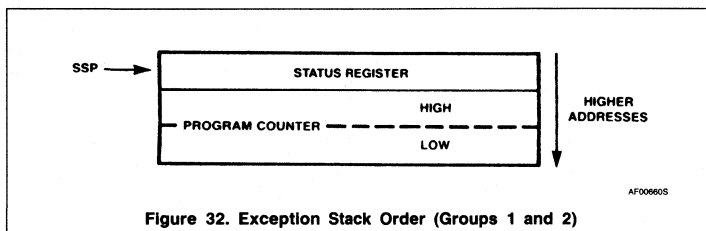

Figure 32. Exception Stack Order (Groups 1 and 2)

Table 20. Exception Grouping and Priority

GROUP	EXCEPTION	PROCESSING
0	Reset address error bus error	Exception processing begins within two clock cycles
1	Trace interrupt illegal privilege	Exception processing begins before the next instruction
2	TRAP, TRAPV, CHK, zero divide	Exception processing is started by normal instruction execution

illegal instructions. These exceptions allow the current instruction to execute to completion, but pre-empt the execution of the next instruction by forcing exception processing to occur (privilege violations and illegal instructions are detected when they are the next instruction to be executed). The group 2 exceptions occur as part of the normal processing of instructions. The TRAP, TRAPV, CHK, and zero divide exceptions are in this group. For these exceptions, the normal execution of an instruction may lead to exception processing.

Group 0 exceptions have highest priority, while group 2 exceptions have lowest priority. Within group 0, reset has highest priority, followed by bus error and then address error. Within group 1, trace has priority over external interrupts, which in turn takes priority over illegal instruction and privilege violation. Since only one instruction can be executed at a time, there is no priority relation within group 2.

The priority relation between two exceptions determines which is taken, or taken first, if the conditions for both arise simultaneously. Therefore, if a bus error occurs during a TRAP instruction, the bus error takes precedence, and the TRAP instruction processing is aborted. In another example, if an interrupt request occurs during the execution of an instruction while the T bit is asserted, the trace exception has priority, and is processed first. Before instruction processing resumes, however, the interrupt exception is also processed, and instruction processing commen-

ces finally in the interrupt handler routine. A summary of exception grouping and priority is given in Table 20.

### Exception Processing Detailed Discussion

Exceptions have a number of sources and each exception has processing which is peculiar to it. The following paragraphs detail the sources of exceptions, how each arises, and how each is processed.

#### Reset

The reset input provides the highest exception level. The processing of the reset signal is designed for system initiation and recovery from catastrophic failure. Any processing in progress at the time of the reset is aborted and cannot be recovered. The processor is forced into the supervisor state and the trace state is forced off. The processor interrupt priority mask is set at level seven. The vector number is internally generated to reference the reset exception vector at location 0 in the supervisor program space. Because no assumptions can be made about the validity of register contents, in particular the supervisor stack pointer, neither the program counter nor the status register is saved. The address contained in the first two words of the reset exception vector is fetched as the initial supervisor stack pointer, and the address in the last two words of the reset exception vector is fetched as the initial program counter. Finally, instruction execution is started at the address in the program counter. The power-up/restart code should be pointed to by the initial program counter.

The reset instruction does not cause loading of the reset vector, but does assert the reset line to reset external devices. This allows the software to reset the system to a known state and then continue processing with the next instruction.

#### Interrupts

Seven levels of interrupt priorities are provided. Devices may be chained externally within interrupt priority levels, allowing an unlimited number of peripheral devices to interrupt the processor. Interrupt priority levels are numbered from one to seven, with level seven being the highest priority. The status register contains a 3-bit mask which indicates the current processor priority, and interrupts are inhibited for all priority levels less than or equal to the current processor priority.

An interrupt request is made to the processor by encoding the interrupt request level on the interrupt request lines; a zero indicates no interrupt request. Interrupt requests arriving at the processor do not force immediate exception processing, but are made pending. Pending interrupts are detected between instruction executions. If the priority of the pending interrupt is lower than or equal to the current processor priority, execution continues with the next instruction and the interrupt exception processing is postponed. (The recognition of level seven is slightly different, as explained in the following paragraph.)

If the priority of the pending interrupt is greater than the current processor priority, the exception processing sequence is started. A copy of the status register is saved, the privilege state is sent to the supervisor stack, tracing is suppressed, and the processor priority level is set to the level of the interrupt acknowledged. The processor fetches the vector number from the interrupting device, classifying the reference as an interrupt acknowledge and displaying the level number of the interrupt being acknowledged on the address bus. If external logic requests an automatic vectoring, the processor internally generates a vector number which is determined by the interrupt level number. If external logic indicates a bus error, the interrupt is taken to be spurious, and the generated vector number references the spurious interrupt vector. The processor then proceeds with the usual exception processing, saving the program counter and status register on the supervisor stack. The saved value of the program counter is the address of the instruction which would have been executed had the interrupt not been present. The content of the interrupt vector whose vector number was previously obtained is fetched and loaded into the program counter, and normal instruction execution commences in the interrupt handling routine. A flowchart for the interrupt acknowledge sequence is given in Figure 33,

## 16-/32-Bit Microprocessor

SCN68000

a timing diagram is given in Figure 34, and the interrupt processing sequence is shown in Figure 35.

Priority level seven is a special case. Level seven interrupts cannot be inhibited by the interrupt priority mask, thus providing a "non-maskable interrupt" capability. An interrupt is generated each time the interrupt request level changes from some lower level to level seven. Note that a level seven interrupt may still be caused by the level comparison if the request level is a seven and the processor priority is set to a lower level by an instruction.

#### Uninitialized Interrupt

An interrupting device asserts  $\overline{VPA}$  or provides an interrupt during an interrupt acknowledge cycle to the SCN68000. If the vector register has not been initialized, the responding S68000 family peripheral will provide vector 15, the uninitialized interrupt vector. This provides a uniform way to recover from a programming error.

#### Spurious Interrupt

If during the interrupt acknowledge cycle no device responds by asserting  $\overline{DTACK}$  or  $\overline{VPA}$ ,

the bus error line should be asserted to terminate the vector acquisition. The processor separates the processing of this error from bus error by fetching the spurious interrupt vector instead of the bus error vector. The processor then proceeds with the usual exception processing.

#### Instruction Traps

Traps are exceptions caused by instructions. They arise either from processor recognition of abnormal conditions during instruction execution, or from use of instructions whose normal behavior is trapping.

Some instructions are used specifically to generate traps. The TRAP instruction always forces an exception and is useful for implementing system calls for user programs. The TRAPV and CHK instructions force an exception if the user program detects a runtime error, which may be an arithmetic overflow or a subscript out of bounds.

The signed divide (DIVS) and unsigned (DIVU) instructions will force an exception if a division operation is attempted with a divisor of zero.

#### Illegal and Unimplemented Instructions

"Illegal instruction" is the term used to refer to any of the word bit patterns which are not the bit pattern of the first word of a legal instruction. During instruction execution, if such an instruction is fetched, an illegal instruction exception occurs. Signetics reserves the right to define instructions whose opcodes may be any of the illegal instructions. Three bit patterns will always force an illegal instruction trap on all S68000 family compatible microprocessors. They are: \$4AFA, \$4AFB, and \$4AFC. Two of the patterns, \$4AFA and \$4AFB, are reserved for Signetics systems products. The third pattern, \$4AFC, is reserved for customer use.

Word patterns with bits 15 through 12 equaling 1010 or 1111 are distinguished as unimplemented instructions and separate exception vectors are given to these patterns to permit efficient emulation. This facility allows the operating system to detect program errors, or to emulate unimplemented instructions in software.

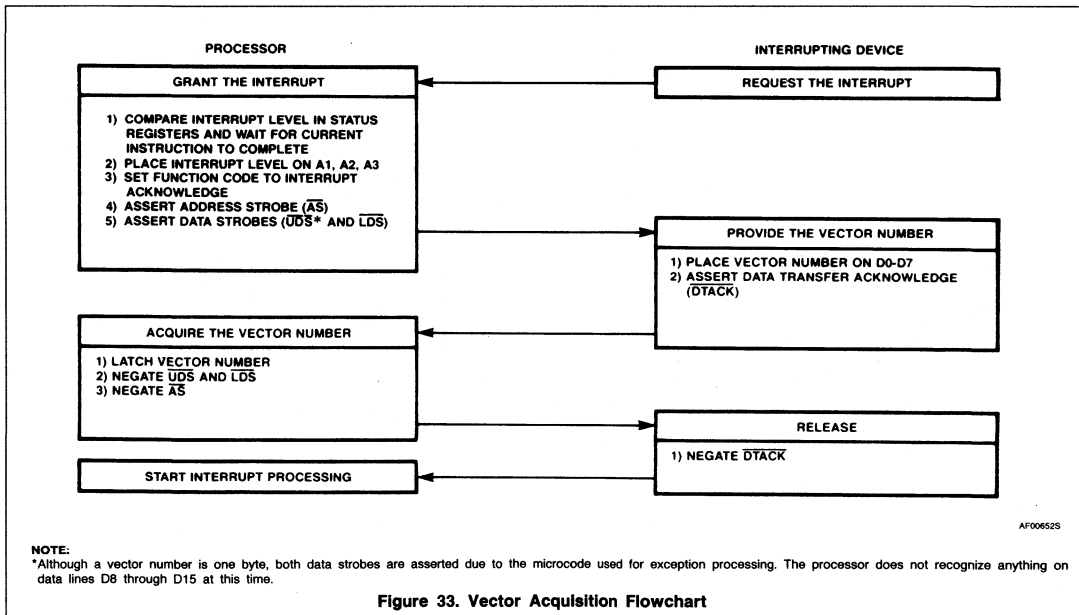

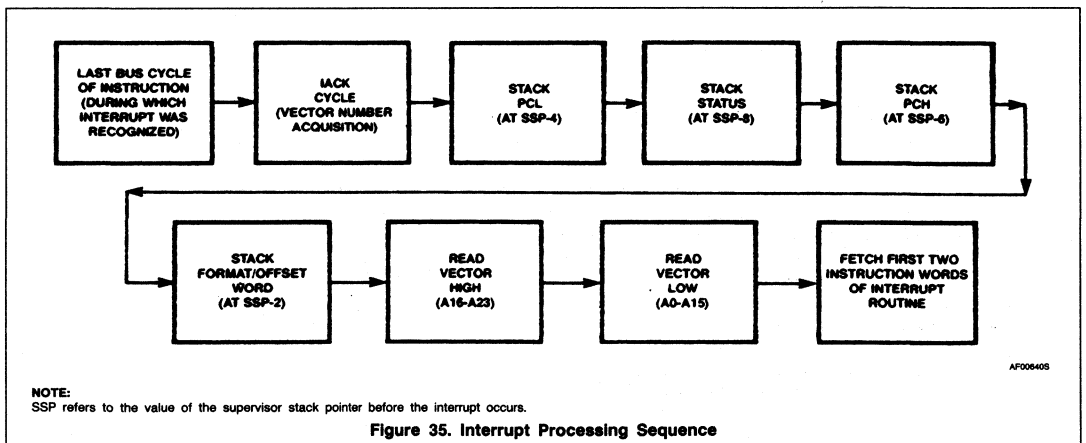
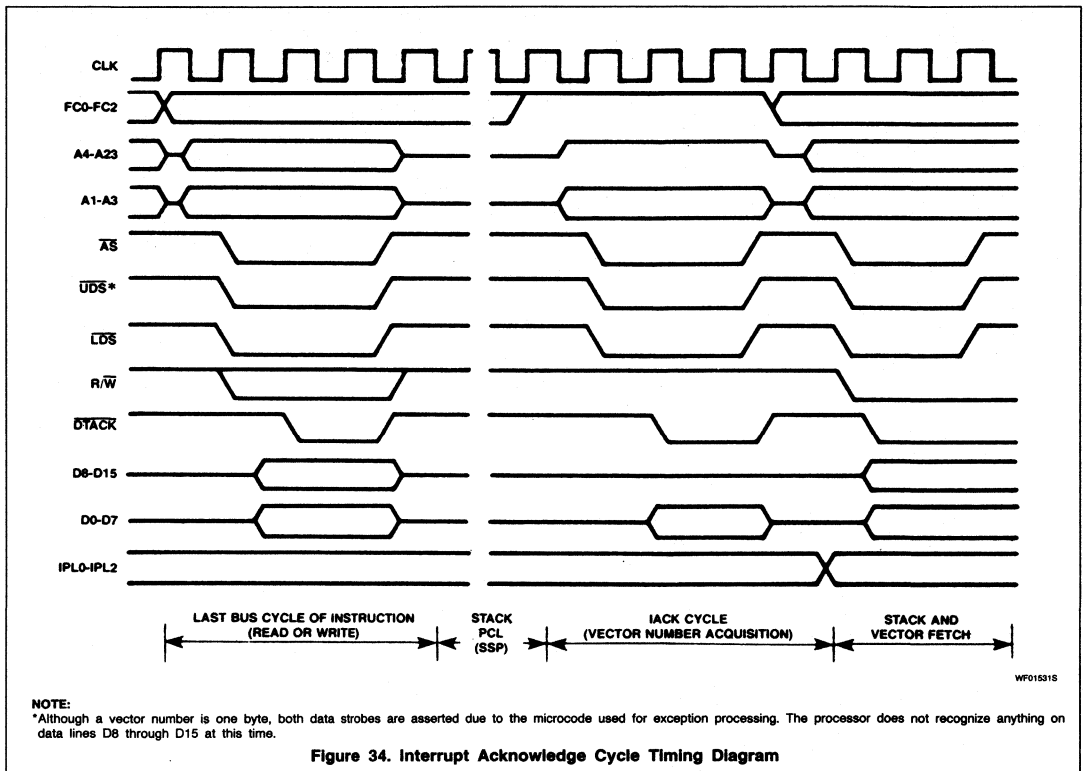

# 16-/32-Bit Microprocessor

# SCN68000

### Privilege Violations

In order to provide system security, various instructions are privileged. An attempt to execute one of the privileged instructions while in the user state will cause an exception. The privileged instructions are:

- STOP           AND Immediate to SR
- RESET         EOR Immediate to SR
- RTE           OR Immediate to SR
- MOVE to SR    MOVE to USP

### Tracing

To aid in program development, the SCN68000 includes a facility to allow instruction-by-instruction tracing. In the trace state, after each instruction is executed an exception is forced, allowing a debugging program to monitor the execution of the program under test.

The trace facility uses the T bit in the supervisor portion of the status register. If the T bit is negated (off), tracing is disabled, and instruction execution proceeds from instruction to instruction as normal. If the T bit is asserted (on) at the beginning of the execution of an instruction, a trace exception will be generated after the execution of that instruction is completed. If the instruction is not executed, either because an interrupt is taken, or the instruction is illegal or privileged, the trace exception does not occur. The trace exception also does not occur if the instruction is aborted by a reset, bus error, or address error exception. If the instruction is indeed executed and an interrupt is pending on completion, the trace exception is processed before the interrupt exception. If, during the execution of

the instruction an exception is forced by that instruction, the forced exception is processed before the trace exception.

As an extreme illustration of the above rules, consider the arrival of an interrupt during the execution of a TRAP instruction while tracing is enabled. First the trap exception is processed, then the trace exception, and finally the interrupt exception. Instruction execution resumes in the interrupt handler routine.

### Bus Error

Bus error exceptions occur when the external logic requests that a bus error be processed by an exception. The current bus cycle which the processor is making is then aborted. Whether the processor was doing instruction or exception processing, that processing is terminated, and the processor immediately begins exception processing.

Exception processing for the bus error follows the usual sequence of steps. The status register is copied, the supervisor state is entered, and the trace state is turned off. The vector number is generated to refer to the bus error vector. Since the processor was not between instructions when the bus error exception request was made, the context of the processor is more detailed. To save more of this context, additional information is saved on the supervisor stack. The program counter and the copy of the status register are of course saved. The value saved for the program counter is advanced by some amount, one to five words beyond the address of the first word of the instruction which made the reference causing the bus error. If the bus

error occurred during the fetch of the next instruction, the saved program counter has a value in the vicinity of the current instruction, even if the current instruction is a branch, a jump, or a return instruction. Besides the usual information, the processor saves its internal copy of the first word of the instruction being processed and the address which was being accessed by the aborted bus cycle. Specific information about the access is also saved: whether it was a read or a write, whether or not the processor was processing an instruction, and the classification displayed on the function code outputs when the bus error occurred. The processor is processing an instruction if it is in the normal state or processing a group 2 exception; the processor is not processing an instruction if it is processing a group 0 or a group 1 exception. Figure 36 illustrates how this information is organized on the supervisor stack. Although this information is not sufficient in general to effect full recovery from the bus error, it does allow software diagnosis. Finally, the processor commences instruction processing at the address contained in vector number two. It is the responsibility of the error handler routine to clean up the stack and determine where to continue execution.

If a bus error occurs during the exception processing for a bus error, address error, or reset, the processor is halted and all processing ceases. This simplifies the detection of catastrophic system failure, since the processor removes itself from the system rather than destroy any memory contents. Only the RESET pin can restart a halted processor.

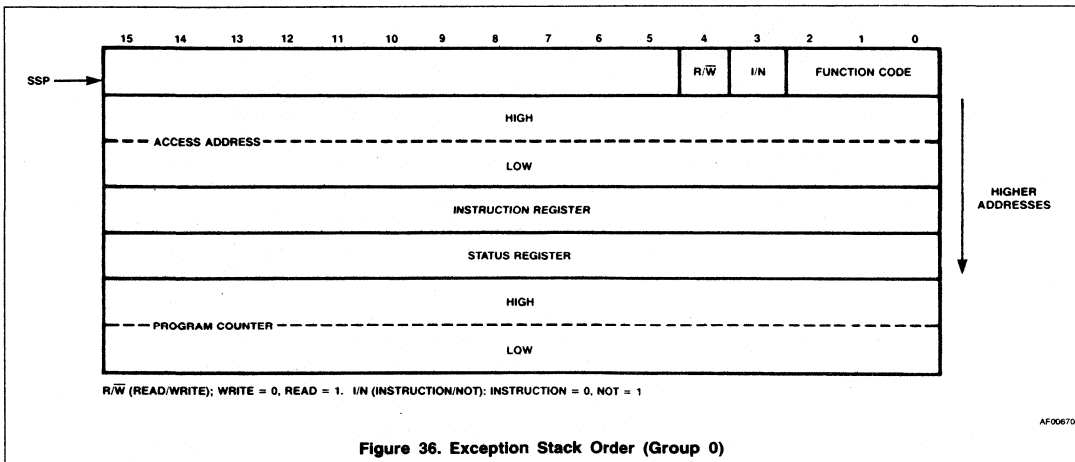

Figure 36. Exception Stack Order (Group 0)

# 16-/32-Bit Microprocessor

# SCN68000

### Address Error

Address error exceptions occur when the processor attempts to access a word or a long word operand or an instruction at an odd address. The effect is much like an internally generated bus error, so that the bus cycle is aborted and the processor ceases whatever processing it is currently doing and begins exception processing. After the exception processing commences, the sequence is the same as that for bus error including the

information that is stacked, except that the vector number refers to the address error vector instead. Likewise, if an address error occurs during the exception processing for a bus error, address error, or reset, the processor is halted. As shown in Figure 37, an address error will execute a short bus cycle followed by exception processing.

### INTERFACE WITH SYNCHRONOUS PERIPHERALS

To interface the synchronous peripherals with the asynchronous SCN68000, the processor modifies its bus cycle to meet the synchronous cycle requirements whenever a synchronous device address is detected. This is possible since both processors use memory mapped I/O. Figure 38 is a flowchart of the interface operation between the processor and synchronous devices.

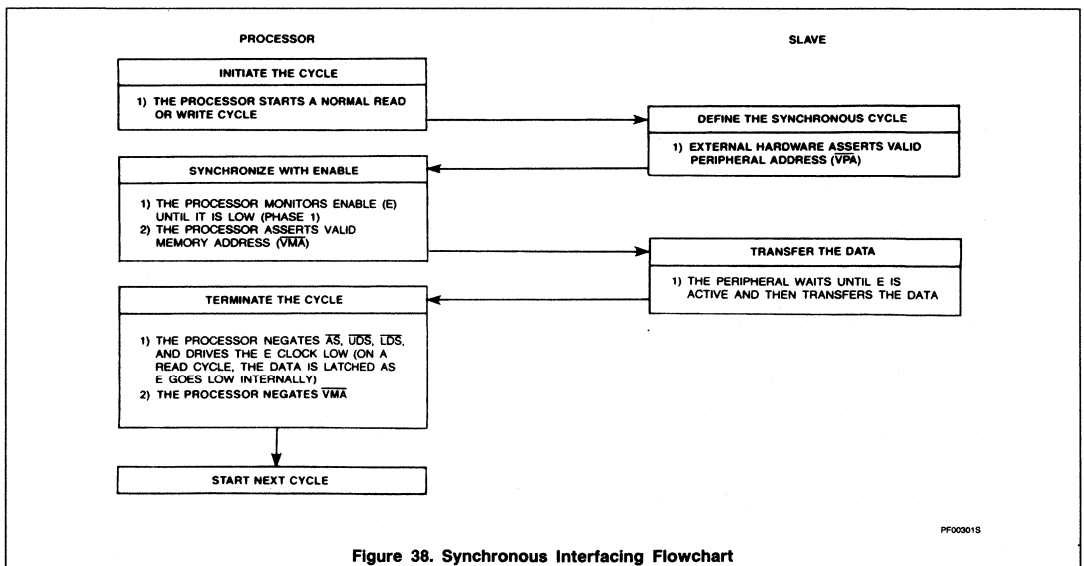
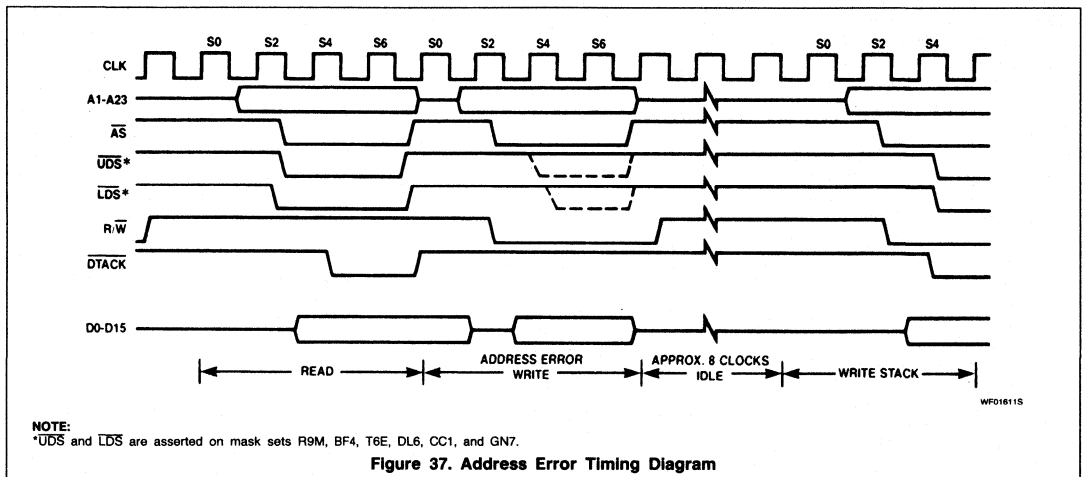

## 16-/32-Bit Microprocessor

SCN68000

## Data Transfer Operation

Three signals on the processor provide the synchronous interface. They are: enable (E), valid memory address ( $\overline{VMA}$ ), and valid peripheral address ( $\overline{VPA}$ ). Enable corresponds to the E or phase 2 signal in existing synchronous systems. The bus frequency is one tenth of the incoming SCN68000 clock frequency. The timing of E allows 1MHz peripherals to be used with 8MHz SCN68000s. Enable has a 60/40 duty cycle; that is, it is low for six input clocks and high for four input clocks. This duty cycle allows the processor to do successive  $\overline{VPA}$  accesses on successive E pulses.

Synchronous cycle timing is given in Figures 39, 40, 48, and 49. At state zero (S0) in the cycle, the address bus is in the high-impedance state. A function code is asserted on the function code output lines. One-half clock later, in state 1, the address bus is released from the high-impedance state.

During state 2, the address strobe ( $\overline{AS}$ ) is asserted to indicate that there is a valid address on the address bus. If the bus cycle is a read cycle, the upper and/or lower data strobes are also asserted in state 2. If the bus cycle is a write cycle, the read/write (R/ $\overline{W}$ ) signal is switched to low (write) during state 2. One-half clock later, in state 3, the write data is placed on the data bus, and in state 4 the data strobes are issued to indicate valid data on the data bus. The processor now inserts wait states until it recognizes the assertion of  $\overline{VPA}$ .

The  $\overline{VPA}$  input signals the processor that the address on the bus is the address of a synchronous device (or an area reserved for synchronous devices) and that the bus should conform to the phase 2 transfer characteristics of the synchronous bus. Valid peripheral address is derived by decoding the address bus, conditioned by the address strobe. Chip select for the synchronous peripherals should be derived by decoding the address bus conditioned by  $\overline{VMA}$ .

After recognition of  $\overline{VPA}$ , the processor assures that the enable (E) is low, by waiting if necessary, and subsequently asserts  $\overline{VMA}$ . Valid memory address is then used as part of the chip select equation of the peripheral. This ensures that the synchronous peripherals are selected and deselected at the correct time. The peripheral now runs its cycle during the high portion of the E signal. Figures 39 and 40 depict the best and worst case synchronous cycle timing. This cycle length is dependent strictly on when  $\overline{VPA}$  is asserted in relationship to the E clock.

If we assume that external circuitry asserts  $\overline{VPA}$  as soon as possible after the assertion

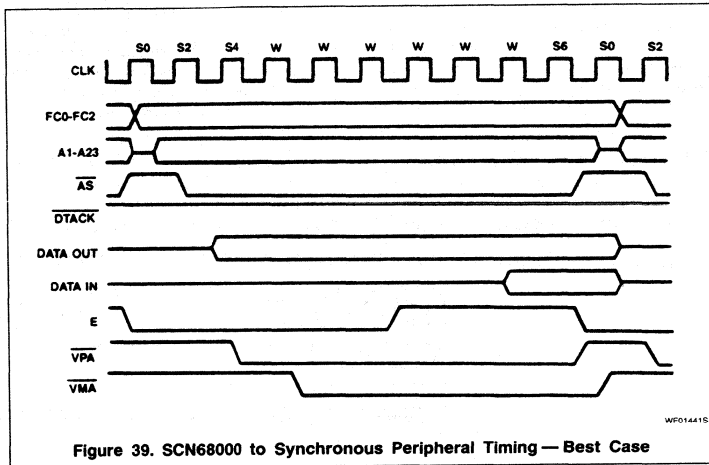

Figure 39. SCN68000 to Synchronous Peripheral Timing — Best Case

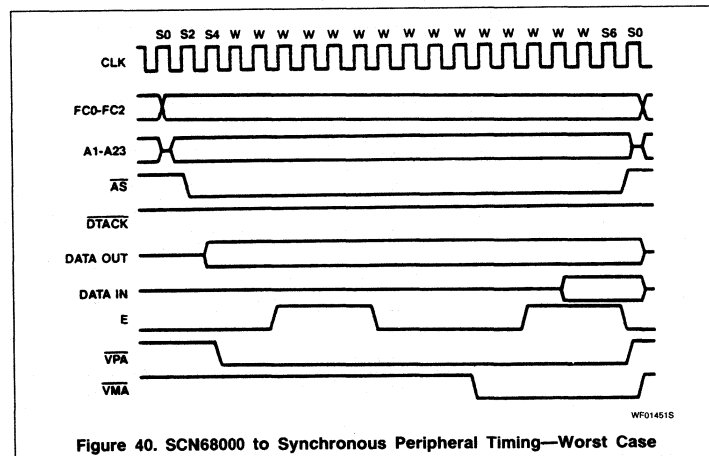

Figure 40. SCN68000 to Synchronous Peripheral Timing—Worst Case

of  $\overline{AS}$ , then  $\overline{VPA}$  will be recognized as being asserted on the falling edge of S4. In this case, no "extra" wait cycles will be inserted prior to the recognition of  $\overline{VPA}$  asserted and only the wait cycles inserted to synchronize with the E clock will determine the total length of the cycle. In any case, the synchronization delay will be some integral number of clock cycles within the following two extremes:

1. Best Case —  $\overline{VPA}$  is recognized as being asserted on the falling edge three clock cycles before E rises (or three clock cycles after E falls).
2. Worst Case —  $\overline{VPA}$  is recognized as being asserted on the falling edge two clock

cycles before E rises (or four clock cycles after E falls).

During a read cycle, the processor latches the peripheral data in state 6. For all cycles, the processor negates the address and data strobes one-half clock cycle later in state 7 and the enable signal goes low at this time. Another half clock later, the address bus is put in the high-impedance state. During a write cycle, the data bus is put in the high-impedance state and the read/write signal is switched high. The peripheral logic must remove  $\overline{VPA}$  within one clock after the address strobe is negated.

# 16-/32-Bit Microprocessor

# SCN68000

$\overline{DTACK}$  should not be asserted while  $\overline{VPA}$  is asserted. Notice that the SCN68000  $\overline{VMA}$  is active low, contrasted with the active high synchronous  $\overline{VMA}$ . This allows the processor to put its buses in the high-impedance state on DMA requests without inadvertently selecting the peripherals.

### Interrupt Interface Operation

During an interrupt acknowledge cycle while the processor is fetching the vector, the  $\overline{VPA}$  is asserted, the SCN68000 will assert  $\overline{VMA}$

and complete a normal synchronous read cycle as shown in Figure 41. The processor will then use an internally generated vector that is a function of the interrupt being serviced. This process is known as autovectoring. The seven autovectors are vector numbers 25 through 31 (decimal).

Autovectoring operates in the same fashion (but is not restricted to) the synchronous interrupt sequence. The basic difference is that there are six normal interrupt vectors and

one NMI type vector. As with both the synchronous and the SCN68000's normal vectored interrupt, the interrupt service routine can be located anywhere in the address space. This is due to the fact that while the vector numbers are fixed, the contents of the vector table entries are assigned by the user.

Since  $\overline{VMA}$  is asserted during autovectoring, care should be taken to insure the synchronous peripheral address decoding prevents unintended accesses.

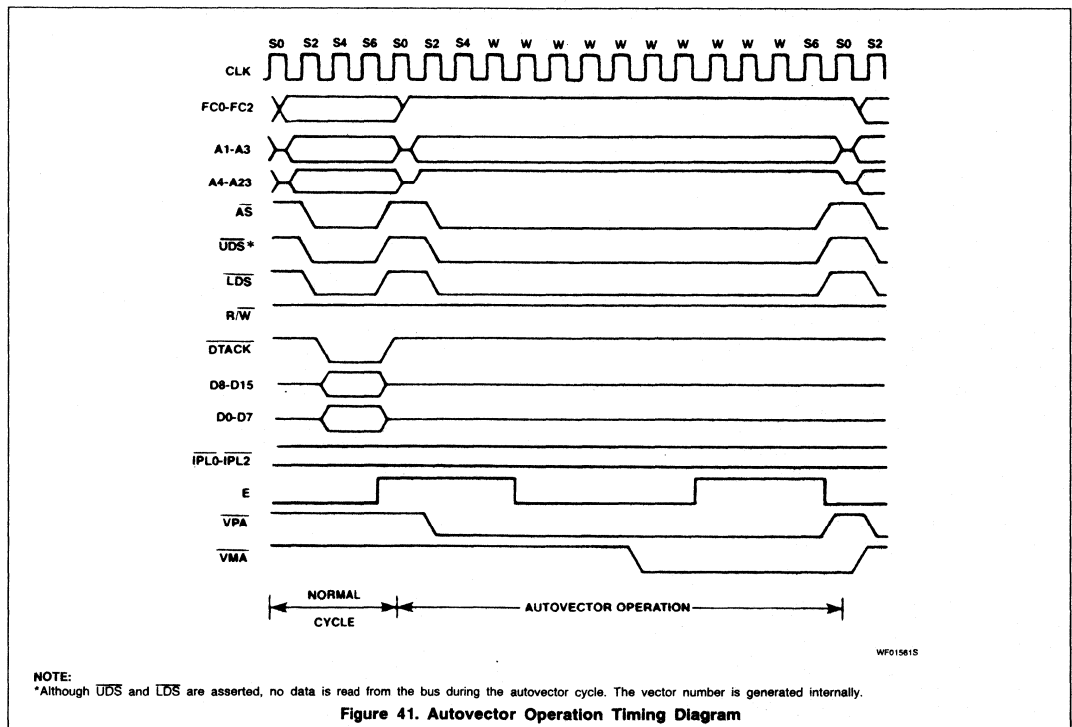



## 16-/32-Bit Microprocessor

SCN68000

**INSTRUCTION SET AND EXECUTION TIMES****Instruction Set**

The following paragraphs provide information about the addressing categories and instruction set of the SCN68000.

**Addressing Categories**

Effective address modes may be categorized by the ways in which they may be used. The following classifications will be used in the instruction definitions.

These categories may be combined, so that additional, more restrictive, classifications may be defined. For example, the instruction descriptions use such classifications as alterable memory or data alterable. The former refers to those addressing modes which are both alterable and memory addresses, and the latter refers to addressing modes which are both data and alterable.

Table 21 shows the various categories to which each of the effective address modes belong. Table 22 is the instruction set summary.

Data	If an effective address mode may be used to refer to data operands, it is considered a data addressing effective address mode.
Memory	If an effective address mode may be used to refer to memory operands, it is considered a memory addressing effective address mode.
Alterable	If an effective address mode may be used to refer to alterable (writable) operands, it is considered an alterable addressing effective address mode.
Control	If an effective address mode may be used to refer to memory operands without an associated size, it is considered a control addressing effective address mode.

**Table 21. Effective Addressing Mode Categories**

EFFECTIVE ADDRESS MODES	MODE	REGISTER	ADDRESSING CATEGORIES			
			Data	Memory	Control	Alterable
Dn	000	Register number	X	-	-	X
An	001	Register number	-	-	-	X
(An)	010	Register number	X	X	X	X
(An)+	011	Register number	X	X	-	X
-(An)	100	Register number	X	X	-	X
d(An)	101	Register number	X	X	X	X
d(An, ix)	110	Register number	X	X	X	X
xxx.W	111	000	X	X	X	X
xxx.L	111	001	X	X	X	X
d(PC)	111	010	X	X	X	-
d(PC, ix)	111	011	X	X	X	-
#xxx	111	100	X	X	-	-

## 16-/32-Bit Microprocessor

SCN68000

Table 22. Instruction Set

MNEMONIC	DESCRIPTION	OPERATION	CONDITION CODES				
			X	N	Z	V	C
ABCD	Add decimal with extend	$(\text{Destination})_{10} + (\text{Source})_{10} + X \rightarrow \text{Destination}$	*	U	*	U	*
ADD	Add binary	$(\text{Destination}) + (\text{Source}) \rightarrow \text{Destination}$	*	*	*	*	*
ADDA	Add address	$(\text{Destination}) + (\text{Source}) \rightarrow \text{Destination}$	-	-	-	-	-
ADDI	Add immediate	$(\text{Destination}) + \text{Immediate Data} \rightarrow \text{Destination}$	*	*	*	*	*
ADDQ	Add quick	$(\text{Destination}) + \text{Immediate Data} \rightarrow \text{Destination}$	*	*	*	*	*
ADDX	Add extended	$(\text{Destination}) + (\text{Source}) + X \rightarrow \text{Destination}$	*	*	*	*	*
AND	AND logical	$(\text{Destination}) \wedge (\text{Source}) \rightarrow \text{Destination}$	-	*	*	0	0
ANDI	AND immediate	$(\text{Destination}) \wedge \text{Immediate Data} \rightarrow \text{Destination}$	-	*	*	0	0
ANDI to CCR	AND immediate to condition codes	$(\text{Source}) \wedge \text{CCR} \rightarrow \text{CCR}$	*	*	*	*	*
ANDI to SR	AND immediate to status register	$(\text{Source}) \wedge \text{SR} \rightarrow \text{SR}$	*	*	*	*	*
ASL, ASR	Arithmetic shift	$(\text{Destination})$ Shifted by $\langle \text{count} \rangle \rightarrow \text{Destination}$	*	*	*	*	*
B <sub>CC</sub>	Branch conditionally	If $\text{CC}$ then $\text{PC} + d \rightarrow \text{PC}$	-	-	-	-	-
BCHG	Test a bit and change	$\sim(\langle \text{bit number} \rangle)$ OF Destination $\rightarrow Z$ $\sim(\langle \text{bit number} \rangle)$ OF Destination $\rightarrow$ $\langle \text{bit number} \rangle$ OF Destination	-	-	*	-	-
BCLR	Test a bit and clear	$\sim(\langle \text{bit number} \rangle)$ OF Destination $\rightarrow Z$ $0 \rightarrow \langle \text{bit number} \rangle \rightarrow$ OF Destination	-	-	*	-	-
BRA	Branch always	$\text{PC} + d \rightarrow \text{PC}$	-	-	-	-	-
BSET	Test a bit and set	$\sim(\langle \text{bit number} \rangle)$ OF Destination $\rightarrow Z$ $1 \rightarrow \langle \text{bit number} \rangle$ OF Destination	-	-	*	-	-
BSR	Branch to subroutine	$\text{PC} \rightarrow -(\text{SP}); \text{PC} + d \rightarrow \text{PC}$	-	-	-	-	-
BTST	Test a bit	$\sim(\langle \text{bit number} \rangle)$ OF Destination $\rightarrow Z$	-	-	*	-	-
CHK	Check register against bounds	If $\text{Dn} < 0$ or $\text{Dn} > (\langle \text{ea} \rangle)$ then TRAP	-	*	U	U	U
CLR	Clear an operand	$0 \rightarrow \text{Destination}$	-	0	1	0	0
CMP	Compare	$(\text{Destination}) - (\text{Source})$	-	*	*	*	*
CMPA	Compare address	$(\text{Destination}) - (\text{Source})$	-	*	*	*	*
CMPI	Compare immediate	$(\text{Destination}) - \text{Immediate Data}$	-	*	*	*	*
CMPM	Compare memory	$(\text{Destination}) - (\text{Source})$	-	*	*	*	*
DB <sub>CC</sub>	Test condition, decrement and branch	if $\sim \text{CC}$ then $\text{Dn} - 1 \rightarrow \text{Dn}$ ; if $\text{Dn} \neq -1$ then $\text{PC} + d \rightarrow \text{PC}$	-	-	-	-	-
DIVS	Signed divide	$(\text{Destination}) / (\text{Source}) \rightarrow \text{Destination}$	-	*	*	*	0
DIVU	Unsigned divide	$(\text{Destination}) / (\text{Source}) \rightarrow \text{Destination}$	-	*	*	*	0
EOR	Exclusive OR logical	$(\text{Destination}) \oplus (\text{Source}) \rightarrow \text{Destination}$	-	*	*	0	0
EORI	Exclusive OR immediate	$(\text{Destination}) \oplus \text{Immediate Data} \rightarrow \text{Destination}$	-	*	*	0	0
EORI to CCR	Exclusive OR immediate to condition codes	$(\text{Source}) \oplus \text{CCR} \rightarrow \text{CCR}$	*	*	*	*	*
EORI to SR	Exclusive OR immediate to status register	$(\text{Source}) \oplus \text{SR} \rightarrow \text{SR}$	*	*	*	*	*
EXG	Exchange register	$\text{Rx} \leftrightarrow \text{Ry}$	-	-	-	-	-
EXT	Sign extend	$(\text{Destination})$ Sign-extended $\rightarrow \text{Destination}$	-	*	*	0	0
JMP	Jump	Destination $\rightarrow \text{PC}$	-	-	-	-	-
JSR	Jump to subroutine	$\text{PC} \rightarrow -(\text{SP}); \text{Destination} \rightarrow \text{PC}$	-	-	-	-	-
LEA	Load effective address	Destination $\rightarrow \text{An}$	-	-	-	-	-
LINK	Link and allocate	$\text{An} \rightarrow -(\text{SP}); \text{SP} \rightarrow \text{An}; \text{SP} + \text{Displacement} \rightarrow \text{SP}$	-	-	-	-	-
LSL, LSR	Logical shift	$(\text{Destination})$ Shifted by $\langle \text{count} \rangle \rightarrow \text{Destination}$	*	*	*	0	*
MOVE	Move data from source to destination	$(\text{Source}) \rightarrow \text{Destination}$	-	*	*	0	0
MOVE to CCR	Move to condition code	$(\text{Source}) \rightarrow \text{CCR}$	*	*	*	*	*
MOVE to SR	Move to status register	$(\text{Source}) \rightarrow \text{SR}$	*	*	*	*	*
MOVE from SR	Move from status register	$\text{SR} \rightarrow \text{Destination}$	-	-	-	-	-

## 16-/32-Bit Microprocessor

SCN68000

2

Table 22. Instruction Set (Continued)

MNEMONIC	DESCRIPTION	OPERATION	CONDITION CODES				
			X	N	Z	V	C
MOVE USP	Move user stack pointer	USP → An; An → USP	-	-	-	-	-
MOVEA	Move address	(Source) → Destination	-	-	-	-	-
MOVEM	Move multiple registers	Registers → Destination (Source) → Registers	-	-	-	-	-
MOVEP	Move peripheral data	(Source) → Destination	-	-	-	-	-
MOVEQ	Move quick	Immediate Data → Destination	-	*	*	0	0
MULS	Signed multiply	(Destination) X (Source) → Destination	-	*	*	0	0
MULU	Unsigned multiply	(Destination) X (Source) → Destination	-	*	*	0	0
NBCD	Negate decimal with extend	0 - (Destination) <sub>10</sub> - X → Destination	*	U	*	U	*
NEG	Negate	0 - (Destination) → Destination	*	*	*	*	*
NEGX	Negate with extend	0 - (Destination) - X → Destination	*	*	*	*	*
NOP	No operation	-	-	-	-	-	-
NOT	Logical complement	~ (Destination) → Destination	-	*	*	0	0
OR	Inclusive OR logical	(Destination) v (Source) → Destination	-	*	*	0	0
ORI	Inclusive OR immediate	(Destination) v Immediate Data → Destination	-	*	*	0	0
ORI to CCR	Inclusive OR immediate to conditions codes	(Source) v CCR → CCR	*	*	*	*	*
ORI to SR	Inclusive OR immediate to status register	(Source) v SR → SR	*	*	*	*	*
PEA	Push effective address	Destination → -(SP)	-	-	-	-	-
RESET	Reset external devices	-	-	-	-	-	-
ROL, ROR	Rotate (without extend)	(Destination) Rotated by < count > → Destination	-	*	*	0	*
ROXL, ROXR	Rotate with extend	(Destination) Rotated by < count > → Destination	*	*	*	0	*
RTE	Return from exception	(SP) + → SR; (SP) + → PC	*	*	*	*	*
RTR	Return and restore condition codes	(SP) + → CC; (SP) + → PC	*	*	*	*	*
RTS	Return from subroutine	(SP) + → PC	-	-	-	-	-
SBCD	Subtract decimal with extend	(Destination) <sub>10</sub> - (Source) <sub>10</sub> - X → Destination	*	U	*	U	*
Scc	Set according to condition	If cc then 1's → Destination else 0's → Destination	-	-	-	-	-
STOP	Load status register and stop	Immediate Data → SR; STOP	*	*	*	*	*
SUB	Subtract binary	(Destination) - (Source) → Destination	*	*	*	*	*
SUBA	Subtract address	(Destination) - (Source) → Destination	-	-	-	-	-
SUBI	Subtract immediate	(Destination) - Immediate Data → Destination	*	*	*	*	*
SUBQ	Subtract quick	(Destination) - Immediate Data → Destination	*	*	*	*	*
SUBX	Subtract with extend	(Destination) - (Source) - X → Destination	*	*	*	*	*
SWAP	Swap register halves	Register [31:16] ↔ Register [15:0]	-	*	*	0	0
TAS	Test and set an operand	(Destination) Tested → CC; 1 → [7] OF Destination	-	*	*	0	0
TRAP	Trap	PC → -(SSP); SR → -(SSP); (Vector) → PC	-	-	-	-	-
TRAPV	Trap on overflow	If V then TRAP	-	-	-	-	-
TST	Test and operand	(Destination) Tested → CC	-	*	*	0	0
UNLK	Unlink	An → SP; (SP) + → An	-	-	-	-	-

## NOTES:

[ ] = bit number	* affected
⊕ logical exclusive OR	- unaffected
^ logical AND	0 cleared
v logical OR	1 set
~ logical complement	U undefined

## 16-/32-Bit Microprocessor

SCN68000

**Instruction Prefetch**

The SCN68000 uses a two-word tightly-coupled instruction prefetch mechanism to enhance performance. This mechanism is described in terms of the microcode operations involved. If the execution of an instruction is defined to begin when the microcode for that instruction is entered, some features of the prefetch mechanism can be described.

1. When execution of an instruction begins, the operation word and the word following have already been fetched. The operation word is in the instruction decoder.
2. In the case of multi-word instructions, as each additional word of the instruction is used internally, a fetch is made to the instruction stream to replace it.
3. The last fetch for an instruction from the instruction stream is made when the operation word is discarded and decoding is started on the next instruction.
4. If the instruction is a single-word instruction causing a branch, the second word is not used. But because this word is fetched by the preceding instruction, it is impossible to avoid this superfluous fetch.
5. In the case of an interrupt or trace exception, both words are not used.
6. The program counter usually points to the last word fetched from the instruction stream.

**Instruction Execution Times**

The following paragraphs contain listings of the instruction execution times in terms of external clock (CLK) periods. In this timing data, it is assumed that both memory read and write cycle times are four clock periods. Any wait states caused by a longer memory

**Table 23. Effective Address Calculation Times**

ADDRESSING MODE		BYTE,WORD	LONG
<b>Register</b>			
Dn	Data register direct	0(0/0)	0(0/0)
An	Address register direct	0(0/0)	0(0/0)
<b>Memory</b>			
(An)	Address register indirect	4(1/0)	8(2/0)
(An)+	Address register indirect with postincrement	4(1/0)	8(2/0)
-(An)	Address register indirect with predecrement	6(1/0)	10(2/0)
d(An)	Address register indirect with displacement	8(2/0)	12(3/0)
d(An,ix)*	Address register indirect with index	10(2/0)	14(3/0)
xxx.W	Absolute short	8(2/0)	12(3/0)
xxx.L	Absolute long	12(3/0)	16(4/0)
d(PC)	Program counter with displacement	8(2/0)	12(3/0)
d(PC,ix)*	Program counter with index	10(2/0)	14(3/0)
#xxx	Immediate	4(1/0)	8(2/0)

**NOTE:**

\*The size of the index register (ix) does not affect execution time.

cycle must be added to the total instruction time. The number of bus, read and write cycles for each instruction is also included with the timing data. This timing data is enclosed in parentheses following the execution periods and is shown as (r/w) where r is the number of read cycles and w is the number of write cycles.

**NOTE:**

The number of periods includes instruction fetch and all applicable operand fetches and stores.

**Effective Address Operand Calculation Timing**

Table 23 lists the number of clock periods required to compute an instruction's effective address. It includes fetching of any extension words, the address computation, and fetching of the memory operand. The number of bus read and write cycles is shown in parentheses as (r/w). Note there are no write cycles involved in processing the effective address.

**Move Instruction Execution Times**

Tables 24 and 25 indicate the number of clock periods for the move instruction. This data includes instruction fetch, operand reads, and operand writes. The number of bus read and write cycles is shown in parentheses as (r/w).

**Table 24. MOVE Byte Instruction Execution Times**

SOURCE	DESTINATION								
	Dn	An	(An)	(An)+	-(An)	d(An)	d(An,ix)*	xxx.W	xxx.L
Dn	4(1/0)	4(1/0)	8(1/1)	8(1/1)	8(1/1)	12(2/1)	14(2/1)	12(2/1)	16(3/1)
An	4(1/0)	4(1/0)	8(1/1)	8(1/1)	8(1/1)	12(2/1)	14(2/1)	12(2/1)	16(3/1)
(An)	8(2/0)	8(2/0)	12(2/1)	12(2/1)	12(2/1)	16(3/1)	18(3/1)	16(3/1)	20(4/1)
(An)+	8(2/0)	8(2/0)	12(2/1)	12(2/1)	12(2/1)	16(3/1)	18(3/1)	16(3/1)	20(4/1)
-(An)	10(2/0)	10(2/0)	14(2/1)	14(2/1)	14(2/1)	18(3/1)	20(3/1)	18(3/1)	22(4/1)
d(An)	12(3/0)	12(3/0)	16(3/1)	16(3/1)	16(3/1)	20(4/1)	22(4/1)	20(4/1)	24(5/1)
d(An,ix)*	14(3/0)	14(3/0)	18(3/1)	18(3/1)	18(3/1)	22(4/1)	24(4/1)	22(4/1)	26(5/1)
xxx.W	12(3/0)	12(3/0)	16(3/1)	16(3/1)	16(3/1)	20(4/1)	22(4/1)	20(4/1)	24(5/1)
xxx.L	16(4/0)	16(4/0)	20(4/1)	20(4/1)	20(4/1)	24(5/1)	26(5/1)	24(5/1)	28(6/1)
d(PC)	12(3/0)	12(3/0)	16(3/1)	16(3/1)	16(3/1)	20(4/1)	22(4/1)	20(4/1)	24(5/1)
d(PC,ix)*	14(3/0)	14(3/0)	18(3/1)	18(3/1)	18(3/1)	22(4/1)	24(4/1)	22(4/1)	26(5/1)
#xxx	8(2/0)	8(2/0)	12(2/1)	12(2/1)	12(2/1)	16(3/1)	18(3/1)	16(3/1)	20(4/1)

**NOTE:**

\*The size of the index register (ix) does not affect execution time.

## 16-/32-Bit Microprocessor

SCN68000

Table 25. MOVE LONG Instruction Execution Times

SOURCE	DESTINATION								
	Dn	An	(An)	(An)+	-(An)	d(An)	d(An,ix)*	xxx.W	xxx.L
Dn	4(1/0)	4(1/0)	12(1/2)	12(1/2)	12(1/2)	16(2/2)	18(2/2)	16(2/2)	20(3/2)
An	4(1/0)	4(1/0)	12(1/2)	12(1/2)	12(1/2)	16(2/2)	18(2/2)	16(2/2)	20(3/2)
(An)	12(3/0)	12(3/0)	20(3/2)	20(3/2)	20(3/2)	24(4/2)	26(4/2)	24(4/2)	28(5/2)
(An)+	12(3/0)	12(3/0)	20(3/2)	20(3/2)	20(3/2)	24(4/2)	26(4/2)	24(4/2)	28(5/2)
-(An)	14(3/0)	14(3/0)	22(3/2)	22(3/2)	22(3/2)	26(4/2)	28(4/2)	26(4/2)	30(5/2)
d(An)	16(4/0)	16(4/0)	24(4/2)	24(4/2)	24(4/2)	28(5/2)	30(5/2)	28(5/2)	32(6/2)
d(An,ix)*	18(4/0)	18(4/0)	26(4/2)	26(4/2)	26(4/2)	30(5/2)	32(5/2)	30(5/2)	34(6/2)
xxx.W	16(4/0)	16(4/0)	24(4/2)	24(4/2)	24(4/2)	28(5/2)	30(5/2)	28(5/2)	32(6/2)
xxx.L	20(5/0)	20(5/0)	28(5/2)	28(5/2)	28(5/2)	32(6/2)	34(6/2)	32(6/2)	36(7/2)
d(PC)	16(4/0)	16(4/0)	24(4/2)	24(4/2)	24(4/2)	28(5/2)	30(5/2)	28(5/2)	32(5/2)
d(PC,ix)*	18(4/0)	18(4/0)	26(4/2)	26(4/2)	26(4/2)	30(5/2)	32(5/2)	30(5/2)	34(6/2)
#xxx	12(3/0)	12(3/0)	20(3/2)	20(3/2)	20(3/2)	24(4/2)	26(4/2)	24(4/2)	28(5/2)

## NOTE:

\*The size of the index register (ix) does not affect execution time.

## Standard Instruction Execution Times

The number of clock periods shown in Table 26 indicates the time required to perform the operations, store the results, and read the next instruction. The number of bus read and write cycles is shown in parentheses as (r/w). The number of clock periods and the number of read and write cycles must be added respectively to those of the effective address calculation where indicated.

In Table 26 the headings have the following meanings: An = address register operand, DN = data register operand, ea = an operand specified by an effective address, and M = memory effective address operand.

Table 26. Standard Instruction Execution Times

INSTRUCTION	SIZE	op<ea>, An†	op<ea>, Dn	op Dn, <M>
ADD	byte, word	8(1/0)+	4(1/0)+	8(1/1)+
	long	6(1/0)+**	6(1/0)+**	12(1/2)+
AND	byte, word	-	4(1/0)+	8(1/1)+
	long	-	6(1/0)+**	12(1/2)+
CMP	byte, word	6(1/0)+	4(1/0)+	-
	long	6(1/0)+	6(1/0)+	-
DIVS	-	-	158(1/0)+*	-
DIVU	-	-	140(1/0)+*	-
EOR	byte, word	-	4(1/0)***	8(1/1)+
	long	-	8(1/0)***	12(1/2)+
MULS	-	-	70(1/0)+*	-
MULU	-	-	70(1/0)+*	-
OR	byte, word	-	4(1/0)+	8(1/1)+
	long	-	6(1/0)+**	12(1/2)+
SUB	byte, word	8(1/0)+	4(1/0)+	8(1/1)+
	long	6(1/0)+**	6(1/0)+**	12(1/2)+

## NOTES:

+ Add effective address calculation time.

† Word or long word only.

\* Indicates maximum value.

\*\* The base time of 6 clock periods is increased to 8 if the effective address mode is register direct or immediate (effective address time should also be added).

\*\*\* Only available effective address mode is data register direct.

DIVS, DIVU - The divide algorithm used by the SCN68000 provides less than 10% difference between the best and worst case timings.

MULS, MULU - The multiply algorithm requires  $38 + 2n$  clocks where  $n$  is defined as:MULU:  $n$  = the number of ones in the <ea>.MULS:  $n$  = concatenate the <ea> with a zero as the LSB;  $n$  is the resultant number of 10 or 01 patterns in the 17-bit source; i.e., worst case happens when the source is \$5555.

## 16-/32-Bit Microprocessor

SCN68000

**Immediate Instruction Execution Times**

The number of clock periods shown in Table 27 includes the time to fetch immediate operands, perform the operations, store the results, and read the next operation. The number of bus read and write cycles is shown in parentheses as (r/w). The number of clock periods and the number of read and write cycles must be added respectively to those of the effective address calculation where indicated.

In Table 27, the headings have the following meanings: # = immediate operand, DN = data register operand, An = address register operand, M = memory operand, and SR = status register.

**Table 27. Immediate Instruction Execution Times**

INSTRUCTION	SIZE	op #, Dn	op #, An	op #, M
ADDI	byte, word	8(2/0)	–	12(2/1)+
	long	16(3/0)	–	20(3/2)+
ADDQ	byte, word	4(1/0)	8(1/0)*	8(1/1)+
	long	8(1/0)	8(1/0)	12(1/2)+
ANDI	byte, word	8(2/0)	–	12(2/1)+
	long	16(3/0)	–	20(3/1)+
CMPI	byte, word	8(2/0)	–	8(2/0)+
	long	14(3/0)	–	12(3/0)+
EORI	byte, word	8(2/0)	–	12(2/1)+
	long	16(3/0)	–	20(3/2)+
MOVEQ	long	4(1/0)	–	–
ORI	byte, word	8(2/0)	–	12(2/1)+
	long	16(3/0)	–	20(3/2)+
SUBI	byte, word	8(2/0)	–	12(2/1)+
	long	16(3/0)	–	20(3/2)+
SUBQ	byte, word	4(1/0)	8(1/0)*	8(1/1)+
	long	8(1/0)	8(1/0)	12(1/2)+

**NOTES:**

+ Add effective address calculation time

\* Word only

**Single Operand Instruction Execution Times**

Table 28 indicates the number of clock periods for the single operand instructions. The number of bus read and write cycles is shown in parentheses as (r/w). The number of clock periods and the number of read and write cycles must be added respectively to those of the effective address calculation where indicated.

**Table 28. Single Operand Instruction Execution Times**

INSTRUCTION	SIZE	REGISTER	MEMORY
CLR	byte, word	4(1/0)	8(1/1)+
	long	6(1/0)	12(1/2)+
NBCD	byte	6(1/0)	8(1/1)+
NEG	byte, word	4(1/0)	8(1/1)+
	long	6(1/0)	12(1/2)+
NEGX	byte, word	4(1/0)	8(1/1)+
	long	6(1/0)	12(1/2)+
NOT	byte, word	4(1/0)	8(1/1)+
	long	6(1/0)	12(1/2)+
S <sub>CC</sub>	byte, false	4(1/0)	8(1/1)+
	byte, true	6(1/0)	8(1/1)+
TAS	byte	4(1/0)	10(1/1)
TST	byte, word	4(1/0)	4(1/0)+
	long	4(1/0)	4(1/0)+

**NOTE:**

+ Add effective address calculation time

## 16-/32-Bit Microprocessor

SCN68000

**Shift/Rotate Instruction Execution Times**

Table 29 indicates the number of clock periods for the shift and rotate instructions. The number of bus read and write cycles is shown in parentheses as (r/w). The number of clock periods and the number of read and write cycles must be added respectively to those of the effective address calculation where indicated.

**Table 29. Shift/Rotate Instruction Execution Times**

INSTRUCTION	SIZE	REGISTER	MEMORY
ASR, ASL	byte, word	$6 + 2n(1/0)$	$8(1/1)+$
	long	$8 + 2n(1/0)$	—
LSR, LSL	byte, word	$6 + 2n(1/0)$	$8(1/1)+$
	long	$8 + 2n(1/0)$	—
ROR, ROL	byte, word	$6 + 2n(1/0)$	$8(1/1)+$
	long	$8 + 2n(1/0)$	—
ROXR, ROXL	byte, word	$6 + 2n(1/0)$	$8(1/1)+$
	long	$8 + 2n(1/0)$	—

**NOTES:**

+ Add effective address calculation time  
n is the shift or rotate count

**Bit Manipulation Instruction Execution Times**

Table 30 indicates the number of clock periods required for the bit manipulation instructions. The number of bus read and write cycles is shown in parentheses as (r/w). The number of clock periods and the number of read and write cycles must be added respectively to those of the effective address calculation where indicated.

**Table 30. Bit Manipulation Instruction Execution Times**

INSTRUCTION	SIZE	DYNAMIC		STATIC	
		Register	Memory	Register	Memory
BCHG	byte	—	$8(1/1)+$	—	$12(2/1)+$
	long	$8(1/0)^*$	—	$12(2/0)^*$	—
BCLR	byte	—	$8(1/1)+$	—	$12(2/1)+$
	long	$10(1/0)^*$	—	$14(2/0)^*$	—
BSET	byte	—	$8(1/1)+$	—	$12(2/1)+$
	long	$8(1/0)^*$	—	$12(2/0)^*$	—
BTST	byte	—	$4(1/0)+$	—	$8(2/0)+$
	long	$6(1/0)$	—	$10(2/0)$	—

**NOTES:**

+ Add effective calculation time  
\* Indicates maximum value

**Conditional Instruction Execution Times**

Table 31 indicates the number of clock periods required for the conditional instructions. The number of bus read and write cycles is indicated in parentheses as (r/w). The number of clock periods and the number of read and write cycles must be added respectively to those of the effective address calculation where indicated.

**Table 31. Conditional Instruction Execution Times**

INSTRUCTION	DISPLACEMENT	BRANCH TAKEN	BRANCH NOT TAKEN
B <sub>CC</sub>	byte	$10(2/0)$	$8(1/0)$
	word	$10(2/0)$	$12(2/0)$
BRA	byte	$10(2/0)$	—
	word	$10(2/0)$	—
BSR	byte	$18(2/2)$	—
	word	$18(2/2)$	—
DB <sub>CC</sub>	CC true	—	$12(2/0)$
	CC false	$10(2/0)$	$14(3/0)$

## 16-/32-Bit Microprocessor

SCN68000

Table 32. JMP, JSR, LEA, PEA, and MOVEM Instruction Execution Times

INSTRUCTION	SIZE	(An)	(An)+	-(An)	d(An)	d(An, ix)+	xxx.W	xxx.L	d(PC)	d(PC,ix)*
JMP	-	8(2/0)	-	-	10(2/0)	14(3/0)	10(2/0)	12(3/0)	10(2/0)	14(3/0)
JSR	-	16(2/2)	-	-	18(2/2)	22(2/2)	18(2/2)	20(3/2)	18(2/2)	22(2/2)
LEA	-	4(1/0)	-	-	8(2/0)	12(2/0)	8(2/0)	12(3/0)	8(2/0)	12(2/0)
PEA	-	12(1/2)	-	-	16(2/2)	20(2/2)	16(2/2)	20(3/2)	16(2/2)	20(2/2)
MOVEM M → R	word	12 + 4n (3 + n/0)	12 + 4n (3 + n/0)	-	16 + 4n (4 + n/0)	18 + 4n (4 + n/0)	16 + 4n (4 + n/0)	20 + 4n (5 + n/0)	16 + 4n (4 + n/0)	18 + 4n (4 + n/0)
	long	12 + 8n (3 + 2n/0)	12 + 8n (3 + 2n/0)	-	16 + 8n (4 + 2n/0)	18 + 8n (4 + 2n/0)	16 + 8n (4 + 2n/0)	20 + 8n (5 + 2n/0)	16 + 8n (4 + 2n/0)	18 + 8n (4 + 2n/0)
MOVEM R → M	word	8 + 4n (2/n)	-	8 + 4n (2/n)	12 + 4n (3/n)	14 + 4n (3/n)	12 + 4n (3/n)	16 + 4n (4/n)	-	-
	long	8 + 8n (2/2n)	-	8 + 8n (2/2n)	12 + 8n (3/2n)	14 + 8n (3/2n)	12 + 8n (3/2n)	16 + 8n (4/2n)	-	-

## NOTES:

n is the number of registers to move

\* is the size of the index register (ix) and does not affect the instruction's execution time

## JMP, JSR, LEA, PEA, and MOVEM Instruction Execution Times

Table 32 indicates the number of clock periods required for the jump, jump-to-subroutine, load effective address, push effective address, and move multiple registers instructions. The number of bus read and write cycles is shown in parentheses as (r/w).

## Multi-Precision Instruction Execution Times

Table 33 indicates the number of clock periods for the multi-precision instructions. The number of clock periods includes the time to fetch both operands, perform the operations, store the results, and read the next instructions. The number of read and write cycles is shown in parentheses as (r/w).

In Table 33, the headings have the following meanings: Dn = data register operand and M = memory operand.

Table 33. Multi-Precision Instruction Execution Times

INSTRUCTION	SIZE	op Dn, Dn	op M, M
ADDX	byte, word	4(1/0)	18(3/1)
	long	8(1/0)	30(5/2)
CMPM	byte, word	-	12(3/0)
	long	-	20(5/0)
SUBX	byte, word	4(1/0)	18(3/1)
	long	8(1/0)	30(5/2)
ABCD	byte	6(1/0)	18(3/1)
SBCD	byte	6(1/0)	18(3/1)



## 16-/32-Bit Microprocessor

SCN68000

**Table 34. Miscellaneous Instruction Execution Times**

INSTRUCTION	SIZE	REGISTER	MEMORY
ANDI to CCR	byte	20(3/0)	-
ANDI to SR	word	20(3/0)	-
CHK	-	10(1/0)+	-
EORI to CCR	byte	20(3/0)	-
EORI to SR	word	20(3/0)	-
ORI to CCR	byte	20(3/0)	-
ORI to SR	word	20(3/0)	-
MOVE from SR	-	6(1/0)	8(1/1)+
MOVE to CCR	-	12(2/0)	12(2/0)+
MOVE to SR	-	12(2/0)	12(2/0)+
EXG	-	6(1/0)	-
EXT	word	4(1/0)	-
	long	4(1/0)	-
LINK	-	16(2/2)	-
MOVE from USP	-	4(1/0)	-
MOVE to USP	-	4(1/0)	-
NOP	-	4(1/0)	-
RESET	-	132(1/0)	-
RTE	-	20(5/0)	-
RTR	-	20(5/0)	-
RTS	-	16(4/0)	-
STOP	-	4(0/0)	-
SWAP	-	4(1/0)	-
TRAPV	-	4(1/0)	-
UNLK	-	12(3/0)	-

**NOTE:**

+ Add effective address calculation time

**Table 35. MOVE PERIPHERAL Instruction Execution Times**

INSTRUCTION	SIZE	REGISTER → MEMORY	MEMORY → REGISTER
MOVEP	word	16(2/2)	16(4/0)
	long	24(2/4)	24(6/0)

**Table 36. Exception Processing Execution Times**

EXCEPTION	PERIODS
Address error	50(4/7)
Bus error	50(4/7)
CHK instruction	44(5/4)+
Divide by zero	42(5/4)
Illegal instruction	34(4/3)
Interrupt	44(5/3)*
Privilege violation	34(4/3)
RESET**	40(6/0)
Trace	34(4/3)
TRAP instruction	38(4/4)
TRAPV instruction	34(4/3)

**NOTES:**

+ Add effective address calculation time.

\*The interrupt acknowledge cycle is assumed to take four clock periods.

\*\*Indicates the time from when RESET and HALT are first sampled as negated to when instruction execution starts.

**Miscellaneous Instruction Execution Times**

Tables 34 and 35 indicate the number of clock periods for the following miscellaneous instructions. The number of bus read and write cycles is shown in parentheses as (r/w). The number of clock periods plus the number of read and write cycles must be added to those of the effective address calculation where indicated.

**Exception Processing Execution Times**

Table 36 indicates the number of clock periods for exception processing. The number of clock periods includes the time for all stacking, the vector fetch, and the fetch of the first two instruction words of the handler routine. The number of bus read and write cycles is shown in parentheses as (r/w).

**ABSOLUTE MAXIMUM RATINGS**

SYMBOL	RATING	VALUE	UNIT
V <sub>CC</sub>	Supply voltage range	-0.3 to +7.0	V
V <sub>IN</sub>	Input voltage range	-0.3 to +7.0	V
T <sub>A</sub>	Operating temperature range SCN68000 SCN68000 ceramic	T <sub>L</sub> to T <sub>H</sub> 0 to 70 -40 to 85	°C
T <sub>TSG</sub>	Storage temperature range	-55 to 150	°C

**NOTE:**

This device contains circuitry to protect the inputs against damage due to high static voltages or electric fields; however, it is advised that normal precautions be taken to avoid application of any voltage higher than maximum-rated voltages to this high-impedance circuit. Reliability of operation is enhanced if unused inputs are tied to an appropriate logic voltage level (e.g., either GND or V<sub>CC</sub>).

**THERMAL CHARACTERISTICS**

CHARACTERISTIC	SYMBOL	VALUE	SYMBOL	VALUE	RATING
Thermal Resistance (Still Air)	θ <sub>JA</sub>	30	θ <sub>JC</sub>	15*	°C/W
		33		15	
		30		15*	

**NOTE:**

\*Estimated

# 16-/32-Bit Microprocessor

# SCN68000

## DC ELECTRICAL CHARACTERISTICS $V_{CC} = 5V_{DC} \pm 5\%$ ; $GND = 0V_{DC}$ ; $T_A = T_L$ to $T_H$ (see Figures 42, 43, and 44)

SYMBOL	CHARACTERISTIC	SYMBOL	MIN	MAX
$V_{IH}$	Input high voltage	2	$V_{CC}$	V
$V_{IL}$	Input low voltage	$GND - 0.3$	0.8	V
$I_{IN}$	Input leakage current @ 5.25V CLK, $\overline{IPL0}$ - $\overline{IPL2}$ , $\overline{VPA}$	BERR, BGACK, BR, DTACK, HALT, RESET	2.5 -	$\mu A$ 20
$I_{TSI}$	3-State (off state) input current @ 2.4V/0.4V	$\overline{AS}$ , A1-A23, D0-D15, FC0-FC2, $\overline{LDS}$ , R/W, $\overline{UDS}$ , $\overline{VMA}$	-	20 $\mu A$
$V_{OH}$	Output high voltage ( $I_{OH} = -400\mu A$ ) FC0-FC2, $\overline{LDS}$ , R/W, $\overline{UDS}$ , $\overline{VMA}$	E*, E, $\overline{AS}$ , A1-A23, $\overline{BG}$ , D0-D15, 2,4	$V_{CC} - 0.75$ -	V
$V_{OL}$	Output low voltage ( $I_{OL} = 1.6mA$ ) ( $I_{OL} = 3.2mA$ ) ( $I_{OL} = 5.0mA$ ) ( $I_{OL} = 5.3mA$ )	HALT A1-A23, $\overline{BG}$ , FC0-FC2 RESET E, $\overline{AS}$ , D0-D15, $\overline{LDS}$ , R/W $\overline{UDS}$ , $\overline{VMA}$	- - - -	0.5 0.5 0.5 0.5 V
$P_D^{***}$	Power dissipation (See Power Considerations)	-	-	W
$C_{IN}$	Capacitance ( $V_{IN} = 0V$ , $T_A = 25^\circ C$ ; frequency = 1MHz**)	-	20	pF

**NOTES:**

\* With external pullup resistor of 1.1k $\Omega$ .

\*\* Capacitance is periodically sampled rather than 100% tested.

\*\*\* During normal operation instantaneous  $V_{CC}$  current requirements may be as high as 1.5A.

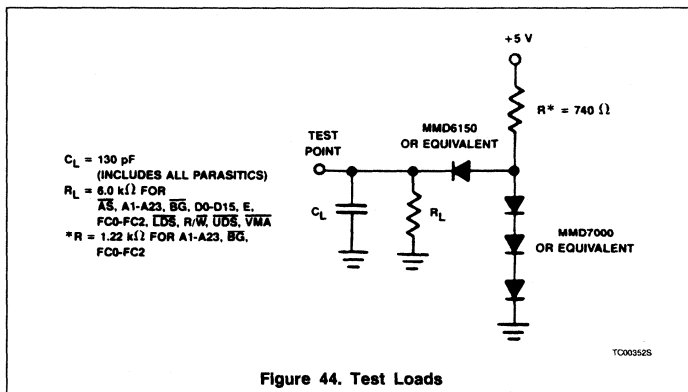
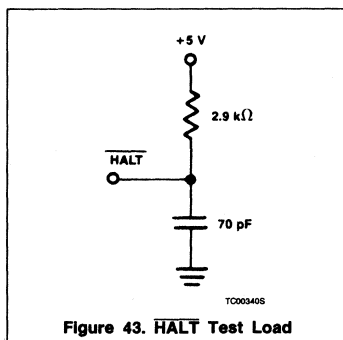
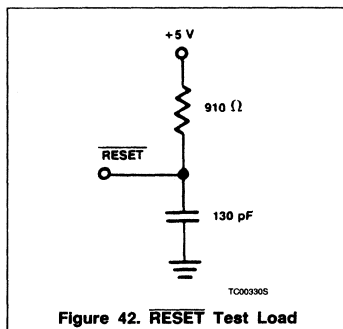

### Power Considerations

The average chip-junction temperature,  $T_J$ , in  $^\circ C$  can be obtained from:

$$T_J = T_A + (P_D \cdot \theta_{JA}) \quad (1)$$

Where:

$T_A$  = ambient temperature,  $^\circ C$

$\theta_{JA}$  = package thermal resistance, junction-to-ambient,  $^\circ C/W$

$P_D = P_{INT} + P_{I/O}$

$P_{INT} = I_{CC} \times V_{CC}$ , watts - chip internal power

$P_{I/O}$  = power dissipation on input and output pins - user determined

For most applications  $P_{I/O} < P_{INT}$  and can be neglected.

An approximate relationship between  $P_D$  and  $T_J$  (if  $P_{I/O}$  is neglected) is:

$$P_D = K \div (T_J + 273^\circ C) \quad (2)$$

Solving equations 1 and 2 for K gives:

$$K = T_D \cdot (T_A + 273^\circ C) + \theta_{JA} \cdot P_D^2 \quad (3)$$

Where K is a constant pertaining to the particular part. K can be determined from equation 3 by measuring  $P_D$  (at equilibrium) for a known  $T_A$ . Using this value of K the values of  $P_D$  and  $T_J$  can be obtained by solving equations (1) and (2) iteratively for any value of  $T_A$ .

Figure 45 illustrates the graphic solution to the equations, given above, for the specification power dissipations of 1.50 and 1.75 watts over the ambient temperature range of  $-55^\circ C$  to  $125^\circ C$  using an average  $\theta_{JA}$  of  $40^\circ C/watt$  to represent various SCN68000 packages.

# 16-/32-Bit Microprocessor

# SCN68000

However, actual  $\theta_{JA}$ 's in the range of 30°C to 50°C/watt only change the curves slightly.

The total thermal resistance of a package ( $\theta_{JA}$ ) can be separated into two components,  $\theta_{JC}$  and  $\theta_{CA}$ , representing the barrier to heat flow from the semiconductor junction to the package (case) surface ( $\theta_{JC}$ ) and from the case to the outside ambient ( $\theta_{CA}$ ). These terms are related by the equation:

$$\theta_{JA} = \theta_{JC} + \theta_{CA} \quad (4)$$

$\theta_{JC}$  is device related and cannot be influenced by the user. However,  $\theta_{CA}$  is user dependent and can be minimized by such thermal management techniques as heat sinks, ambient air cooling and thermal convection. Thus, good thermal management on the part of the user can significantly reduce  $\theta_{CA}$  so that  $\theta_{JA}$  approximately equals  $\theta_{JC}$ . Substitution of  $\theta_{JC}$  for  $\theta_{JA}$  in equation (1) will result in a lower semiconductor junction temperature.

Values for thermal resistance presented in this data sheet are provided for design purposes only. Thermal measurements are complex and dependent on procedure and setup. User derived values for thermal resistance may differ.

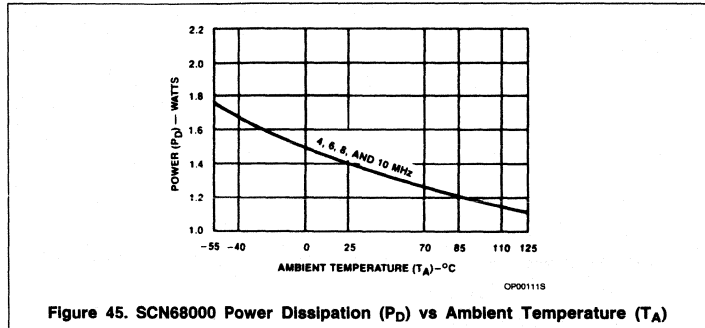

Figure 45. SCN68000 Power Dissipation ( $P_D$ ) vs Ambient Temperature ( $T_A$ )

### AC ELECTRICAL CHARACTERISTICS — Clock Timing (see Figure 46)

SYMBOL	CHARACTERISTIC	8MHz		10MHz		12.5MHz		UNIT
		Min	Max	Min	Max	Min	Max	
f	Frequency of operation	4	8	4	10	4	12.5	MHz
$t_{cyc}$	Cycle time	125	250	100	250	80	250	ns
$t_{CL}$ $t_{CH}$	Clock pulse width	55	125	45	125	35	125	ns
$t_{Cr}$ $t_{Cf}$	Rise and fall times	—	10	—	10	—	5	ns

Table 37. Maximum Power Dissipation by Package Type Modes

PACKAGE TYPE	TEMPERATURE (°C)	MAXIMUM POWER DISSIPATION (WATTS) PER FREQUENCY (MHz)		
		8MHz	10MHz	12.5MHz
Ceramic	0 to 70	1.50	1.50	1.75
	-40 to 85	1.65	1.65	—
Plastic	0 to 70	1.50	1.50	—
	-40 to 85	1.65	1.65	—
Pin grid array	0 to 70	1.50	1.50	1.75
	-40 to 85	1.65	1.65	—
Plastic LCC	0 to 70	1.50	1.50	—

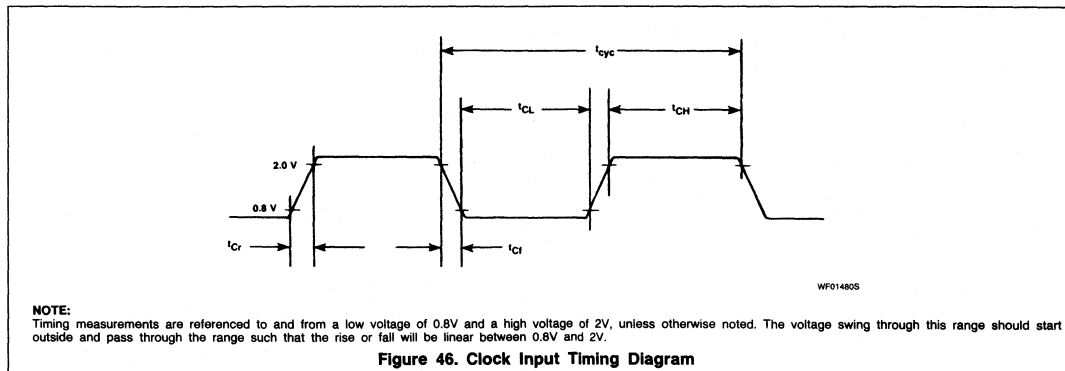

**NOTE:**

Timing measurements are referenced to and from a low voltage of 0.8V and a high voltage of 2V, unless otherwise noted. The voltage swing through this range should start outside and pass through the range such that the rise or fall will be linear between 0.8V and 2V.

Figure 46. Clock Input Timing Diagram

## 16-/32-Bit Microprocessor

SCN68000

**AC ELECTRICAL CHARACTERISTICS** — Read and Write Cycles  $V_{CC} = 5V_{DC} \pm 5\%$ ;  $GND = 0V_{DC}$ ;  $T_A = T_L$  to  $T_H$   
(see Figures 47 and 48)

NO.	CHARACTERISTIC	8MHz		10MHz		12.5MHz		UNIT
		Min	Max	Min	Max	Min	Max	
1	Clock period	125	250	100	250	80	250	ns
2	Clock width low	55	125	45	125	35	125	ns
3	Clock width high	55	125	45	125	35	125	ns
4	Clock fall time	–	10	–	10	–	5	ns
5	Clock rise time	–	10	–	10	–	5	ns
6	Clock low to address valid	–	70	–	60	–	55	ns
6A	Clock high to FC valid	–	70	–	60	–	55	ns
7	Clock high to address data high impedance (maximum)	–	80	–	70	–	60	ns
8	Clock high to address/FC invalid (minimum)	0	–	0	–	0	–	ns
9 <sup>1</sup>	Clock high to $\overline{AS}$ , $\overline{DS}$ low	0	60	0	55	0	55	ns
11 <sup>2</sup>	Address valid to $\overline{AS}$ , $\overline{DS}$ low (read)/ $\overline{AS}$ low write	30	–	20	–	0	–	ns
11A <sup>2,7</sup>	FC valid to $\overline{AS}$ , $\overline{DS}$ low (read)/ $\overline{AS}$ low (write)	60	–	50	–	40	–	ns
12 <sup>1</sup>	Clock low to $\overline{AS}$ , $\overline{DS}$ high	–	70	–	55	–	50	ns
13 <sup>2</sup>	$\overline{AS}$ , $\overline{DS}$ high to address/FC invalid	30	–	20	–	10	–	ns
14 <sup>2,5</sup>	$\overline{AS}$ , $\overline{DS}$ width low (read)/ $\overline{AS}$ low (write)	240	–	195	–	160	–	ns
14A <sup>2</sup>	$\overline{DS}$ width low (write)	115	–	95	–	80	–	ns
15 <sup>2</sup>	$\overline{AS}$ , $\overline{DS}$ width high	150	–	105	–	65	–	ns
16	Clock high to control bus high impedance	–	80	–	70	–	60	ns
17 <sup>2</sup>	$\overline{AS}$ , $\overline{DS}$ high to R/ $\overline{W}$ high (read)	40	–	20	–	10	–	ns
18 <sup>1</sup>	Clock high to R/ $\overline{W}$ high	0	70	0	60	0	60	ns
20 <sup>1</sup>	Clock high to R/ $\overline{W}$ low (write)	–	70	–	60	–	60	ns
20A <sup>8</sup>	$\overline{AS}$ low to R/ $\overline{W}$ valid	–	20	–	20	–	20	ns
21 <sup>2</sup>	Address valid to R/ $\overline{W}$ low (write)	20	–	0	–	0	–	ns
21A <sup>2,7</sup>	FC valid to R/ $\overline{W}$ low (write)	60	–	50	–	30	–	ns
22 <sup>2</sup>	R/ $\overline{W}$ low to $\overline{DS}$ low (write)	80	–	50	–	30	–	ns
23	Clock low to data out valid (write)	–	70	–	55	–	55	ns
25 <sup>2</sup>	$\overline{AS}$ , $\overline{DS}$ high to data out invalid (write)	30	–	20	–	15	–	ns
26 <sup>2</sup>	Data out valid to $\overline{DS}$ low (write)	30	–	20	–	15	–	ns
27 <sup>6</sup>	Data in to clock low (setup time on read)	15	–	10	–	10	–	ns
28 <sup>2,5</sup>	$\overline{AS}$ , $\overline{DS}$ high to $\overline{DTACK}$ high	0	245	0	190	0	150	ns
29	$\overline{AS}$ , $\overline{DS}$ high to data in invalid (hold time on read)	0	–	0	–	0	–	ns
30	$\overline{AS}$ , $\overline{DS}$ high to $\overline{BERR}$ high	0	–	0	–	0	–	ns
31 <sup>2,6</sup>	$\overline{DTACK}$ low to data in (setup time)	–	90	–	65	–	50	ns
32	$\overline{HALT}$ and $\overline{RESET}$ input transition time	0	200	0	200	0	200	ns
33	Clock high to $\overline{BG}$ low	–	70	–	60	–	50	ns
34	Clock high to $\overline{BG}$ high	–	70	–	60	–	50	ns
35	$\overline{BR}$ low to $\overline{BG}$ low	1.5	90ns +3.5	1.5	80ns +3.5	1.5	70ns +3.5	Clk. per.
36 <sup>9</sup>	$\overline{BR}$ high to $\overline{BG}$ high	1.5	90ns +3.5	1.5	80ns +3.5	1.5	70ns +3.5	Clk. per.

## 16-/32-Bit Microprocessor

SCN68000

## AC ELECTRICAL CHARACTERISTICS — Read and Write (Continued)

NO.	CHARACTERISTIC	8MHz		10MHz		12.5MHz		UNIT
		Min	Max	Min	Max	Min	Max	
37	$\overline{BGACK}$ low to $\overline{BG}$ low	1.5	90ns +3	1.5	80ns +3	1.5	70ns +3	Clk. per.
37A <sup>10</sup>	$\overline{BGACK}$ low to $\overline{BR}$ high	20	1.5 clocks	20	1.5 clocks	20	1.5 clocks	ns
38	$\overline{BG}$ low to control, address, data bus high impedance ( $\overline{AS}$ high)	100	–	80	–	70	–	60
39	$\overline{BG}$ width high	1.5	–	1.5	–	1.5	–	Clk. per.
40	Clock low to $\overline{VMA}$ low	–	70	–	70	–	70	ns
41	Clock low to E transition	–	70	–	55	–	45	ns
42	E output rise and fall time	–	25	–	25	–	25	ns
43	$\overline{VMA}$ low to E high	200	–	150	–	90	–	ns
44	$\overline{AS}$ , $\overline{DS}$ high to $\overline{VPA}$ high	0	120	0	90	0	70	ns
45	E low to control, address bus invalid (address hold time)	30	–	10	–	10	–	ns
46	$\overline{BGACK}$ width low	1.5	–	1.5	–	1.5	–	Clk. per.
47 <sup>6</sup>	Asynchronous input setup time	20	–	20	–	20	–	ns
48 <sup>3</sup>	$\overline{BERR}$ low to $\overline{DTACK}$ low	20	–	20	–	20	–	ns
49 <sup>11</sup>	$\overline{AS}$ , $\overline{DS}$ high to E low	–70	70	–55	55	–45	45	ns
50	E width high	450	–	350	–	280	–	ns
51	E width low	700	–	550	–	440	–	ns
53	Clock high to data out invalid	0	–	0	–	0	–	ns
54	E low to data out invalid	30	–	20	–	15	–	ns
55	$R/\overline{W}$ to data bus driver	30	–	20	–	10	–	ns
56 <sup>4</sup>	$\overline{HALT}/\overline{RESET}$ pulse width	10	–	10	–	10	–	Clk. per.
57	$\overline{BGACK}$ high to control bus driven	1.5	–	1.5	–	1.5	–	Clk. per.
58 <sup>9</sup>	$\overline{BG}$ high to control bus driven	1.5	–	1.5	–	1.5	–	Clk. per.

## NOTES:

- For a loading capacitance of less than or equal to 50pF, subtract 5ns from the values given in these columns.
- Actual value depends on clock period.
- If #47 is satisfied for both  $\overline{DTACK}$  and  $\overline{BERR}$ , #48 may be 0ns.
- For power up, the MPU must be held in  $\overline{RESET}$  state for 100ms to allow stabilization of on-chip circuitry. After the system is powered up, #56 refers to the minimum pulse width required to reset the system.
- #14, #14A, and #28 are one clock period less than the given number for T6E, BF4, and R9M mask sets.
- If the asynchronous setup time (#47) requirements are satisfied, the  $\overline{DTACK}$  low-to-data setup time (#31) requirement can be ignored. The data must only satisfy the data-in clock-low setup time (#27) for the following cycle.
- For T6E, BF4, and R9M mask set #11A timing equals #11, and #21A equals #21. #20A may be 0 for T6E, BF4, and R9M mask sets.
- When  $\overline{AS}$  and  $R/\overline{W}$  are equally loaded ( $\pm 20\%$ ), subtract 10ns from the values given in these columns.
- The processor will negate  $\overline{BG}$  and begin driving the bus again if external arbitration logic negates  $\overline{BR}$  before asserting  $\overline{BGACK}$ .
- The minimum value must be met to guarantee proper operation. If the maximum value is exceeded,  $\overline{BG}$  may be reasserted.
- The falling edge of S6 triggers both the negation of the strobes ( $\overline{AS}$  and  $\overline{DS}$ ) and the falling edge of E. Either of these events can occur first, depending upon the loading on each signal. Specification #49 indicates the absolute maximum skew that will occur between the rising edge of the strobes and the falling edge of the E clock.

# 16-/32-Bit Microprocessor

# SCN68000

These waveforms should only be referenced in regard to the edge-to-edge measurement of the timing specifications. They are not intended as a functional description of the input and output signals. Refer to other functional descriptions and their related diagrams for device operation.

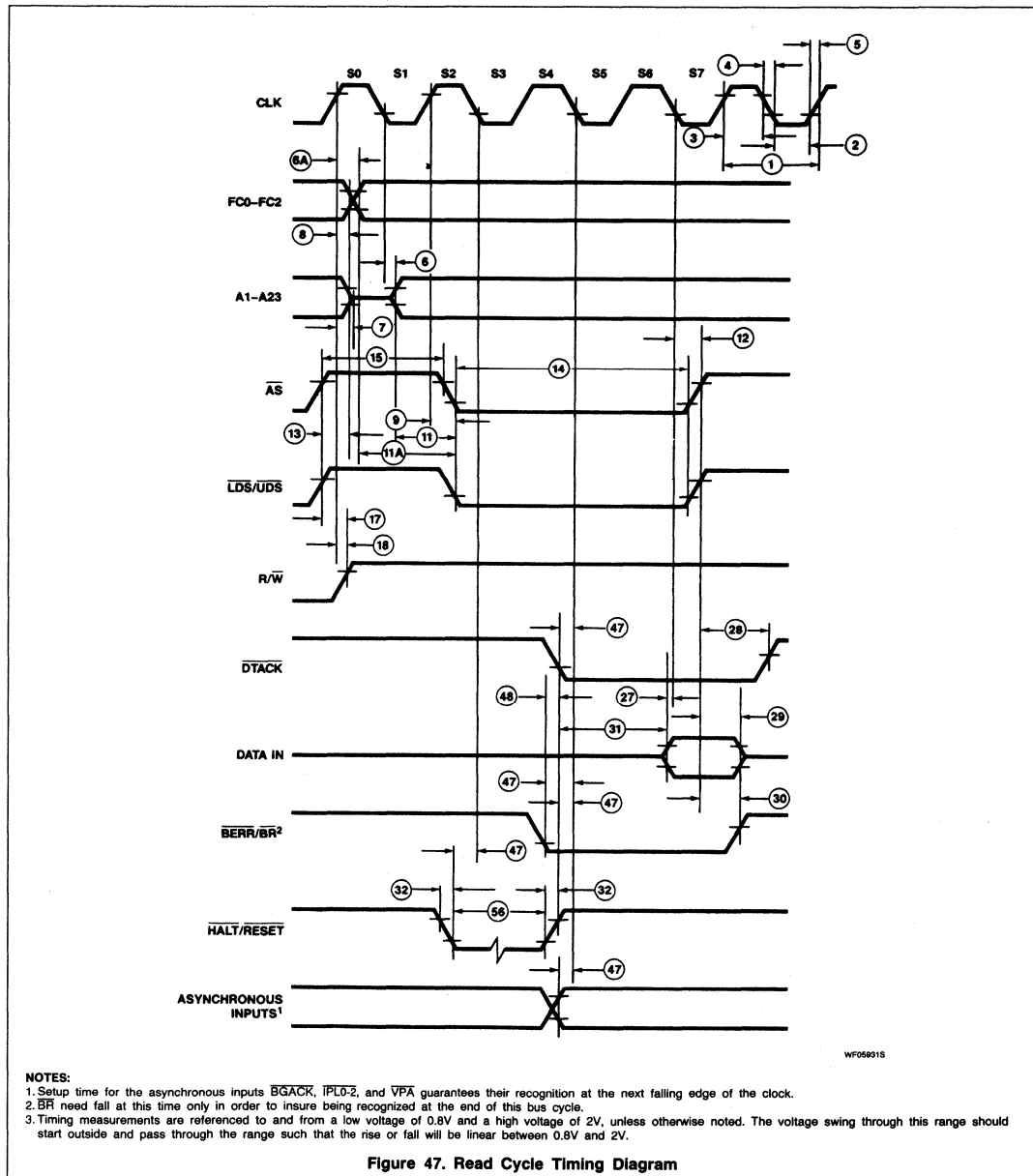

16-/32-Bit Microprocessor

SCN68000

These waveforms should only be referenced in regard to the edge-to-edge measurement of the timing specifications. They are not intended as a functional description of the input and output signals. Refer to other functional descriptions and their related diagrams for device operation.

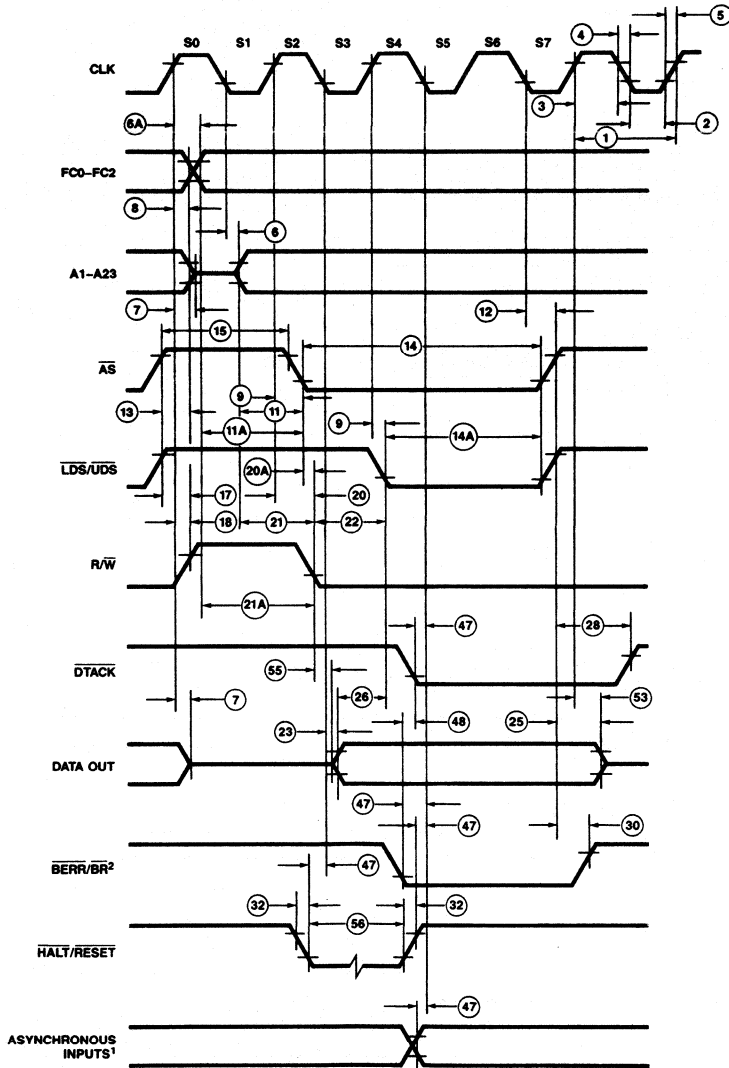

NOTES:

1. Timing measurements are referenced to and from a low voltage of 0.8V and a high voltage of 2V, unless otherwise noted. The voltage swing through this range should start outside and pass through the range such that the rise or fall will be linear between 0.8V and 2V.
2. Because of loading variations, R/W may be valid after AS even though both are initiated by the rising edge of S2 (Specification 20A).

WF059415

Figure 48. Write Cycle Timing Diagram

# 16-/32-Bit Microprocessor

# SCN68000

## AC ELECTRICAL CHARACTERISTICS - SCN68000 To Synchronous Peripheral $V_{CC} = 5V_{DC} \pm 5\%$ ; $GND = 0V_{DC}$ , $T_A = T_L$ to $T_H$ (refer to Figures 49 and 50)

NO.	CHARACTERISTIC	8MHz		10MHz		12.5MHz		UNIT
		Min	Max	Min	Max	Min	Max	
12	Clock low to $\overline{AS}$ , $\overline{DS}$ high	-	70	-	55	-	50	ns
18	Clock high to R/W high	0	70	0	60	0	60	ns
20	Clock high to R/W low (write)	-	70	-	60	-	60	ns
23	Clock low to data out valid (write)	-	70	-	55	-	55	ns
27	Data in to clock low (setup time on read)	15	-	10	-	10	-	ns
29	$\overline{AS}$ , $\overline{DS}$ high to data in invalid (hold time on read)	0	-	0	-	0	-	ns
40	Clock low to $\overline{VMA}$ low	-	70	-	70	-	70	ns
41	Clock low to E transition	-	70	-	55	-	45	ns
42	E output rise and fall time	-	25	-	25	-	25	ns
43	$\overline{VMA}$ low to E high	200	-	150	-	90	-	ns
44	$\overline{AS}$ , $\overline{DS}$ high to $\overline{VPA}$ high	0	120	0	90	0	70	ns
45	E low to control, address bus invalid (address hold time)	30	-	10	-	10	-	ns
47	Asynchronous input setup time	20	-	20	-	20	-	ns
49 <sup>1</sup>	$\overline{AS}$ , $\overline{DS}$ high to E low	-70	70	-55	55	-45	45	ns
50	E width high	450	-	350	-	280	-	ns
51	E width low	700	-	550	-	440	-	ns
54	E low to data out valid	30	-	20	-	15	-	ns

**NOTE:**

1. The falling edge of S6 triggers both the negation of the strobes ( $\overline{AS}$  and  $\overline{DS}$ ) and the falling edge of E. Either of these events can occur first, depending upon the loading on each signal. Specification # 49 indicates the absolute maximum skew that will occur between the rising edge of the strobes and the falling edge of the E clock.

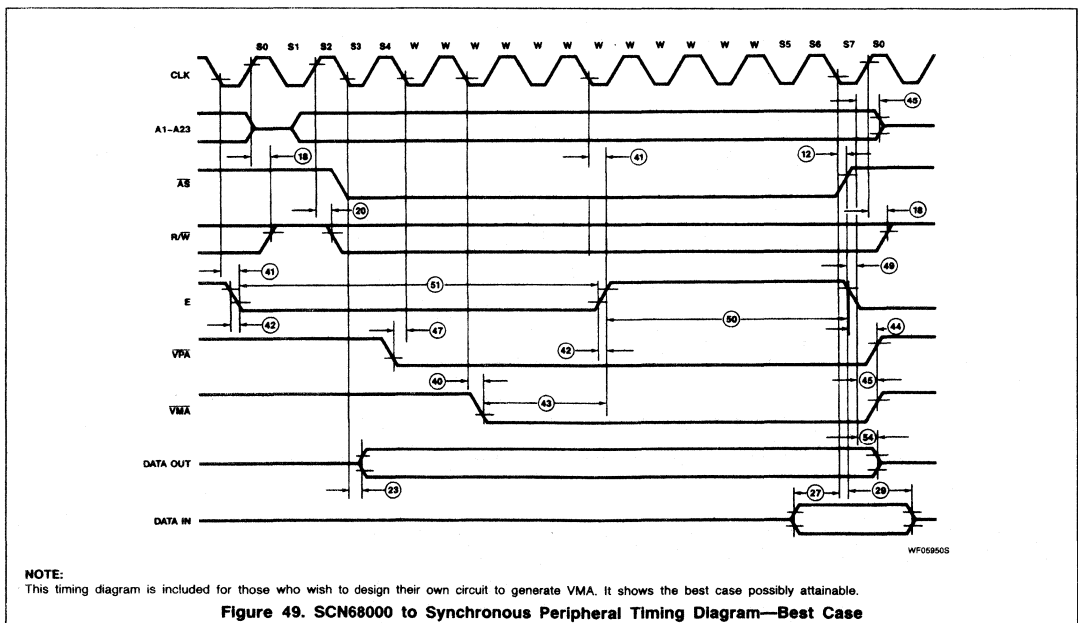

**NOTE:**

This timing diagram is included for those who wish to design their own circuit to generate VMA. It shows the best case possibly attainable.

**Figure 49. SCN68000 to Synchronous Peripheral Timing Diagram—Best Case**



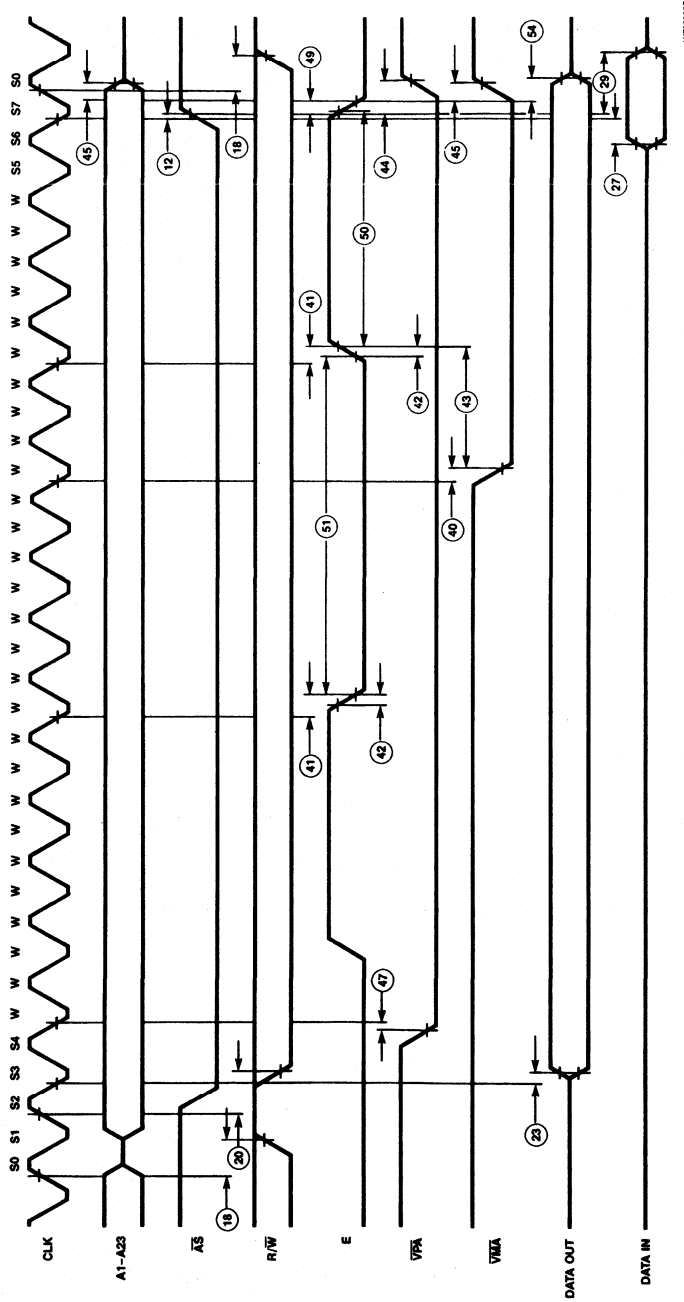

**NOTE:**  
This timing diagram is included for those who wish to design their own circuit to generate VMA. It shows the worst case possibly attainable.

Figure 50. SCN68000 to Synchronous Peripheral Timing Diagram—Worst Case

## 16-/32-Bit Microprocessor

SCN68000

**AC ELECTRICAL CHARACTERISTICS — Bus Arbitration**  $V_{CC} = 5V_{DC} \pm 5\%$ ;  $GND = 0V_{DC}$ ;  $T_A = T_L$  to  $T_H$  (see Figures 51, 52, 53)

NO.	CHARACTERISTIC	8MHz		10MHz		12.5MHz		UNIT
		Min	Max	Min	Max	Min	Max	
7	Clock high to address, data bus high impedance	–	80	–	70	–	60	ns
16	Clock high to control bus high impedance	–	80	–	70	–	60	ns
33	Clock high to $\overline{BG}$ low	–	70	–	60	–	50	ns
34	Clock high to $\overline{BF}$ high	–	70	–	60	–	50	ns
35	$\overline{BF}$ low to $\overline{BG}$ low	1.5	90ns +3.5	1.5	80ns +3.5	1.5	70ns +3.5	Clk. per.
36 <sup>1</sup>	$\overline{BF}$ high to $\overline{BG}$ high	1.5	90ns +3.5	1.5	80ns +3.5	1.5	70ns +3.5	Clk. per.
37	$\overline{BGACK}$ low to $\overline{BG}$ high	1.5	90ns +3.5	1.5	80ns +3.5	1.5	70ns +3.5	Clk. per.
37A <sup>2</sup>	$\overline{BGACK}$ low to $\overline{BF}$ high	20	1.5 Clocks	20	1.5 Clocks	20	1.5 Clocks	ns
38	$\overline{BG}$ low to control, address, data bus high impedance ( $\overline{AS}$ high)	–	80	–	70	–	60	ns
39	$\overline{BG}$ width high	1.5	–	1.5	–	1.5	–	Clk. per.
46	$\overline{BGACK}$ width low	1.5	–	1.5	–	1.5	–	Clk. per.
47	Asynchronous input setup time	20	–	20	–	20	–	ns
57	$\overline{BGACK}$ high to control bus driven	1.5	–	1.5	–	1.5	–	Clk. per.
58 <sup>1</sup>	$\overline{BG}$ high to control bus driven	1.5	–	1.5	–	1.5	–	Clk. per.

**NOTES:**

1. The processor will negate  $\overline{BG}$  and begin driving the bus again if external arbitration logic negates  $\overline{BF}$  before asserting  $\overline{BGACK}$ .
2. The minimum value must be met to guarantee proper operation. If the maximum value is exceeded,  $\overline{BG}$  may be reasserted.

Figures 51, 52, and 53 depict the three bus arbitration cases that can arise. Figure 51 shows the timing where  $\overline{AS}$  is negated when the processor asserts  $\overline{BG}$  (idle bus case). Figure 52 shows the timing where  $\overline{AS}$  is asserted when the processor asserts  $\overline{BG}$

(active bus case). Figure 53 shows the timing where more than one bus master are requesting the bus. Refer to **Bus Arbitration** for a complete discussion of bus arbitration.

The waveforms shown in Figures 51, 52, and 53 should only be referenced in regard to the

edge-to-edge measurement of the timing specifications. They are not intended as a functional description of the input and output signals. Refer to other functional descriptions and their related diagrams for device operation.

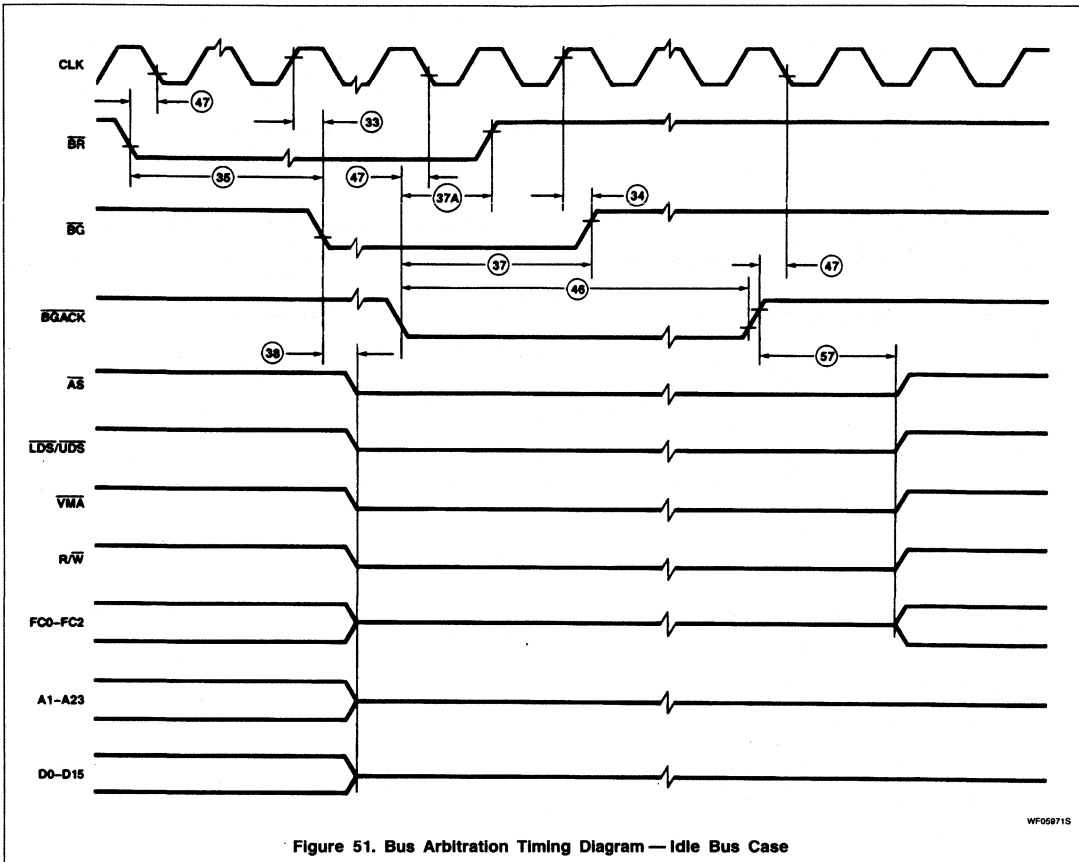

16-/32-Bit Microprocessor

SCN68000

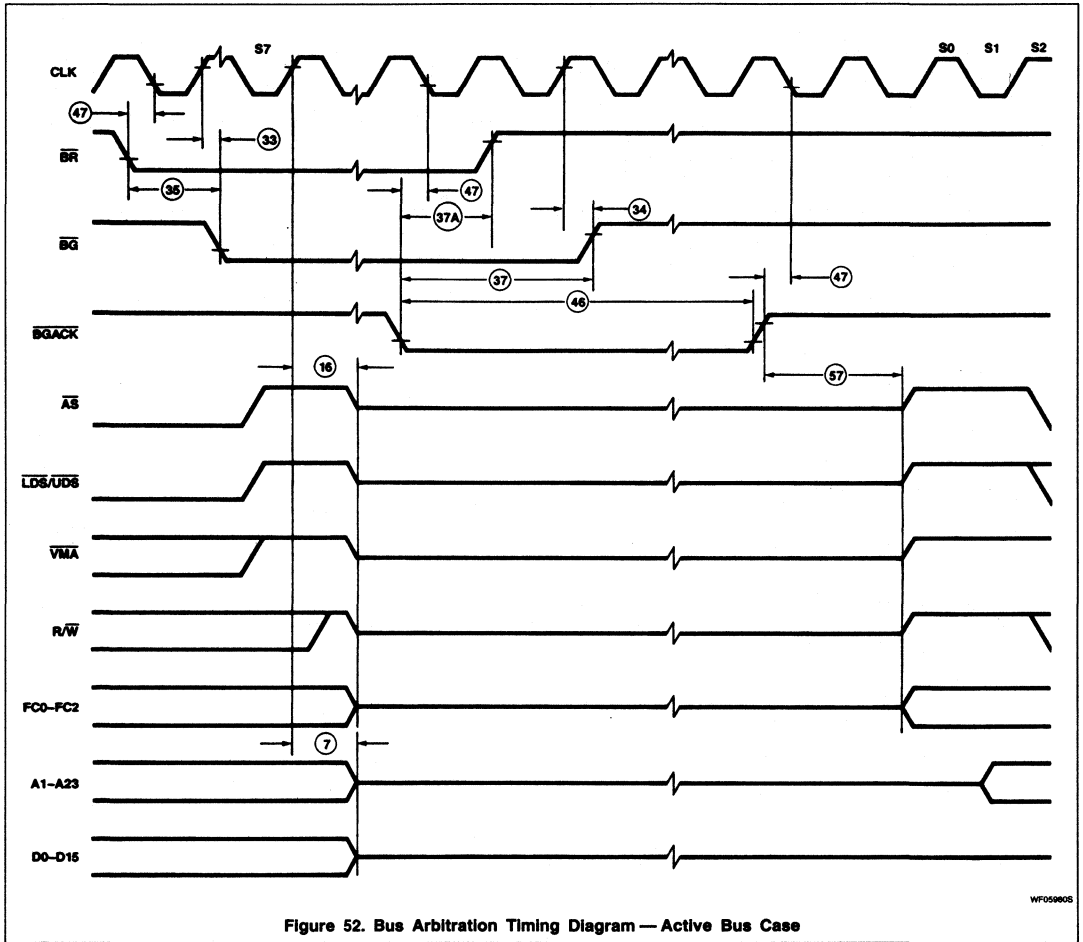

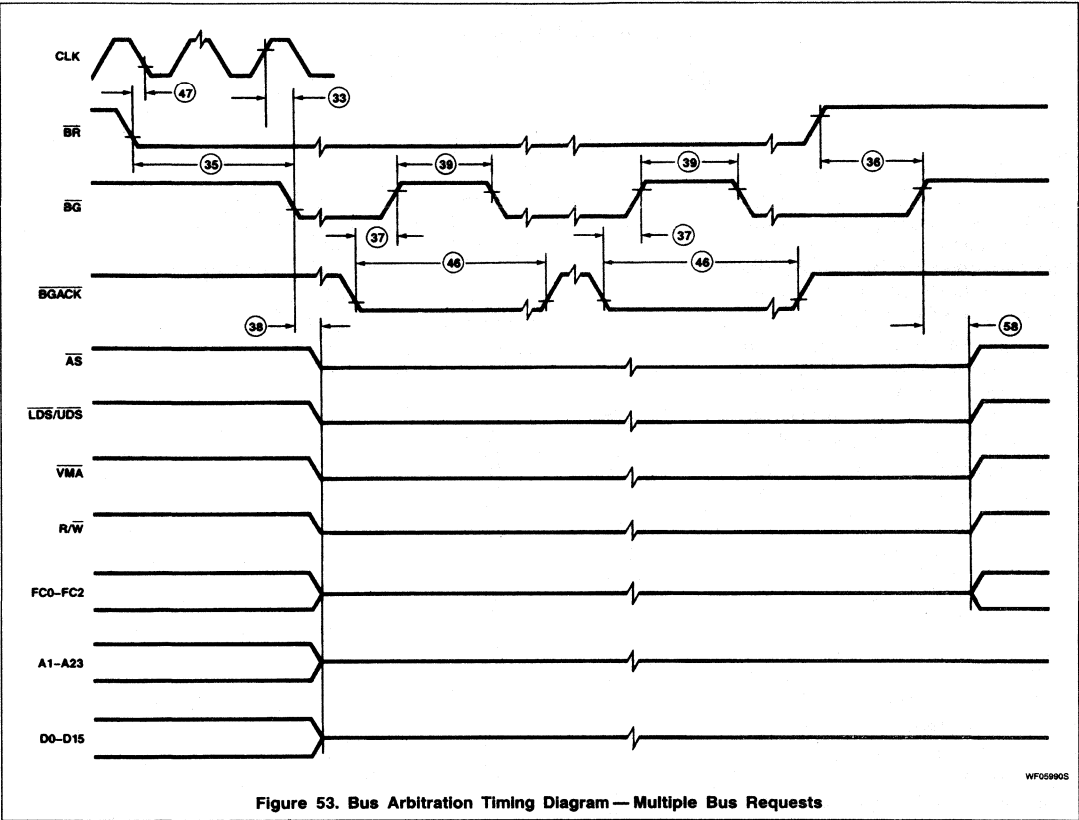

Figure 53. Bus Arbitration Timing Diagram — Multiple Bus Requests

# SCN68010

## 16-Bit Virtual Memory Microprocessor

### Product Specification

#### Microprocessor Products

#### DESCRIPTION

The SCN68010 is the third member of a family of advanced microprocessors from Signetics. Utilizing VLSI technology, the SCN68010 is a fully-implemented 16-bit microprocessor with 32-bit registers, a rich basic instruction set, and versatile addressing modes.

The SCN68010 is fully object code compatible with the earlier members of the S68000 family and has the added features of virtual memory support and enhanced instruction execution timing.

The SCN68010 possesses an asynchronous bus structure with a 24-bit address bus and a 16-bit data bus.

The resources available to the SCN68010 user consist of the following:

- 17 32-bit data and address registers
- 16-megabyte direct addressing range
- Virtual memory/machine support
- 57 powerful instruction types
- High performance looping instructions
- Operations on five main data types
- Memory mapped I/O
- 14 addressing modes

As shown in the programming model (Figures 1 and 2), the SCN68010 offers 17 32-bit general purpose registers, a 32-bit program counter, a 16-bit status register, a 32-bit vector base register, and two 3-bit alternate function code registers. The first eight registers (D0 - D7) are used as data registers for byte (8-bit), word (16-bit), and long word (32-bit) operations. The second set of seven registers (A0 - A6) and the stack pointers (SSP, USP) may be used as software stack pointers and base address registers. In addition, the address registers may be used for word and long word operations. All of the 17 registers may be used as index registers.

#### PIN CONFIGURATIONS

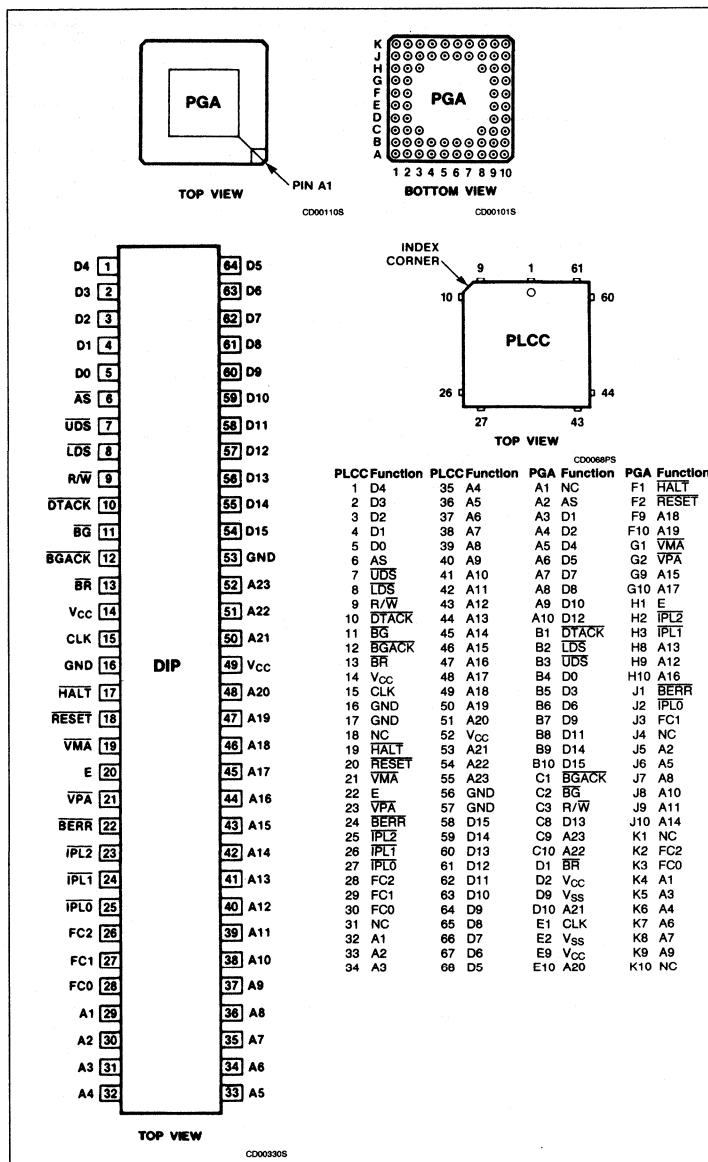

# 16-Bit Virtual Memory Microprocessor

# SCN68010

## ORDERING INFORMATION

PACKAGES	$V_{CC} = 5V \pm 5\%$ , $T_A = 0^\circ C$ to $70^\circ C$		
	8MHz	10MHz	12.5MHz
Ceramic DIP	SCN68010C8I64	SCN68010CAI64	SCN68010CBI64
Plastic DIP	SCN68010C8N64	SCN68010CAN64	SCN68010CBN64
Plastic LCC	SCN68010C8A68	SCN68010CAA68	SCN68010CBA68
Pin Grid Array	SCN68010C8P68	SCN68010CAP68	SCN68010CBP68

**2**

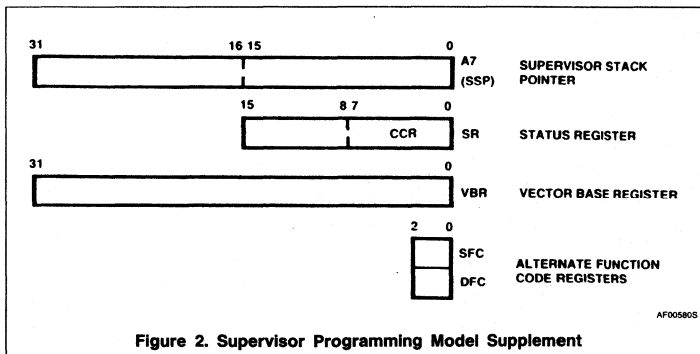
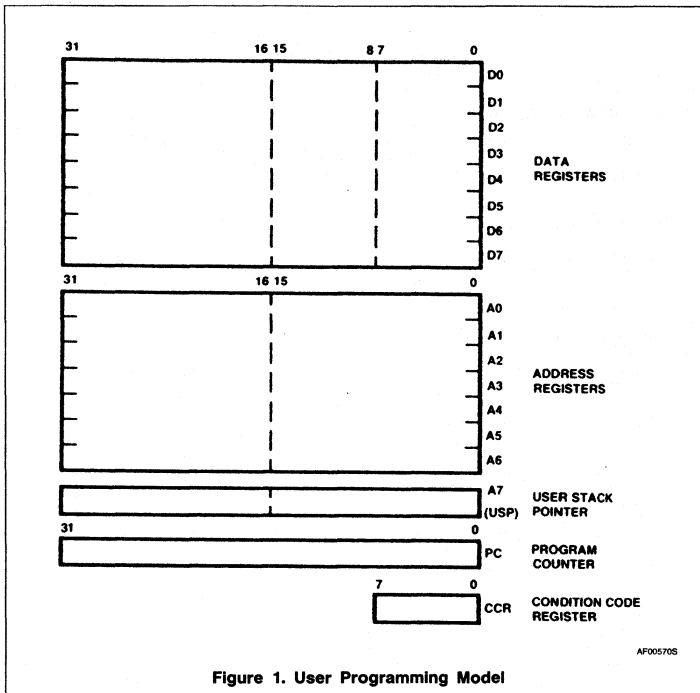

# 16-Bit Virtual Memory Microprocessor

SCN68010

The status register (Figure 3) contains the interrupt mask (eight levels available) as well as the condition codes; extend (X), negative (N), zero (Z), overflow (V), and carry (C). Additional status bits indicate that the processor is in the trace (T) mode and in the supervisor (S) or user state.

The vector base register is used to determine the location of the exception vector table in memory to support multiple vector tables. The alternate function code registers allow the supervisor to access user data space or emulate CPU space cycles.

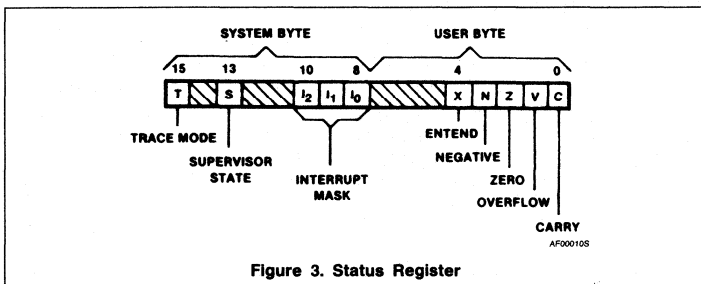

## Data Types and Addressing Modes

Five basic data types are supported. These data types are:

- Bits
- BCD digits (4 bits)
- Bytes (8 bits)
- Words (16 bits)
- Long words (32 bits)

In addition, operations on other data types such as memory addresses, status word data, etc., are provided in the instruction set.

The 14 address modes, shown in Table 1, include six basic types:

- Register direct
- Register indirect
- Absolute
- Program counter relative
- Immediate
- Implied

Included in the register indirect addressing modes is the capability to do postincrementing, predecrementing, offsetting, and indexing. The program counter relative mode can also be modified via indexing and offsetting.

Table 1. Addressing Modes

MODE	GENERATION
<b>Register direct addressing</b>	
Data register direct Address register direct	EA = Dn EA = An
<b>Absolute data addressing</b>	
Absolute short Absolute long	EA = (next word) EA = (next two words)
<b>Program counter relative addressing</b>	
Relative with offset Relative with index and offset	EA = (PC) + d <sub>16</sub> EA = (PC) + (Xn) + d <sub>8</sub>
<b>Register indirect addressing</b>	
Register indirect Postincrement register indirect Predecrement register indirect Register indirect with offset Indexed register indirect with offset	EA = (An) EA = (An), An ← An + N An ← An - N, EA = (An) EA = (An) + d <sub>16</sub> EA = (An) + (Xn) + d <sub>8</sub>
<b>Immediate data addressing</b>	
Immediate Quick immediate	DATA = next word(s) inherent data
<b>Implied addressing</b>	
Implied register	EA = SR, USP, SSP, PC VBR, SFC, DFC

**NOTES:**

- EA = Effective address
- An = Address register
- Dn = Data register
- Xn = Address or data register used as index register
- SR = Status register
- PC = Program counter
- ( ) = Contents of
- d<sub>8</sub> = 8-bit offset (displacement)
- d<sub>16</sub> = 16-bit offset (displacement)
- N = 1 for byte, 2 for word, and 4 for long word. If An is the stack pointer and the operand size is byte, N = 2 to keep the stack pointer on a word boundary.
- ← = Replaces



## 16-Bit Virtual Memory Microprocessor

SCN68010

**Instruction Set Overview**

The SCN68010 instruction set is shown in Table 2. Some additional instructions are variations, or subsets, of these and they appear in Table 3. Special emphasis has been given to the instruction set's support of structured high-level languages to facilitate ease of programming. Each instruction, with few exceptions, operates on bytes, words, and long words and most instructions can use any of the 14 addressing modes. By combining instruction types, data types, and addressing modes, over 1000 useful instructions are provided. These instructions include signed and unsigned multiply and divide, "quick" arithmetic operations, BCD arithmetic, and expanded operations (through traps). Also, 33 instructions may be used in the loop mode with certain addressing modes and the DBcc instruction to provide 230 high-performance string, block manipulation, and extended arithmetic operations.

**Table 2. Instruction Set**

MNEMONIC	DESCRIPTION
ABCD* ADD* AND* ASL* ASR*	Add decimal with extend Add Logical AND Arithmetic shift left Arithmetic shift right
Bcc BCHG BCLR BRA BSET BSR BTST	Branch conditionally Bit test and change Bit test and clear Branch always Bit test and set Branch to subroutine Bit test
CHK CLR* CMP*	Check register against bounds Clear operand Compare
DBcc DIVS DIVU	Decrement and branch conditionally Signed divide Unsigned divide
EOR* EXG EXT	Exclusive OR Exchange registers Sign extend
JMP JSR	Jump Jump to subroutine
LEA LINK LSL* LSR*	Load effective address Link stack Logical shift left Logical shift right
MOVE* MULS MULU	Move source to destination Signed multiply Unsigned multiply
NBCD* NEG* NOP NOT*	Negate decimal with extend Negate No operation One's complement
OR*	Logical OR
PEA	Push effective address
RESET ROL* ROR* ROXL* ROXR* RTD RTE RTR RTS	Reset external devices Rotate left without extend Rotate right without extend Rotate left with extend Rotate right with extend Return and deallocate Return from exception Return and restore Return from subroutine
SBCD* Scc STOP SUB SWAP	Subtract decimal with extend Set conditional Stop Subtract Swap data register halves
TAS TRAP TRAPV TST*	Test and set operand Trap Trap on overflow Test
UNLK	Unlink

**NOTE:**

\*Loopable instructions

## 16-Bit Virtual Memory Microprocessor

SCN68010

Table 3. Variations of Instruction Types

INSTRUCTION TYPE	VARIATION	DESCRIPTION
ADD	ADD* ADDA ADDQ ADDI ADDX*	Add Add address Add quick Add immediate Add with extend
AND	AND* ANDI ANDI to CCR ANDI to SR	Logical AND AND immediate AND immediate to condition codes AND immediate to status register
CMP	CMP* CMPA* CMPM* COMPI	Compare Compare address Compare memory Compare immediate
EOR	EOR* EORI EORI to CCR EORI to SR	Exclusive OR Exclusive OR immediate Exclusive OR immediate to condition codes Exclusive OR immediate to status register
MOVE	MOVE* MOVEA* MOVEC MOVEM MOVEP MOVEQ MOVES MOVE from SR MOVE to SR MOVE from CCR MOVE to CCR MOVE USP	Move source to destination Move address Move control register Move multiple registers Move peripheral data Move quick Move alternate address space Move from status register Move to status register Move from condition codes Move to condition codes Move user stack pointer
NEG	NEG* NEGX*	Negate Negate with extend
OR	OR* ORI ORI to CCR ORI to SR	Logical OR OR immediate OR immediate to condition codes OR immediate to status register
SUB	SUB* SUBA* SUBI SUBQ SUBX*	Subtract Subtract address Subtract immediate Subtract quick Subtract with extend

**NOTE:**

\*Loopable instructions

**Virtual Memory/Machine Concepts**

In most systems using the SCN68010 as the central processor, only a fraction of the 16Mbyte address space will actually contain physical memory. However, by using virtual memory techniques the system can be made to appear to the user to have 16Mbytes of physical memory available to him/her. These techniques have been used for several years in large mainframe computers and more re-

cently in minicomputers and now, with the SCN68010, can be fully supported in microprocessor-based systems.

In a virtual memory system, a user program can be written as though it has a large amount of memory available to it when only a small amount of memory is physically present in the system. In a similar fashion, a system can be designed in such a manner as to allow user programs to access other types of devices that are not physically present in the

system such as tape drives, disk drives, printers, or CRTs. With proper software emulation, a physical system can be made to appear to a user program as any other computer system and the program may be given full access to all of the resources of that emulated system. Such an emulated system is called a virtual machine.

**Virtual Memory**

The basic mechanism for supporting virtual memory in computers is to provide only a limited amount of high-speed physical memory that can be accessed directly by the processor while maintaining an image of a much larger "virtual" memory on secondary storage devices such as large capacity disk drives. When the processor attempts to access a location in the virtual memory map that is not currently residing in physical memory (referred to as a page fault), the access to that location is temporarily suspended while the necessary data is fetched from the secondary storage and placed in physical memory; the suspended access is then completed. The SCN68010 provides hardware support for virtual memory with the capability of suspending an instruction's execution when a bus error is signaled and then completing the instruction after the physical memory has been updated as necessary.

The SCN68010 uses instruction continuation rather than instruction restart to support virtual memory. With instruction restart, the processor must remember the exact state of the system before each instruction is started in order to restore that state if a page fault occurs during its execution. Then, after the page fault has been repaired, the entire instruction that caused the fault is reexecuted. With instruction continuation, when a page fault occurs the processor stores its internal state and then, after the page fault is repaired, restores that internal state and continues execution of the instruction. In order for the SCN68010 to utilize instruction continuation, it stores its internal state on the supervisor stack when a bus cycle is terminated with a bus error signal. It then loads the program counter from vector table entry number two (offset \$008) and resumes program execution at that new address. When the bus error exception handler routine has completed execution, an RTE instruction is executed which reloads the SCN68010 with the internal state stored on the stack, reruns the faulted bus cycle, and continues the suspended instruction. Instruction continuation has the additional advantage of allowing hardware support for virtual I/O devices. Since virtual registers may be simulated in the memory map, an access to such a register will cause a fault and the function of the register can be emulated by software.

# 16-Bit Virtual Memory Microprocessor

SCN68010

---



---

**2**

---



---

## Virtual Machine

One typical use for a virtual machine system is in the development of software such as an operating system for another machine with hardware also under development and not available for programming use. In such a system, the governing operating system (OS) emulates the hardware of the new system and allows the new OS to be executed and debugged as though it were running on the new hardware. Since the new OS is controlled by the governing OS, the new one must execute at a lower privilege level than the governing OS so that any attempts by the new OS to use virtual resources that are not physically present, and should be emulated, will be trapped by the governing OS and handled in software. In the SCN68010, a virtual machine may be fully supported by running the new OS in the user mode and the governing OS in the supervisor mode so that any attempts to access supervisor resources or execute privileged instructions by the new OS will cause a trap to the governing OS.

In order to fully support a virtual machine, the SCN68010 must protect the supervisor resources from access by user programs. The one supervisor resource that is not fully protected in the SCN68000 is the system byte of the status register. In the SCN68000, the MOVE from SR instruction allows user programs to test the S bit (in addition to the 1 bit and interrupt mask) and thus determine that they are running in the user mode. For full virtual machine support, a new OS must not be aware of the fact that it is running in the user mode and thus should not be allowed to access the S bit. For this reason, the MOVE from SR instruction on the SCN68010 is a privileged instruction and the MOVE from CCR instruction has been added to allow user programs unhindered access to the condition codes. By making the MOVE from SR instruction privileged, when the new OS attempts to access the S bit, a trap to the governing OS will occur and the SR image passed to the new OS by the governing OS will have the S bit set.

## DATA ORGANIZATION AND ADDRESSING CAPABILITIES

This section contains a description of the registers and the data organization of the SCN68010.

### Operand Size

Operand sizes are defined as follows: a byte equals 8 bits, a word equals 16 bits, and a long word equals 32 bits. The operand size for each instruction is either explicitly encoded in the instruction or implicitly defined by the instruction operation. Implicit instructions support some subset of all three sizes.

### Data Organization in Registers

The eight data registers support data operands of 1, 8, 16, or 32 bits. The seven address registers and the stack pointers support address operands of 32 bits. The four control registers support data of 1, 3, 8, 16, or 32 bits depending on the register specified.

### Data Registers

Each data register is 32 bits wide. Byte operands occupy the low order 8 bits, word operands the low order 16 bits, and long word operands the entire 32 bits. The least significant bit is addressed as bit zero; the most significant bit is addressed as bit 31.

When a data register is used as either a source or destination operand, only the appropriate low order portion is changed; the remaining high order portion is neither used nor changed.

### Address Registers

Each address register and stack pointer is 32 bits wide and holds a full 32-bit address. Address registers do not support the sized operands. Therefore, when an address register is used as a source operand, either the low order word or the entire long word operand is used depending upon the operation size. When an address register is used as the destination operand, the entire register is affected regardless of the operation size. If the operation size is word, any other operands are sign extended to 32 bits before the operation is performed.

### Control Registers

The status register (SR) is 16 bits wide with the lower byte being accessed as the condition code register (CCR). Not all 16 bits of the SR are defined and will be read as zeroes and ignored when written. Operations to the

CCR are word operations; however, the upper byte will be read as all zeros and ignored when written.

The vector base register (VBR) is 32 bits wide and holds a full 32-bit address. All operations involving the VBR are long word operations regardless of whether it is the source or destination operand.

The alternate function code registers (SFC and DFC) are three bits wide and contain the function code values placed on FC0-FC2 during the operand read or write of a MOVES instruction. All transfers to or from the alternate function code registers are 32 bits although the upper 29 bits will be read as zeroes and ignored when written.

### Data Organization in Memory

The data types supported by the SCN68010 are: bit data, integer data of 8, 16, or 32 bits, 32-bit addresses and binary coded decimal data. Each of these data types is put in memory, as shown in Figure 4. The numbers indicate the order in which the data would be accessed from the processor.

Bytes are individually addressable with the high order byte having an even address the same as the word, as shown in Figure 5. The low order byte has an odd address that is one count higher than the word address. Instructions and word or long word data are accessed only on word (even byte) boundaries. If a long word datum is located at address  $n$  ( $n$  even), then the low-order word of that datum is located at address  $n + 2$ .

### Addressing

Instructions for the SCN68010 contain two kinds of information: the type of function to be performed and the location of the operand(s) on which to perform that function. The methods used to locate (address) the operand(s) are explained in the following paragraphs.

Instructions specify an operand location in one of three ways:

Register Specification – the number of the register is given in the register field of their instruction.

Effective Address – use of the different effective addressing modes.

Implicit Reference – the definition of certain instructions implies the use of specific registers.

16-Bit Virtual Memory Microprocessor

SCN68010

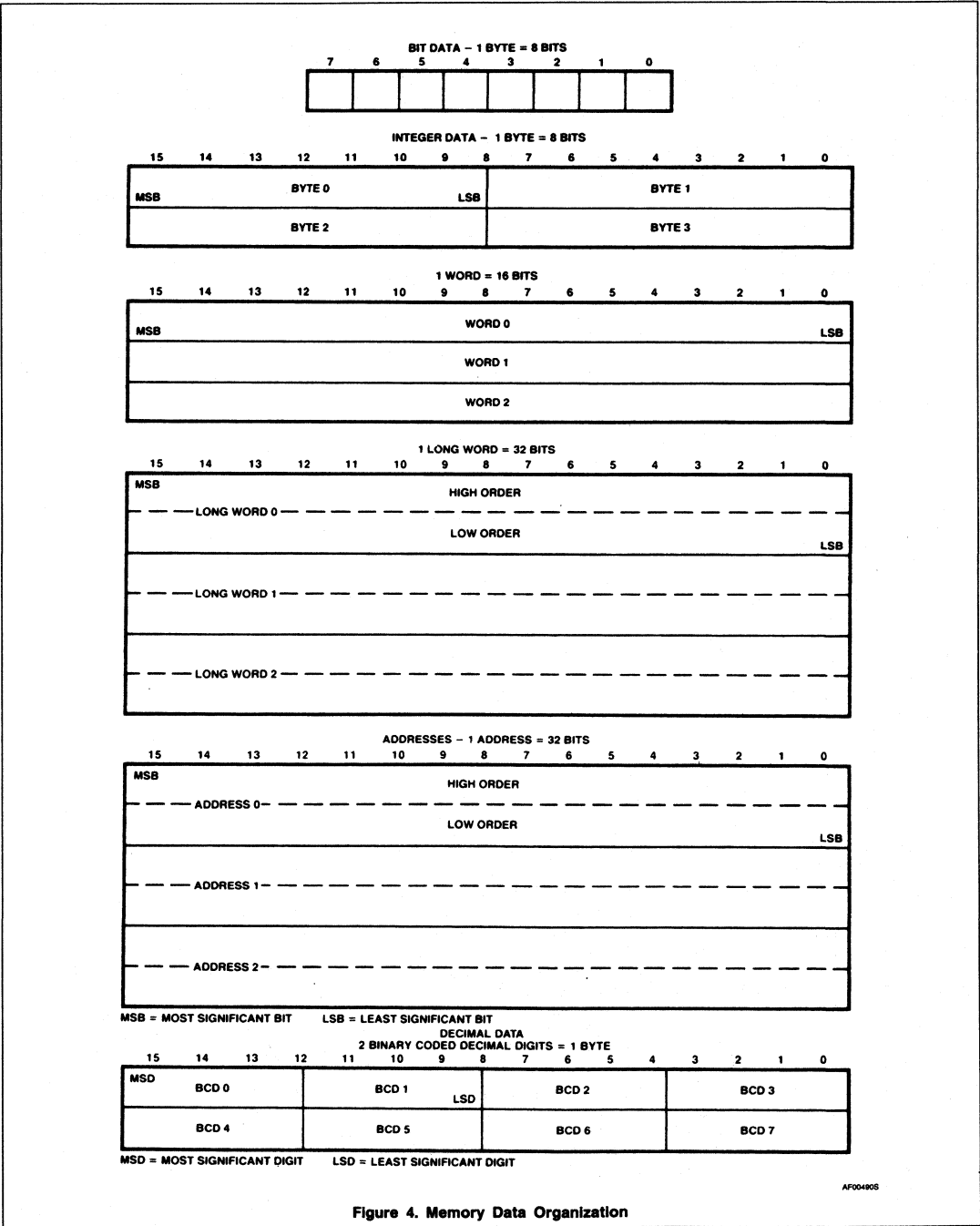

AF004805

Figure 4. Memory Data Organization

## 16-Bit Virtual Memory Microprocessor

SCN68010

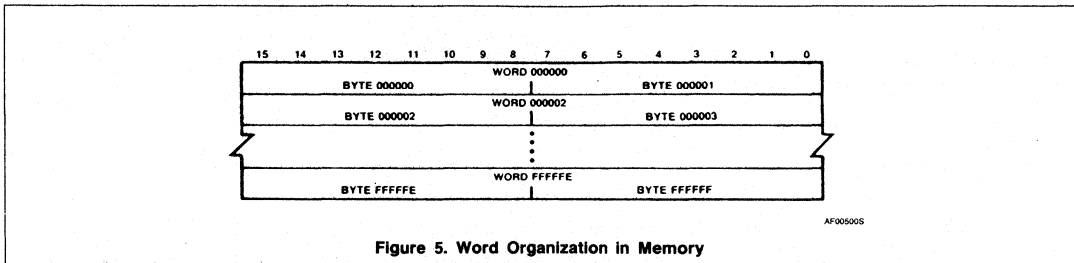

Figure 5. Word Organization in Memory

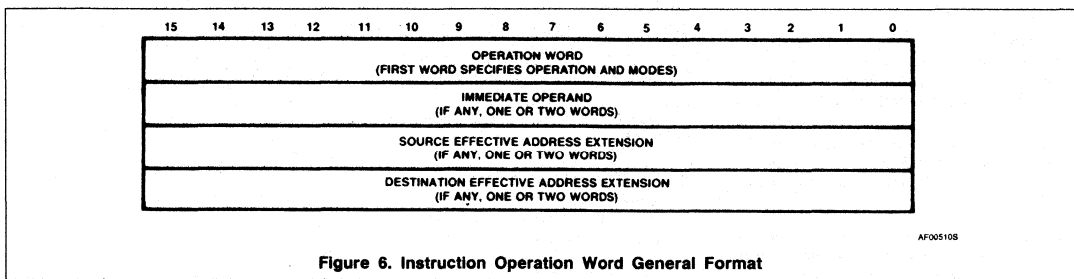

Figure 6. Instruction Operation Word General Format

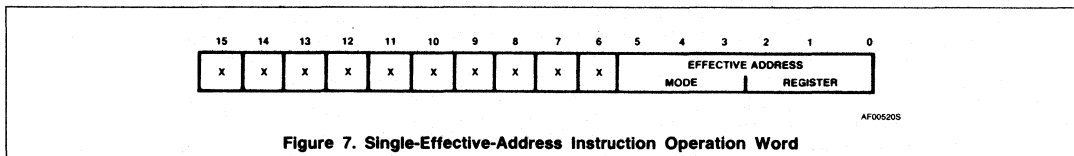

Figure 7. Single-Effective-Address Instruction Operation Word

**Instruction Format**

Instructions are from one to five words in length as shown in Figure 6. The length of the instruction and the operation to be performed is specified by the first word of the instruction which is called the operation word. The remaining words further specify the operands. These words are either immediate operands or extensions to the effective address mode specified in the operation word.

**Program/Data References**

The SCN68010 separates memory references into two classes: program references and data references. Program references, as the name implies, are references to that section of memory that contains the program being executed. Data references refer to that section of memory that contains data. Generally, operand reads are from the data space. All operand writes are to the data space.

**Register Specification**

The register field within an instruction specifies the register to be used. Other fields within the instruction specify whether the register selected is an address or data register and how the register is to be used.

**Effective Address**

Most instructions specify the location of an operand by using the effective address in the operation word. For example, Figure 7 shows the general format of the single-effective-address instruction operation word. The effective address is composed of two 3-bit fields: the mode field and the register field. The value in the mode field selects the different address modes. The register field contains the number of a register.

The effective address field may require additional information to fully specify the operand. This additional information, called the effective address extension, is contained in the following word or words and is considered part of the instruction, as shown in Figure 6. The effective address modes are grouped into three categories: register direct, memory addressing, and special.

**Register Direct Modes**

These effective addressing modes specify that the operand is in one of sixteen general purpose registers or one of four control registers.

**Data Register Direct** — The operand is in the data register specified by the effective address register field.

**Address Register Direct** — The operand is in the address register specified by the effective address register field.

**Memory Address Modes**

These effective addressing modes specify that the operand is in memory and provide the specific address of the operand.

**Address Register Indirect** — The address of the operand is in the address register specified by the register field. The reference is classified as a data reference with the exception of the jump and jump-to-subroutine instructions.

**Address Register Indirect with Post Increment** — The address of the operand is in the address register specified by the register field. After the operand address is used, it is incremented by one, two, or four depending upon whether the size of the operand is byte, word, or long word. If the address register is the stack pointer and the operand size is byte, the address is incremented by two rather than one to keep the stack pointer on a

## 16-Bit Virtual Memory Microprocessor

SCN68010

word boundary. The reference is classified as a data reference.

**Address Register Indirect with Predecrement** — The address of the operand is in the address register specified by the register field. Before the operand address is used, it is decremented by one, two, or four depending upon whether the operand size is byte, word, or long word. If the address register is the stack pointer and the operand size is byte, the address is decremented by two rather than one to keep the stack pointer on a word boundary. The reference is classified as a data reference.

**Address Register Indirect with Displacement** — This addressing mode requires one word of extension. The address of the operand is the sum of the address in the address register and the sign-extended 16-bit displacement integer in the extension word. The reference is classified as a data reference with the exception of the jump and jump-to-subroutine instructions.

**Address Register Indirect with Index** — This addressing mode requires one word of extension. The address of the operand is the sum of the address in the address register, the sign-extended displacement integer in the low order eight bits of the extension word, and the contents of the index register. The index may be specified as the sign extended low-order word or the long word in the index register. The reference is classified as a data reference with the exception of the jump and jump-to-subroutine instructions.

#### Special Address Modes

The special address modes use the effective address register field to specify the special addressing mode instead of a register number.

**Absolute Short Address** — This addressing mode requires one word of extension. The address of the operand is in the extension word. The 16-bit address is sign extended before it is used. The reference is classified as a data reference with the exception of the jump and jump-to-subroutine instructions.

**Absolute Long Address** — This addressing mode requires two words of extension. The address of the operand is developed by the concatenation of the extension words. The high order part of the address is the first extension word; the low order part of the address is the second extension word. The reference is classified as a data reference with the exception of the jump and jump-to-subroutine instructions.

**Program Counter with Displacement** — This addressing mode requires one word of extension. The address of the operand is the sum of the address in the program counter and the sign-extended 16-bit displacement

**Table 4. Effective Address Encoding Summary**

ADDRESSING MODE	MODE	REGISTER
Data register direct	000	Register number
Address register direct	001	Register number
Address register indirect	010	Register number
Address register indirect with postincrement	011	Register number
Address register indirect with predecrement	100	Register number
Address register indirect with displacement	101	Register number
Address register indirect with index	110	Register number
Absolute short	111	000
Absolute long	111	001
Program counter with displacement	111	010
Program counter with index	111	011
Immediate	111	100

integer in the extension word. The value in the program counter is the address of the extension word. The reference is classified as a program reference.

**Program Counter with Index** — This addressing mode requires one word of extension. The address is the sum of the address in the program counter, the sign-extended displacement integer in the lower eight bits of the extension word, and the contents of the index register. The index may be specified as the sign extended low-order word or the long word in the index register. The value in the program counter is the address of the extension word. The reference is classified as a program reference.

**Immediate Data** — This addressing mode requires either one or two words of extension depending on the size of the operation.

Byte Operation — operand is in the low order byte of extension word  
 Word Operation — operand is in the extension word  
 Long Word — operand is in the two extension words, high order 16 bits are in the first extension word, low order 16 bits are in the second extension word.

**Implicit Reference** — Some instructions make implicit reference to the program counter (PC), the system stack pointer (SP), the supervisor stack pointer (SSP), the user stack pointer (USP), the status register (SR), the condition code register (CCR), the vector base register (VBR), or the alternate function code registers (SFC or DFC).

A selected set of instructions may reference the status register by means of the effective address field. These are:

ANDI to CCR  
 ANDI to SR  
 EORI to CCR  
 EORI to SR  
 ORI to CCR  
 ORI to SR  
 MOVE to CCR  
 MOVE to SR  
 MOVE from SR

#### Effective Address Encoding Summary

Table 4 is a summary of the effective addressing modes discussed in the previous paragraphs.

#### System Stack

The system stack is used implicitly by many instructions; user stacks and queues may be created and maintained through the addressing modes. Address register seven (A7) is the system stack pointer (SP). The system stack pointer is either the supervisor stack pointer (SSP) or the user stack pointer (USP), depending on the state of the S bit in the status register. If the S bit indicates supervisor state, the SSP is the active system stack pointer and the USP cannot be referenced as an address register. If the S bit indicates user state, the USP is the active system stack pointer, and the SSP cannot be referenced. Each system stack fills from high memory to low memory.

#### INSTRUCTION SET SUMMARY

This section contains an overview of the form and structure of the SCN68010 instruction set. The instructions form a set of tools that include all the machine functions to perform the following operations:

Data movement	Bit manipulation
Integer arithmetic	Binary code decimal
Logical	Program control
Shift and rotate	System control

The complete range of instruction capabilities combined with the flexible addressing modes

## 16-Bit Virtual Memory Microprocessor

SCN68010

described previously provide a very flexible base for program development.

### Data Movement Operations

The basic method of data acquisition (transfer and storage) is provided by the move (MOVE) instruction. The move instruction and the effective addressing modes allow both address and data manipulation. Data movement instructions allow byte, word, and long word operands to be transferred from memory to memory, memory to register, register to memory, and register to register. Address movement instructions allow word and long word operand transfers and ensure that only legal address manipulations are executed. In addition to the general move instruction there are several special data movement instructions: move multiple registers (MOVEM), move peripheral data (MOVEP), exchange registers (EXG), load effective address (LEA), push effective address (PEA), link stack (LINK), unlink stack (UNLK), move quick (MOVEQ), move control register (MOVECS), and move alternate address space (MOVES). Table 5 is a summary of the data movement operations.

### Integer Arithmetic Operations

The arithmetic operations include the four basic operations of add (ADD), subtract (SUB), multiply (MUL), and divide (DIV) as well as arithmetic compare (CMP), clear (CLR), and negate (NEG). The add and subtract instructions are available for both address and data operations, with data operations accepting all operand sizes. Address operations are limited to legal address size operands (16 or 32 bits). Data, address, and memory compare operations are also available. The clear and negate instructions may be used on all sizes of data operands.

The multiply and divide operations are available for signed and unsigned operands using word multiply to produce a long word product, and a long word dividend with word divisor to produce a word quotient with a word remainder.

Multiprecision and mixed size arithmetic can be accomplished using a set of extended instructions. These instructions are: add extended (ADDX), subtract extended (SUBX), sign extend (EXT), and negate binary with extend (NEGX).

**Table 5. Data Movement Operations**

INSTRUCTION	OPERAND SIZE	OPERATION
EXG	32	Rx ↔ Ry
LEA	32	EA → An
LINK	-	(An) → -(SP) (SP) → An (SP) + displacement → SP
MOVE	8, 16, 32	(EA)s → EAd
MOVEC	32	(Rn) → Cr (Cr) → Rn
MOVEM	16, 32	(EA) → An, Dn An, Dn → EA
MOVES	8, 16, 32	(EA) → Rn (Rn) → EA
MOVEP	16, 32	d(An) → Dn Dn → d(An)
MOVEQ	8	#xxx → Dn
PEA	32	EA → -(SP)
SWAP	32	Dn[31:16] ↔ Dn[15:0]
UNLK	-	An → Sp (SP) + → An

**NOTES:**

s = source  
d = destination

[ ] = bit numbers  
- ( ) = indirect with predecrement

( ) + = indirect with postdecrement  
# = immediate data

**Table 6. Integer Arithmetic Operations**

INSTRUCTION	OPERAND SIZE	OPERATION
ADD	8, 16, 32 16, 32	(Dn) + (EA) → Dn (EA) + (Dn) → EA (EA) + #xxx → EA (An) + (EA) → An
ADDX	8, 16, 32 16, 32	(Dx) + (Dy) + X → Dx -(Ax) + -(Ay) + X → (Ax)
CLR	8, 16, 32	0 → (EA)
CMP	8, 16, 32 16, 32	(Dn) - (EA) (EA) - #xxx (Ax) + -(Ay) + (An) - (EA)
DIVS	32 ÷ 16	(Dn)/(EA) → Dn
DIVU	32 ÷ 16	(Dn)/(EA) → Dn
EXT	8 → 16 16 → 32	(Dn) <sub>8</sub> → Dn <sub>16</sub> (Dn) <sub>16</sub> → Dn <sub>32</sub>
MULS	16 × 16 → 32	(Dn) × (EA) → Dn
MULU	16 × 16 → 32	(Dn) × (EA) → Dn
NEG	8, 16, 32	0 - (EA) → EA
NEGX	8, 16, 32	0 - (EA) - X → EA
SUB	8, 16, 32 16, 32	(Dn) - (EA) → Dn (EA) - Dn → EA (EA) - #xxx → EA (An) - (EA) → An
SUBX	8, 16, 32	(Dx) - (Dy) - X → Dx -(Ax) - -(Ay) - X → (Ax)
TAS	8	[EA] - 0, 1 → EA[7]
TST	8, 16, 32	(EA) - 0

**NOTES:**

[ ] = bit number  
# = immediate data

- ( ) = indirect with predecrement  
( ) + = indirect with postdecrement

## 16-Bit Virtual Memory Microprocessor

SCN68010

A test operand (TST) instruction that will set the condition codes as a result of a compare of the operand with zero is also available. Test and set (TAS) is a synchronization instruction useful in multiprocessor systems. Table 6 is a summary of the integer arithmetic operations.

### Logical Operations

Logical operation instructions AND, OR, EOR, and NOT are available for all sizes of integer data operands. A similar set of immediate instructions (ANDI, ORI, and EORI) provide these logical operations with all sizes of immediate data. Table 7 is a summary of the logical operations.

**Table 7. Logical Operations**

INSTRUCTION	OPERAND SIZE	OPERATION
AND	8, 16, 32	$(Dn) \wedge (EA) \rightarrow Dn$ $(EA) \wedge (Dn) \rightarrow EA$ $(EA) \wedge \#xxx \rightarrow EA$
OR	8, 16, 32	$(Dn) \vee (EA) \rightarrow Dn$ $(EA) \vee (Dn) \rightarrow EA$ $(EA) \vee \#xxx \rightarrow EA$
EOR	8, 16, 32	$(EA) \oplus (Dy) \rightarrow EA$ $(EA) \oplus \#xxx \rightarrow EA$
NOT	8, 16, 32	$\sim(EA) \rightarrow EA$

**NOTES:**

# = immediate data  
 $\sim$  = invert  
 $\wedge$  = logical AND  
 $\vee$  = logical OR  
 $\oplus$  = logical exclusive OR

### Shift and Rotate Operations

Shift operations in both directions are provided by the arithmetic shift instructions ASR and LSL. The rotate instructions (with and without extend) available are ROXR, ROXL, ROR, and ROL. All shift and rotate operations can be performed in either registers or memory. Register shifts and rotates support all operand sizes and allow a shift count specified in a data register.

Memory shifts and rotates are for word operands only and allow only single-bit shifts or rotates.

Table 8 is a summary of the shift and rotate operations.

**Table 8. Shift and Rotate Operations**

INSTRUCTION	OPERAND SIZE	OPERATION
ASL	8, 16, 32	
ASR	8, 16, 32	
LSL	8, 16, 32	
LSR	8, 16, 32	
ROL	8, 16, 32	
ROR	8, 16, 32	
ROXL	8, 16, 32	
ROXR	8, 16, 32	



## 16-Bit Virtual Memory Microprocessor

SCN68010

**Bit Manipulation Operations**

Bit manipulation operations are accomplished using the following instructions: bit test (BTST), bit test and set (BSET), bit test and clear (BCLR), and bit test and change (BCHG). Table 9 is a summary of the bit manipulation operations. (Z is bit 2 of the status register.)

Table 9. Bit Manipulation Operations

INSTRUCTION	OPERAND SIZE	OPERATION
BTST	8, 32	$\sim$ bit of (EA) $\rightarrow$ Z
BSET	8, 32	$\sim$ bit of (EA) $\rightarrow$ Z 1 $\rightarrow$ bit of EA
BCLR	8, 32	$\sim$ bit of (EA) $\rightarrow$ Z 0 $\rightarrow$ bit of EA
BCHG	8, 32	$\sim$ bit of (EA) $\rightarrow$ Z $\sim$ bit of (EA) $\rightarrow$ bit of EA

**NOTE:**

$\sim$  = invert

**Binary Coded Decimal Operations**

Multiprecision arithmetic operations on binary coded decimal numbers are accomplished using the following instructions: add decimal with extend (ABCD), subtract decimal with extend (SBCD), and negate decimal with extend (NBCD). Table 10 is a summary of the binary coded decimal operations.

Table 10. Binary Coded Decimal Operations

INSTRUCTION	OPERAND SIZE	OPERATION
ABCD	8	$(Dx)_{10} + (Dy)_{10} + X \rightarrow Dx$ $-(Ax)_{10} + -(Ay)_{10} + X \rightarrow (Ax)$
SBCD	8	$(Dx)_{10} - (Dy)_{10} - X \rightarrow Dx$ $-(Ax)_{10} - -(Ay)_{10} - X \rightarrow (Ax)$
NBCD	8	$0 - (EA)_{10} - X \rightarrow (EA)$

**NOTES:**

- = indirect with predecrement.  
+ = indirect with postdecrement.

**Program Control Operations**

Program control operations are accomplished using a series of conditional and unconditional branch instructions and return instructions. These instructions are summarized in Table 11.

The conditional instructions provide setting and branching for the following conditions:

CC — carry clear	LS — low or same
CS — carry set	LT — less than
EQ — equal	MI — minus
F — never true	NE — not equal
GE — greater or equal	PL — plus
GT — greater than	T — always true
HI — high	VC — no overflow
LE — less or equal	VS — overflow

Table 11. Program Control Operations

INSTRUCTION	OPERATION
<b>Conditional</b>	
B <sub>CC</sub>	Branch conditionally (14 conditions) 8- and 16-bit displacement
DB <sub>CC</sub>	Test condition, decrement, and branch 16-bit displacement
S <sub>CC</sub>	Set byte conditionally (16 conditions)
<b>Unconditional</b>	
BRA	Branch always 8- and 16-bit displacement
BSR	Branch to subroutine 8- and 16-bit displacement
JMP	Jump
JSR	Jump to subroutine
<b>Returns</b>	
RTD	Return from subroutine and deallocate stack
RTR	Return and restore condition codes
RTS	Return from subroutine

# 16-Bit Virtual Memory Microprocessor

SCN68010

## System Control Operations

System control operations are accomplished by using privileged instructions, trap generating instructions, and instructions that use or modify the condition code register. These instructions are summarized in Table 12.

## SIGNAL AND BUS OPERATION DESCRIPTION

This section contains a brief description of the input and output signals. A discussion of bus operation during the various machine cycles and operations is also given.

### NOTE

The terms **assertion** and **negation** will be used extensively. This is done to avoid confusion when dealing with a mixture of "active-low" and "active-high" signals. The term **assert** or **assertion** is used to indicate that a signal is active or true, independent of whether that level is represented by a high or low voltage. The term **negate** or **negation** is used to indicate that a signal is inactive or false.

### Signal Description

The input and output signals can be functionally organized into the groups shown in Figure 8. The following paragraphs provide a brief description of the signals and a reference (if applicable) to other paragraphs that contain more detail about the function being performed.

Table 12. System Control Operations

INSTRUCTION	OPERATION
<b>Privileged</b>	
ANDI to SR	Logical AND to status register
EORI to SR	Logical EOR to status register
MOVE EA to SR	Load new status register
MOVE SR to EA	Store status register
MOVE USP	Move user stack pointer
MOVEC	Move control register
MOVES	Move alternate address space
ORI to SR	Logical OR to status register
RESET	Reset external devices
RTE	Return from exception
STOP	Stop program execution
<b>Trap Generating</b>	
CHK	Check data register against upper bounds
TRAP	Trap
TRAPV	Trap on overflow
<b>Condition Code Register</b>	
ANDI to CCR	Logical AND to condition codes
EORI to CCR	Logical EOR to condition codes
MOVE EA to CCR	Load new condition codes
MOVE CCR to EA	Store condition codes
ORI to CCR	Logical OR to condition codes

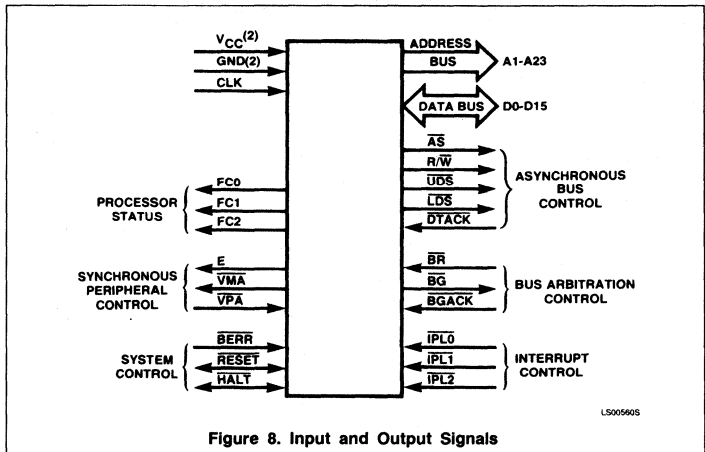

Figure 8. Input and Output Signals

## 16-Bit Virtual Memory Microprocessor

SCN68010

2

**Address Bus (A1 through A23)**

This 23-bit, unidirectional, 3-State bus is capable of addressing 8 megawords of data. It provides the address for bus operation during all cycles except CPU space cycles.

**Data Bus (D0 through D15)**

This 16-bit, bidirectional, 3-State bus is the general purpose data path. It can transmit and accept data in either word or byte length.

**Asynchronous Bus Control**

Asynchronous data transfers are handled using the following control signals: address strobe, read/write, upper and lower data strobes, and data transfer acknowledge. These signals are explained in the following paragraphs.

**Address Strobe ( $\overline{AS}$ )** — This signal indicates that there is a valid address on the address bus.

**Read/Write ( $R/\overline{W}$ )** — This signal defines the data bus transfer as a read or write cycle. The  $R/\overline{W}$  signal also works in conjunction with the data strobes as explained in the following paragraph.

**Upper and Lower Data Strobe ( $\overline{UDS}$ ,  $\overline{LDS}$ )**

— These signals control the flow of data on the data bus, as shown in Table 13. When the  $R/\overline{W}$  line is high, the processor will read from the data bus as indicated. When the  $R/\overline{W}$  line is low, the processor will write to the data bus as shown.

**Data Transfer Acknowledge ( $\overline{DTACK}$ )** —

This input indicates that the data transfer is completed. When the processor recognizes  $\overline{DTACK}$  during a read cycle, data is latched one clock cycle later and the bus cycle terminated. When  $\overline{DTACK}$  is recognized during a write cycle, the bus cycle is terminated. Refer to **Asynchronous Versus Synchronous Operation**.

**Bus Arbitration Control**

The three signals, bus request, bus grant, and bus grant acknowledge, form a bus arbitration circuit to determine which device will be the bus master device.

**Bus Request ( $\overline{BR}$ )** — This input is wire ORed with all other devices that could be bus masters. This input indicates to the processor that some other device desires to become the bus master.

**Bus Grant ( $\overline{BG}$ )** — This output indicates to all other potential bus master devices that the processor will release bus control at the end of the current bus cycle.

**Bus Grant Acknowledge ( $\overline{BGACK}$ )** — This input indicates that some other device has become the bus master. This signal should not be asserted until the following four conditions are met:

1. a bus grant has been received,

**Table 13. Data Strobe Control of Data Bus**

$\overline{UDS}$	$\overline{LDS}$	$R/\overline{W}$	D8 – D15	D0 – D7
High	High	–	No valid data	No valid data
Low	Low	High	Valid data bits 8 – 15	Valid data bits 0 – 7
High	Low	High	No valid data	Valid data bits 0 – 7
Low	High	High	Valid data bits 8 – 15	No valid data
Low	Low	Low	Valid data bits 8 – 15	Valid data bits 0 – 7
High	Low	Low	Valid data bits 0 – 7*	Valid data bits 0 – 7
Low	High	Low	Valid data bits 8 – 15	Valid data bits 8 – 15*

**NOTE:**

\*These conditions are a result of current implementation and may not appear on future devices.

2. address strobe is inactive which indicates that the microprocessor is not using the bus,
3. data transfer acknowledge is inactive which indicates that neither memory or peripherals are using the bus, and
4. bus grant acknowledge is inactive which indicates that no other device is still claiming bus mastership.

**Interrupt Control ( $\overline{IPL0}$ ,  $\overline{IPL1}$ ,  $\overline{IPL2}$ )**

These input pins indicate the encoded priority level of the device requesting an interrupt. Level seven is the highest priority while level zero indicates that no interrupts are requested. Level seven cannot be masked. The least significant bit is  $\overline{IPL0}$  and the most significant bit is  $\overline{IPL2}$ . These lines must remain stable until the processor signals interrupt acknowledge ( $\overline{FC0}$  –  $\overline{FC2}$  are all high, A4 – A23 are all high) to insure that the interrupt is recognized.

**System Control**

The system control inputs are used to either reset or halt the processor and to indicate to the processor that bus errors have occurred. The three system control inputs are explained in the following paragraphs.

**Bus Error ( $\overline{BERR}$ )** — This input informs the processor that there is a problem with the cycle currently being executed. Problems may be a result of:

1. nonresponding devices,
2. interrupt vector number acquisition failure,
3. illegal access request as determined by a memory management unit, or
4. other application dependent errors.

The bus error signal interacts with the halt signal to determine if the current bus cycle should be reexecuted or if exception processing should be performed.

Refer to **Bus Error and Halt Operation** for additional information about the interaction of the  $\overline{BERR}$  and  $\overline{HALT}$  signals.

**Reset ( $\overline{RESET}$ )** — This bidirectional signal line acts to reset (start a system initialization sequence) the processor in response to an external reset signal. An internally generated reset (result of a reset instruction) causes all external devices to be reset and the internal state of the processor is not affected. A total system reset (processor and external devices) is the result of external  $\overline{HALT}$  and  $\overline{RESET}$  signals applied at the same time. Refer to **Reset Operation** for further information.

**Halt ( $\overline{HALT}$ )** — when this bidirectional line is driven by an external device, it will cause the processor to stop at the completion of the current bus cycle. When the processor has been halted using this input, all control signals are inactive and all 3-State lines are put in their high-impedance state (refer to Table 15). Refer to **Bus Error and Halt Operation** for additional information about the interaction between the  $\overline{HALT}$  and  $\overline{BERR}$  signals.

When the processor has stopped executing instructions, due to a double bus fault condition (refer to **Double Bus Faults**), the  $\overline{HALT}$  line is driven by the processor to indicate to external devices that the processor has stopped.

**Peripheral Control**

These control signals are used to allow the interfacing of synchronous peripheral devices with the asynchronous SCN68010. These signals are explained in the following paragraphs.

**Enable (E)** — This signal is the standard enable signal common to all synchronous type peripheral devices. The period for this output is ten SCN68010 clock periods (six

## 16-Bit Virtual Memory Microprocessor

SCN68010

clocks low, four clocks high). Enable is generated by an internal ring counter which may come up in any state (i.e., at power on, it is impossible to guarantee phase relationship of E to CLK). E is a free-running clock and runs regardless of the state of the bus on the MPU.

**Valid Peripheral Address ( $\overline{VPA}$ )** — This input indicates that the device addressed is a synchronous family device and that data transfer should be synchronized with the enable (E) signal. This input also indicates that the processor should use automatic vectoring for an interrupt. Refer to **Interface with Synchronous Peripherals**.

**Valid Memory Address ( $\overline{VMA}$ )** — This output is used to indicate to synchronous peripheral devices that there is a valid address on the address bus and the processor is synchronized to enable (E). This signal only responds to a valid peripheral address ( $\overline{VPA}$ ) input which indicates that the peripheral is a synchronous family device.

**Processor Status (FC0, FC1, FC2).**

These function code outputs indicate the state (user or supervisor) and the address space currently being accessed, as shown in Table 14. The information indicated by the function code outputs is valid whenever address strobe ( $\overline{AS}$ ) is active.

**Clock (CLK)**

The clock input is a TTL-compatible signal that is internally buffered for development of the internal clocks needed by the processor. The clock input should not be gated off at any time and the clock signal must conform to minimum and maximum pulse width times.

**Signal Summary**

Table 15 is a summary of all the signals discussed in the previous paragraphs.

**Table 14. Function Code Outputs**

FUNCTION CODE OUTPUT			CYCLE TYPE
FC2	FC1	FC0	
0	0	0	Undefined, reserved*
0	0	1	User data space
0	1	0	User program space
0	1	1	Undefined, reserved*
1	0	0	Undefined, reserved*
1	0	1	Supervisor data space
1	1	0	Supervisor program space
1	1	1	CPU space

**NOTE:**

\*Address space 3 is reserved for user definition, while 0 and 4 are reserved for future use by Signetics.

**Table 15. Signal Summary**

SIGNAL NAME	MNEMONIC	INPUT/OUTPUT	ACTIVE STATE	HI-Z	
				on HALT	on BGACK
Address bus	A1 - A23	Output	High	Yes	Yes
Data bus	D0 - D15	Input/output	High	Yes	Yes
Address strobe	$\overline{AS}$	Output	Low	No	Yes
Read/write	R/ $\overline{W}$	Output	Read-High Write-Low	No No	Yes Yes
Upper and lower data strobes	$\overline{UDS}$ , $\overline{LDS}$	Output	Low	No	Yes
Data transfer acknowledge	$\overline{DTACK}$	Input	Low	-	-
Bus request	$\overline{BR}$	Input	Low	-	-
Bus grant	BG	Output	Low	No	No
Bus grant acknowledge	$\overline{BGACK}$	Input	Low	-	-
Interrupt priority level	$\overline{IPL0}$ , $\overline{IPL1}$ , $\overline{IPL2}$	Input	Low	-	-
Bus error	BERR	Input	Low	-	-
Reset	$\overline{RESET}$	Input/Output	Low	No*	No*
Halt	$\overline{HALT}$	Input/Output	Low	No*	No*
Enable	E	Output	High	No	No
Valid memory address	$\overline{VMA}$	Output	Low	No	Yes
Valid peripheral address	$\overline{VPA}$	Input	Low	-	-
Function code output	FC0, FC1, FC2	Output	High	No	Yes
Clock	CLK	Input	High	-	-
Power input	VCC	Input	-	-	-
Ground	GND	Input	-	-	-

**NOTE:**

\*Open drain

## 16-Bit Virtual Memory Microprocessor

SCN68010

2

**Bus Operation**

The following paragraphs explain control signal and bus operation during data transfer operations, bus arbitration, bus error and halt conditions, and reset operation.

**Data Transfer Operations**

Transfer of data between devices involves the following signals:

1. address bus A1 through A23,
2. data bus D0 through D15, and
3. control signals.

The address and data buses are separate parallel buses used to transfer data using an asynchronous bus structure. In all cycles, the bus master assumes responsibility for deskewing all signals it issues at both the start and end of a cycle. In addition, the bus

master is responsible for deskewing the acknowledge and data signals from the slave device.

The following paragraphs explain the read, write, and read-modify-write cycles. The indivisible read-modify-write cycle is the method used by the SCN68010 for interlocked multi-processor communications.

**Read Cycle** — During a read cycle, the processor receives data from the memory or a peripheral device. The processor reads bytes of data in all cases. If the instruction specifies a word (or long word) operation, the processor reads both upper and lower bytes simultaneously by asserting both upper and lower data strobes. When the instruction specifies byte operation, the processor uses an internal A0 bit to determine which byte to

read and then issues the data strobe required for that byte. For byte operations, when the A0 bit equals zero, the upper data strobe is issued. When the A0 bit equals one, the lower data strobe is issued. When the data is received, the processor correctly positions it internally. If  $\overline{DTACK}$ , BERR, or  $\overline{VPA}$  is not asserted for the required setup time before the falling edge of S4, a wait cycle will be inserted in the bus cycle and  $\overline{DTACK}$  will be sampled again on the falling edge of each wait cycle. The SCN68010 will continue to insert wait cycles until  $\overline{DTACK}$ , BERR, or  $\overline{VPA}$  is recognized.

A word read cycle flowchart is given in Figure 9. A byte read cycle flowchart is given in Figure 10. Read cycle timing is given in Figure 11. Figure 12 details word and byte read cycle operations.

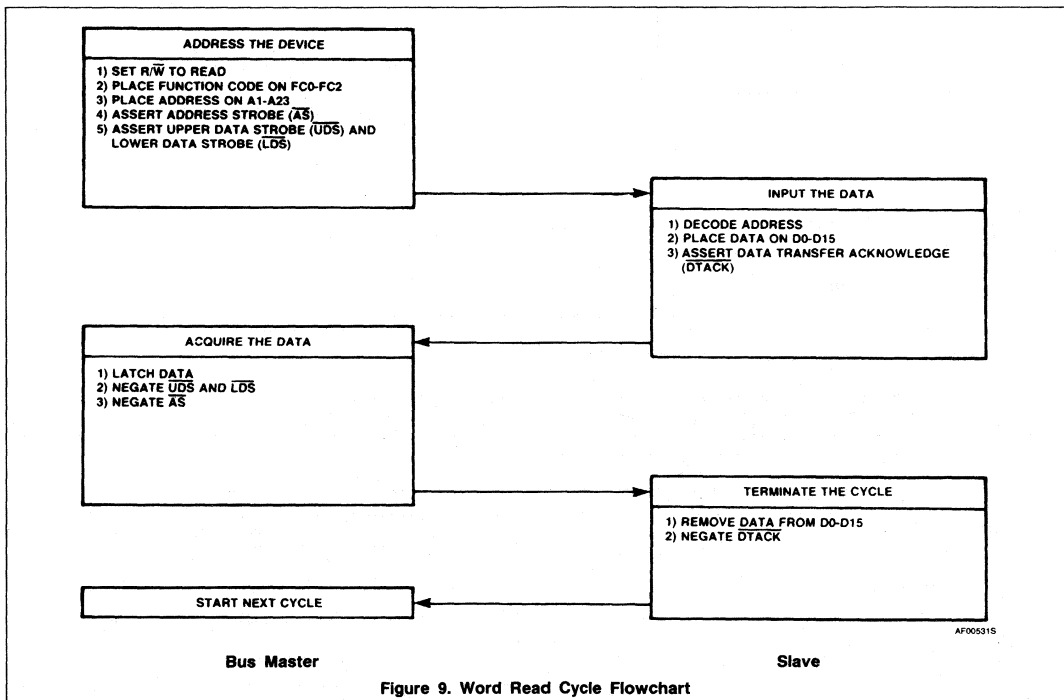
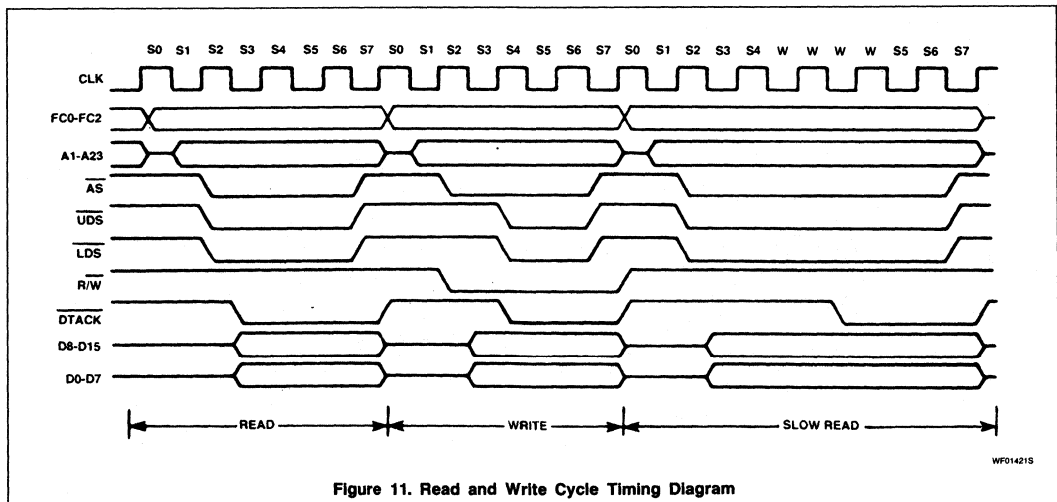
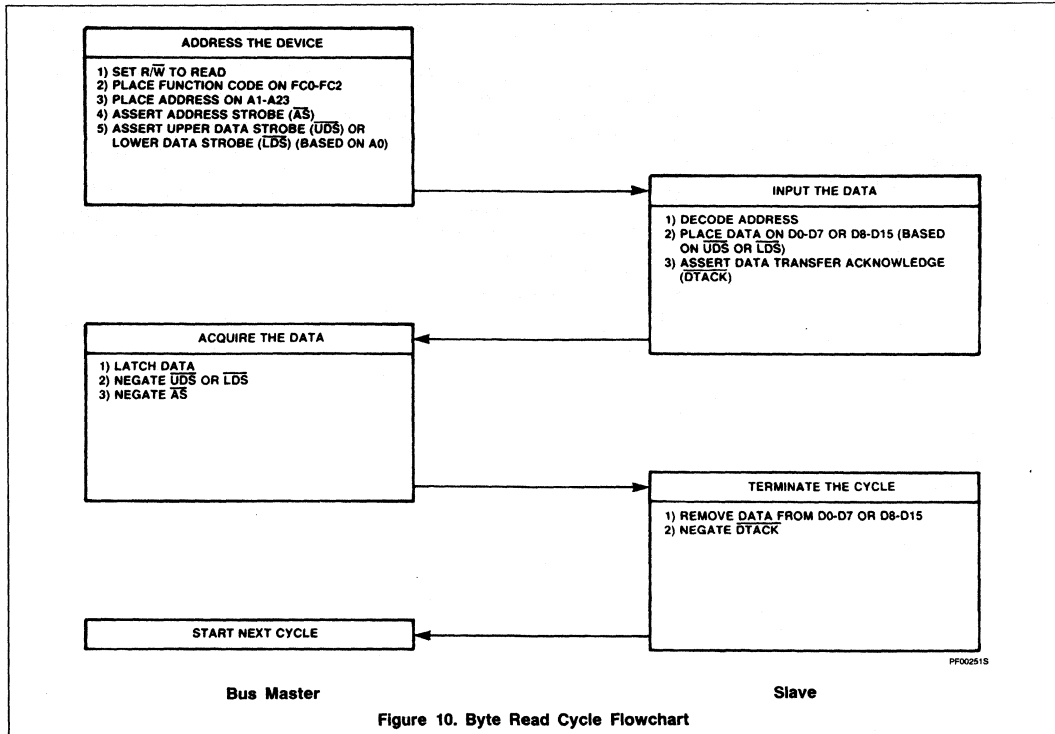

Figure 9. Word Read Cycle Flowchart

16-Bit Virtual Memory Microprocessor

SCN68010



16-Bit Virtual Memory Microprocessor

SCN68010

2

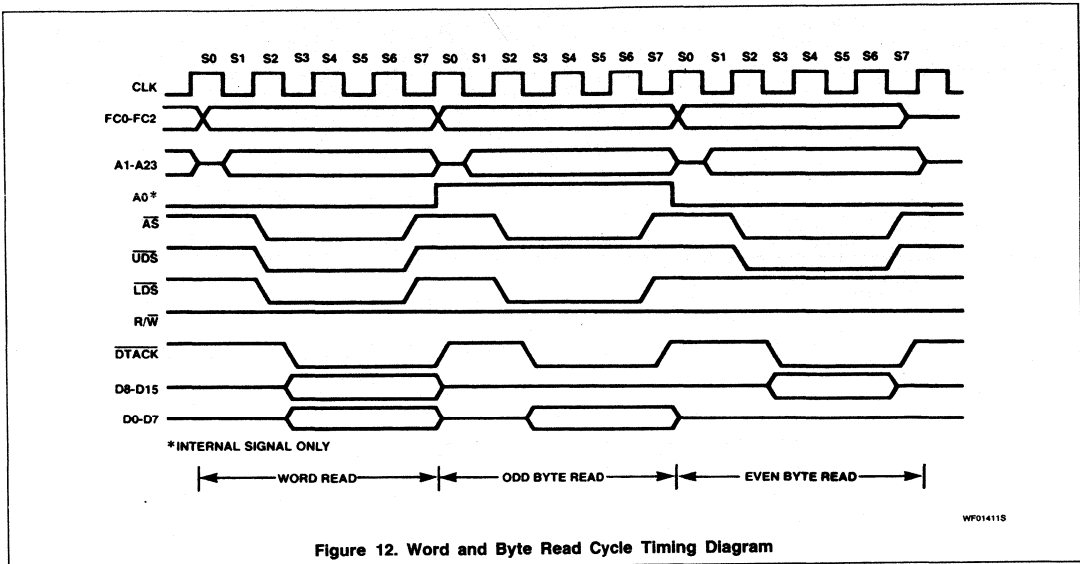

Figure 12. Word and Byte Read Cycle Timing Diagram

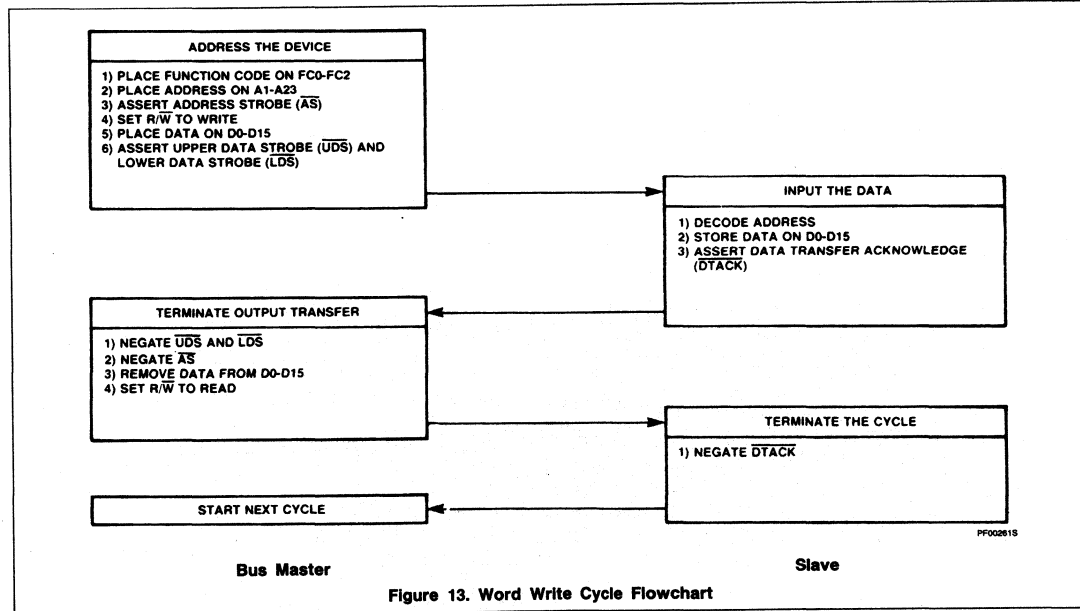

Figure 13. Word Write Cycle Flowchart

# 16-Bit Virtual Memory Microprocessor

SCN68010

**Write Cycle** — During a write cycle, the processor sends data to either the memory or a peripheral device. The processor writes bytes of data in all cases. If the instruction specifies a word operation, the processor writes both bytes. When the instruction speci-

fies a byte operation, the processor uses an internal A0 bit to determine which byte to write and then issues the data strobe required for that byte. For byte operations, when the A0 bit equals zero, the upper data strobe is issued. When the A0 bit equals one, the lower

data strobe is issued. A word write flowchart is given in Figure 13. A byte write cycle flowchart is given in Figure 14. Write cycle timing is given in Figure 11. Figure 15 details word and byte write cycle operation.

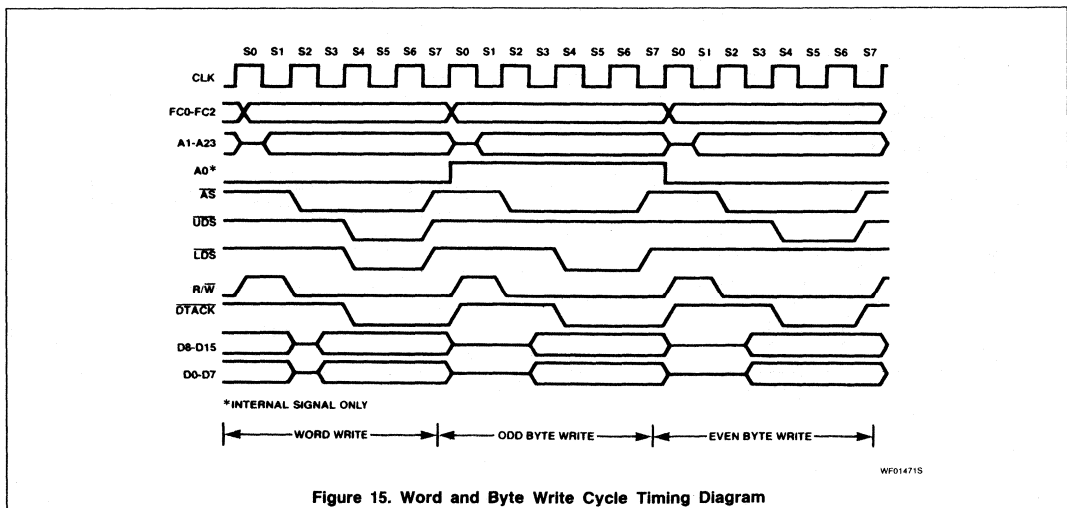
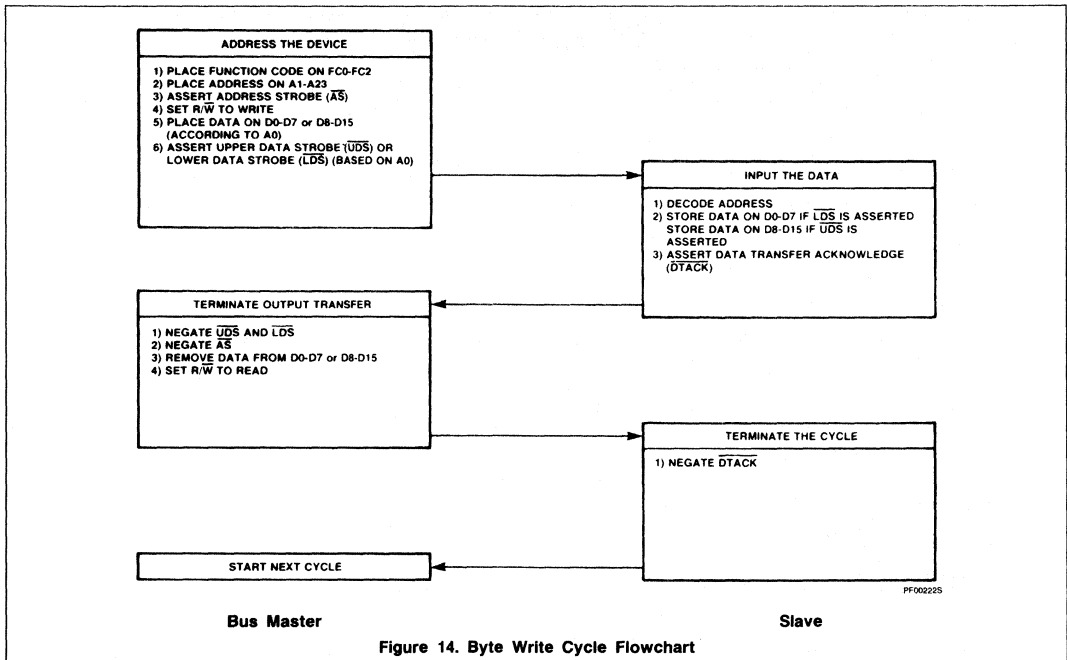



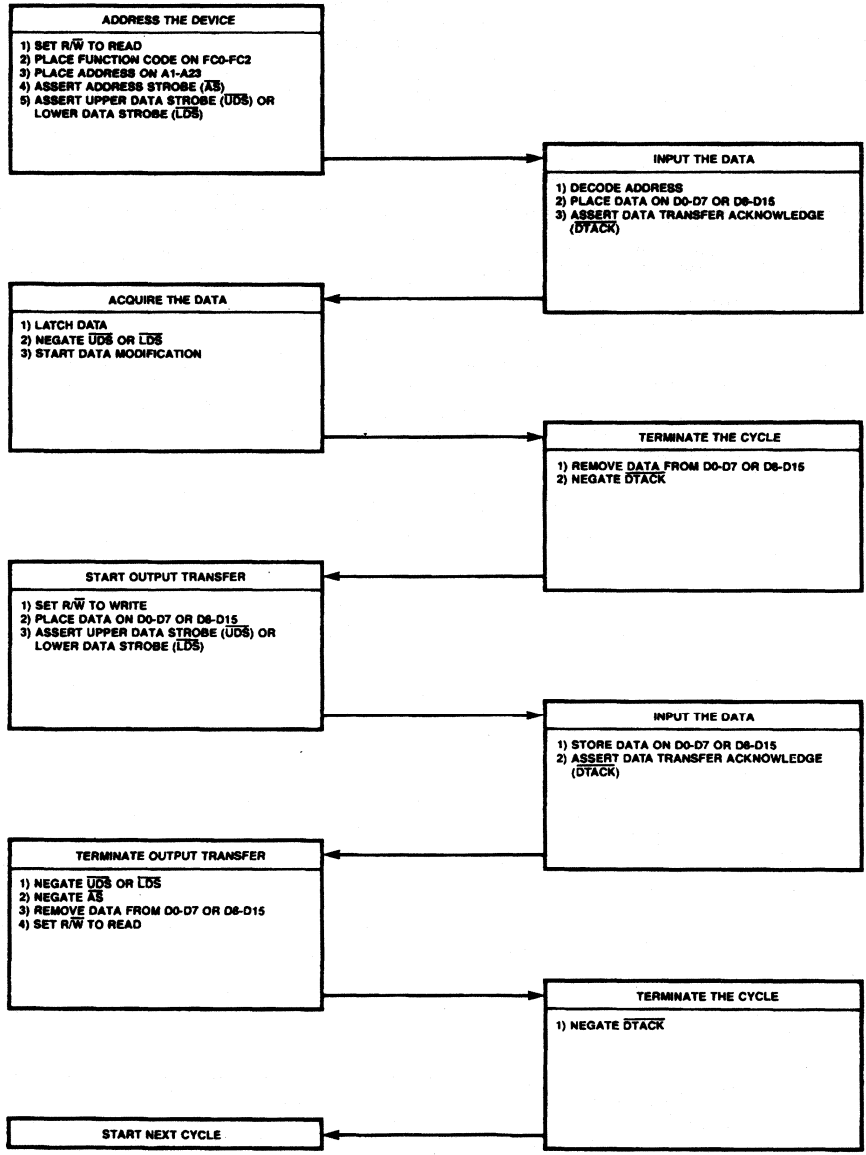

PF002715

Bus Master

Slave

Figure 16. Read-Modify-Write Cycle Flowchart



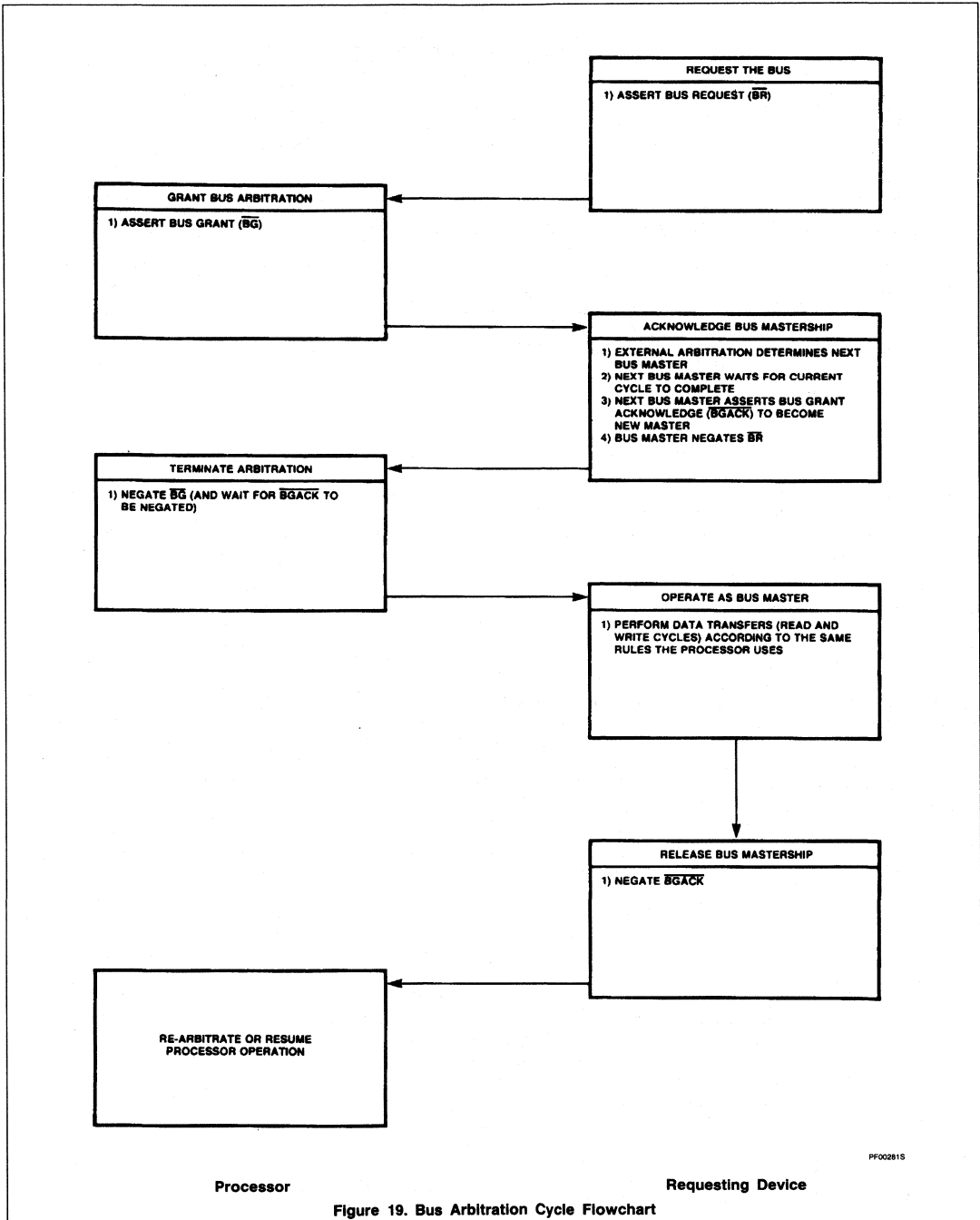

PF002815

Figure 19. Bus Arbitration Cycle Flowchart

## 16-Bit Virtual Memory Microprocessor

SCN68010

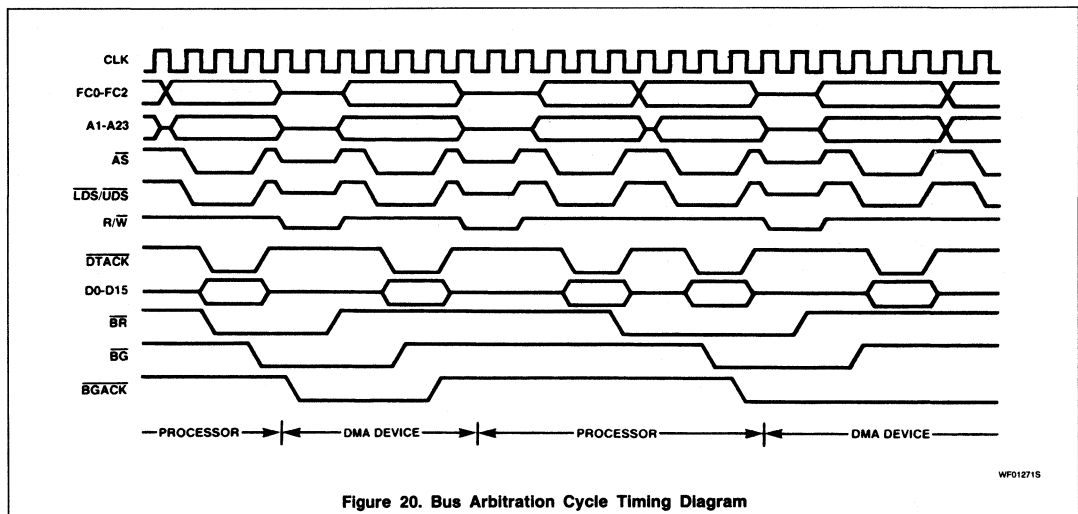

Figure 20. Bus Arbitration Cycle Timing Diagram

The timing diagram shows that the bus request is negated at the time that an acknowledge is asserted. This type of operation would be true for a system consisting of the processor and one device capable of bus mastership. In systems having a number of devices capable of bus mastership, the bus request line from each device is wire ORed to the processor. In this system, it is easy to see that there could be more than one bus request being made. The timing diagram shows that the bus grant signal is negated a few clock cycles after the transition of the acknowledge ( $\overline{BGACK}$ ) signal.

However, if bus requests are still pending, the processor will assert another bus grant within a few clock cycles after it was negated. This additional assertion of bus grant allows external arbitration circuitry to select the next bus master before the current bus master has completed its requirements. The following paragraphs provide additional information about the three steps in the arbitration process.

**Requesting the Bus** — External devices capable of becoming bus masters request the bus by asserting the bus request ( $\overline{BR}$ ) signal. This is a wire-ORed signal (although it need not be constructed from open-collector devices) that indicates to the processor that some external device requires control of the

external bus. The processor is effectively at a lower bus priority level than the external device and will relinquish the bus after it has completed the last bus cycle it has started.

When no acknowledge is received before the bus request signal goes inactive, the processor will continue processing when it detects that the bus request is inactive. This allows ordinary processing to continue if the arbitration circuitry responded to noise inadvertently.

**Receiving the Bus Grant** — The processor asserts bus grant ( $\overline{BG}$ ) as soon as possible. Normally this is immediately after internal synchronization. The only exception to this occurs when the processor has made an internal decision to execute the next bus cycle but has not progressed far enough into the cycle to have asserted the address strobe ( $\overline{AS}$ ) signal. In this case, bus grant will be delayed until  $\overline{AS}$  is asserted to indicate to external devices that a bus cycle is being executed.

The bus grant signal may be routed through a daisy-chained network or through a specific priority-encoded network. The processor is not affected by the external method of arbitration as long as the protocol is obeyed.

**Acknowledgement of Mastership** — Upon receiving a bus grant, the requesting device waits until address strobe, data transfer ac-

knowledge, and bus grant acknowledge are negated before issuing its own  $\overline{BGACK}$ . The negation of the  $\overline{AS}$  indicates that the previous master has released the bus. (While address strobe is asserted, no device is allowed to "break into" a cycle.) The negation of  $\overline{DTACK}$  indicates the previous slave has terminated its connection to the previous master. Note that in some applications data transfer acknowledge might not enter into this function. General purpose devices would then be connected such that they were only dependent on address strobe. When bus grant acknowledge is issued, the device is a bus master until it negates bus grant acknowledge. Bus grant acknowledge should not be negated until after the bus cycle(s) is (are) completed. Bus mastership is terminated at the negation of bus grant acknowledge.

The bus request from the granted device should be negated after bus grant acknowledge is asserted. If a bus request is still pending, another bus grant will be asserted within a few clocks of the negation of the bus grant. Refer to **Bus Arbitration Control**. Note that the processor does not perform any external bus cycles before it re-asserts bus grant.

16-Bit Virtual Memory Microprocessor

SCN68010

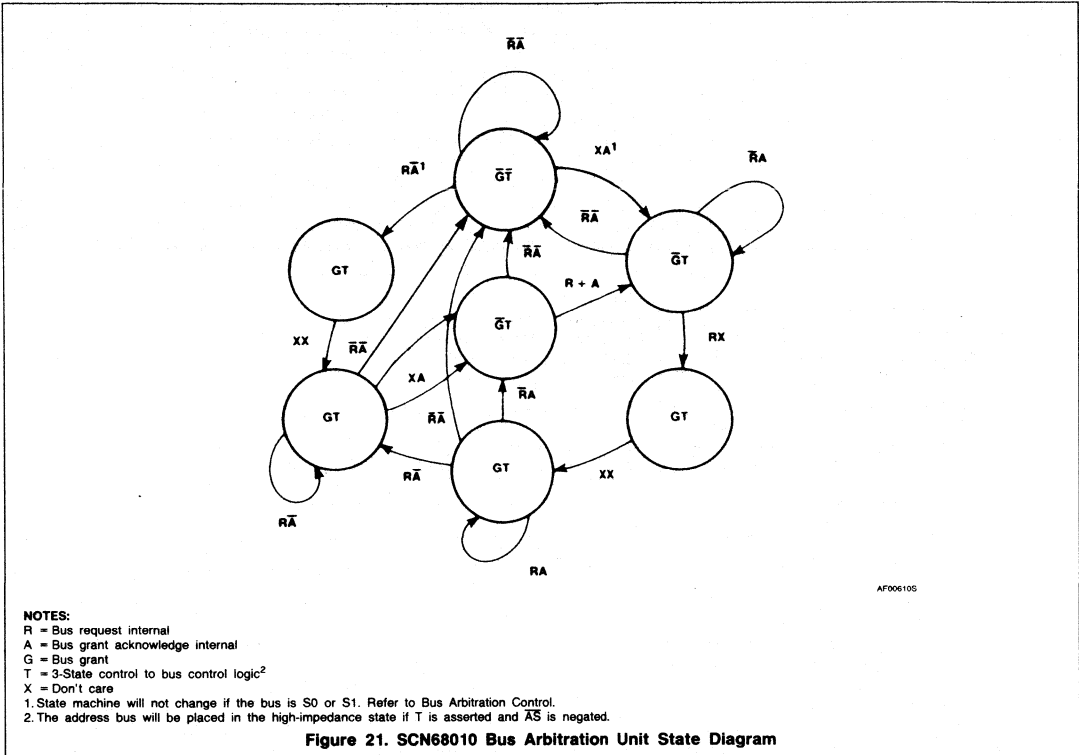

Figure 21. SCN68010 Bus Arbitration Unit State Diagram

**Bus Arbitration Control**

The bus arbitration control unit in the SCN68010 is implemented with a finite state machine. A state diagram of this machine is shown in Figure 21. All asynchronous signals to the SCN68010 are synchronized before they are used internally. This synchronization is accomplished in a maximum of one cycle of the system clock, assuming that the asynchronous input setup time (#47) has been met (see Figure 22). The input signal is sampled on the falling edge of the clock and is valid internally after the next rising edge.

As shown in Figure 21, input signals labeled R and A are internally synchronized on the bus request and bus grant acknowledge pins respectively. The bus grant output is labeled G and the internal 3-State control signal T. If T is true, the address, data, and control buses are placed in a high-impedance state when  $\overline{AS}$  is negated. All signals are shown in positive logic (active high) regardless of their true active voltage level.

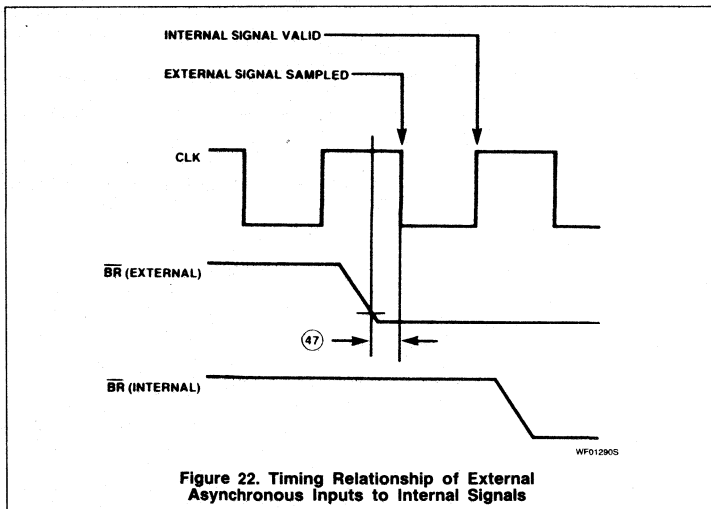

Figure 22. Timing Relationship of External Asynchronous Inputs to Internal Signals

# 16-Bit Virtual Memory Microprocessor

# SCN68010

State changes (valid outputs) occur on the next rising edge after the internal signal is valid.

A timing diagram of the bus arbitration sequence during a processor bus cycle is shown in Figure 23. The bus arbitration sequence while the bus is inactive (i.e., executing internal operations such as a multiply instruction) is shown in Figure 24.

If a bus request is made at a time when the MPU has already begun a bus cycle but  $\overline{AS}$

has not been asserted (bus state S0),  $\overline{BG}$  will not be asserted on the next rising edge. Instead,  $\overline{BG}$  will be delayed until the second rising edge following its internal assertion. This sequence is shown in Figure 25.

### Bus Error and Halt Operation

In a bus architecture that requires a handshake from an external device, the possibility exists that the handshake might not occur. Since different systems will require a different maximum response time, a bus error input is provided. External circuitry must be used to

determine the duration between address strobe and data transfer acknowledge before issuing a bus error signal. When a bus error or/and halt signal is received, the processor will initiate a bus error exception sequence or try to rerun the bus cycle.

In addition to a bus timeout indicator, the bus error input is used to indicate a page fault in a virtual memory system. When an external memory management unit detects an invalid access, a bus error is signaled to suspend execution of the current instruction.

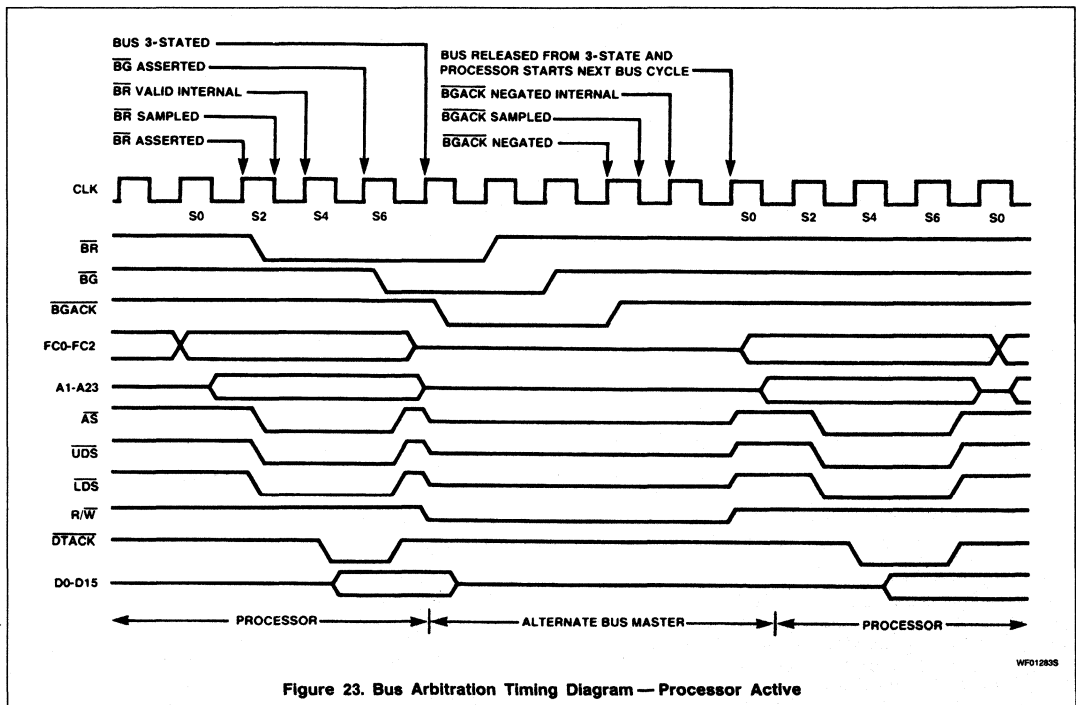

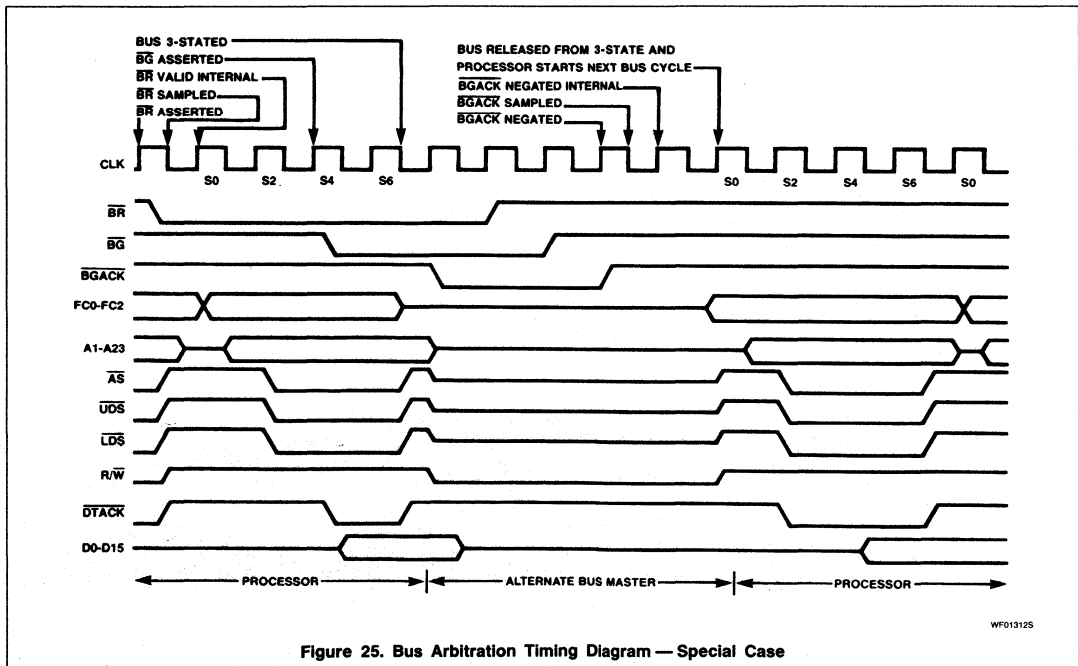
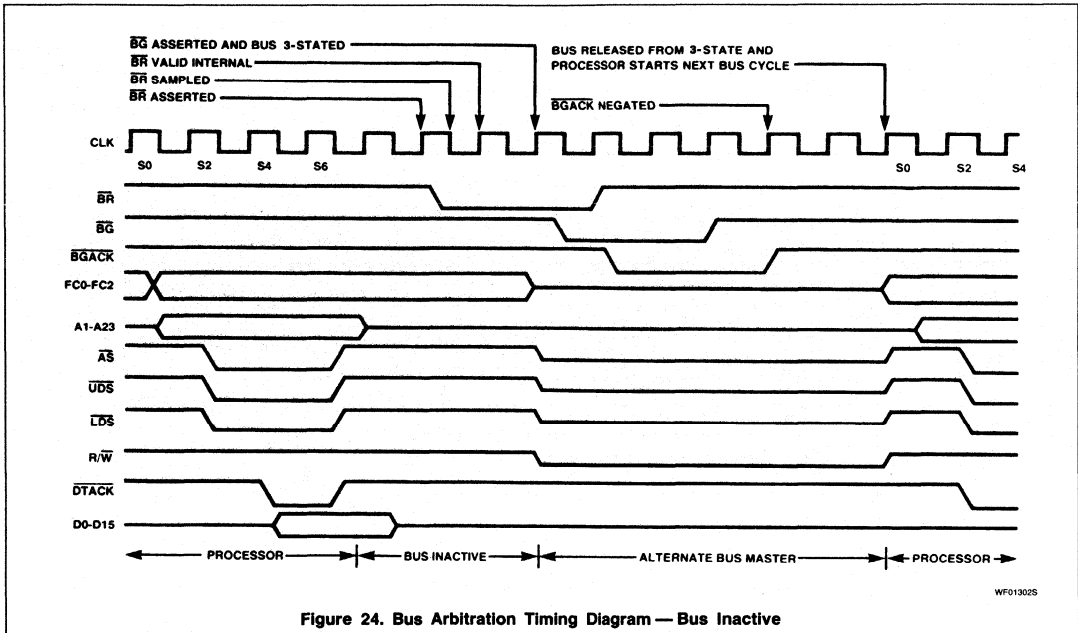

# 16-Bit Virtual Memory Microprocessor

# SCN68010

**Bus Error Operation** — When the bus error signal is used to terminate a bus cycle, the SCN68010 will enter exception processing immediately following the bus cycle. The bus error signal is recognized in either of the following cases:

1.  $\overline{DTACK}$  and  $\overline{HALT}$  are negated and  $\overline{BERR}$  is asserted.
2.  $\overline{HALT}$  and  $\overline{BERR}$  are negated and  $\overline{DTACK}$  is asserted.  $\overline{BERR}$  is then asserted within one clock cycle.

When the bus error condition is recognized, the current bus cycle will be terminated in S9

for a read cycle, a write cycle, or the read portion of a read-modify-write cycle and in S21 of the write portion of a read-modify-write cycle. As long as  $\overline{BERR}$  remains asserted, the data and address buses will be in the high-impedance state. Figures 26 and 27 show the timing diagrams for both types of bus error signals.

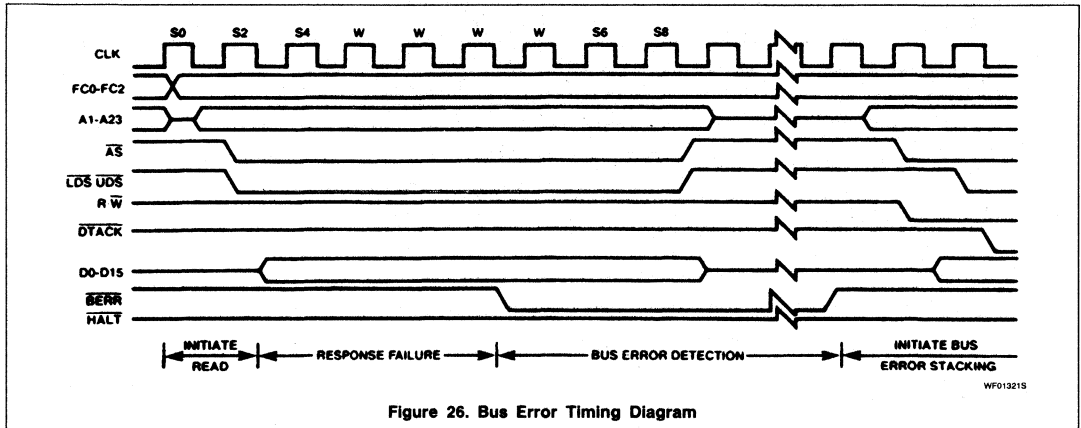

Figure 26. Bus Error Timing Diagram

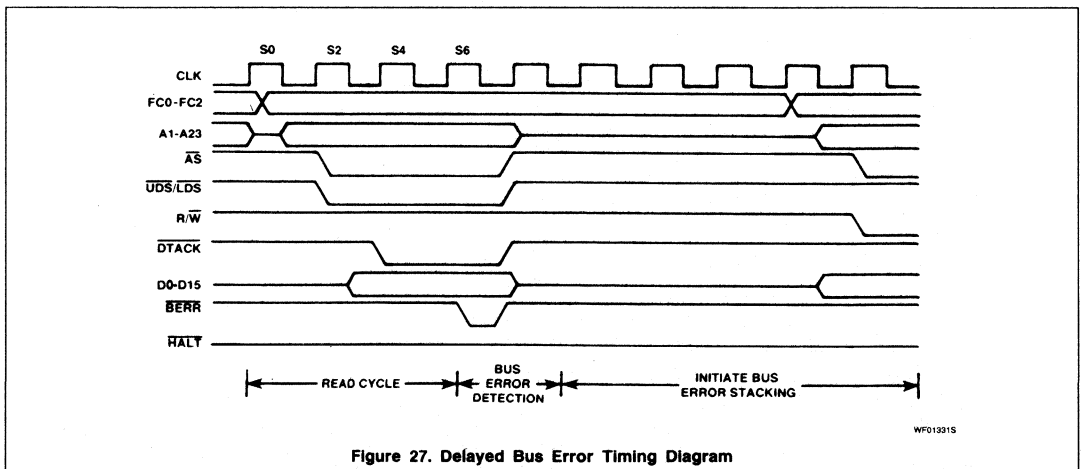

Figure 27. Delayed Bus Error Timing Diagram



## 16-Bit Virtual Memory Microprocessor

SCN68010

After the aborted bus cycle is terminated and **BERR** is negated, the SCN68010 enters exception processing for the bus error exception. During the exception processing sequence, the following information is placed on the supervisor stack:

1. Status register
2. Program counter (two words, may be up to five words past the instruction being executed)
3. Frame format and vector offset
4. Internal register information, 22 words

Note that the first four words of information are identical to the information stacked by any other exception such as an interrupt or TRAP instruction. The additional information is used by the SCN68010 to continue the execution of the suspended instruction when it is reloaded by an RTE instruction. See **Bus Error** for further details.

After the SCN68010 has placed the above information on the stack, the bus error exception vector is read from vector table entry number two (offset \$08) and placed in the program counter. The processor then resumes instruction execution.

**NOTE**

If a read-modify-write instruction is terminated with a bus error and later continued with an RTE instruction, the processor will rerun the entire cycle whether the bus error occurred on the read or the write portion of the cycle.

**Rerun Operation** — When, during a bus cycle, the processor receives a bus error signal and the halt pin is being driven by an external device, the processor enters the rerun sequence. A delayed rerun signal may be used similarly to the delayed bus error signal described above. Figures 28 and 29 are timing diagrams for both methods of rerunning the bus cycle.

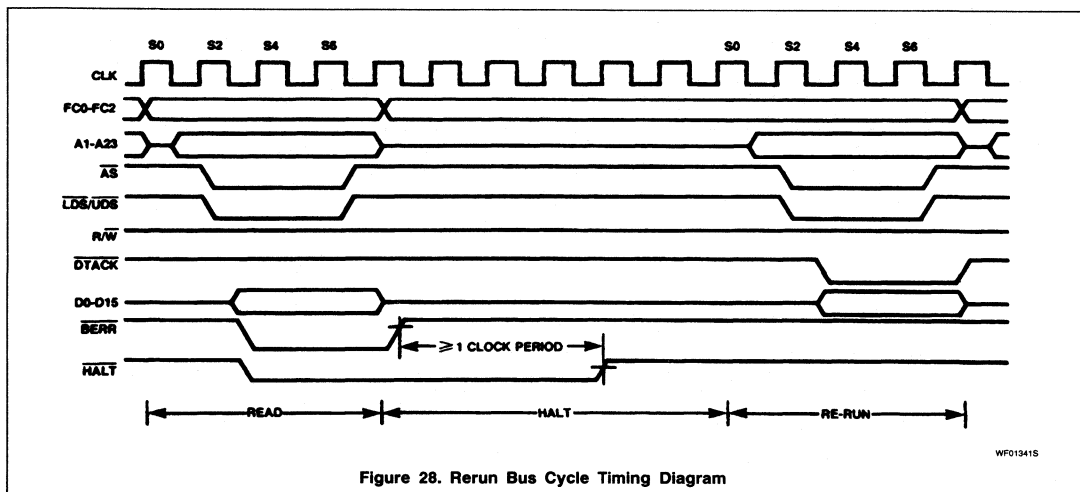

Figure 28. Rerun Bus Cycle Timing Diagram

# 16-Bit Virtual Memory Microprocessor

# SCN68010

The processor terminates the bus cycle, then puts the address and data lines in the high-impedance state. The processor remains "halted", and will not run another bus cycle until the halt signal is removed by external logic. Then the processor will rerun the previous cycle using the same function codes, the same data (for a write operation), and the same address. The bus error signal should be removed at least one clock cycle before the halt signal is removed.

**NOTE**

The processor will not rerun a read-modify-write cycle. This restriction is made to guarantee that the entire cycle runs correctly and that the write operation of a test-and-set

operation is performed without ever releasing  $\overline{AS}$ . If  $\overline{BERR}$  and  $\overline{HALT}$  are asserted during a read-modify-write bus cycle, a bus error operation results.

**Halt Operation** — The halt input signal to the SCN68010 performs a halt/run/single-step function in a similar fashion to the synchronous halt function. The halt and run modes are somewhat self explanatory in that when the halt signal is constantly active the processor "halts" (does nothing) and when the halt signal is constantly inactive the processor "runs" (does something).

This single-step mode is derived from correctly timed transitions on the halt signal input. It

forces the processor to execute a single bus cycle by entering the run mode until the processor starts a bus cycle then changing to the halt mode. Thus, the single-step mode allows the user to proceed through (and therefore debug) processor operations one bus cycle at a time.

Figure 30 details the timing required for correct single-step operations. Some care must be exercised to avoid harmful interactions between the bus error signal and the halt pin when using the single-cycle mode as a debugging tool. This is also true of interactions between the halt and reset lines since these can reset the machine.

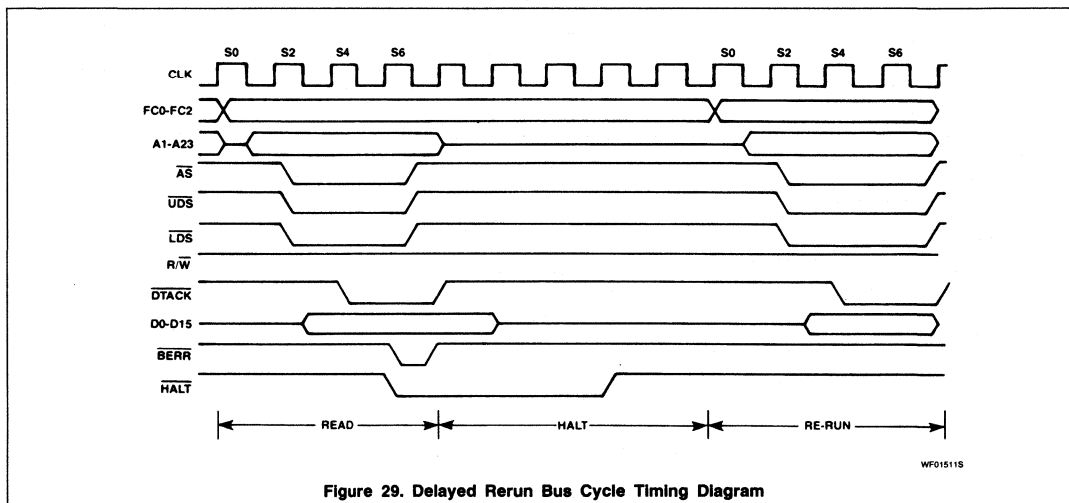

Figure 29. Delayed Rerun Bus Cycle Timing Diagram

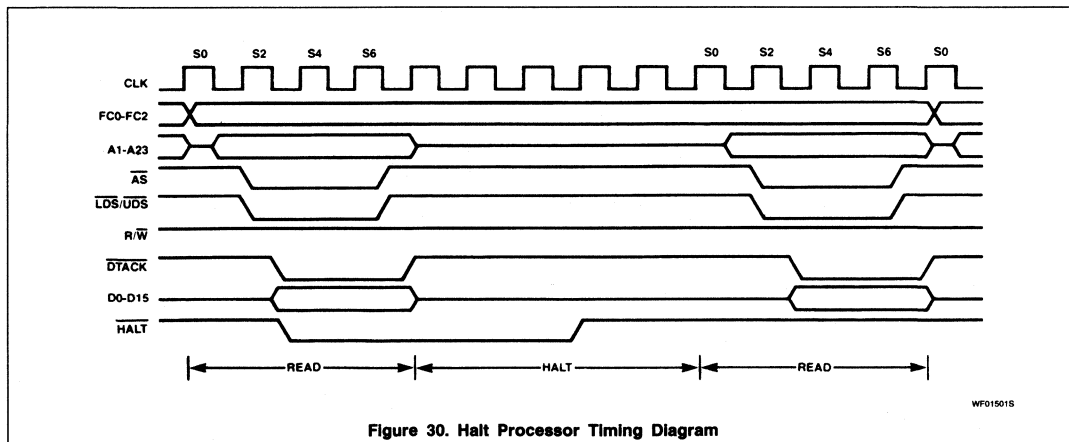

Figure 30. Halt Processor Timing Diagram

## 16-Bit Virtual Memory Microprocessor

SCN68010

When the processor completes a bus cycle after recognizing that the halt signal is active, most 3-State signals are put in the high-impedance state, these include:

1. address lines, and
2. data lines.

This is required for correct performance of the rerun bus cycle operation.

While the processor is honoring the halt request, bus arbitration performs as usual. That is, halting has no effect on bus arbitration. It is the bus arbitration function that removes the control signals from the bus.

The halt function and the hardware trace capability allow the hardware debugger to trace single bus cycles or single instructions at a time. These processor capabilities, along with a software debugging package, give total debugging flexibility.

**Double Bus Faults** — When a bus error exception occurs, the processor will attempt to stack several words containing information about the state of the machine. If a bus error exception occurs during the stacking operation, there have been two bus errors in a row. This is commonly referred to as a double bus fault. When a double bus fault occurs, the processor will halt and drive the HALT line

low. Once a bus error exception has occurred, any bus error exception occurring before the execution of the next instruction constitutes a double bus fault.

Note that a bus cycle which is rerun does not constitute a bus error exception and does not contribute to a double bus fault. Note also that this means that as long as the external hardware requests it, the processor will continue to rerun the same bus cycle.

The bus error pin also has an effect on processor operation after the processor receives an external reset input. The processor reads the vector table after a reset to determine the address to start program execution. If a bus error occurs while reading the vector table (or at any time before the first instruction is executed), the processor reacts as if a double bus fault has occurred and it halts. Only an external reset will start a halted processor.

#### Reset Operation

The reset signal is a bidirectional signal that allows either the processor or an external device to reset the system. Figure 31 is a timing diagram for the reset operation. Both the halt and reset lines must be asserted to ensure total reset of the processor in all cases.

When the reset and halt lines are driven by an external device, it is recognized as an entire system reset, including the processor. The processor responds by reading the reset vector table entry (vector number zero, address \$000000) and loads it into the supervisor stack pointer (SSP). Vector table entry number one at address \$000004 is read next and loaded into the program counter. The processor initializes the status register to an interrupt level of seven and the vector base register to \$00000000. No other registers are affected by the reset sequence.

When a reset instruction is executed, the processor drives the reset pin for 124 clock periods. In this case, the processor is trying to reset the rest of the system. Therefore, there is no effect on the internal state of the processor. All of the processor's internal registers and the status register are unaffected by the execution of a reset instruction. All external devices connected to the reset line should be reset at the completion of the reset instruction.

Asserting the  $\overline{\text{RESET}}$  and  $\overline{\text{HALT}}$  lines for ten clock cycles will cause a processor reset, except when  $V_{CC}$  is initially applied to the processor. In this case, an external reset must be applied for at least 100ms.

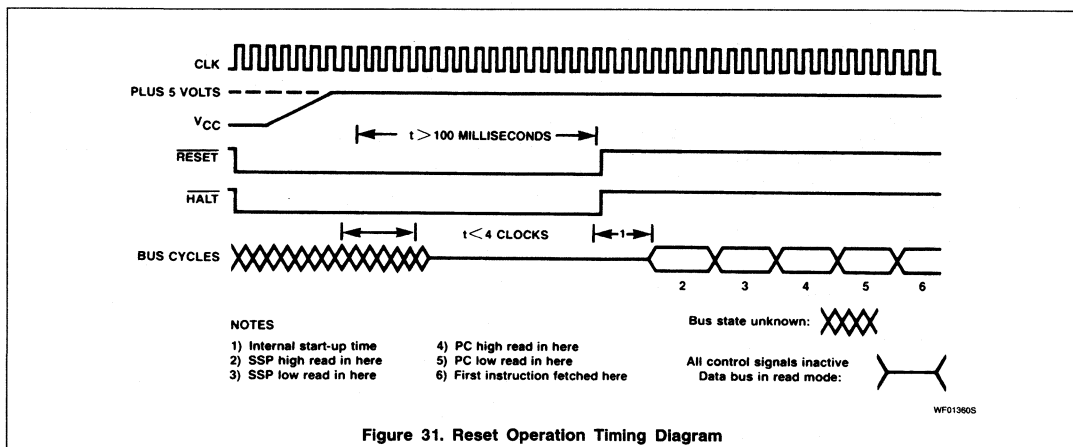

Figure 31. Reset Operation Timing Diagram

## 16-Bit Virtual Memory Microprocessor

SCN68010

**The Relationship of DTACK, BERR, and HALT**

In order to properly control termination of a bus cycle for a rerun or a bus error condition, DTACK, BERR, and HALT should be asserted and negated on the rising edge of the SCN68010 clock. This will assure that when two signals are asserted simultaneously, the required setup time (#47) for both of them will be met during the same bus state. This, or some equivalent precaution, should be designed external to the SCN68010.

The preferred bus cycle terminations may be summarized as follows (case numbers refer to Table 16):

**Normal Termination:**

DTACK is asserted, BERR and HALT remain negated (case 1).

**Halt Termination:**

HALT is asserted at same time, or before DTACK and BERR remains negated (case 2).

**Bus Error Termination:**

BERR is asserted in lieu of, at the same time, or before DTACK (case 3) or after DTACK (case 4) and HALT remains negated; BERR is negated at the same time or after DTACK.

**Rerun Termination:**

HALT and BERR are asserted in lieu of, at the same time, or before DTACK (case 5) or after DTACK (case 6); BERR is negated at the same time or after DTACK, HALT must be held at least one cycle after BERR.

Table 16 details the resulting bus cycle termination under various combinations of control signal sequences. The negation of these same control signals under several conditions is shown in Table 17. (DTACK is assumed to be negated normally in all cases; for best results, both DTACK and BERR should be negated when address strobe is negated).

**EXAMPLE A:**

A system uses a watch-dog timer to terminate accesses to unpopulated address space. The timer asserts BERR after time out (case 3).

**EXAMPLE B:**

A system uses error detection on RAM contents. Designer may:

- Delay DTACK until data verified, and return BERR and HALT simultaneously to rerun error cycle (case 5), or if valid, return DTACK (case 1).
- Delay DTACK until data verified, and return BERR at same time as DTACK if data in error (case 3).
- Return DTACK prior to data verification, as described in the next section. If data is invalid, BERR is asserted on next clock cycle (case 4).
- Return DTACK prior to data verification, if data is invalid assert BERR and HALT on

**Table 16. DTACK, BERR, and HALT Assertion Results**

CASE NO.	CONTROL SIGNAL	ASSERTED ON RISING EDGE OF STATE		RESULT
		N	N + 2	
1	DTACK BERR HALT	A NA NA	S NA X	Normal cycle terminate and continue.
2	DTACK BERR HALT	A NA A/S	S NA S	Normal cycle terminate and halt. Continue when HALT removed.
3	DTACK BERR HALT	X A NA	X S NA	Terminate and take bus error trap.
4	DTACK BERR HALT	A NA NA	X A NA	Terminate and take bus error trap.
5	DTACK BERR HALT	X A A/S	X S S	Terminate and rerun when HALT removed.
6	DTACK BERR HALT	A NA NA	X A A	Terminate and rerun when HALT removed.

**NOTES:**

N – the number of the current even bus state (e.g., S4, S6, etc.)

A – signal is asserted in this bus state

NA – signal is not asserted in this state

X – don't care

S – signal was asserted in previous state and remains asserted in this state

**Table 17. BERR and HALT Negation Results**

CONDITIONS OF TERMINATION IN TABLE 16	CONTROL SIGNAL	NEGATED ON RISING EDGE OF STATE		RESULTS – NEXT CYCLE
		N	N+2	
Bus Error	BERR HALT	• or • or	• •	Takes bus error trap.
Rerun	BERR HALT	• or •	•	Illegal sequence; usually traps to vector number 0.
Rerun	BERR HALT	•	•	Reruns the bus cycle.
Normal	BERR HALT	• • or	•	May lengthen next cycle.

**NOTE:**

• = Signal is negated in this bus state.

next clock cycle (case 6). The memory controller may then correct the RAM prior to or during the rerun.

**Asynchronous Versus Synchronous Operation****Asynchronous Operation**

To achieve clock frequency independence at a system level, the SCN68010 can be used in an asynchronous manner. This entails using

only the bus handshake lines ( $\overline{AS}$ ,  $\overline{UDS}$ ,  $\overline{LDS}$ ,  $\overline{DTACK}$ ,  $\overline{BERR}$ ,  $\overline{HALT}$  and  $\overline{VPA}$ ) to control the data transfer. Using this method,  $\overline{AS}$  signals the start of a bus cycle and the data strobes are used as a condition for valid data on a write cycle. The slave device (memory or peripheral) then responds by placing the requested data on the data bus for a read cycle or latching data on a write cycle and asserting the data transfer acknowledge signal ( $\overline{DTACK}$ ) to terminate the bus cycle. If no

## 16-Bit Virtual Memory Microprocessor

## SCN68010

2

slave responds or the access is invalid, external control logic asserts the  $\overline{\text{BERR}}$ , or  $\overline{\text{BERR}}$  and  $\overline{\text{HALT}}$ , signal to abort or rerun the bus cycle.

The  $\overline{\text{DTACK}}$  signal is allowed to be asserted before the data from a slave device is valid on a read cycle. The length of time that  $\overline{\text{DTACK}}$  may precede data is given as parameter #31 (See **AC Electrical Characteristics** for # references) and it must be met in any asynchronous system to insure that valid data is latched into the processor. Notice that there is no maximum time specified from the assertion of  $\overline{\text{AS}}$  to the assertion of  $\overline{\text{DTACK}}$ . This is because the MPU will insert wait cycles of one clock period each until  $\overline{\text{DTACK}}$  is recognized.

The  $\overline{\text{BERR}}$  signal is allowed to be asserted after the  $\overline{\text{DTACK}}$  signal is asserted.  $\overline{\text{BERR}}$  must be asserted within the time given as parameter #48 after  $\overline{\text{DTACK}}$  is asserted in any asynchronous system to insure proper operation. If this maximum delay time is violated, the processor may exhibit erratic behavior.

#### Synchronous Operation

To allow for those systems which use the system clock as a signal to generate  $\overline{\text{DTACK}}$  and other asynchronous inputs, the asynchronous input setup time is given as parameter #47. If this setup is met on an input, such as  $\overline{\text{DTACK}}$ , the processor is guaranteed to recognize that signal on the next falling edge of the system clock. However, the converse is not true — if the input signal does not meet the setup time it is not guaranteed not to be recognized. In addition, if  $\overline{\text{DTACK}}$  is recognized on a falling edge, valid data will be latched into the processor (on a read cycle) on the next falling edge provided that the data meets the setup time given as parameter #27. Given this, parameter #31 may be ignored. Note that if  $\overline{\text{DTACK}}$  is asserted, with the required setup time, before the falling edge of  $\overline{\text{S4}}$ , no wait states will be incurred and the bus cycle will run at its maximum speed of four clock periods.

In order to assure proper operation in a synchronous system when  $\overline{\text{BERR}}$  is asserted after  $\overline{\text{DTACK}}$ ,  $\overline{\text{BERR}}$  must meet the setup time parameter #27A prior to the falling edge of the clock one clock cycle after  $\overline{\text{DTACK}}$  was recognized. This setup time is critical to proper operation, and the SCN68010 may exhibit erratic behavior if it is violated.

#### NOTE

During an active bus cycle,  $\overline{\text{VPA}}$  and  $\overline{\text{BERR}}$  are sampled on every falling edge of the clock starting with  $\overline{\text{S0}}$ .  $\overline{\text{DTACK}}$  is sampled on every falling edge of the clock starting with  $\overline{\text{S4}}$  and data is latched on the falling edge of  $\overline{\text{S6}}$  during a read. The bus cycle will then be terminated in  $\overline{\text{S7}}$  except when  $\overline{\text{BERR}}$  is as-

serted in the absence of  $\overline{\text{DTACK}}$ , in which case it will terminate one clock cycle later in  $\overline{\text{S9}}$ .

#### PROCESSING STATES

This section describes the actions of the SCN68010 which are outside the normal processing associated with the execution of instructions. The functions of the bits in the supervisor portion of the status register are covered: the supervisor/user bit, the trace enable bit, and the processor interrupt priority mask. Finally, the sequence of memory references and actions taken by the processor on exception conditions are detailed.

The SCN68010 is always in one of three processing states: normal, exception, or halted. The normal processing state is that associated with instruction execution; the memory references are to fetch instructions and operands, and to store results. Two special cases of the normal state are the stopped state, which the processor enters when a STOP instruction is executed, and the loop mode, which the processor may enter when a DBcc instruction is executed. In the stopped state, no further memory references are made and in the loop mode only operand references are made.

The exception processing state is associated with interrupts, trap instructions, tracing and other exceptional conditions. The exception may be internally generated by an instruction or by an unusual condition arising during the execution of an instruction. Externally, exception processing can be forced by an interrupt, by a bus error, or by a reset. Exception processing is designed to provide an efficient context switch so that the processor may handle unusual conditions.

The halted processing state is an indication of catastrophic hardware failure. For example, if during the exception processing of a bus error another bus error occurs, the processor assumes that the system is unusable and halts. Only an external reset can restart a halted processor. Note that a processor in the stopped state is not in the halted state, nor vice versa.

#### Privilege States

The processor operates in one of two states of privilege: the "supervisor" state or the "user" state. The privilege state determines which operations are legal, are used to choose between the supervisor stack pointer and the user stack pointer in instruction references, and may be used by an external memory management device to control and translate accesses.

The privilege state is a mechanism for providing security in a computer system. Programs should access only their own code and data

areas, and ought to be restricted from accessing information which they do not need and must not modify.

The privilege mechanism provides security by allowing most programs to execute in user state. In this state, the accesses are controlled, and the effects on other parts of the system are limited. The operating system executes in the supervisor state, has access to all resources, and performs the overhead tasks for the user programs.

#### Supervisor State

The supervisor state is the higher state of privilege. For instruction execution, the supervisor state is determined by the S bit of the status register; if the S bit is asserted (high), the processor is in the supervisor state. All instructions can be executed in the supervisor state. The bus cycles generated by instructions executed in the supervisor state are classified as supervisor references. While the processor is in the supervisor privilege state, those instructions which use either the system stack pointer implicitly or address register seven explicitly access the supervisor stack pointer.

All exception processing is done in the supervisor state, regardless of the previous setting of the S bit. The bus cycles generated during exception processing are classified as supervisor references. All stacking operations during exception processing use the supervisor stack pointer.

#### User State

The user state is the lower state of privilege. For instruction execution, the user state is determined by the S bit of the status register; if the S bit is negated (low), the processor is executing instructions in the user state.

Most instructions execute the same in user state as in the supervisor state. However, some instructions which have important system effects are made privileged. User programs are not permitted to execute the STOP instruction, or the RESET instruction. To ensure that a user program cannot enter the supervisor state except in a controlled manner, the instructions which modify the whole status register are privileged. To aid in debugging programs which are to be used as operating systems, the move from status register (MOVE from SR), move to/from user stack pointer (MOVE USP), move to/from control register (MOVEC), and move alternate address space (MOVES) instructions are also privileged.

The bus cycles generated by an instruction executed in the user state are classified as user state references. This allows an external memory management device to translate the address and to control access to protected portions of the address space. While the

## 16-Bit Virtual Memory Microprocessor

SCN68010

Table 18. Bus Cycle Classification

FUNCTION CODE OUTPUT			REFERENCE CLASS
FC2	FC1	FC0	
0	0	0	Unassigned, reserved*
0	0	1	User data
0	1	0	User program
0	1	1	Unassigned, reserved*
1	0	0	Unassigned, reserved*
1	0	1	Supervisor data
1	1	0	Supervisor program
1	1	1	CPU space

**NOTE:**

\*Address space 3 is reserved for user definition, while 0 and 4 are reserved for future use by Signetics.

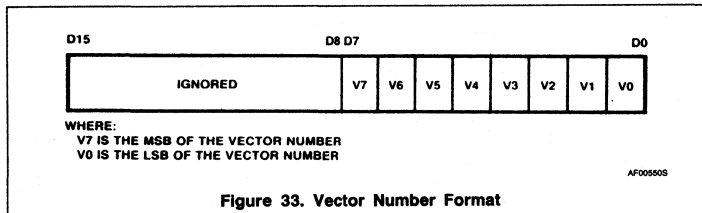
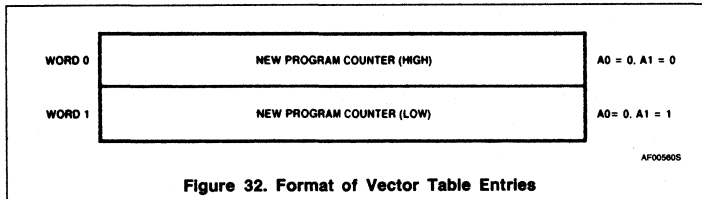

processor is in the user privilege state, those instructions which use either the system stack pointer implicitly or address register seven explicitly, access the user stack pointer.

**Privilege State Changes**

Once the processor is in the user state and executing instructions, only exception pro-

cessing can change the privilege state. During exception processing, the previous setting of the S bit of the status register is saved and the S bit is asserted, putting the processor in the supervisor state. Therefore, when instruction execution resumes at the address specified to process the exception, the processor is in the supervisor privilege state.

**Reference Classification**

When the processor makes a reference, it classifies the kind of reference being made, using the encoding on the three function code output lines. This allows external translation of addresses, control of access, and differentiation of special processor state, such as interrupt acknowledge. Table 18 lists the classification of references.

**Exception Processing**

Before discussing the details of interrupts, traps, and tracing, a general description of exception processing is in order. The processing of an exception occurs in four steps, with variations for different exception causes. During the first step, a temporary copy of the status register is made and the status register is set for exception processing. In the second step the exception vector is determined and the third step is the saving of the current processor context. In the fourth step a new context is obtained and the processor resumes instruction processing.

**Exception Vectors**

Exception vectors are memory locations from which the processor fetches the address of a routine which will handle that exception. All exception vectors are two words in length (Figure 32), except for the reset vector, which is four words. All exception vectors lie in the supervisor data space, except for the reset vector which is in the supervisor program space. A vector number is an 8-bit number which, when multiplied by four, gives the offset of an exception vector. Vector numbers are generated internally or externally, depending on the cause of the exception. In the case of interrupts, during the interrupt acknowledge bus cycle, a peripheral provides an 8-bit vector number (Figure 33) to the processor on data bus lines D0 through D7. The processor translates the vector number into a full 32-bit offset which is added to the contents of the vector base register to generate the address used to fetch the vector, as shown in Figure 34. The memory layout for exception vectors is given in Table 19.

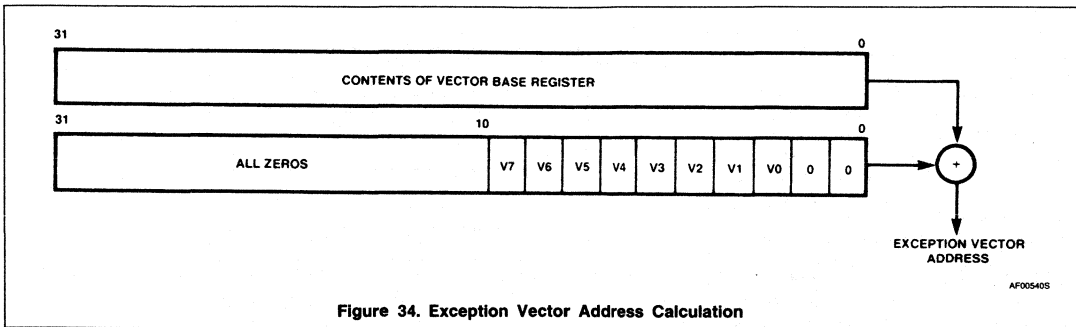

Figure 34. Exception Vector Address Calculation

As shown in Table 19, the memory layout is 512 words long (1024 bytes). It starts at offset 0 and proceeds through offset 1023. This provides 255 unique vectors; some of these are reserved for TRAPs and other system functions. Of the 255, there are 192 reserved for user interrupt vectors. However, there is no protection on the first 63 entries, so externally generated interrupt vector numbers may reference any of the exception vectors at the discretion of the system designer.

**Exception Stack Frame**

Exception processing saves the most volatile portion of the current processor context on the top of the supervisor stack. This context is organized in a format called the exception stack frame. This information always includes the status register and program counter of the processor when the exception occurred. In order to support generic handlers, the processor also places the vector offset in the exception stack frame. The format code field allows the RTE (return from exception) instruction to identify what information is on the stack so that it may be properly restored. The general form of the exception stack frame is illustrated in Figure 35. Table 20 lists the SCN68010 stack frame codes. Although some formats are peculiar to a particular S68000 family processor, the format 0000 is always legal, and indicates that just the first four words of the frame are present.

Table 20. SCN68010 Format Codes

FORMAT CODE	STACKED INFORMATION
0000	SCN68010 short format (4 words)
1000	SCN68010 long format (29 words)
All others	Unassigned, reserved

Table 19. Exception Vector Table

VECTOR NUMBER(S)	OFFSET			ASSIGNMENT
	DEC	HEX	SPACE	
0	0	000	SP	Reset: initial SSP
—	4	004	SP	Reset: initial PC
2	8	008	SD	Bus error
3	12	00C	SD	Address error
4	16	010	SD	Illegal instruction
5	20	014	SD	Zero divide
6	24	018	SD	CHK instruction
7	28	01C	SD	TRAPV instruction
8	32	020	SD	Privilege violation
9	36	024	SD	Trace
10	40	028	SD	Line 1010 emulator
11	44	02C	SD	Line 1111 emulator
12*	48	030	SD	(Unassigned, reserved)
13*	52	034	SD	(Unassigned, reserved)
14	56	038	SD	Format error
15	60	03C	SD	Uninitialized interrupt vector
16 – 23*	64	04C	SD	(Unassigned, reserved)
	95	05F		—
24	96	060	SD	Spurious interrupt
25	100	064	SD	Level 1 interrupt autovector
26	104	068	SD	Level 2 interrupt autovector
27	108	06C	SD	Level 3 interrupt autovector
28	112	070	SD	Level 4 interrupt autovector
29	116	074	SD	Level 5 interrupt autovector
30	120	078	SD	Level 6 interrupt autovector
31	124	07C	SD	Level 7 interrupt autovector
32 – 47	128	080	SD	TRAP instruction vectors
	191	0BF		—
48 – 63*	192	0C0	SD	(Unassigned, reserved)
	255	0FF		—
64 – 255	256	100	SD	User interrupt vectors

**NOTE:**

\*Vector numbers 12, 13, 16 through 23, and 48 through 63 are reserved for future enhancements by Signetics. No user peripheral devices should be assigned these numbers.

## 16-Bit Virtual Memory Microprocessor

SCN68010

**Kinds of Exceptions**

Exceptions can be generated by either internal or external causes. The externally generated exceptions are the interrupts, bus error, and reset requests. The interrupts are requests from peripheral devices for processor action while the bus error and reset inputs are used for access control and processor restart. The internally generated exceptions come from instructions, or from address errors or tracing. The trap (TRAP), trap on overflow (TRAPV), check data register against upper bounds (CHK), and divide (DIV) instructions all can generate exceptions as part of their instruction execution. In addition, illegal instructions, word or long word fetches from odd addresses, and privilege violations cause exceptions. Tracing behaves like a very high-priority internally-generated interrupt after each instruction execution.

**Exception Processing Sequence**

Exception processing occurs in four identifiable steps. In the first step, an internal copy is made of the status register. After the copy is made, the S bit is asserted, putting the processor into the supervisor privilege state. Also, the T bit is negated which will allow the exception handler to execute unhindered by tracing. For the reset and interrupt exceptions, the interrupt priority mask is also updated.

In the second step, the vector number of the exception is determined. For interrupts, the vector number is obtained by a processor fetch classified as an interrupt acknowledge. For all other exceptions, internal logic provides the vector number. This vector number is then used to generate the offset of the exception vector and is added to the vector base register.

The third step is to save the current processor status, except for the reset exception. The exception stack frame is created at the top of the supervisor stack. The current program counter value, the saved copy of the status register, and the format/offset word are written into the stack frame. The program counter value stacked usually points to the next unexecuted instruction; however, for bus error and address error, the value stacked for the program counter is unpredictable, and may be incremented by up to five words from the address of the instruction which caused the error. Group 1 and 2 exceptions (see **Multiple Exceptions**) use a short format exception stack frame (format = 0000). Additional information defining the current context is stacked for the bus error and address error exceptions.

The last step is the same for all exceptions. The new program counter value is fetched from the exception vector table. The processor then resumes instruction execution. The

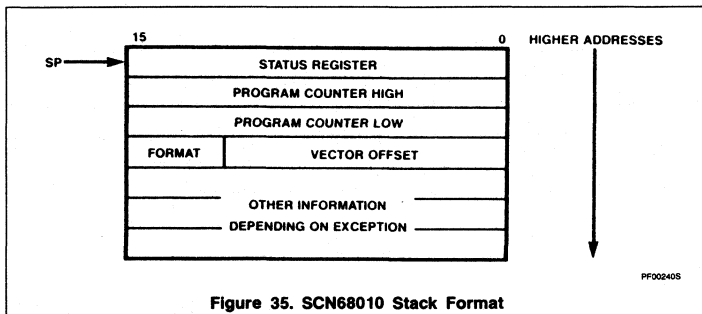

Figure 35. SCN68010 Stack Format

instruction at the address given in the exception vector is fetched, and normal instruction decoding and execution is started.

**Multiple Exceptions**

These paragraphs describe the processing which occurs when multiple exceptions arise simultaneously. Exceptions can be grouped according to their occurrence and priority. The group 0 exceptions are reset, bus error, and address error. These exceptions cause the instruction currently being executed to be aborted and the exception processing to commence within two clock cycles. The group 1 exceptions are trace and interrupt, as well as the privilege violations and illegal instructions. These exceptions allow the current instruction to execute to completion, but pre-empt the execution of the next instruction by forcing exception processing to occur (privilege violations and illegal instructions are detected when they are the next instruction to be executed). The group 2 exceptions occur as part of the normal processing of instructions. The TRAP, TRAPV, CHK, and zero divide exceptions are in this group. For these exceptions, the normal execution of an instruction may lead to exception processing.

Group 0 exceptions have highest priority, while group 2 exceptions have lowest priority. Within group 0, reset has highest priority, followed by address error and then bus error. Within group 1, trace has priority over external interrupts, which in turn takes priority over illegal instruction and privilege violation. Since only one instruction can be executed at a time, there is no priority relation within group 2.

The priority relation between two exceptions determines which is taken, or taken first, if the conditions for both arise simultaneously. Therefore, if a bus error occurs during a TRAP instruction, the bus error takes precedence, and the TRAP instruction processing is suspended. In another example, if an interrupt request occurs during the execution of an instruction while the T bit is asserted,

the trace exception has priority, and is processed first. Before instruction processing resumes, however, the interrupt exception is also processed, and instruction processing commences finally in the interrupt handler routine. A summary of exception grouping and priority is given in Table 21.

**Exception Processing in Detail**

Exceptions have a number of sources and each exception has processing which is peculiar to it. The following paragraphs detail the sources of exceptions, how each arises, and how each is processed.

**Reset**

The reset input provides the highest exception level. The processing of the reset signal is designed for system initiation, and recovery from catastrophic failure. Any processing in progress at the time of the reset is aborted and cannot be recovered. The processor is forced into the supervisor state, the trace state is forced off, and the processor interrupt priority mask is set to level seven. The vector base register is set to \$00000000 and the vector number is internally generated to reference the reset exception vector at location 0 in the supervisor program space. Because no assumptions can be made about the validity of register contents, in particular the supervisor stack pointer, neither the program counter nor the status register is saved. The address contained in the first two words of the reset exception vector is fetched as the initial supervisor stack pointer, and the address in the last two words of the reset exception vector is fetched as the initial program counter. Finally, instruction execution is started at the address in the program counter. The power-up/restart code should be pointed to by the initial program counter.

The reset instruction does not cause loading of the reset vector, but does assert the reset line to reset external devices. This allows the software to reset the system to a known state and then continue processing with the next instruction.



## 16-Bit Virtual Memory Microprocessor

SCN68010

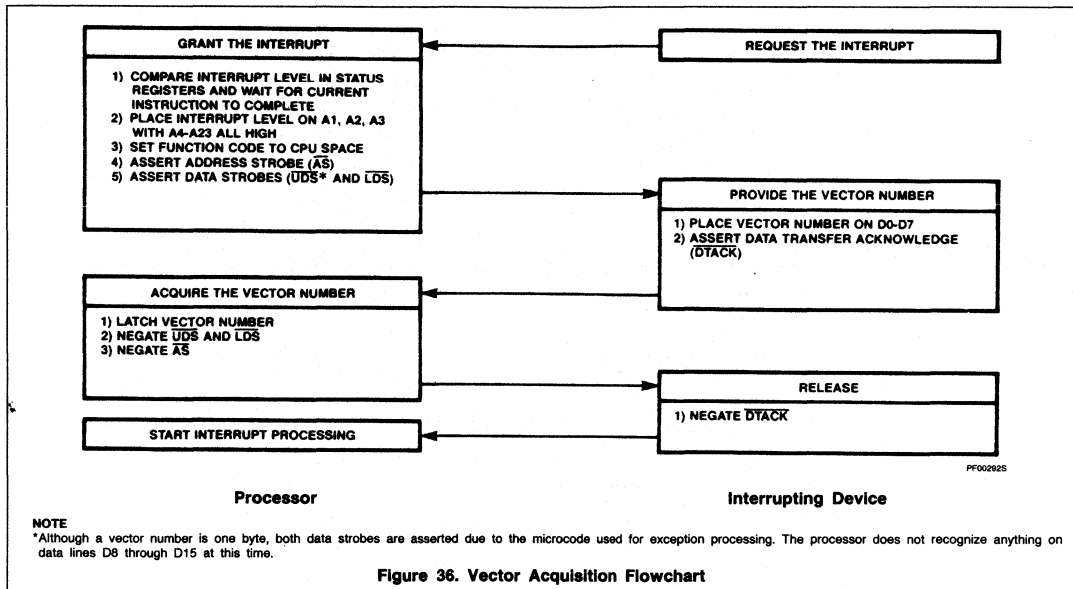
**Interrupts**

Seven levels of interrupt priorities are provided. Devices may be chained externally within interrupt priority levels, allowing an unlimited number of peripheral devices to interrupt the processor. Interrupt priority levels are numbered from one to seven, level seven being the highest priority. The status register contains a 3-bit mask which indicates the current processor priority, and interrupts are inhibited for all priority levels less than or equal to the current processor priority.

An interrupt request is made to the processor by encoding the interrupt request level on the interrupt request lines; a zero indicates no interrupt request. Interrupt requests arriving at the processor do not force immediate exception processing, but are made pending. Pending interrupts may cause exception processing to start at the end of an instruction depending on the current processor priority level. If the priority of the pending interrupt is lower than or equal to the current processor priority, execution continues with the next instruction and the interrupt exception processing is postponed. (The recognition of level seven is slightly different, as explained in the following paragraph.)

If the priority of the pending interrupt is greater than the current processor priority, the exception processing sequence is started. A copy of the status register is saved, the

**Table 21. Exception Grouping and Priority**

GROUP	EXCEPTION	PROCESSING
0	Reset address error bus error	Exception processing begins within two clock cycles
1	Trace interrupt illegal privilege	Exception processing begins before the next instruction
2	TRAP, TRAPV, CHK, zero divide format error	Exception processing is started by normal instruction execution

privilege state is set to supervisor state, tracing is suppressed, and the processor priority level is set to the level of the interrupt being acknowledged. The processor fetches the vector number from the interrupting device, classifying the reference as an interrupt acknowledge and displaying the level number of the interrupt being acknowledged on the address bus. If external logic requests automatic vectoring, the processor internally generates a vector number which is determined by the interrupt level number. If external logic indicates a bus error, the interrupt is taken to be spurious, and the generated vector number references the spurious interrupt vector. The processor then proceeds with the usual exception processing, saving the format/off-

set word, program counter, and status register on the supervisor stack. The offset value in the format/offset word is the externally supplied or internally generated vector number multiplied by four. The format will be all zeros. The saved value of the program counter is the address of the instruction which would have been executed had the interrupt not been present. The content of the interrupt vector whose vector number was previously obtained is fetched and loaded into the program counter, and normal instruction execution commences in the interrupt handling routine. A flowchart for the interrupt acknowledge sequence is given in Figure 36, a timing diagram is given in Figure 37, and the interrupt processing sequence is shown in Figure 38.

16-Bit Virtual Memory Microprocessor

SCN68010

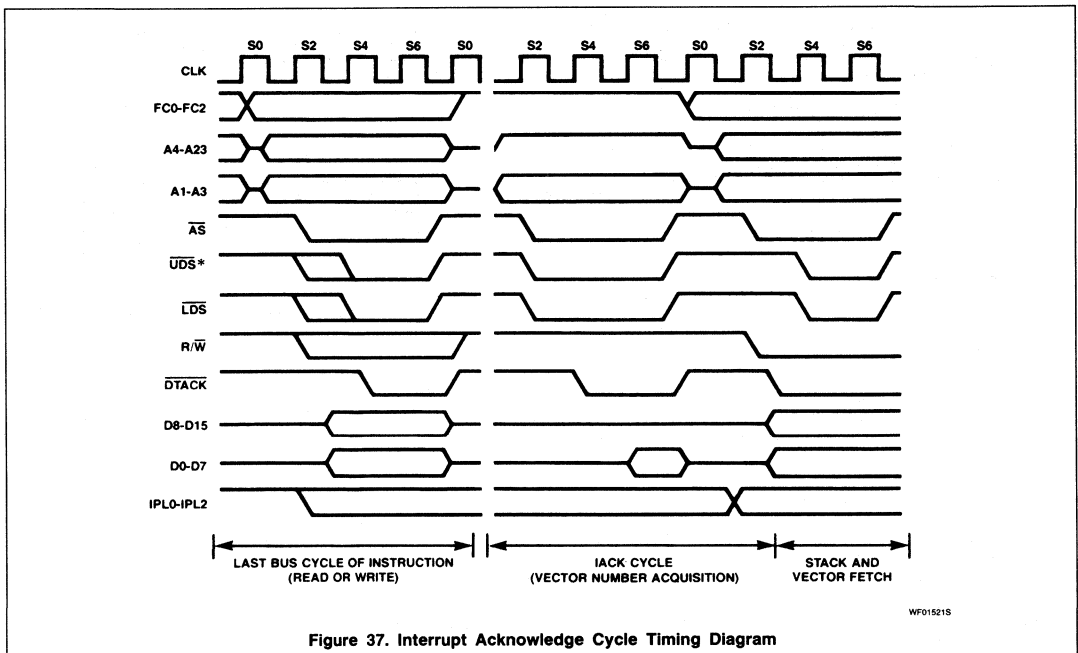

Figure 37. Interrupt Acknowledge Cycle Timing Diagram

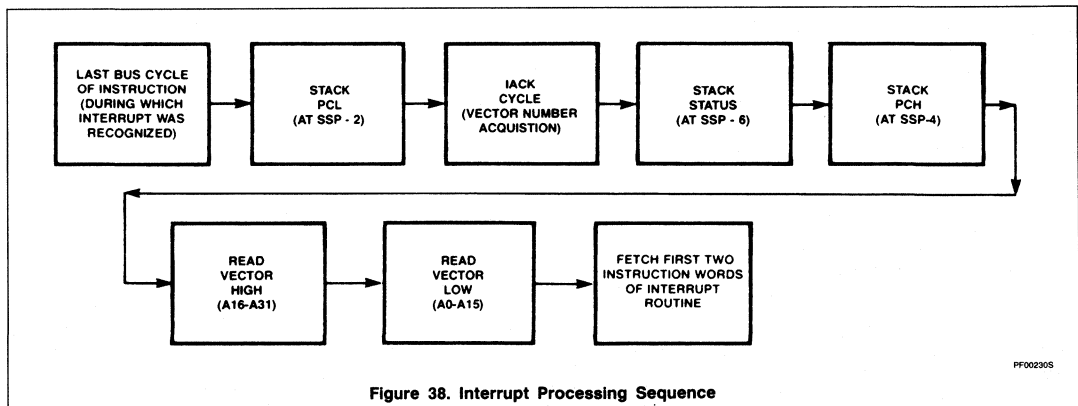

Figure 38. Interrupt Processing Sequence

## 16-Bit Virtual Memory Microprocessor

SCN68010

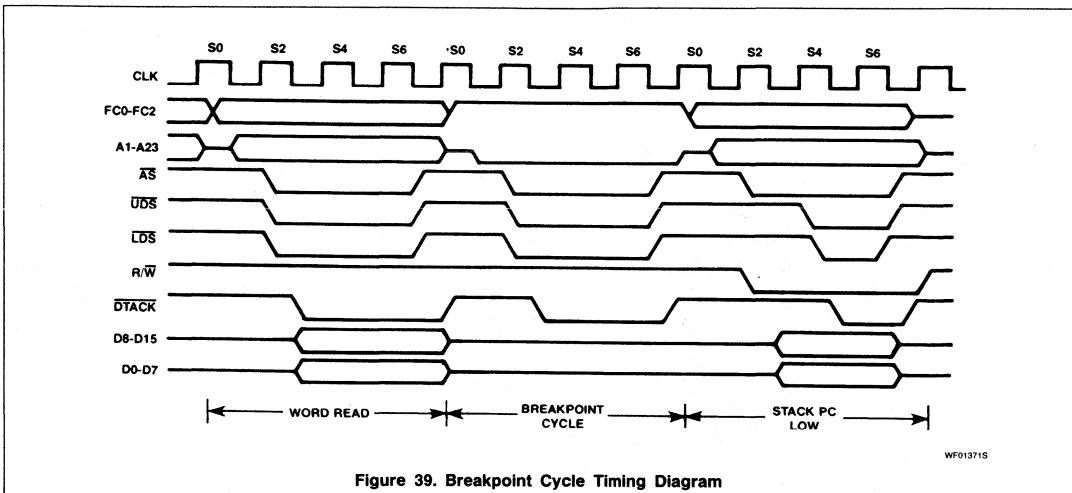

Figure 39. Breakpoint Cycle Timing Diagram

Priority level seven is a special case. Level seven interrupts cannot be inhibited by the interrupt priority mask, thus providing a "non-maskable interrupt" capability. An interrupt is generated each time the interrupt request level changes from some lower level to level seven. Note that a level seven interrupt may still be caused by the level comparison if the request level is a seven and the processor priority is set to a lower level by an instruction.

#### Uninitialized Interrupt

An interrupting device asserts  $\overline{VPA}$ ,  $\overline{BERR}$ , or provides an interrupt vector number and asserts  $\overline{DTACK}$  during an interrupt acknowledge cycle by the SCN68010. If the vector register has not been initialized, the responding S68000 family peripheral will provide vector number 15, the uninitialized interrupt vector. This provides a uniform way to recover from a programming error.

#### Spurious Interrupt

If during the interrupt acknowledge cycle no device responds by asserting  $\overline{DTACK}$  or  $\overline{VPA}$ ,  $\overline{BERR}$  should be asserted to terminate the vector acquisition. The processor separates the processing of this error from bus error by forming a short format exception stack and

fetching the spurious interrupt vector instead of the bus error vector. The processor then proceeds with the usual exception processing.

#### Instruction Traps

Traps are exceptions caused by instructions. They arise either from processor recognition of abnormal conditions during instruction execution, or from use of instructions whose normal behavior is trapping.

Some instructions are used specifically to generate traps. The TRAP instruction always forces an exception and is useful for implementing supervisor calls for user programs. The TRAPV and CHK instructions force an exception if the user program detects a runtime error, which may be an arithmetic overflow or a subscript out of bounds.

The signed divide (DIVS) and unsigned divide (DIVU) instructions will force an exception if a division operation is attempted with a divisor of zero.

#### Illegal and Unimplemented Instructions

Illegal instruction is the term used to refer to any of the word bit patterns which are not the bit patterns of the first word of a legal

SCN68010 instruction. During instruction execution, if such an instruction is fetched, an illegal instruction exception occurs. Signetics reserves the right to define instructions whose opcodes may be any of the illegal instructions. Three bit patterns will always force an illegal instruction trap on all S68000 family compatible microprocessors. They are: \$4AFA, \$4AFB, and \$4AFC. Two of the patterns, \$4AFA and \$4AFB, are reserved for Signetics system products. The third pattern, \$4AFC, is reserved for customer use.

In addition to the previously defined illegal instruction opcodes, the SCN68010 defines eight breakpoint illegal instructions with the bit patterns \$4848-\$484F. These instructions cause the processor to enter illegal instruction exception processing as usual, but a breakpoint bus cycle is executed before the stacking operations are performed as shown in Figure 39. The processor does not accept or send any data during this cycle. Whether the breakpoint cycle is terminated with a  $\overline{DTACK}$ ,  $\overline{BERR}$ , or  $\overline{VPA}$  signal, the processor will continue with the illegal instruction processing. The purpose of this cycle is to provide a software breakpoint that will signal external hardware when it is executed.

## 16-Bit Virtual Memory Microprocessor

SCN68010

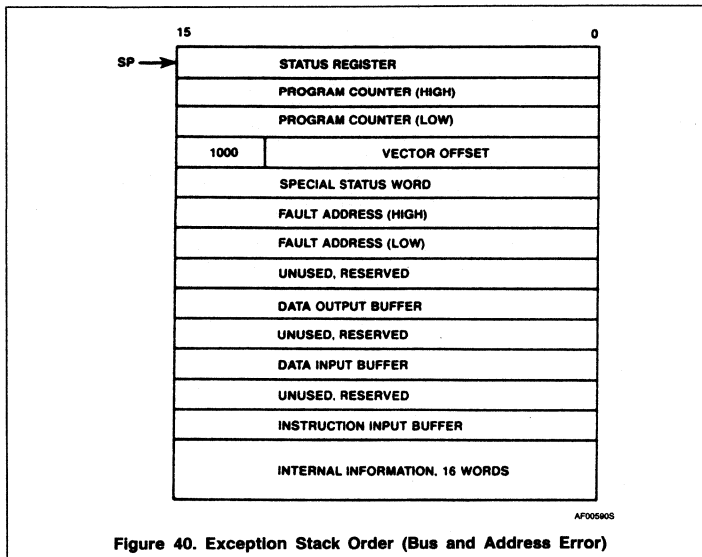

Figure 40. Exception Stack Order (Bus and Address Error)

Word patterns with bits 12 – 15 equaling 1010 or 1111 are distinguished as unimplemented instructions and separate exception vectors are given to these patterns to permit efficient emulation. This facility allows the operating system to detect program errors, or to emulate unimplemented instructions, such as the 68881 floating-point coprocessor instructions, in software.

#### Privilege Violations

In order to provide system security, various instructions are privileged. An attempt to execute one of the privileged instructions while in the user state will cause an exception. The privileged instructions are:

AND immediate to SR	MOVE USP
EOR immediate to SR	OR immediate to SR
MOVE to SR	RESET
MOVE from SR	RTE
MOVEC	STOP
MOVES	

#### Tracing

To aid in program development, the SCN68010 includes a facility to allow instruction-by-instruction tracing. In the trace state, after each instruction is executed an exception is forced, allowing a debugging program to monitor the execution of the program under test.

The trace facility uses the T bit in the supervisor portion of the status register. If the T bit is negated (off), tracing is disabled, and instruc-

tion execution proceeds from instruction to instruction as normal. If the T bit is asserted (on) at the beginning of the execution of an instruction, a trace exception will be generated as the execution of that instruction is completed. If the instruction is not executed, either because an interrupt is taken, or the instruction is illegal or privileged, the trace exception does not occur. The trace exception also does not occur if the instruction is aborted by a reset, bus error, or address error exception. If the instruction is indeed executed and an interrupt is pending on completion, the trace exception is processed before the interrupt exception. If, during the execution of the instruction an exception is forced by that instruction, the forced exception is processed before the trace exception.

As an extreme illustration of the above rules, consider the arrival of an interrupt during the execution of a TRAP instruction while tracing is enabled. First the trap exception is processed, then the trace exception, and finally the interrupt exception. Instruction execution resumes in the interrupt handler routine.

#### Bus Error

Bus error exceptions occur when external logic terminates a bus cycle with a bus error signal. Whether the processor was doing instruction or exception processing, that processing is terminated, and the processor immediately begins exception processing. However, if a bus error occurs during excep-

tion processing for a bus error, address error, or reset, the processor detects a double bus fault and halts. When exception processing is completed, instruction execution continues at the address contained in exception vector table entry two, at offset \$008.

Exception processing for a bus error follows a slightly different sequence than the sequence for group 1 and 2 exceptions. In addition to the four steps executed during exception processing for all other exceptions, 22 words of additional information are placed on the stack. This additional information describes the internal state of the processor at the time of the bus error and is reloaded by the RTE instruction to continue the instruction that caused the error. Figure 40 shows the order of the stacked information.

The value of the saved program counter does not necessarily point to the instruction that was executing when the bus error occurred, but may be advanced by up to five words. This is due to the prefetch mechanism on the SCN68010 that always fetches a new instruction word as each previously fetched instruction word is used (see **Instruction Prefetch**). However, enough information is placed on the stack for the bus error exception handler routine to determine why the bus fault occurred. This additional information includes the address that was being accessed, the function codes for the access, whether it was a read or a write, and what internal register was included in the transfer. The fault address can be used by an operating system to determine what virtual memory location is needed so that the requested data can be brought into physical memory. The RTE instruction is then used to reload the processor's internal state at the time of the fault, the faulted bus cycle will then be rerun and the suspended instruction completed. If the faulted bus cycle was a read-modify-write, the entire cycle will be rerun whether the fault occurred during the read or the write operation.

An alternate method of handling a bus error is to complete the faulted access in software. In order to use this method, use of the special status word, the instruction input buffer, the data input buffer, and the data output buffer image is required. The format of the special status word is shown in Figure 41. If the bus cycle was a write, the data output buffer image should be written to the fault address location using the function code contained in the special status word. If the cycle was a read, the data at the fault address location should be written to the images of the data input buffer, instruction input buffer, or both according to the DF and IF bits.<sup>1</sup> In addition,

<sup>1</sup>If the faulted access was a byte operation, the data should be moved from or to the least-significant byte of the data output or input buffer images unless the HB bit is set. This condition will only occur if a MOVEP instruction caused the fault during the transfer of bits 8 – 15 of a word or long word or bits 24 – 31 of a long word.

# 16-Bit Virtual Memory Microprocessor

SCN68010

2

for read-modify-write cycles, the status register image must be properly set to reflect the read data if the fault occurred during the read portion of the cycle and the write operation (i.e., setting the most significant bit of the memory location) must also be performed. This is because the entire read-modify-write cycle is assumed to have been completed by software. Once the cycle has been completed by software, the RR bit in the special status word is set to indicate to the processor that it should not rerun the cycle when the RTE instruction is executed. If the rerun flag is set when an RTE instruction executes, the SCN68010 still reads all of the information from the stack.

### Address Error

Address error exceptions occur when the processor attempts to access a word or long word operand or an instruction at an odd address. The effect is much like an internally generated bus error, so that the bus cycle is aborted, and the processor begins exception processing. After exception processing commences, the sequence is the same as that for bus error including the information that is stacked, except that the vector offset refers to the address error exception vector. If an address error occurs during exception processing for a bus error, address error, or reset, the processor detects a double bus fault and halts.

As shown in Figure 42, an address error will execute a short bus cycle followed by exception processing. This short bus cycle is similar to a normal read or write cycle, except that the data strobes are not asserted and no external signals are used to terminate the cycle. During an address error bus cycle, AS is asserted to indicate that the SCN68010 will drive the address bus (thus allowing for proper operation in a multiple bus master system). Note that data strobes are not

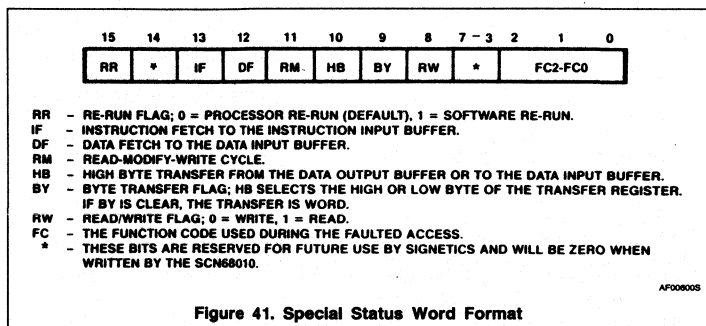

Figure 41. Special Status Word Format

asserted allowing for address error detection and memory protection.

Since the address error exception stacks the same information that is stacked by a bus error exception, it is possible to use the RTE instruction to continue execution of the suspended instruction. However, if the software rerun flag is not set, the fault address will be used when the cycle is rerun and another address error exception will occur. Therefore, the user must be certain that the proper corrections have been made to the stack image and user registers before attempting to continue the instruction. With proper software handling, the address error exception handler could emulate word or long word accesses to odd addresses if desired.

### Return From Exception

In addition to returning from any exception handler routine, the RTE instruction is used to resume the execution of a suspended instruction by restoring all of the temporary register and control information stored during a bus error and returning to the normal processing state. For the RTE instruction to execute properly, the stack must contain valid and

accessible data. The RTE instruction checks for data validity in two ways; first, by checking the format/offset word for a valid stack format code, and second, if the format code indicates the long stack format, the long stack data is checked for validity as it is loaded into the processor. In addition, the data is checked for accessibility when the processor starts reading the long data. Because of these checks, the RTE instruction executes as follows:

1. Determine the stack format. This step is the same for any stack format and consists of reading the status register, program counter, and format/offset word. If the format code indicates a short stack format, execution continues at the new program counter address. If the format code is not one of the SCN68010 defined stack format codes, exception processing starts for a format error.
2. Determine data validity. For a long stack format, the SCN68010 will begin to read the remaining stack data, checking for validity of the data. The only word checked for validity is the first of the 16 internal information words (SP + 26)

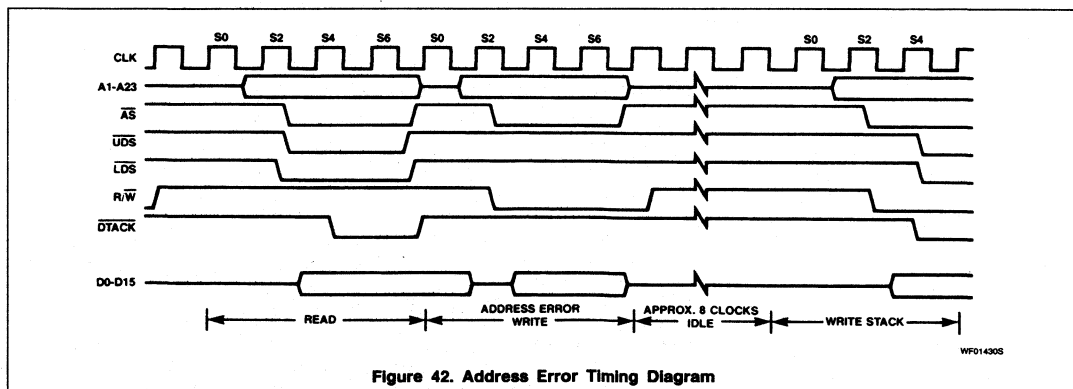

Figure 42. Address Error Timing Diagram

## 16-Bit Virtual Memory Microprocessor

SCN68010

shown in Figure 40. This word contains a processor version number in bits 10 through 13, that must match the version number of the SCN68010 that is attempting to read the data. This validity check is used to insure that in dual processor systems, the data will be properly interpreted by the RTE instruction if the two processors are of different versions. If the version number is incorrect for this processor, the RTE instruction will be aborted and exception processing will begin for a format error exception. Since the stack pointer is not updated until the RTE instruction has successfully read all of the stack data, a format error occurring at this point will not stack new data over the previous bus error stack information.

- Determine data accessibility. If the long stack data is valid, the SCN68010 performs a read from the last word (SP + 56)

of the long stack to determine data accessibility. If this read is terminated normally, the processor assumes that the remaining words on the stack frame are also accessible. If a bus error is signaled before or during this read, a bus error exception is taken as usual. After this read, the processor must be able to load the remaining data without receiving a bus error; therefore, if a bus error occurs on any of the remaining stack reads, the SCN68010 treats this as a double bus fault and enters the halted state.

### INTERFACE WITH SYNCHRONOUS PERIPHERALS

To interface the synchronous peripherals with the asynchronous SCN68010, the processor modifies its bus cycle to meet the synchronous cycle requirements whenever a syn-

chronous device address is detected. This is possible since both processors use memory mapped I/O. Figure 43 is a flowchart of the interface operation between the processor and synchronous devices.

#### Data Transfer Operation

Three signals on the processor provide the synchronous interface. They are: enable (E), valid memory address ( $\overline{VMA}$ ), and valid peripheral address ( $\overline{VPA}$ ). Enable corresponds to the E or phase 2 signal in existing synchronous systems. The bus frequency is one tenth of the incoming SCN68010 clock frequency. The timing of E allows 1MHz peripherals to be used with an 8MHz SCN68010. Enable has a 60/40 duty cycle; that is, it is low for six input clocks and high for four input clocks. This duty cycle allows the processor to do successive  $\overline{VPA}$  accesses on successive E pulses.

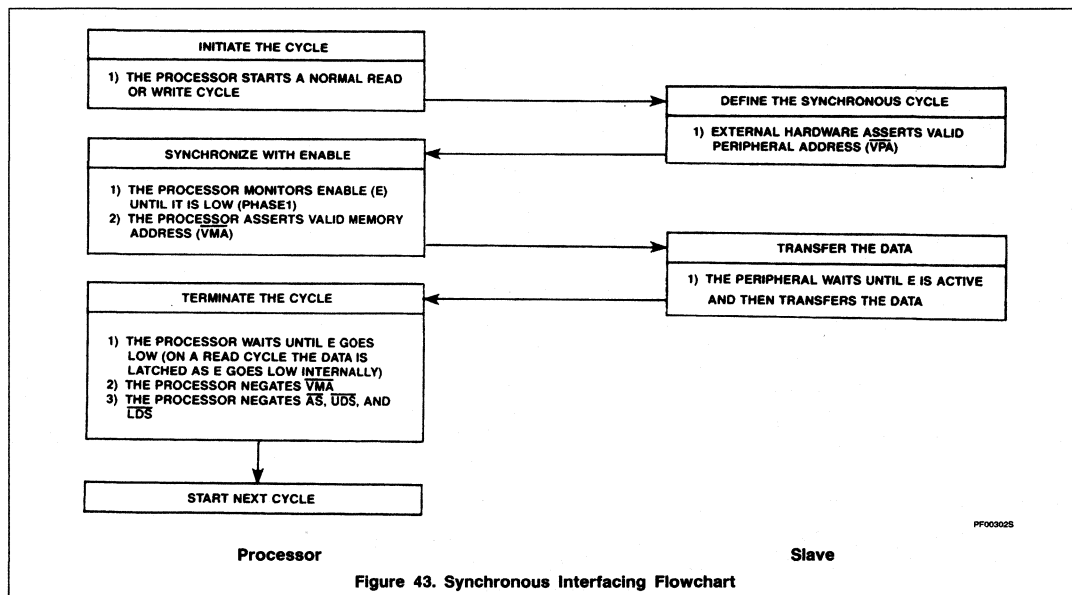

Figure 43. Synchronous Interfacing Flowchart

## 16-Bit Virtual Memory Microprocessor

SCN68010

Synchronous cycle timing is given in Figure 44. At state zero (S0) in the cycle, the address bus is in the high-impedance state. A function code is asserted on the function code output lines. One-half clock later, in state 1, the address bus is released from the high-impedance state.

During state 2, the address strobe ( $\overline{AS}$ ) is asserted to indicate that there is a valid address on the address bus. If the bus cycle is a read cycle, the upper and/or lower data strobes are also asserted in state 2. If the bus cycle is a write cycle, the read/write ( $R/\overline{W}$ ) signal is switched to low (write) during state 2. One-half clock later, in state 3, the write data is placed on the data bus, and in state 4 the data strobes are issued to indicate valid data on the data bus. The processor now inserts wait states until it recognizes the assertion of  $\overline{VPA}$ .

The  $\overline{VPA}$  input signals the processor that the address on the bus is the address of a synchronous device (or an area reserved for synchronous devices) and that the bus should conform to the phase 2 transfer characteristics of the synchronous bus. Valid peripheral address is derived by decoding the address bus, conditioned by the address strobe. Chip select for the synchronous peripherals should be derived by decoding the address bus conditioned by  $\overline{VMA}$ .

After recognition of  $\overline{VPA}$ , the processor assures that the enable (E) is low, by waiting if necessary, and subsequently asserts  $\overline{VMA}$  two clock cycles before E goes high.  $\overline{VMA}$  is then used as part of the chip select equation of the peripheral. This ensures that the synchronous peripherals are selected and deselected at the correct time. The peripheral now runs its cycle during the high portion of the E signal. Figures 44 and 45 depict the best and worst case synchronous cycle timing; this cycle length is dependent strictly upon when  $\overline{VPA}$  is asserted in relationship to the E clock.

If we assume that external circuitry asserts  $\overline{VPA}$  as soon as possible after the assertion of  $\overline{AS}$ , then  $\overline{VPA}$  will be recognized as being asserted on the falling edge of S4. In this case, no "extra" wait cycles will be inserted prior to the recognition of  $\overline{VPA}$  asserted and only the wait cycles inserted to synchronize with the E clock will determine the total length of the cycle. In any case, the synchronization delay will be some integral number of clock cycles within the following two extremes:

1. Best Case —  $\overline{VPA}$  is recognized as being asserted on the falling edge three clock

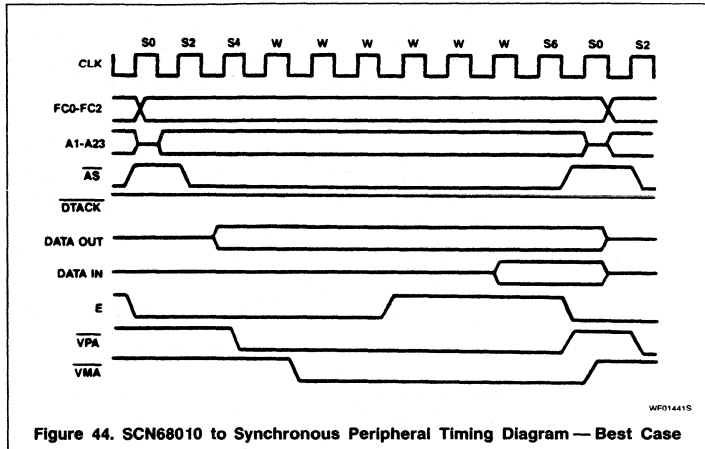

Figure 44. SCN68010 to Synchronous Peripheral Timing Diagram — Best Case

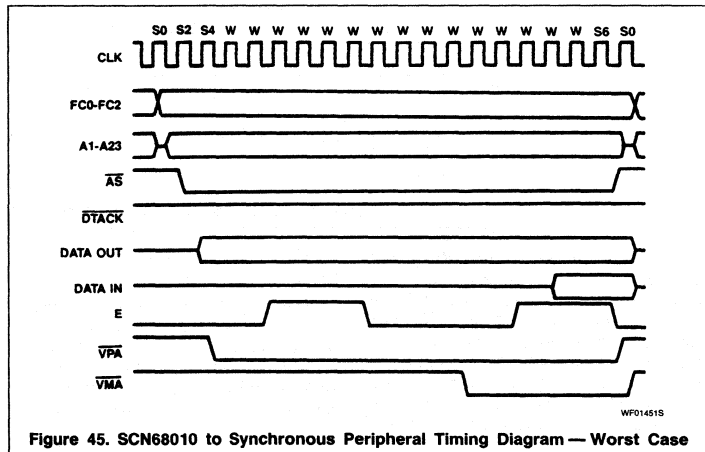

Figure 45. SCN68010 to Synchronous Peripheral Timing Diagram — Worst Case

cycles before E rises (or three clock cycles after E falls).

2. Worst Case —  $\overline{VPA}$  is recognized as being asserted on the falling edge two clock cycles before E rises (or four clock cycles after E falls).

During a read cycle, the processor latches the peripheral data in state 6. For all cycles, the processor negates the address and data strobes one-half clock cycle later in state 7 and the enable signal goes low at this time. Another half clock later, the address bus is

put in the high-impedance state. During a write cycle, the data bus is put in the high-impedance state and the read/write signal is switched high. The peripheral logic must remove  $\overline{VPA}$  within one clock after the address strobe is negated.

$\overline{DTACK}$  should not be asserted while  $\overline{VPA}$  is asserted. Notice that the SCN68010  $\overline{VMA}$  is active low, contrasted with the active high synchronous  $\overline{VMA}$ . This allows the processor to put its buses in the high-impedance state on DMA requests without inadvertently selecting the peripherals.

## 16-Bit Virtual Memory Microprocessor

SCN68010

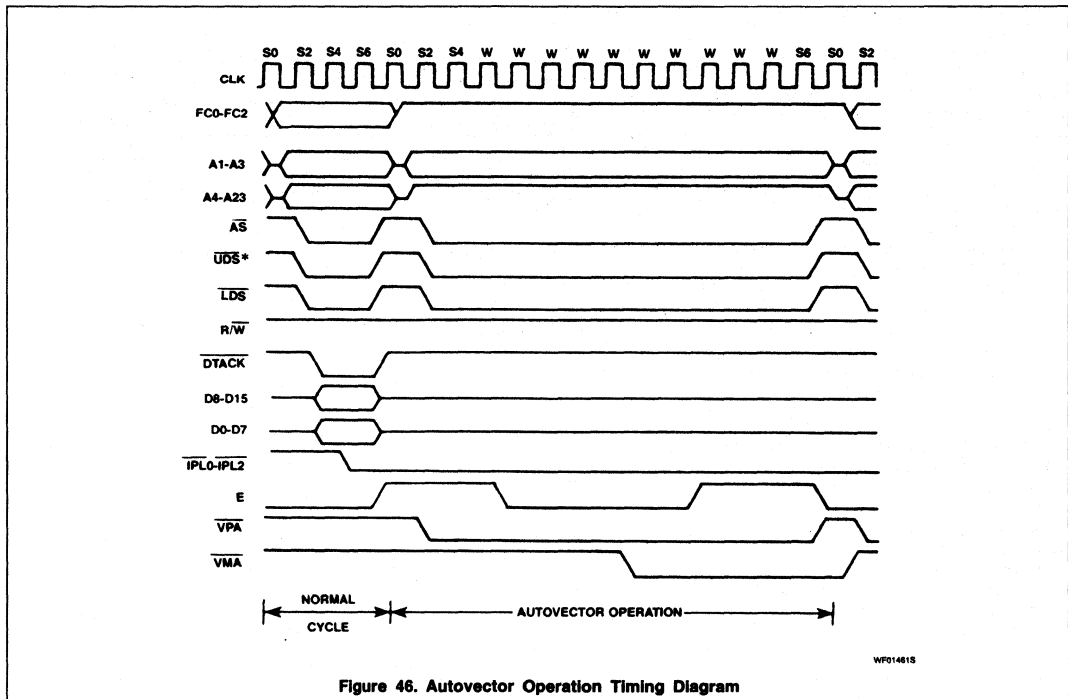

Figure 46. Autovector Operation Timing Diagram

**Interrupt Interface Operation**

During an interrupt acknowledge cycle while the processor is fetching the vector, if  $\overline{VPA}$  is asserted the SCN68010 will assert  $\overline{VMA}$  and complete a normal synchronous read cycle as shown in Figure 46. The processor will then use an internally generated vector that is a function of the interrupt being serviced. This process is known as autovectoring. The sev-

en autovectors are vector numbers 25 through 31 (decimal).

Autovectoring operates in the same fashion (but is not restricted to) the synchronous interrupt sequence. The basic difference is that there are six normal interrupt vectors and one NMI type vector. As with both the synchronous and the SCN68010's normal vec-

tored interrupt, the interrupt service routine can be located anywhere in the address space. This is due to the fact that while the vector numbers are fixed, the contents of the vector table entries are assigned by the user.

Since  $\overline{VMA}$  is asserted during autovectoring, the synchronous peripheral address decoding should prevent unintended accesses.



## 16-Bit Virtual Memory Microprocessor

SCN68010

**INSTRUCTION SET AND EXECUTION TIMES****Instruction Set**

The following paragraphs provide information about the addressing categories and instruction set of the SCN68010.

**Addressing Categories**

Effective address modes may be categorized by the ways in which they may be used. The following classifications will be used in the instruction definitions:

Data	If an effective address mode may be used to refer to data operands, it is considered a data addressing effective address mode.
Memory	If an effective address mode may be used to refer to memory operands, it is considered a memory addressing effective address mode.
Alterable	If an effective address mode may be used to refer to alterable (writeable) operands, it is considered an alterable addressing effective address mode.
Control	If an effective address mode may be used to refer to memory operands without an associated size, it is considered a control addressing effective address mode.

**Table 22. Effective Addressing Mode Categories**

EFFECTIVE ADDRESS MODES	MODE	REGISTER	DATA	ADDRESSING CATEGORIES		
				Memory	Control	Alterable
Dn	000	Register number	X	-	-	X
An	001	Register number	-	-	-	X
(An)	010	Register number	X	X	X	X
(An)+	011	Register number	X	X	-	X
-(An)	100	Register number	X	X	-	X
d(An)	101	Register number	X	X	X	X
d(An, ix)	110	Register number	X	X	X	X
xxx.W	111	000	X	X	X	X
xxx.L	111	001	X	X	X	X
d(PC)	111	010	X	X	X	-
d(PC, ix)	111	011	X	X	X	-
#xxx	111	100	X	X	-	-

These categories may be combined, so that additional, more restrictive, classifications may be defined. For example, the instruction descriptions use such classifications as alterable memory or data alterable. The former refers to those addressing modes which are both alterable and memory addresses, and

the latter refers to addressing modes which are both data and alterable. Table 22 shows the various categories to which each of the effective address modes belong. Table 23 is the instruction set summary.

## 16-Bit Virtual Memory Microprocessor

SCN68010

Table 23. Instruction Set

MNEMONIC	DESCRIPTION	OPERATION	CONDITION CODES				
			X	N	Z	V	C
ABCD	Add decimal with extend	$(\text{Destination})_{10} + (\text{Source})_{10} + X \rightarrow \text{Destination}$	*	U	*	U	*
ADD	Add binary	$(\text{Destination}) + (\text{Source}) \rightarrow \text{Destination}$	*	*	*	*	*
ADDA	Add address	$(\text{Destination}) + (\text{Source}) \rightarrow \text{Destination}$	-	-	-	-	-
ADDI	Add immediate	$(\text{Destination}) + \text{Immediate Data} \rightarrow \text{Destination}$	*	*	*	*	*
ADDQ	Add quick	$(\text{Destination}) + \text{Immediate Data} \rightarrow \text{Destination}$	*	*	*	*	*
ADDX	Add extended	$(\text{Destination}) + (\text{Source}) + X = \text{Destination}$	*	*	*	*	*
AND	AND logical	$(\text{Destination}) \wedge \text{Source} \rightarrow \text{Destination}$	-	*	*	0	0
ANDI	AND immediate	$(\text{Destination}) \wedge \text{Immediate Data} \rightarrow \text{Destination}$	-	*	*	0	0
ANDI to CCR	AND immediate to condition codes	$(\text{Source}) \wedge \text{CCR} \rightarrow \text{CCR}$	*	*	*	*	*
ANDI to SR	AND immediate to status register	$(\text{Source}) \wedge \text{SR} \rightarrow \text{SR}$	*	*	*	*	*
ASL, ASR	Arithmetic shift	$(\text{Destination})$ Shifted by $\langle \text{count} \rangle \rightarrow \text{Destination}$	*	*	*	*	*
B <sub>CC</sub>	Branch conditionally	If <sub>CC</sub> the PC + d $\rightarrow$ PC	-	-	-	-	-
BCHG	Test a bit and change	$\sim(\langle \text{bit number} \rangle) \text{ OF Destination} \rightarrow Z$ $\sim(\langle \text{bit number} \rangle) \text{ OF Destination} \rightarrow$ $\langle \text{bit number} \rangle \text{ OF Destination}$	-	-	*	-	-
BCLR	Test a bit and clear	$\sim(\langle \text{bit number} \rangle) \text{ OF Destination} \rightarrow Z$ $0 \rightarrow \langle \text{bit number} \rangle \text{ OF Destination}$	-	-	*	-	-
BRA	Branch always	$(\text{PC}) + \text{displacement} \rightarrow \text{PC}$	-	-	-	-	-
BSET	Test a bit and set	$\sim(\langle \text{bit number} \rangle) \text{ OF Destination} \rightarrow Z$ $1 \rightarrow \langle \text{bit number} \rangle \text{ OF Destination}$	-	-	*	-	-
BSR	Branch to subroutine	$(\text{PC}) \rightarrow -(\text{SP}); (\text{PC}) + d \rightarrow \text{PC}$	-	-	-	-	-
BTST	Test a bit	$\sim(\langle \text{bit number} \rangle) \text{ OF Destination} \rightarrow Z$	-	-	*	-	-
CHK	Check register against bounds	If $D_n < 0$ or $D_n > (\langle \text{ea} \rangle)$ then TRAP	-	*	U	U	U
CLR	Clear and operand	$0 \rightarrow \text{Destination}$	-	0	1	0	0
CMP	Compare	$(\text{Destination}) - (\text{Source})$	-	*	*	*	*
CMPA	Compare address	$(\text{Destination}) - (\text{Source})$	-	*	*	*	*
CMPI	Compare immediate	$(\text{Destination}) - \text{Immediate Data}$	-	*	*	*	*
CMPM	Compare memory	$(\text{Destination}) - (\text{Source})$	-	*	*	*	*
DB <sub>CC</sub>	Test condition, decrement and branch	if $\sim \text{CC}$ then $D_n - 1 \rightarrow D_n$ ; if $D_n \neq -1$ then $\text{PC} + d \rightarrow \text{PC}$	-	-	-	-	-
DIVS	Signed divide	$(\text{Destination})/(\text{Source}) \rightarrow \text{Destination}$	-	*	*	*	0
DIVU	Unsigned divide	$(\text{Destination})/(\text{Source}) \rightarrow \text{Destination}$	-	*	*	*	0
EOR	Exclusive OR logical	$(\text{Destination}) \oplus (\text{Source}) \rightarrow \text{Destination}$	-	*	*	0	0
EORI	Exclusive OR immediate	$(\text{Destination}) \oplus \text{Immediate Data} \rightarrow \text{Destination}$	-	*	*	0	0
EORI to CCR	Exclusive OR immediate to condition codes	$(\text{Source}) \oplus \text{CCR} \rightarrow \text{CCR}$	*	*	*	*	*
EORI to SR	Exclusive OR immediate to status register	$(\text{Source}) \oplus \text{SR} \rightarrow \text{SR}$	*	*	*	*	*
EXG	Exchange register	$(R_x) \leftrightarrow (R_y)$	-	-	-	-	-
EXT	Sign extend	$(\text{Destination})$ Sign-Extended $\rightarrow \text{Destination}$	-	*	*	0	0
JMP	Jump	$(\text{Destination}) \rightarrow \text{PC}$	-	-	-	-	-
JSR	Jump to subroutine	$(\text{PC}) \rightarrow -(\text{SP}); \text{Destination} \rightarrow \text{PC}$	-	-	-	-	-
LEA	Load effective address	$\text{Destination} \rightarrow A_n$	-	-	-	-	-
LINK	Link and allocate	$(A_n) \rightarrow -(\text{SP}); (\text{SP}) \rightarrow A_n; (\text{SP}) + \rightarrow \text{SP}$	-	-	-	-	-
LSL, LSR	Logical shift	$(\text{Destination})$ Shifted by $\langle \text{count} \rangle \rightarrow \text{Destination}$	*	*	*	0	*
MOVE	Move data from source to destination	$(\text{Source}) \rightarrow \text{Destination}$	-	*	*	0	0
MOVE to CCR	Move to condition code	$(\text{Source}) \rightarrow \text{CCR}$	*	*	*	*	*
MOVE from CCR	Move from condition codes	$(\text{CCR}) \rightarrow \text{Destination}$	-	-	-	-	-
MOVE to SR	Move to the status register	$(\text{Source}) \rightarrow \text{SR}$	*	*	*	*	*
MOVE from SR	Move from the status register	$(\text{SR}) \rightarrow \text{Destination}$	-	-	-	-	-
MOVE USP	Move user stack pointer	$(\text{USP}) \rightarrow A_n; (A_n) = A_r \text{ USP}$	-	-	-	-	-
MOVEA	Move address	$(\text{Source}) \rightarrow \text{Destination}$	-	-	-	-	-
MOVEC	Move control register	$(Cr) \rightarrow R_n; (R_n) \rightarrow Cr$	-	-	-	-	-

16-Bit Virtual Memory Microprocessor

SCN68010

2

Table 23. Instruction Set (Continued)

MNEMONIC	DESCRIPTION	OPERATION	CONDITION CODES				
			X	N	Z	V	C
MOVEM	Move multiple registers	(Registers) → Destination (Source) → Registers	-	-	-	-	-
MOVEP	Move peripheral data	(Source) → Destination	-	-	-	-	-
MOVEQ	Move quick	Immediate Data → Destination	-	*	*	0	0
MOVES	Move alternate address space	(Dn) → Destination; (Source) → Dn	-	-	-	-	-
MULS	Signed multiply	(Destination)X (Source) → Destination	-	*	*	0	0
MULU	Unsigned multiply	(Destination)X (Source) → Destination	-	*	*	0	0
NBCD	Negate decimal with extend	0 - (Destination) <sub>10</sub> - X → Destination	*	U	*	U	*
NEG	Negate	0 - (Destination) → Destination	*	*	*	*	*
NEGX	Negate with extend	0 - (Destination) - X → Destination	*	*	*	*	*
NOP	No operation	-	-	-	-	-	-
NOT	Logical complement	~ (Destination) → Destination	-	*	*	0	0
OR	Inclusive OR logical	(Destination) v (Source) → Destination	-	*	*	0	0
ORI	Inclusive OR immediate	(Destination) v Immediate Data → Destination	-	*	*	0	0
ORI to CCR	Inclusive OR immediate to condition codes	(Source) v CCR → CCR	*	*	*	*	*
ORI to SR	Inclusive OR immediate to status register	(Source) v SR → SR	*	*	*	*	*
PEA	Push effective address	Destination → -(SP)	-	-	-	-	-
RESET	Reset external device	-	-	-	-	-	-
ROL, ROR	Rotate (without extend)	(Destination) Rotated by < count > → Destination	-	*	*	0	*
ROXL, ROXR	Rotate with extend	(Destination) Rotated by < count > → Destination	*	*	*	0	*
RTD	Return and deallocate stack	(SP)+ → PC; (SP) + d → SP	-	-	-	-	-
RTE	Return from exception	(SP) + → SR; (SP) + → PC	*	*	*	*	*
RTR	Return and restore condition codes	(SP) + → CC; (SP) + → PC	*	*	*	*	*
RTS	Return from subroutine	(SP) + → PC	-	-	-	-	-
SBCD	Subtract decimal with extend	(Destination) <sub>10</sub> - (Source) <sub>10</sub> - X → Destination	*	U	*	U	*
S <sub>CC</sub>	Set according to condition	If <sub>CC</sub> then 1's → Destination else 0's → Destination	-	-	-	-	-
STOP	Load status register and stop	Immediate Data → SR; STOP	*	*	*	*	*
SUB	Subtract binary	(Destination) - (Source) → Destination	*	*	*	*	*
SUBA	Subtract address	(Destination) - (Source) → Destination	-	-	-	-	-
SUBI	Subtract immediate	(Destination) - Immediate Data → Destination	*	*	*	*	*
SUBQ	Subtract quick	(Destination) - Immediate Data → Destination	*	*	*	*	*
SUBX	Subtract with extend	(Destination) - (Source) - X → Destination	*	*	*	*	*
SWAP	Swap register halves	Register [31:16] ↔ Register [15:0]	-	*	*	0	0
TAS	Test and set an operand	(Destination) Tested → CC; 1 → [?] OF Destination	-	*	*	0	0
TRAP	Trap	(PC) → -(SSP); (SR) → -(SSP); (Vector) → PC	-	-	-	-	-
TRAPV	Trap on overflow	If V set then TRAP	-	-	-	-	-
TST	Test and operand	(Destination) Tested → CC	-	*	*	0	0
UNLK	Unlink	(An) → SP; (SP) + → An	-	-	-	-	-

NOTES:

- [ ] = bit number
- ⊕ logical exclusive OR
- ^ logical AND
- v logical OR
- ~ logical complement
- \* affected
- unaffected
- 0 cleared
- 1 set
- U undefined

## 16-Bit Virtual Memory Microprocessor

SCN68010

**Instruction Prefetch**

The SCN68010 uses a two-word tightly-coupled instruction prefetch mechanism to enhance performance. This mechanism is described in terms of the microcode operations involved. If the execution of an instruction is defined to begin when the microroutine for that instruction is entered, some features of the prefetch mechanism can be described.

1. When execution of an instruction begins, the operation word and the word following have already been fetched. The operation word is in the instruction decoder.
2. In the case of multi-word instructions, as each additional word of the instruction is used internally, a fetch is made to the instruction stream to replace it.
3. The last fetch for an instruction from the instruction stream is made when the operation word is discarded and decoding is started on the next instruction.
4. If the instruction is a single-word instruction causing a branch, the second word is not used. But because this word is fetched by the preceding instruction, it is impossible to avoid this superfluous fetch.
5. In the case of an interrupt or trace exception, both prefetched words are not used.
6. The program counter usually points to the last word fetched from the instruction stream.

**Loop Mode Operation**

The SCN68010 has several features that provide efficient execution of program loops. One of these features is the DBcc looping primitive instruction. The DBcc instruction operates on three operands, a loop counter, a branch condition, and a branch displacement. When the DBcc is executed in loop mode, the contents of the low order word of the register specified as the loop counter is decremented by one and compared to minus one. If equal to minus one, the result of the decrement is placed back into the count register and the next sequential instruction is executed, otherwise the condition code register is checked against the specified branch condition. If the condition is true, the result of the decrement is discarded and the next sequential instruction is executed. Finally, if the count register is not equal to minus one and the branch condition is false, the branch displacement is

LEA	SOURCE, A0	Load a pointer to source data
LEA	DEST, A1	Load a pointer to destination
MOVE. W	#LENGTH, D0	Load the counter register
LOOP	MOVE. W (A0)+, (A1)+	Loop to move the block of data
DBEQ	D0, LOOP	Stop if data word is zero

Figure 47. DBcc Loop Program Example

added to the program counter and instruction execution continues at that new address. Note that this is slightly different than non-looped execution; however, the results are the same.

An example of using the DBcc instruction in a simple loop for moving a block of data is shown in Figure 47. In this program, the block of data 'LENGTH' words long at address 'SOURCE' is to be moved to address 'DEST' provided that none of the words moved are equal to zero. When the effect of instruction prefetch on this loop is examined it can be seen that the bus activity during the loop execution would be:

1. Fetch the MOVE.W instruction,
2. Fetch the DBEQ instruction,
3. Read the operand where A0 points,
4. Write the operand where A1 points,
5. Fetch the DBEQ branch displacement, and
6. If loop conditions are met, return to step 1.

During this loop, five bus cycles are executed; however, only two bus cycles perform the data movement. Since the SCN68010 has a two word prefetch queue in addition to a one word instruction decode register, it is evident that the three instruction fetches in this loop could be eliminated by placing the MOVE.W word in the instruction decode register and holding the DBEQ instruction and its branch displacement in the prefetch queue. The SCN68010 has the ability to do this by entering the loop mode of operation. During loop mode operation, all opcode fetches are suppressed and only operand reads and writes are performed until an exit loop condition is met.

Loop mode operation is transparent to the programmer, with only two conditions re-

quired for the SCN68010 to enter the loop mode. First, a DBcc instruction must be executed with both branch conditions met and a branch displacement of minus four; which indicates that the branch is to a one word instruction preceding the DBcc instruction. Second, when the processor fetches the instruction at the branch address, it is checked to determine whether it is one of the allowed looping instructions. If it is, the loop mode is entered. Thus, the single word looped instruction and the first word of the DBcc instruction will each be fetched twice when the loop is entered; but no instruction fetches will occur again until the DBcc loop conditions fail.

In addition to the normal termination conditions for a loop, there are several conditions that will cause the SCN68010 to exit loop mode operation. These conditions are interrupts, trace exceptions, reset errors, and bus errors. Interrupts are honored after each execution of the DBcc instruction, but not after the execution of the looped instruction. If an interrupt exception occurs, loop mode operation is terminated and can be restarted on return from the interrupt handler. If the T bit is set, trace exceptions will occur at the end of both the loop instruction and the DBcc instruction and thus loop mode operation is not available. Reset will abort all processing, including the loop mode. Bus errors during the loop mode will be treated the same as in normal processing; however, when the RTE instruction is used to continue the execution of the looped instruction, the three word loop will not be re-fetched.

The loopable instructions available on the SCN68010 are listed in Table 24. These instructions may use the three address register indirect addressing modes to form one word looping instructions; (An), (An)+, and -(An).

## 16-Bit Virtual Memory Microprocessor

SCN68010

Table 24. MC68010 Loopable Instructions

OPCODES	APPLICABLE ADDRESSING MODES	OPCODES	APPLICABLE ADDRESSING MODES
MOVE [BWL]	(Ay) to (Ax) (Ay) to (Ax)+ (Ay) to -(Ax) (Ay)+ to (Ax) (Ay)+ to (Ax)+ (Ay)+ to -(Ax) -(Ay) to (Ax) -(Ay) to (Ax)+ -(Ay) to -(Ax) Ry to (Ax) Ry to (Ax)+	ABCD [B] ADDX [BWL] SBCD [B] SUBX [BWL]	-(Ay) to -(Ax)
ADD [BWL] AND [BWL] CMP [BWL] OR [BWL] SUB [BWL]	(Ay) to Dx (Ay)+ to Dx -(Ay) to Dx	CMP [BWL]	(Ay)+ to (Ax)+
ADDA [WL] CMPA [WL] SUBA [WL]	(Ay) to Ax -(Ay) to Ax (Ay)+ to Ax	CLR [BWL] NEG [BWL] NEGX [BWL] NOT [BWL] TST [BWL] NBCD [B]	(Ay) (Ay)+ -(Ay)
ADD [BWL] AND [BWL] EOR [BWL] OR [BWL] SUB [BWL]	Dx to (Ay) Dx to (Ay)+ Dx to -(Ay)	ASL [W] ASR [W] LSL [W] LSR [W] ROL [W] ROR [W] ROXL [W] ROXR [W]	(Ay) by #1 (Ay)+ by #1 -(Ay) by #1

**NOTE:**  
[B, W, or L] indicate an operand size of byte, word, or long word.

## Instruction Execution Times

The following paragraphs contain listings of the instruction execution times in terms of external clock (CLK) periods. In this timing data, it is assumed that both memory read and write cycle times are four clock periods. Any wait states caused by a longer memory cycle must be added to the total instruction time. The number of bus read and write cycles for each instruction is also included with the timing data. This data is enclosed in parenthesis following the execution periods and is shown as (r/w) where r is the number of read cycles and w is the number of write cycles.

**NOTE**

The number of clock periods includes instruction fetches and all applicable operand fetches and stores.

**Operand Effective Address Calculation Times**

Table 25 lists the number of clock periods required to compute an instruction's effective address. It includes fetching of any extension words, the address computation, and fetching of the memory operand if necessary. Several instructions do not need the operand at an effective address to be fetched and thus require fewer clock periods to calculate a given effective address than the instructions that do fetch the effective address operand. The number of bus read and write cycles is shown in parentheses as (r/w). Note there are no write cycles involved in processing the effective address.

Table 25. Effective Address Calculation Times

ADDRESSING MODE		BYTE, WORD		LONG	
		Fetch	No Fetch	Fetch	No Fetch
<b>Register</b>					
Dn	Data register direct	0(0/0)	-	0(0/0)	-
An	Address register direct	0(0/0)	-	0(0/0)	-
<b>Memory</b>					
(An)	Address register indirect	4(1/0)	2(0/0)	8(2/0)	2(0/0)
(An)+	Address register indirect with postincrement	4(1/0)	4(0/0)	8(2/0)	4(0/0)
-(An)	Address register indirect with predecrement	6(1/0)	4(0/0)	10(2/0)	4(0/0)
d(An)	Address register indirect with displacement	8(2/0)	4(0/0)	12(3/0)	4(1/0)
d(An, ix)*	Address register indirect with index	10(2/0)	8(1/0)	14(3/0)	8(1/0)
xxx.W	Absolute short	8(2/0)	4(1/0)	12(3/0)	4(1/0)
xxx.L	Absolute long	12(3/0)	8(2/0)	16(4/0)	8(2/0)
d(PC)	Program counter with displacement	8(2/0)	-	12(3/0)	-
d(PC, ix)	Program counter with index	10(2/0)	-	14(3/0)	-
#xxx	Immediate	4(1/0)	-	8(2/0)	-

**NOTE:**

\*The size of the index register (ix) does not affect execution time.

## 16-Bit Virtual Memory Microprocessor

SCN68010

Table 26. Move Byte and Word Instruction Execution Times

SOURCE	DESTINATION								
	Dn	An	(An)	(An)+	-(An)	d(An)	d(An, ix)*	xxx.W	xxx.L
Dn	4(1/0)	4(1/0)	8(1/1)	8(1/1)	8(1/1)	12(2/1)	14(2/1)	12(2/1)	16(3/1)
An	4(1/0)	4(1/0)	8(1/1)	8(1/1)	8(1/1)	12(2/1)	14(2/1)	12(2/1)	16(3/1)
(An)	8(2/0)	8(2/0)	12(2/1)	12(2/1)	12(2/1)	16(3/1)	18(3/1)	16(3/1)	20(4/1)
(An)+	8(2/0)	8(2/0)	12(2/1)	12(2/1)	12(2/1)	16(3/1)	18(3/1)	16(3/1)	20(4/1)
-(An)	10(2/0)	10(2/0)	14(2/1)	14(2/1)	14(2/1)	18(3/1)	20(3/1)	18(3/1)	22(4/1)
d(An)	12(3/0)	12(3/0)	16(3/1)	16(3/1)	16(3/1)	20(4/1)	22(4/1)	20(4/1)	24(5/1)
d(An, ix)*	14(3/0)	14(3/0)	18(3/1)	18(3/1)	18(3/1)	22(4/1)	24(4/1)	22(4/1)	26(5/1)
xxx.W	12(3/0)	12(3/0)	16(3/1)	16(3/1)	16(3/1)	20(4/1)	22(4/1)	20(4/1)	24(5/1)
xxx.L	16(4/0)	16(4/0)	20(4/1)	20(4/1)	20(4/1)	24(5/1)	26(5/1)	24(5/1)	28(6/1)
d(PC)	12(3/0)	12(3/0)	16(3/1)	16(3/1)	16(3/1)	20(4/1)	22(4/1)	20(4/1)	24(5/1)
d(PC, ix)*	14(3/0)	14(3/0)	18(3/1)	18(3/1)	18(3/1)	22(4/1)	24(4/1)	22(4/1)	26(5/1)
#xxx	8(2/0)	8(2/0)	12(2/1)	12(2/1)	12(2/1)	16(3/1)	18(3/1)	16(3/1)	20(4/1)

## NOTE:

\*The size of the index register (ix) does not affect execution time.

## Move Instruction Execution Times

Tables 26, 27, 28, and 29 indicate the number of clock periods for the move instruction. This data includes instruction fetch, operand reads, and operand writes. The number of bus read and write cycles is shown in parenthesis as (r/w).

Table 27. Move Byte and Word Instruction Loop Mode Execution Times

SOURCE	LOOP CONTINUED			LOOP TERMINATED					
	Valid Count, cc False			Valid Count, cc True			Expired Count		
	Destination								
	(An)	(An)+	-(An)	(An)	(An)+	-(An)	(An)	(An)+	-(An)
Dn	10(0/1)	10(0/1)	-	18(2/1)	18(2/1)	-	16(2/1)	16(2/1)	-
An*	10(0/1)	10(0/1)	-	18(2/1)	18(2/1)	-	16(2/1)	16(2/1)	-
(An)	14(1/1)	14(1/1)	16(1/1)	20(3/1)	20(3/1)	22(3/1)	18(3/1)	18(3/1)	20(3/1)
(An)+	14(1/1)	14(1/1)	16(1/1)	20(3/1)	20(3/1)	22(3/1)	18(3/1)	18(3/1)	20(3/1)
-(An)	16(1/1)	16(1/1)	18(1/1)	22(3/1)	22(3/1)	24(3/1)	20(3/1)	20(3/1)	22(3/1)

## NOTE:

\*Word only.

Table 28. Move Long Instruction Execution Times

SOURCE	DESTINATION								
	Dn	An	(An)	(An)+	-(An)	d(An)	d(An, ix)*	xxx.W	xxx.L
Dn	4(1/0)	4(1/0)	12(1/2)	12(1/2)	14(1/2)	16(2/2)	18(2/2)	16(2/2)	20(3/2)
An	4(1/0)	4(1/0)	12(1/2)	12(1/2)	14(1/2)	16(2/2)	18(2/2)	16(2/2)	20(3/2)
(An)	12(3/0)	12(3/0)	20(3/2)	20(3/2)	24(3/2)	24(4/2)	26(4/2)	24(4/2)	28(5/2)
(An)+	12(3/0)	12(3/0)	20(3/2)	20(3/2)	20(3/2)	24(4/2)	26(4/2)	24(4/2)	28(5/2)
-(An)	14(3/0)	14(3/0)	22(3/2)	22(3/2)	22(3/2)	26(4/2)	28(4/2)	26(4/2)	30(5/2)
d(An)	16(4/0)	16(4/0)	24(4/2)	24(4/2)	24(4/2)	28(5/2)	30(5/2)	28(5/2)	32(6/2)
d(An, ix)*	18(4/0)	18(4/0)	26(4/2)	26(4/2)	26(4/2)	30(5/2)	32(5/2)	30(5/2)	34(6/2)
xxx.W	16(4/0)	16(4/0)	24(4/2)	24(4/2)	24(4/2)	28(5/2)	30(5/2)	28(5/2)	32(6/2)
xxx.L	20(5/0)	20(5/0)	28(5/2)	28(5/2)	28(5/2)	32(6/2)	34(6/2)	32(6/2)	36(7/2)
d(PC)	16(4/0)	16(4/0)	24(4/2)	24(4/2)	24(4/2)	28(5/2)	30(5/2)	28(5/2)	32(5/2)
d(PC, ix)*	18(4/0)	18(4/0)	26(4/2)	26(4/2)	26(4/2)	30(5/2)	32(5/2)	30(5/2)	34(6/2)
#xxx	12(3/0)	12(3/0)	20(3/2)	20(3/2)	20(3/2)	24(4/2)	26(4/2)	24(4/2)	28(5/2)

## NOTE:

\*The size of the index register (ix) does not affect execution time.

## 16-Bit Virtual Memory Microprocessor

SCN68010

Table 29. Move Long Instruction Loop Mode Execution Times

SOURCE	LOOP CONTINUED			LOOP TERMINATED					
	Valid Count, cc False			Valid Count, cc True			Expired Count		
	Destination								
	(An)	(An)+	-(An)	(An)	(An)+	-(An)	(An)	(An)+	-(An)
Dn	14(0/2)	14(0/2)	-	20(2/2)	20(2/2)	-	18(2/2)	18(2/2)	-
An	14(0/2)	14(0/2)	-	20(2/2)	20(2/2)	-	18(2/2)	18(2/2)	-
(An)	22(2/2)	22(2/2)	24(2/2)	28(4/2)	28(4/2)	30(4/2)	24(4/2)	24(4/2)	26(4/2)
(An)+	22(2/2)	22(2/2)	24(2/2)	28(4/2)	28(4/2)	30(4/2)	24(4/2)	24(4/2)	26(4/2)
-(An)	24(2/2)	24(2/2)	26(2/2)	30(4/2)	30(4/2)	32(4/2)	26(4/2)	26(4/2)	28(4/2)

## Standard Instruction Execution Times

The number of clock periods shown in Tables 30 and 31 indicate the time required to perform the operations, store the results, and read the next instruction. The number of bus read and write cycles is shown in parenthesis as (r/w). The number of clock periods and the number of read and write cycles must be added respectively to those of the effective address calculation where indicated.

In Tables 30 and 31 the headings have the following meanings: An = address register operand, Dn = data register operand, ea = an operand specified by an effective address, and M = memory effective address operand.

Table 30. Standard Instruction Execution Times

INSTRUCTION	SIZE	op <ea>, An***	op <ea>, Dn	op Dn, <M>
ADD	byte, word	8(1/0)+	4(1/0)+	8(1/1)+
	long	6(1/0)+	6(1/0)	12(1/2)+
AND	byte, word	-	4(1/0)+	8(1/1)+
	long	-	6(1/0)+	12(1/2)+
CMP	byte, word	6(1/0)+	4(1/0)+	-
	long	6(1/0)+	6(1/0)+	-
DIVS	-	-	122(1/0)+	-
DIVU	-	-	108(1/0)+	-
EOR	byte, word	-	4(1/0)+**	18(1/1)+
	long	-	6(1/0)**	12(1/2)+
MULS	-	-	42(1/0)+*	-
MULU	-	-	40(1/0)+	-
OR	byte, word	-	4(1/0)+	8(1/1)+
	long	-	6(1/0)+	12(1/2)+
SUB	byte, word	8(1/0)+	4(1/0)+	8(1/1)+
	long	6(1/0)+	6(1/0)+	12(1/2)+

## NOTES:

+ Add effective address calculation time

\*Indicates maximum value

\*\*Only available addressing mode is data register direct

\*\*\*Word or long only

## 16-Bit Virtual Memory Microprocessor

SCN68010

Table 31. Standard Instruction Loop Mode Execution Times

INSTRUC- TION	SIZE	LOOP CONTINUED			LOOP TERMINATED					
		Valid Count, cc False			Valid Count, cc True			Expired Count		
		op <ea>, An*	op <ea>, Dn	op Dn, <ea>	op <ea>, An*	op <ea>, Dn	op Dn, <ea>	op <ea>, An*	op <ea>, Dn	op Dn, <ea>
ADD	byte, word	18(1/0)	16(1/0)	16(1/1)	24(3/0)	22(3/0)	22(3/1)	22(3/0)	20(3/0)	20(3/1)
	long	22(2/0)	22(2/0)	24(2/2)	28(4/0)	28(4/0)	30(4/2)	26(4/0)	26(4/0)	28(4/2)
AND	byte, word	-	16(1/0)	16(1/1)	-	22(3/0)	22(3/1)	-	20(3/0)	20(3/1)
	long	-	22(2/0)	24(2/2)	-	28(4/0)	30(4/2)	-	26(4/0)	28(4/2)
CMP	byte, word	12(1/0)	12(1/0)	-	18(3/0)	18(3/0)	-	16(3/0)	16(4/0)	-
	long	18(2/0)	18(2/0)	-	24(4/0)	24(4/0)	-	20(4/0)	20(4/0)	-
EOR	byte, word	-	-	16(1/0)	-	-	22(3/1)	-	-	20(3/1)
	long	-	-	24(2/2)	-	-	30(4/2)	-	-	28(4/2)
OR	byte, word	-	16(1/0)	16(1/0)	-	22(3/0)	22(3/1)	-	20(3/0)	20(3/1)
	long	-	22(2/0)	24(2/2)	-	28(4/0)	30(4/2)	-	26(4/0)	28(4/2)
SUB	byte, word	18(1/0)	16(1/0)	16(1/1)	24(3/0)	22(3/0)	22(3/1)	22(3/0)	20(3/0)	20(3/1)
	long	22(2/0)	20(2/0)	24(2/2)	28(4/0)	26(4/0)	30(4/2)	26(4/0)	24(4/0)	28(4/2)

## NOTES:

\*Word or long only.

&lt;ea&gt; may be (An), +(An), or -(An) only. Add two clock periods to the table value if &lt;ea&gt; is -(An).

## Immediate Instruction Execution Times

The number of clock periods shown in Table 32 includes the time to fetch immediate operands, perform the operations, store the results, and read the next operation. The number of bus read and write cycles is shown in parenthesis as (r/w). The number of clock periods and the number of read and write cycles must be added respectively to those of the effective address calculation where indicated.

In Table 32, the headings have the following meanings: # = immediate operand, Dn = data register operand, AN = address register operand, and M = memory operand.

Table 32. Immediate Instruction Execution Times

INSTRUC- TION	SIZE	op #, Dn	op #, An	op #, M
ADDI	byte, word	8(2/0)	-	12(2/1)+
	long	14(3/0)	-	20(3/2)+
ADDQ	byte, word	4(1/0)	4(1/0)*	8(1/1)+
	long	8(1/0)	8(1/0)	12(1/2)+
ANDI	byte, word	8(2/0)	-	12(2/1)+
	long	14(3/0)	-	20(3/1)+
CMPI	byte, word	8(2/0)	-	8(2/0)+
	long	12(3/0)	-	12(3/0)+
EORI	byte, word	8(2/0)	-	12(2/1)+
	long	14(3/0)	-	20(3/2)+
MOVEQ	long	4(1/0)	-	-
ORI	byte, word	8(2/0)	-	12(2/1)+
	long	14(3/0)	-	20(3/2)+
SUBI	byte, word	8(2/0)	-	12(2/1)+
	long	14(3/0)	-	20(3/2)+
SUBQ	byte, word	4(1/0)	4(1/0)*	8(1/1)+
	long	8(1/0)	8(1/0)	12(1/2)+

## NOTES:

+ Add effective address calculation time

\*Word only



16-Bit Virtual Memory Microprocessor

SCN68010

2

**Single Operand Instruction Execution Times**

Tables 33, 34, and 35 indicate the number of clock periods for the single operand instructions. The number of bus read and write cycles is shown in parenthesis as (r/w). The number of clock periods and the number of read and write cycles must be added respectively to those of the effective address calculation where indicated.

**Table 33. Single Operand Instruction Execution Times**

INSTRUCTION	SIZE	REGISTER	MEMORY
NBCD	byte	6(1/0)	8(1/1)+
NEG	byte, word	4(1/0)	8(1/1)+
	long	6(1/0)	12(1/2)+
NEGX	byte, word	4(1/0)	8(1/1)+
	long	6(1/0)	12(1/2)+
NOT	byte, word	4(1/0)	8(1/1)+
	long	6(1/0)	12(1/2)+
S <sub>cc</sub>	byte, false	4(1/0)	8(1/1)+ *
	byte, true	4(1/0)	8(1/1)+ *
TAS	byte	4(1/0)	14(2/1)+ *
TST	byte, word	4(1/0)	4(1/0)
	long	4(1/0)	4(1/0)+

**NOTES:**  
 + Add effective address calculation time  
 \*Use non-fetching effective address calculation time.

**Table 34. Clear Instruction Execution Times**

	SIZE	Dn	An	(An)	(An)+	-(An)	d(An)	(An, ix)*	xxx.W	xxx.L
CLR	byte, word	4(1/0)	-	8(1/1)	8(1/1)	10(1/1)	12(2/1)	16(2/1)	12(2/1)	16(3/1)
	long	6(1/0)	-	12(1/2)	12(1/2)	14(1/2)	16(2/2)	20(2/2)	16(2/2)	20(3/2)

**NOTE:**  
 \*The size of the index register (ix) does not affect execution time.

**Table 35. Single Operand Instruction Loop Mode Execution Times**

INSTRUCTION	SIZE	LOOP CONTINUED			LOOP TERMINATED					
		Valid Count, cc False			Valid Count, cc True			Expired Count		
		(An)	(An)+	-(An)	(An)	(An)+	-(An)	(An)	(An)+	-(An)
CLR	byte, word	10(0/1)	10(0/1)	12(0/1)	18(2/1)	18(2/1)	20(2/0)	16(2/1)	16(2/1)	18(2/1)
	long	14(0/2)	14(0/2)	16(0/2)	22(2/2)	22(2/2)	24(2/2)	20(2/2)	20(2/2)	22(2/2)
NBCD	byte	18(1/1)	18(1/1)	20(1/1)	24(3/1)	24(3/1)	26(3/1)	22(3/1)	22(3/1)	24(3/1)
NEG	byte, word	16(1/1)	16(1/1)	18(2/2)	22(3/1)	22(3/1)	24(3/1)	20(3/1)	20(3/1)	22(3/1)
	long	24(2/2)	24(2/2)	26(2/2)	30(4/2)	30(4/2)	32(4/2)	28(4/2)	28(4/2)	30(4/2)
NEGX	byte, word	16(1/1)	16(1/1)	18(2/2)	22(3/1)	22(3/1)	24(3/1)	20(3/1)	20(3/1)	22(3/1)
	long	24(2/2)	24(2/2)	26(2/2)	30(4/2)	30(4/2)	32(4/2)	28(4/2)	28(4/2)	30(4/2)
NOT	byte, word	16(1/1)	16(1/1)	18(2/2)	22(3/1)	22(3/1)	24(3/1)	20(3/1)	20(3/1)	22(3/1)
	long	24(2/2)	24(2/2)	26(2/2)	30(4/2)	30(4/2)	32(4/2)	28(4/2)	28(4/2)	30(4/2)
TST	byte, word	12(1/0)	12(1/0)	14(1/0)	18(3/0)	18(3/0)	20(3/0)	16(3/0)	16(3/0)	18(3/0)
	long	18(2/0)	18(2/0)	20(2/0)	24(4/0)	24(4/0)	26(4/0)	20(4/0)	20(4/0)	22(4/0)

## 16-Bit Virtual Memory Microprocessor

SCN68010

**Shift/Rotate Instruction Execution Times**

Tables 36 and 37 indicate the number of clock periods for the shift and rotate instructions. The number of bus read and write cycles is shown in parenthesis as (r/w). The number of clock periods and the number of read and write cycles must be added respectively to those of the effective address calculation where indicated.

**Table 36. Shift/Rotate Instruction Execution Times**

INSTRUCTION	SIZE	REGISTER	MEMORY*
ASR, ASL	byte, word	6 + 2n(1/0)	8(1/1)+
	long	8 + 2n(1/0)	-
LSR, LSL	byte, word	6 + 2n(1/0)	8(1/1)+
	long	8 + 2n(1/0)	-
ROR, ROL	byte, word	6 + 2n(1/0)	8(1/1)+
	long	8 + 2n(1/0)	-
ROXR, ROXL	byte, word	6 + 2n(1/0)	8(1/1)+
	long	8 + 2n(1/0)	-

**NOTES:**

+ Add effective address calculation time

n is the shift or rotate count

\*Word only

**Table 37. Shift/Rotate Instruction Loop Mode Execution Times**

INSTRUCTION	SIZE	LOOP CONTINUED			LOOP TERMINATED					
		Valid Count, cc False			Valid Count, cc True			Expired Count		
		(An)	(An)+	-(An)	(An)	(An)+	-(An)	(An)	(An)+	-(An)
ASR, ASL	word	18(1/1)	18(1/1)	20(1/1)	24(3/1)	24(3/1)	26(3/1)	22(3/1)	22(3/1)	24(3/1)
LSR, LSL	word	18(1/1)	18(1/1)	20(1/1)	24(3/1)	24(3/1)	26(3/1)	22(3/1)	22(3/1)	24(3/1)
ROR, ROL	word	18(1/1)	18(1/1)	20(1/1)	24(3/1)	24(3/1)	26(3/1)	22(3/1)	22(3/1)	24(3/1)
ROXR, ROXL	word	18(1/1)	18(1/1)	20(1/1)	24(3/1)	24(3/1)	26(3/1)	22(3/1)	22(3/1)	24(3/1)

**Bit Manipulation Instruction Execution Times**

Table 38 indicates the number of clock periods required for the bit manipulation instructions. The number of bus read and write cycles is shown in parenthesis as (r/w). The number of clock periods and the number of read and write cycles must be added respectively to those of the effective address calculation where indicated.

**Table 38. Bit Manipulation Instruction Execution Times**

INSTRUCTION	SIZE	DYNAMIC		STATIC	
		Register	Memory	Register	Memory
BCHG	byte	-	8(1/1)+	-	12(2/1)+
	long	8(1/0)*	-	12(2/0)*	-
BCLR	byte	-	10(1/1)+	-	14(2/1)+
	long	10(1/0)*	-	14(2/0)*	-
BSET	byte	-	8(1/0)+	-	12(2/1)+
	long	8(1/0)*	-	12(2/0)*	-
BTST	byte	-	4(1/0)+	-	8(2/0)+
	long	6(1/0)*	-	10(2/0)	-

**NOTES:**

+ Add effective address calculation time

\*Indicates maximum value

# 16-Bit Virtual Memory Microprocessor

SCN68010

2

### Conditional Instruction Execution Times

Table 39 indicates the number of clock periods required for the conditional instructions. The number of bus read and write cycles is indicated in parenthesis as (r/w). The number of clock periods and the number of read and write cycles must be added respectively to those of the effective address calculation where indicated.

### JMP, JSR, LEA, PEA, and MOVEM Instruction Execution Times

Table 40 indicates the number of clock periods required for the jump, jump-to-subroutine, load effective address, push effective address, and move multiple registers instructions. The number of bus read and write cycles is shown in parenthesis as (r/w).

**Table 39. Conditional Instruction Execution Times**

INSTRUCTION	DISPLACEMENT	BRANCH TAKEN	BRANCH NOT TAKEN
BCC	byte	10(2/0)	6(1/0)
	word	10(2/0)	10(2/0)
BRA	byte	10(2/0)	-
	word	10(2/0)	-
BSR	byte	18(2/2)	-
	word	18(2/2)	-
DBCC	cc true	-	10(2/0)
	cc false	10(2/0)	16(3/0)

**Table 40. JMP, JSR, LEA, PEA, and Movem Instruction Execution Times**

INSTRUCTION	SIZE	(An)	(An)+	-(An)	d(An)	d(An, ix)+	xxx.W	xxx.L	d(PC)	d(PC, ix)*
JMP	-	8(2/0)	-	-	10(2/0)	14(3/0)	10(2/0)	12(3/0)	10(2/0)	14(3/0)
JSR	-	16(2/2)	-	-	18(2/2)	22(2/2)	18(2/2)	20(3/2)	18(2/2)	22(2/2)
LEA	-	4(1/0)	-	-	8(2/0)	12(2/0)	8(2/0)	12(3/0)	8(2/0)	12(2/0)
PEA	-	12(1/2)	-	-	16(2/2)	20(2/2)	16(2/2)	20(3/2)	16(2/2)	20(2/2)
MOVEM M → R	word	12 + 4n (3 + n/0)	12 + 4n (3 + n/0)	-	16 + 4n (4 + n/0)	18 + 4n (4 + n/0)	16 + 4n (4 + n/0)	20 + 4n (5 + n/0)	16 + 4n (4 + n/0)	18 + 4n (4 + n/0)
	long	12 + 8n (3 + 2n/0)	12 + 8n (3 + 2n/0)	-	16 + 8n (4 + 2n/0)	18 + 8n (4 + 2n/0)	16 + 8n (4 + 2n/0)	20 + 8n (5 + 2n/0)	16 + 8n (4 + 2n/0)	18 + 8n (4 + 2n/0)
MOVEM R → M	word	8 + 4n (2/n)	-	8 + 4n (2/n)	12 + 4n (3/n)	14 + 4n (3/n)	12 + 4n (3/n)	16 + 4n (4/n)	-	-
	long	8 + 8n (2/2n)	-	8 + 8n (2/2n)	12 + 8n (3/2n)	14 + 8n (3/2n)	12 + 8n (3/2n)	16 + 8n (4/2n)	-	-

**NOTES:**

n is the number of registers to move

\*The size of the index register (ix) does not affect the instruction's execution time

### Multi-Precision Instruction Execution Times

Table 41 indicates the number of clock periods for the multi-precision instructions. The number of clock periods includes the time to fetch both operands, perform the operations, store the results, and read the next instructions. The number of read and write cycles is shown in parenthesis as (r/w).

In Table 41, the headings have the following meanings: Dn = data register operand and M = memory operand.

**Table 41. Multi-Precision Instruction Execution Times**

INSTRUCTION	SIZE	NON-LOOPED	LOOP MODE			
			Continued	Terminated		
				Valid Count, cc False	Valid Count, cc True	Expired Count
		op Dn, Dn	op M, M*			
ADDX	byte, word	4(1/0)	18(3/10)	22(2/1)	28(4/1)	26(4/1)
	long	6(1/0)	30(5/2)	32(4/2)	38(6/2)	36(6/2)
CMPM	byte, word	-	12(3/0)	14(2/0)	20(4/0)	18(4/0)
	long	-	20(5/0)	24(4/0)	30(6/0)	26(6/0)
SUBX	byte, word	4(1/0)	18(3/1)	22(2/1)	28(4/1)	26(4/1)
	long	6(1/0)	30(5/2)	32(4/2)	38(6/2)	36(6/2)
ABCD	byte	6(1/0)	18(3/1)	24(2/1)	30(4/1)	28(4/1)
SBCD	byte	6(1/0)	18(3/1)	24(2/1)	30(4/1)	28(4/1)

**NOTE:**

\*Source and destination ea is (An)+ for CMPM and -(An) for all others.

## 16-Bit Virtual Memory Microprocessor

SCN68010

**Miscellaneous Instruction Execution Times**

Table 42 indicates the number of clock periods for the following miscellaneous instructions. The number of bus read and write cycle is shown in parenthesis as (r/w). The number of clock periods plus the number of read and write cycles must be added to those of the effective address calculation where indicated.

**Exception Processing Execution Times**

Table 43 indicates the number of clock periods for exception processing. The number of clock periods includes the time for all stacking, the vector fetch, and the fetch of the first two instruction words of the handler routine. The number of bus read and write cycles is shown in parenthesis as (r/w).

**Table 43. Exception Processing Execution Times**

EXCEPTION	
Address error	126(4/26)
Breakpoint instruction*	42(5/4)
Bus error	126(4/26)
CHK instruction**	44(5/4)+
Divide by zero	42(5/4)
Illegal instruction	38(4/4)
Interrupt*	46(5/4)
MOVEC, illegal cr**	46(5/4)
Privilege violation	38(4/4)
Reset***	40(6/0)
RTE, illegal format	50(7/4)
RTE, illegal revision	70(12/4)
Trace	38(4/4)
TRAP instruction	38(4/4)
TRAPV instruction	40(5/4)

**NOTES:**

- + Add effective address calculation time.
- \*The interrupt acknowledge and breakpoint cycles are assumed to take four clock periods.
- \*\*Indicates maximum value
- \*\*\*Indicates the time from when RESET and HALT are first sampled as negated to when instruction execution starts.

**Table 42. Miscellaneous Instruction Execution Times**

INSTRUCTION	SIZE	REGISTER	MEMORY	REGISTER → DESTINATION**	SOURCE** → REGISTER
ANDI to CCR	-	16(2/0)	-	-	-
ANDI to SR	-	16(2/0)	-	-	-
CHK	-	8(1/0)+	-	-	-
EORI to CCR	-	16(2/0)	-	-	-
EORI to SR	-	16(2/0)	-	-	-
EXG	-	6(1/0)	-	-	-
EXT	word	4(1/0)	-	-	-
	long	4(1/0)	-	-	-
LINK	-	16(2/2)	-	-	-
MOVE from CCR	-	4(1/0)	8(1/1)+*	-	-
MOVE to CCR	-	12(2/0)	12(2/0)+	-	-
MOVE from SR	-	4(1/0)	8(1/1)+*	-	-
MOVE to SR	-	12(2/0)	12(2/0)+	-	-
MOVE from USP	-	6(1/0)	-	-	-
MOVE to USP	-	6(1/0)	-	-	-
MOVEC	-	-	-	10(2/0)	12(2/0)
MOVEP	word	-	-	16(2/2)	16(4/0)
	long	-	-	24(2/4)	24(6/0)
MOVES	byte, word	-	-	16(2/1) + *	16(3/0) + *
	long	-	-	20(2/2) + *	20(4/0) + *
NOP	-	4(1/0)	-	-	-
ORI to CCR	-	16(2/0)	-	-	-
ORI to SR	-	16(2/0)	-	-	-
RESET	-	130(1/0)	-	-	-
RTD	-	16(4/0)	-	-	-
	short	24(6/0)	-	-	-
	long, retry read	112(27/10)	-	-	-
	long, retry write	112(26/1)	-	-	-
RTE	long, no retry	110(26/0)	-	-	-
	-	-	-	-	-
RTR	-	20(5/0)	-	-	-
RTS	-	16(4/0)	-	-	-
STOP	-	4(0/0)	-	-	-
SWAP	-	4(1/0)	-	-	-
TRAPV	-	4(1/0)	-	-	-
UNLK	-	12(3/0)	-	-	-

**NOTES:**

- + Add effective address calculation time.
- \* Use non-fetching effective address calculation time.
- \*\* Source or destination is a memory location for the MOVEP and MOVES instruction and a control register for the MOVEC instruction.

## 16-Bit Virtual Memory Microprocessor

SCN68010

## ABSOLUTE MAXIMUM RATINGS

SYMBOL	RATING	VALUE	UNIT
V <sub>CC</sub>	Supply voltage range	-0.3 to +7.0	V
V <sub>in</sub>	Input voltage range	-0.3 to +7.0	V
T <sub>A</sub>	Operating temperature range SCN68010 SCN68010 ceramic	T <sub>L</sub> to T <sub>H</sub> 0 to 70 -40 to 85	°C
T <sub>stg</sub>	Storage temperature range	-55 to 150	°C

## NOTE:

This device contains circuitry to protect the inputs against damage due to high static voltages or electric fields; however, it is advised that normal precautions be taken to avoid application of any voltage higher than maximum-rated voltages to this high-impedance circuit. Reliability of operation is enhanced if unused inputs are tied to an appropriate logic voltage level (e.g., either V<sub>SS</sub> or V<sub>CC</sub>).

## THERMAL CHARACTERISTICS

CHARACTERISTIC	SYMBOL	VALUE	SYMBOL	VALUE	RATING
Thermal Resistance (Still Air)	θ <sub>JA</sub>		θ <sub>JC</sub>		°C/W
Ceramic DIP		30		15*	
Pin grid array		33		15	
Plastic DIP		30		15*	
PLCC		45*		25*	

## NOTE:

\*Estimated

Table 44. Maximum Power Dissipation by Package Type Modes

PACKAGE TYPE	TEMPERATURE (°C)	MAXIMUM POWER DISSIPATION (WATTS) PER FREQUENCY (MHz)		
		8 MHz	10 MHz	12.5 MHz
Ceramic DIP	0 to 70	1.50	1.50	1.75
	-40 to 85	1.65	1.65	-
Plastic DIP	0 to 70	1.50	1.50	-
	-40 to 85	1.65	1.65	-
PGA	0 to 70	1.50	1.50	1.75
	-40 to 85	1.65	1.65	-
PLCC	0 to 70	1.50	1.50	-

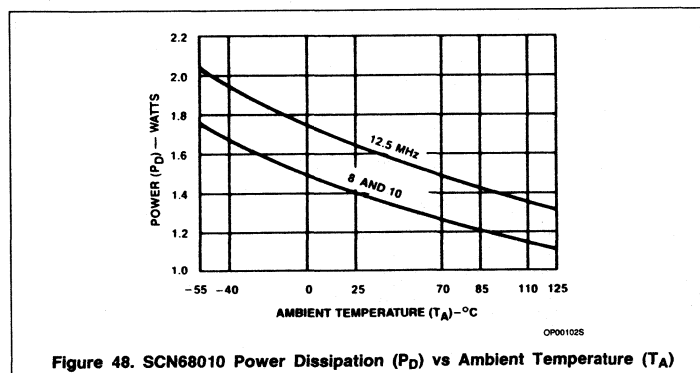
Figure 48. SCN68010 Power Dissipation (P<sub>D</sub>) vs Ambient Temperature (T<sub>A</sub>)

## Power Considerations

The average chip-junction temperature, T<sub>J</sub>, in °C can be obtained from:

$$T_J = T_A + (P_D \bullet \theta_{JA}) \quad (1)$$

Where:

T<sub>A</sub> = ambient temperature, °C

θ<sub>JA</sub> = package thermal resistance, junction-to-ambient, °C/W

P<sub>D</sub> = P<sub>INT</sub> + P<sub>I/O</sub>

P<sub>INT</sub> = I<sub>CC</sub> × V<sub>CC</sub>, watts — chip internal power

P<sub>I/O</sub> = power dissipation on input and output pins — user determined

For most applications P<sub>I/O</sub> < P<sub>INT</sub> and can be neglected.

An approximate relationship between P<sub>D</sub> and T<sub>J</sub> (if P<sub>I/O</sub> is neglected) is:

$$P_D = K \div (T_J + 273^\circ\text{C}) \quad (2)$$

Solving equations 1 and 2 for K gives:

$$K = T_D \bullet (T_A + 273^\circ\text{C}) + \theta_{JA} \bullet P_D^2 \quad (3)$$

Where K is a constant pertaining to the particular part. K can be determined from equation 3 by measuring P<sub>D</sub> (at equilibrium) for a known T<sub>A</sub>. Using this value of K the values of P<sub>D</sub> and T<sub>J</sub> can be obtained by solving equations (1) and (2) iteratively for any value of T<sub>A</sub>.

The curve shown in Figure 48 gives the graphic solution to these equations for the specification power dissipation of 1.50 and 1.75 watts over the ambient temperature range of -55°C to 125°C using a θ<sub>JA</sub> of 45°C/W for the ceramic package.

The total thermal resistance of a package (θ<sub>JA</sub>) can be separated into two components, θ<sub>JC</sub> and θ<sub>CA</sub>, representing the barrier to heat flow from the semiconductor junction to the package (case) surface (θ<sub>JC</sub>) and from the case to the outside ambient (θ<sub>CA</sub>). These terms are related by the equation:

$$\theta_{JA} = \theta_{JC} + \theta_{CA} \quad (4)$$

θ<sub>JC</sub> is device related and cannot be influenced by the user. However, θ<sub>CA</sub> is user dependent and can be minimized by such thermal management techniques as heat sinks, ambient air cooling and thermal convection. Thus, good thermal management on the part of the user can significantly reduce θ<sub>CA</sub> so that θ<sub>JA</sub> approximately equals θ<sub>JC</sub>. Substitution of θ<sub>JC</sub> for θ<sub>JA</sub> in equation (1) will result in a lower semiconductor junction temperature.

Values for thermal resistance presented in this data sheet, unless estimated, are provided for design purposes only. Thermal measurements are complex and dependent on procedure and setup. User derived values for thermal resistance may differ.

# 16-Bit Virtual Memory Microprocessor

# SCN68010

## DC ELECTRICAL CHARACTERISTICS $V_{CC} = 5V_{DC} \pm 5\%$ ; $GND = 0V_{DC}$ ; $T_A = T_L$ to $T_H$ (see Figures 49, 50, and 51)

SYMBOL	CHARACTERISTIC	MIN	MAX	UNIT
$V_{IH}$	Input high voltage	2	$V_{CC}$	V
$V_{IL}$	Input low voltage	$GND - 0.3$	0.8	V
$I_{IN}$	Input leakage current @ 5.25V BERR, BGACK, BR, DTACK, CLK, IPL0 - IPL2, VPA HALT, RESET	-	2.5 20	$\mu A$
$I_{TSI}$	3-State (off state) input current @ 2.4V/0.4V $\overline{AS}$ , A1 - A23, D0 - D15, FC0 - FC2, LDS, R/W, UDS, VMA	-	20	$\mu A$
$V_{OH}$	Output high voltage ( $I_{OH} = -400\mu A$ ) E* E**, $\overline{AS}$ , A1 - A23, $\overline{BG}$ , D0 - D15, FC0 - FC2, LDS, R/W, UDS, VMA	$V_{CC} - 0.75$ 2.4	- -	V
$V_{OL}$	Output low voltage ( $I_{OL} = 1.6mA$ ) ( $I_{OL} = 3.2mA$ ) ( $I_{OL} = 5.0mA$ ) ( $I_{OL} = 5.3mA$ ) HALT A1 - A23, $\overline{BG}$ , FC0 - FC2 RESET E, $\overline{AS}$ , D0 - D7, LDS, R/W, UDS, VMA	- - - -	0.5 0.5 0.5 -	V V V V
	Power dissipation (see Power Considerations)***	$P_D$	-	-
$C_{in}$	Capacitance ( $V_{IN} = 0V$ , $T_A = 25^\circ C$ , frequency = 1MHz)****	-	20	pF

**NOTES:**

- \* With external pullup resistor of 1.1 k $\Omega$ .
- \*\* Without external pullup resistor.
- \*\*\* During normal operation instantaneous  $V_{CC}$  current requirements may be as high as 1.5A.
- \*\*\*\* Capacitance is periodically sampled rather than 100% tested.

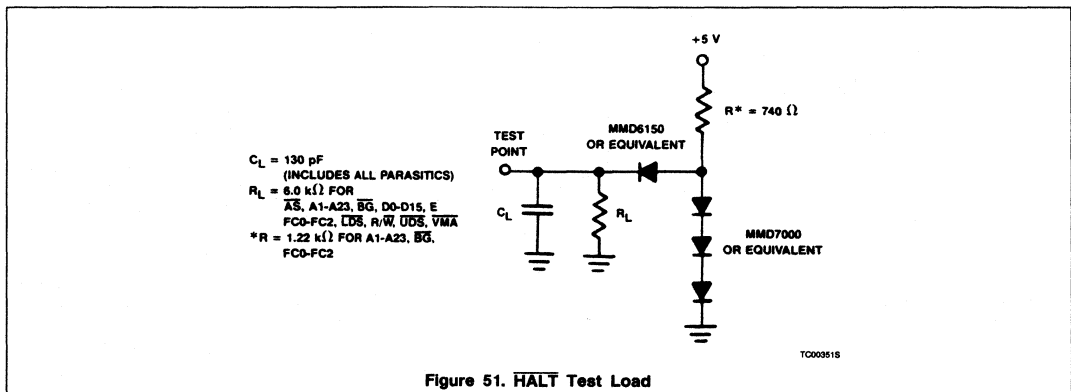
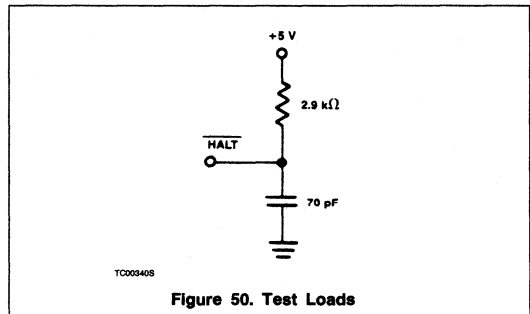
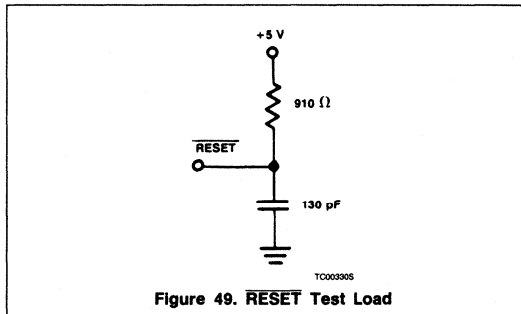

$C_L = 130$  pF  
(INCLUDES ALL PARASITICS)  
 $R_L = 6.0$  k $\Omega$  FOR  
 $\overline{AS}$ , A1-A23,  $\overline{BG}$ , D0-D15, E  
FC0-FC2, LDS, R/W, UDS, VMA  
\*R = 1.22 k $\Omega$  FOR A1-A23,  $\overline{BG}$ ,  
FC0-FC2

## 16-Bit Virtual Memory Microprocessor

SCN68010

**AC ELECTRICAL CHARACTERISTICS — Clock Input** (See Figure 52)

CHARACTERISTIC	SYMBOL	8MHz		10MHz		12.5MHz		UNIT
		Min	Max	Min	Max	Min	Max	
Frequency of operation	$f$	4	8	4	10	4	12.5	MHz
Cycle time	$t_{cyc}$	125	250	100	250	80	250	ns
Clock pulse width	$t_{CL}$	55	125	45	125	35	125	ns
	$t_{CH}$	55	125	45	125	35	125	
Rise and fall times	$t_{Cr}$	—	10	—	10	—	5	ns
	$t_{Cf}$	—	10	—	10	—	5	

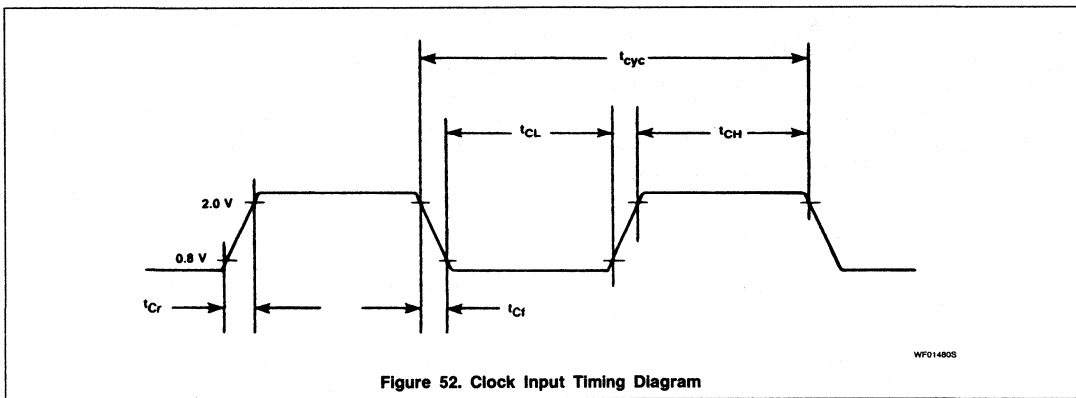

## 16-Bit Virtual Memory Microprocessor

SCN68010

**AC ELECTRICAL CHARACTERISTICS—Read and Write Cycles** ( $V_{CC} = 5V_{DC} \pm 5\%$ ;  $GND = 0V_{DC}$ ;  $T_A = T_L$  to  $T_H$  see Figures 53 and 54)

NO.	CHARACTERISTIC	8MHz		10MHz		12.5MHz		UNIT
		Min	Max	Min	Max	Min	Max	
1	Clock period	125	500	100	250	80	250	ns
2	Clock width low	55	125	45	125	35	125	ns
3	Clock width high	55	125	45	125	35	125	ns
4	Clock fall time	–	10	–	10	–	5	ns
5	Clock rise time	–	10	–	10	–	5	ns
6	Clock low to address valid	–	70	–	55	–	55	ns
6A	Clock high to FC valid	–	70	–	55	–	55	ns
7	Clock high to address, data bus high impedance (maximum)	–	80	–	70	–	60	ns
8	Clock high to address, FC invalid (minimum)	0	–	0	–	0	–	ns
9 <sup>1</sup>	Clock high to $\overline{AS}$ , $\overline{DS}$ low	0	60	0	55	0	55	ns
11 <sup>2</sup>	Address valid to $\overline{AS}$ , $\overline{DS}$ low (read)/ $\overline{AS}$ low (write)	30	–	20	–	0	–	ns
11A <sup>2</sup>	FC valid to $\overline{AS}$ , $\overline{DS}$ low (read)/ $\overline{AS}$ low (write)	60	–	50	–	40	–	ns
12 <sup>1</sup>	Clock low to $\overline{AS}$ , $\overline{DS}$ high	–	70	–	55	–	50	ns
13 <sup>2</sup>	$\overline{AS}$ , $\overline{DS}$ high to address/FC invalid	30	–	20	–	10	–	ns
14 <sup>2</sup>	$\overline{AS}$ , $\overline{DS}$ width low (read)/ $\overline{AS}$ low (write)	240	–	195	–	160	–	ns
14A <sup>2</sup>	$\overline{DS}$ width low (write)	–	115	95	–	80	–	ns
15 <sup>2</sup>	$\overline{AS}$ , $\overline{DS}$ width high	150	–	105	–	65	–	ns
16	Clock high to control bus high impedance	–	80	–	70	–	60	ns
17 <sup>2</sup>	$\overline{AS}$ , $\overline{DS}$ high to R/ $\overline{W}$ high (read)	40	–	20	–	10	–	ns
18 <sup>1</sup>	Clock high to R/ $\overline{W}$ high	0	70	0	60	0	60	ns
20 <sup>1</sup>	Clock high to R/ $\overline{W}$ low	–	70	–	60	–	60	ns
20A <sup>2</sup>	$\overline{AS}$ low to R/ $\overline{W}$ valid (write)	–	20	–	20	–	20	ns
21 <sup>2</sup>	Address valid to R/ $\overline{W}$ low (write)	20	–	0	–	0	–	ns
21A <sup>2</sup>	FC valid to R/ $\overline{W}$ low (write)	60	–	50	–	30	–	ns
22 <sup>2</sup>	R/ $\overline{W}$ low to $\overline{DS}$ low (write)	80	–	50	–	30	–	ns
23	Clock low to data out valid (write)	–	70	–	55	–	55	ns
25 <sup>2</sup>	$\overline{AS}$ , $\overline{DS}$ high to data out invalid (write)	30	–	20	–	15	–	ns
26 <sup>2</sup>	Data out valid to $\overline{DS}$ low (write)	30	–	20	–	15	–	ns
27 <sup>5</sup>	Data in to clock low (setup time on read)	15	–	10	–	10	–	ns
27A	Late $\overline{BERR}$ low to clock low (setup time)	45	–	45	–	45	–	ns
28 <sup>2</sup>	$\overline{AS}$ , $\overline{DS}$ high to $\overline{DTACK}$ high	0	245	0	190	0	150	ns
29	$\overline{AS}$ , $\overline{DS}$ high to data invalid (hold time on read)	0	–	0	–	0	–	ns
30	$\overline{AS}$ , $\overline{DS}$ high to $\overline{BERR}$ high	0	–	0	–	0	–	ns
31 <sup>2,5</sup>	$\overline{DTACK}$ low to data valid (setup time)	–	90	–	65	–	50	ns
32	$\overline{HALT}$ and $\overline{RESET}$ input transition time	0	200	0	200	0	200	ns
33	Clock high to $\overline{BG}$ low	–	70	–	60	–	50	ns
34	Clock high to $\overline{BG}$ high	–	70	–	60	–	50	ns
35	$\overline{BR}$ low to $\overline{BG}$ low	1.5	90ns +3.5	1.5	80ns +3.5	1.5	70ns +3.5	clk. per.



## 16-Bit Virtual Memory Microprocessor

SCN68010

## AC ELECTRICAL CHARACTERISTICS (Continued)

NO.	CHARACTERISTIC	8MHz		10MHz		12.5MHz		UNIT
		Min	Max	Min	Max	Min	Max	
36 <sup>6</sup>	$\overline{BR}$ high to $\overline{BG}$ high	1.5	90ns +3.5	1.5	80ns +3.5	1.5	70ns +3.5	clk. per.
37	$\overline{BGACK}$ low to $\overline{BG}$ high	1.5	90ns +3.5	1.5	80ns +3.5	1.5	70ns +3.5	clk. per.
37A <sup>7</sup>	$\overline{BGACK}$ low to $\overline{BR}$ high	20	1.5 clocks	20	1.5 clocks	20	1.5 clocks	ns
38	$\overline{BG}$ low to control, address, data bus high impedance ( $\overline{AS}$ high)	-	80	-	70	-	60	ns
39	$\overline{BG}$ width high	1.5	-	1.5	-	1.5	-	clk. per.
40	Clock low to $\overline{VM\overline{A}}$ low	-	70	-	70	-	70	ns
41	Clock low to E transition	-	70	-	55	-	45	ns
42	E output rise and fall time	-	25	-	25	-	25	ns
43	$\overline{VM\overline{A}}$ low to E high	200	-	150	-	90	-	ns
44	$\overline{AS}$ , $\overline{DS}$ high to $\overline{VP\overline{A}}$ high	0	120	0	90	0	70	ns
45	E low to control address bus invalid (address hold time)	30	-	10	-	10	-	ns
46	$\overline{BGACK}$ width	1.5	-	1.5	-	1.5	-	clk. per.
47 <sup>5</sup>	Asynchronous input setup time	20	-	20	-	20	-	ns
48 <sup>2,3</sup>	$\overline{DTACK}$ low to $\overline{BERR}$ low	-	80	-	55	-	35	ns
49 <sup>8</sup>	$\overline{AS}$ , $\overline{DS}$ high to E low	-70	70	-55	55	-45	45	ns
50	E width high	450	-	350	-	280	-	ns
51	E width low	700	-	550	-	440	-	ns
53	Clock high to data out valid	0	-	0	-	0	-	ns
54	E low to data out valid	30	-	20	-	15	-	ns
55	R/ $\overline{W}$ to data bus driven	30	-	20	-	10	-	ns
56 <sup>4</sup>	$\overline{HALT/RESET}$ pulse width	10	-	10	-	10	-	clk. per.
57	$\overline{BGACK}$ high to control bus driven	1.5	-	1.5	-	1.5	-	clk. per.
58 <sup>6</sup>	$\overline{BG}$ high to control bus driven	1.5	-	1.5	-	1.5	-	clk. per.

## NOTES:

- For a loading capacitance of less than or equal to 50pF, subtract 5ns from the values given in these columns.
- Actual value depends on clock period.
- In the absence of  $\overline{DTACK}$ ,  $\overline{BERR}$  is an asynchronous input using the asynchronous input setup time (#47).
- For power-up, the MPU must be held in  $\overline{RESET}$  state for 100ms to allow stabilization of on-chip circuitry. After the system is powered up, #56 refers to the minimum pulse width required to reset the system.
- If the asynchronous setup time (#47) requirements are satisfied, the  $\overline{DTACK}$ -low to data setup time (#31) and  $\overline{DTACK}$ -low to  $\overline{BERR}$ -low setup time (#48) requirements can be ignored. The data must only satisfy the data-in to clock-low setup time (#27) for the following clock cycle,  $\overline{BERR}$  must only satisfy the late- $\overline{BERR}$ -low to clock-low setup time (#27A) for the following clock cycle.
- The processor will negate  $\overline{BG}$  and begin driving the bus again if external arbitration logic negates  $\overline{BR}$  before asserting  $\overline{BGACK}$ .
- The minimum value must be met to guarantee proper operation. If the maximum value is exceeded,  $\overline{BG}$  may be reasserted.
- The falling edge of S6 triggers both the negation of the strobes ( $\overline{AS}$  and  $\overline{DS}$ ) and the falling edge of E. Either of these events can occur first, depending on the loading on each signal. Specification #49 indicates the absolute maximum skew that will occur between the rising edge of the strobes and the falling edge of the E clock.

# 16-Bit Virtual Memory Microprocessor

## SCN68010

These waveforms should only be referenced in regard to the edge-to-edge measurement of the timing specifications. They are not intended as a functional description of the input and output signals. Refer to other functional descriptions and their related diagrams for device operation.

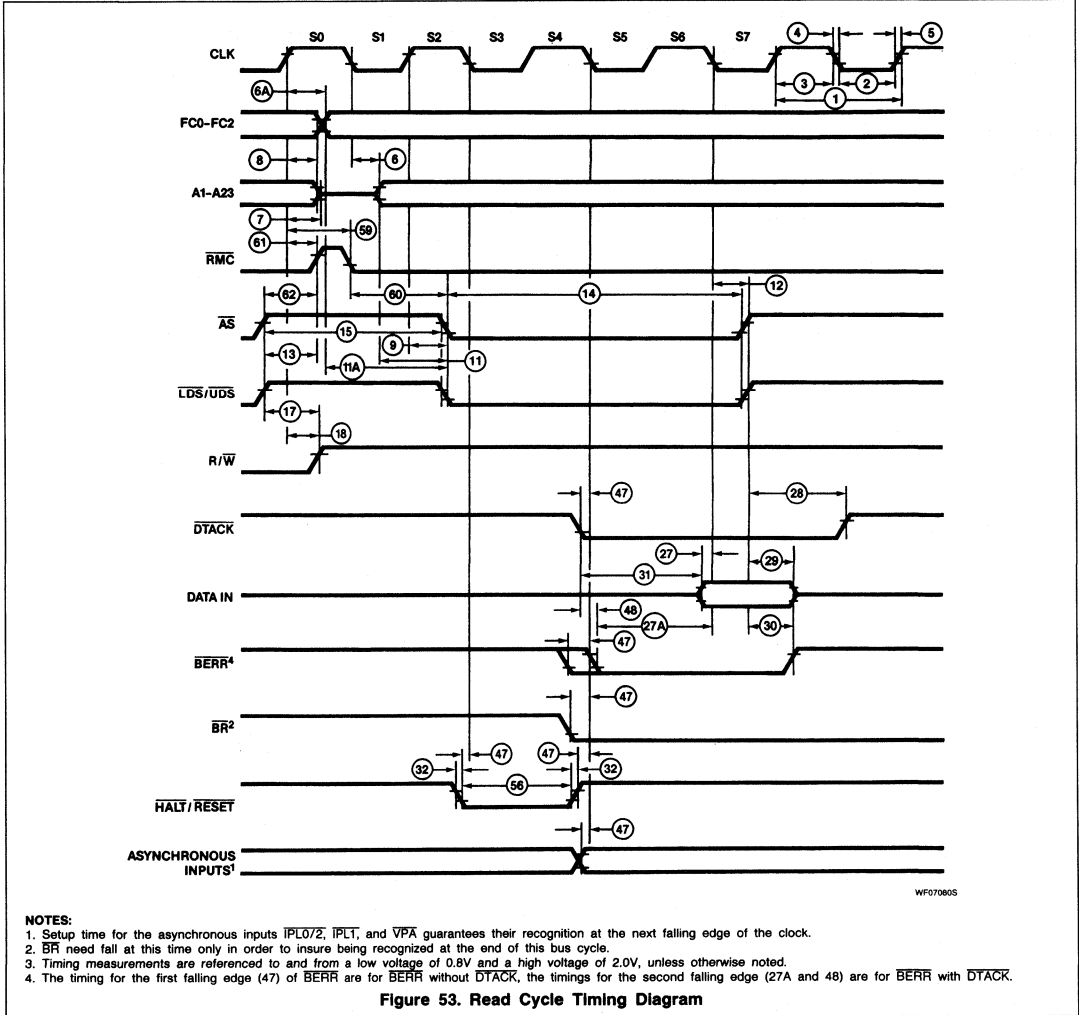

# 16-Bit Virtual Memory Microprocessor

## SCN68010

These waveforms should only be referenced in regard to the edge-to-edge measurement of the timing specifications. They are not intended as a functional description of the input and output signals. Refer to other functional descriptions and their related diagrams for device operation.

**2**

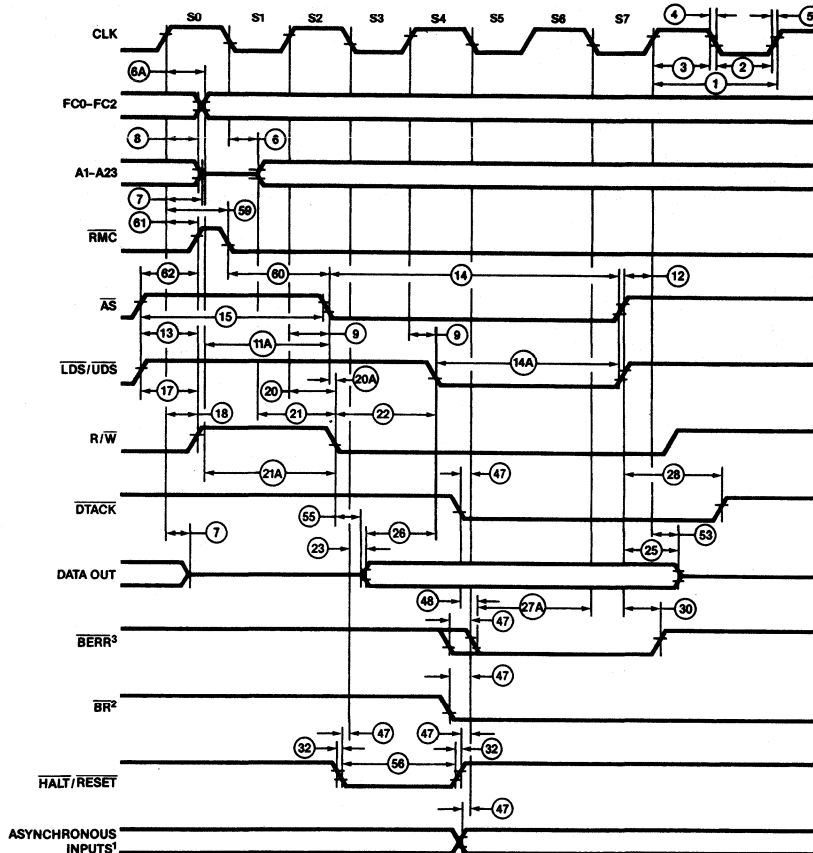

WF070805

**NOTES:**

1. Timing measurements are referenced to and from a low voltage of 0.8V and a high voltage of 2.0V, unless otherwise noted.
2. Because of loading variations, R/W may be valid after AS even though both are initiated by the rising edge of S2 (specification 20A).
3. The timing for the first falling edge (47) of BERR are for BERR without DTACK; the timings for the second falling edge (27A and 48) are for BERR with DTACK.

**Figure 54. Write Cycle Timing Diagram**

## 16-Bit Virtual Memory Microprocessor

SCN68010

**AC ELECTRICAL CHARACTERISTICS — SCN68010 to Synchronous Peripheral Cycles**  $V_{CC} = 5V_{DC} \pm 5\%$ ,  $GND = 0V_{DC}$ ,  
 $T_A = T_L$  to  $T_H$  (refer to Figures 55 and 56)

NO.	CHARACTERISTIC	8MHz		10MHz		12.5MHz		UNIT
		Min	Max	Min	Max	Min	Max	
12 <sup>1</sup>	Clock low to $\overline{AS}$ , $\overline{DS}$ high	–	70	–	55	–	50	ns
17 <sup>2</sup>	$\overline{AS}$ , $\overline{DS}$ high to R/ $\overline{W}$ high (read)	40	–	20	–	10	–	ns
20 <sup>1</sup>	Clock high to R/ $\overline{W}$ low	–	70	–	60	–	60	ns
23	Clock low to data out valid (write)	–	70	–	55	–	55	ns
27	Data in to clock low (setup time on read)	15	–	10	–	10	–	ns
40	Clock low to $\overline{VMA}$ low	–	70	–	70	–	70	ns
41	Clock low to E transition	–	70	–	55	–	45	ns
42	E output rise and fall time	–	25	–	25	–	25	ns
43	$\overline{VMA}$ low to E high	200	–	150	–	90	–	ns
44	$\overline{AS}$ , $\overline{DS}$ high to $\overline{VPA}$ high	0	120	0	90	0	70	ns
45	E low to control address bus (address hold time)	30	–	10	–	10	–	ns
47	Asynchronous input setup time	20	–	20	–	20	–	ns
49 <sup>3</sup>	$\overline{AS}$ , $\overline{DS}$ high to E low	–70	70	–55	55	–45	45	ns
50	E width high	450	–	350	–	280	–	ns
51	E width low	700	–	550	–	440	–	ns
54	E low to data out invalid	30	–	20	–	15	–	ns

**NOTES:**

- For a loading capacitance of less than or equal to 50pF, subtract 5ns from the values given in these columns.
- Actual value depends on clock period.
- The falling edge of S6 triggers both the negation of the strobes ( $\overline{AS}$  and  $\overline{DS}$ ) and the falling edge of E. Either of these events can occur first, depending on the loading on each signal. Specification #49 indicates the absolute maximum skew that will occur between the rising edge of the strobes and the falling edge of the E clock.

# 16-Bit Virtual Memory Microprocessor

SCN68010

These waveforms should only be referenced in regard to the edge-to-edge measurement of the timing specifications. They are not intended as a functional description of the input and output signals. Refer to other functional descriptions and their related diagrams for device operation.

2

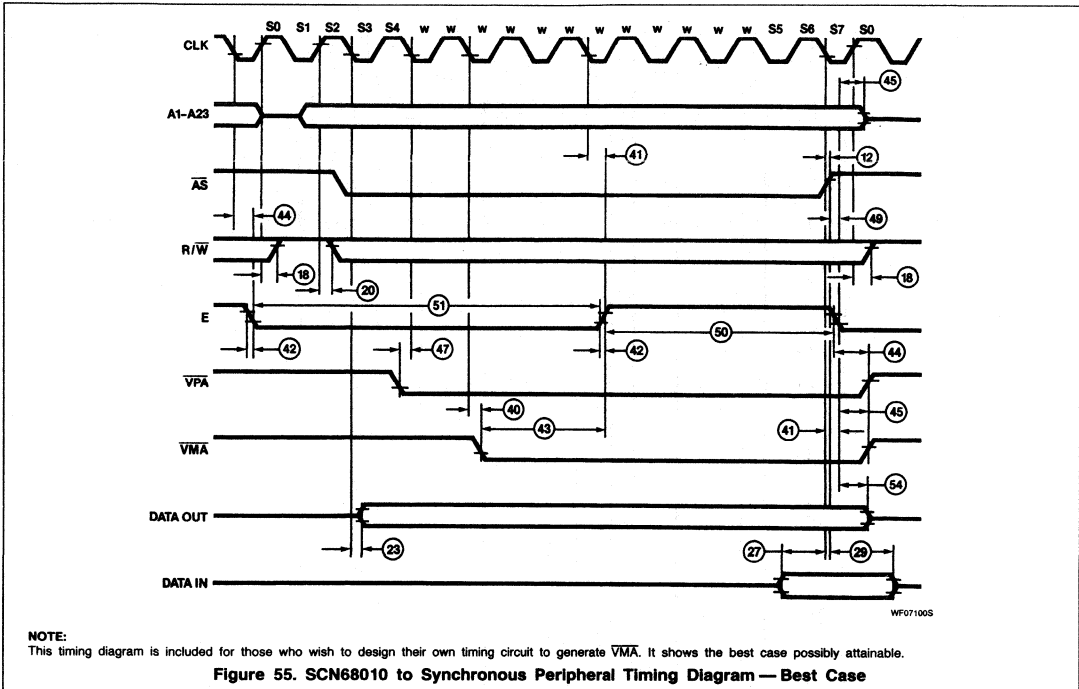

16-Bit Virtual Memory Microprocessor

SCN68010

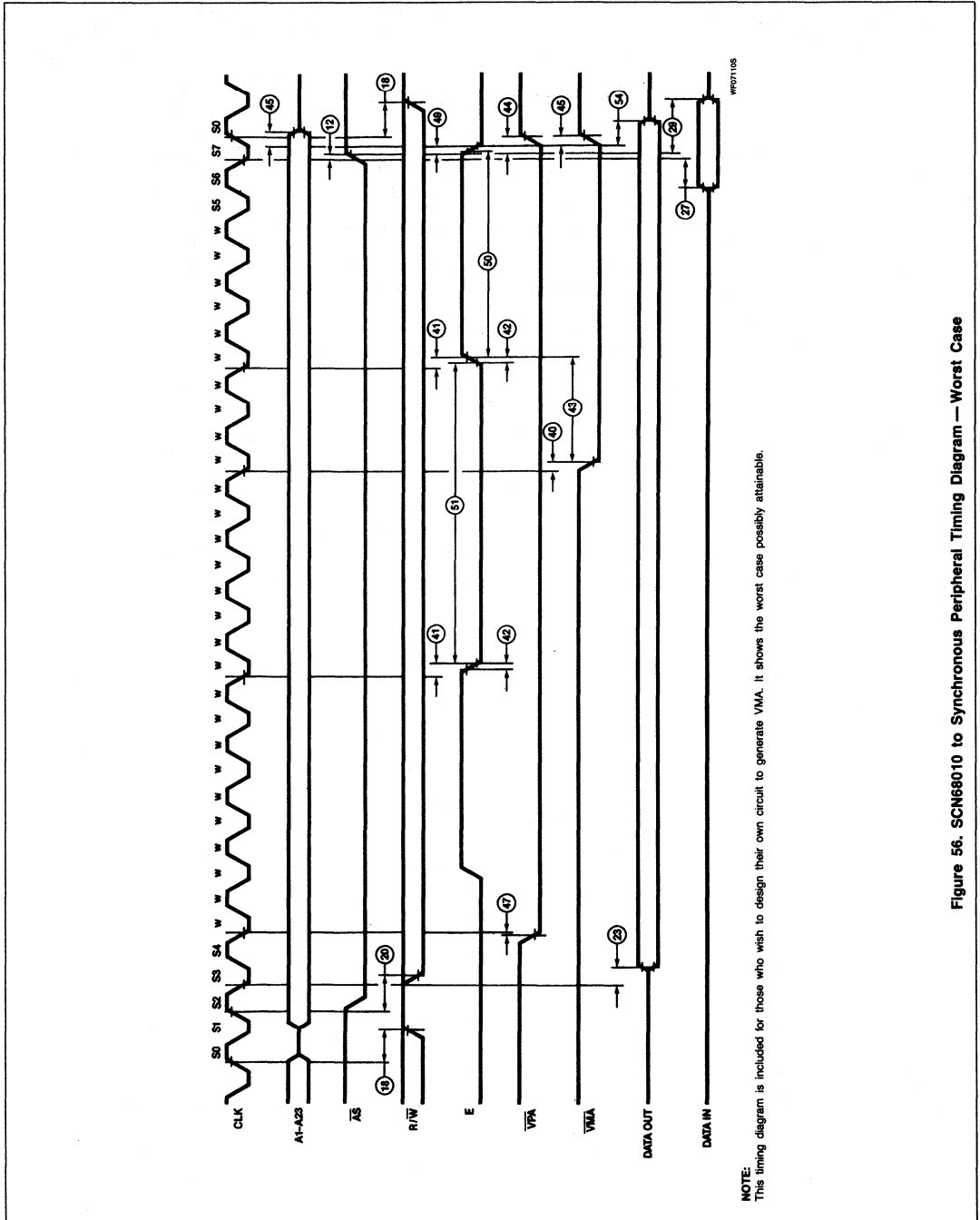

Figure 56. SCN68010 to Synchronous Peripheral Timing Diagram — Worst Case

## 16-Bit Virtual Memory Microprocessor

SCN68010

**AC ELECTRICAL CHARACTERISTICS — Bus Arbitration**  $V_{CC}=5V_{DC} \pm 5\%$ ;  $GND = 0V_{DC}$ ;  $T_A = T_L$  to  $T_H$  (see Figures 57, 58, 59)

NO.	CHARACTERISTIC	8MHz		10MHz		12.5MHz		UNIT
		Min	Max	Min	Max	Min	Max	
7	Clock high to address, data bus high impedance (maximum)	-	80	-	70	-	60	ns
16	Clock high to control bus high impedance	-	80	-	70	-	60	ns
33	Clock high to $\overline{BG}$ low	-	70	-	60	-	50	ns
34	Clock high to $\overline{BG}$ high	-	70	-	60	-	50	ns
35	$\overline{BR}$ low to $\overline{BG}$ low	1.5	90ns +3.5	1.5	80ns +3.5	1.5	70ns +3.5	clk. per.
36 <sup>2</sup>	$\overline{BR}$ high to $\overline{BG}$ high	1.5	90ns +3.5	1.5	80ns +3.5	1.5	70ns +3.5	clk. per.
37	$\overline{BGACK}$ low to $\overline{BG}$ high	1.5	90ns 3.5	1.5	80ns 3.5	1.5	70ns 3.5	clk. per.
37A <sup>3</sup>	$\overline{BGACK}$ low to $\overline{BR}$ high	20	1.5 Clocks	20	1.5 Clocks	20	1.5 Clocks	ns
38	$\overline{BG}$ low to control, address, data bus high impedance ( $\overline{AS}$ high)	-	80	-	70	-	60	ns
39	$\overline{BG}$ width high	1.5	-	1.5	-	1.5	-	clk. per
46	$\overline{BGACK}$ width	1.5	-	1.5	-	1.5	-	clk. per.
47	Asynchronous input setup time	20	-	20	-	20	-	ns
57 <sup>2</sup>	$\overline{BGACK}$ high to control bus driven	1.5	-	1.5	-	1.5	-	clk. per.
58 <sup>1,2</sup>	$\overline{BG}$ high to control bus driven	1.5	-	1.5	-	1.5	-	clk. per.

**NOTES:**

1. The nanosecond value shown in the specification is the asynchronous input setup time (spec. #47).
2. The processor will negate  $\overline{BG}$  and begin driving the bus again if external arbitration logic negates  $\overline{BR}$  before asserting  $\overline{BGACK}$ .
3. The minimum value must be met to guarantee proper operation. If the maximum value is exceeded,  $\overline{BG}$  may be reasserted.

# 16-Bit Virtual Memory Microprocessor

## SCN68010

These waveforms should only be referenced in regard to the edge-to-edge measurement of the timing specifications. They are not intended as a functional description of the input and output signals. Refer to other functional descriptions and their related diagrams for device operation.

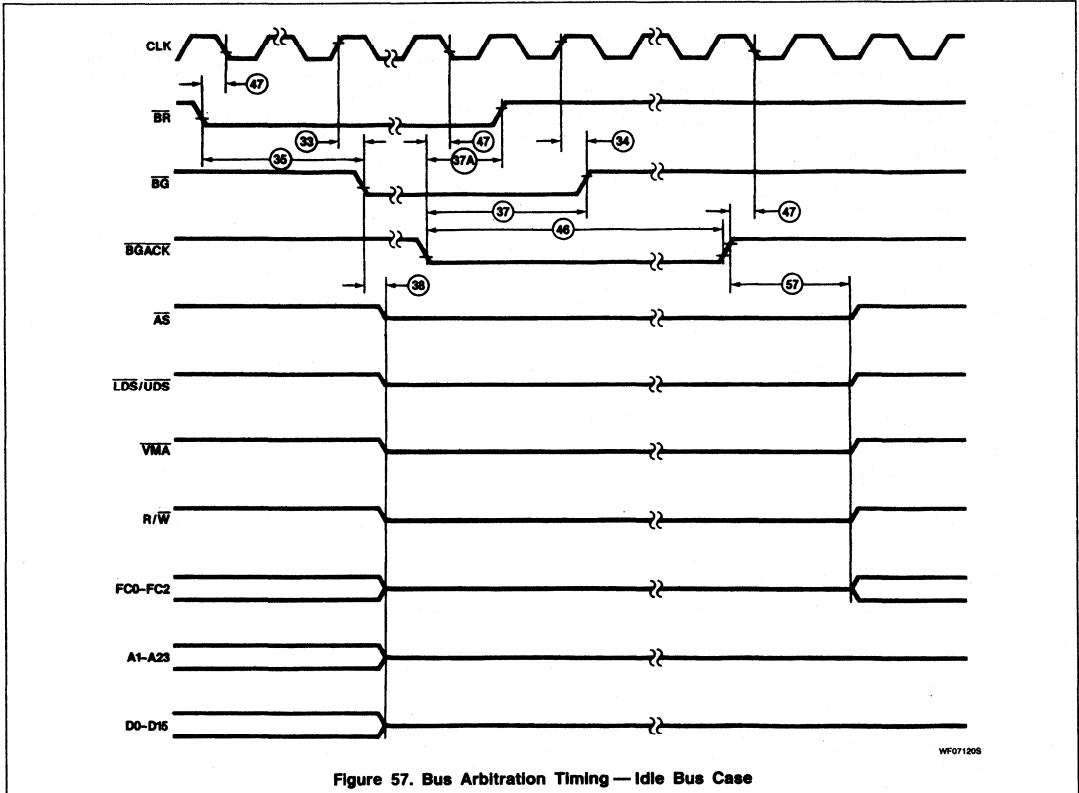

Figure 57. Bus Arbitration Timing — Idle Bus Case

WF071208



16-Bit Virtual Memory Microprocessor

SCN68010

These waveforms should only be referenced in regard to the edge-to-edge measurement of the timing specifications. They are not intended as a functional description of the input and output signals. Refer to other functional descriptions and their related diagrams for device operation.

**2**

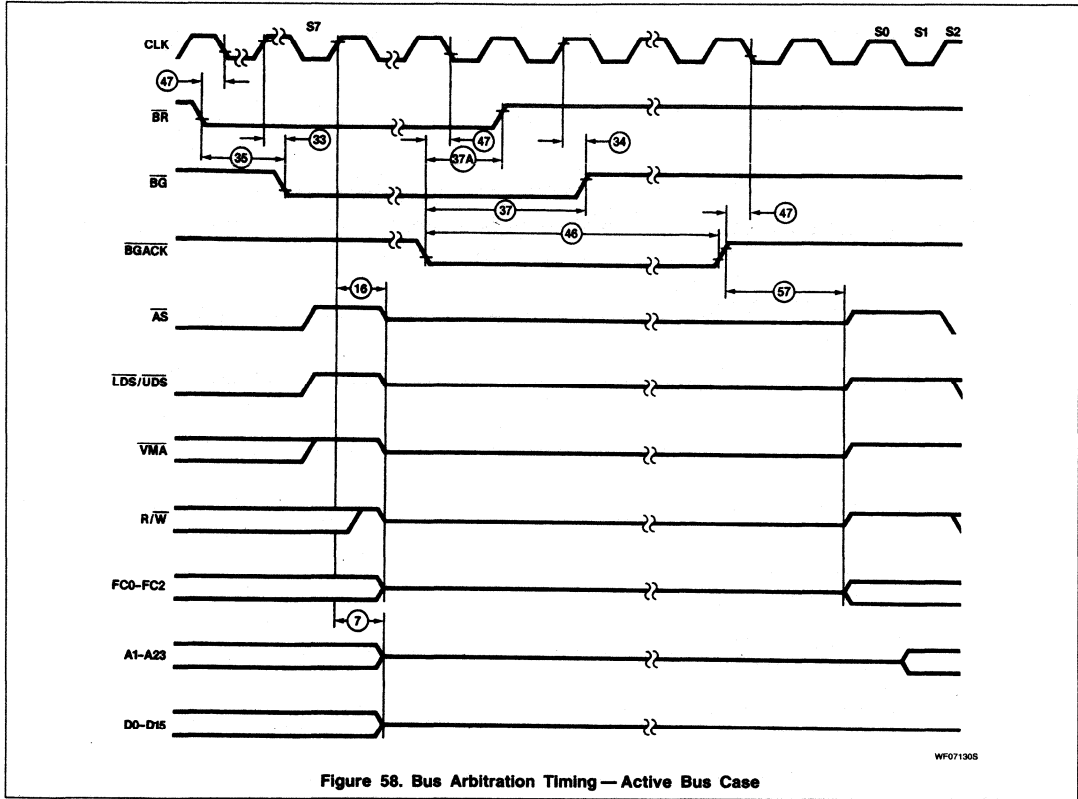

Figure 58. Bus Arbitration Timing — Active Bus Case

16-Bit Virtual Memory Microprocessor

SCN68010

These waveforms should only be referenced in regard to the edge-to-edge measurement of the timing specifications. They are not intended as a functional description of the input and output signals. Refer to other functional descriptions and their related diagrams for device operation.

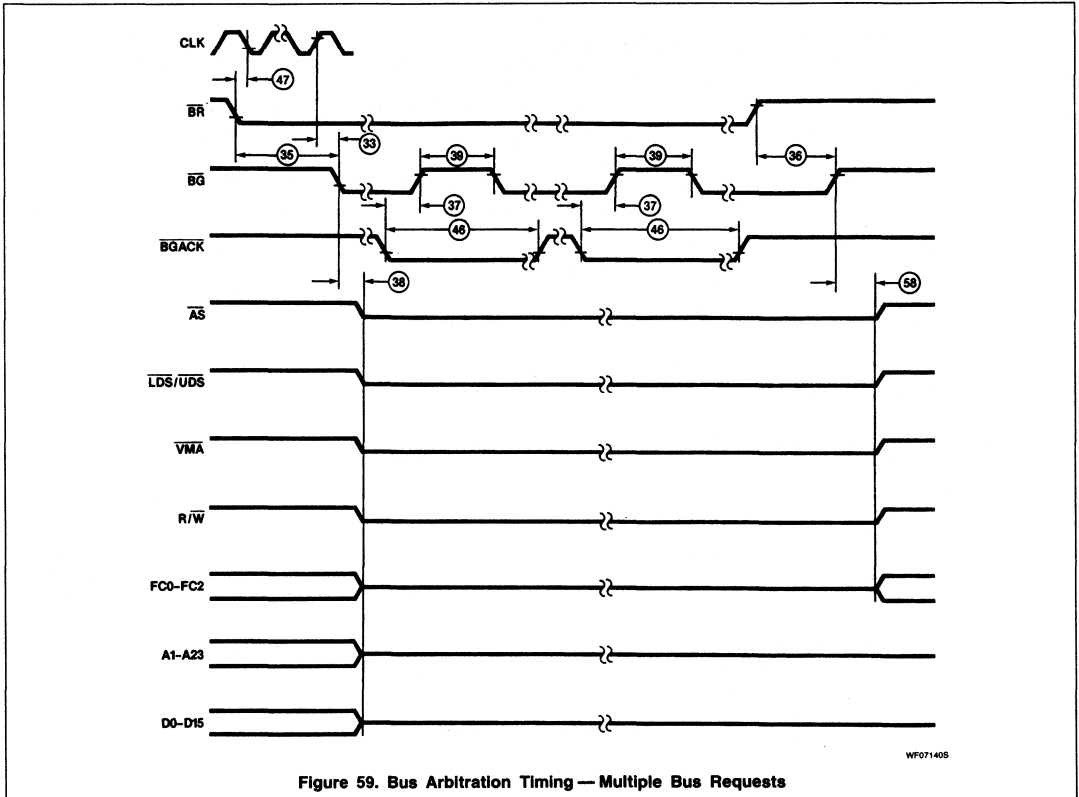

Figure 59. Bus Arbitration Timing — Multiple Bus Requests

# SCB68154 Interrupt Generator

Preliminary Specification

## Microprocessor Products

### DESCRIPTION

The Signetics SCB68154/8X825 Interrupt Generator provides an interface between an interrupting device and a system bus such as the VMEbus or VERSAbus<sup>®</sup>. Figure 1 shows a typical configuration of the SCB68154/8X825. The SCB68154/8X825 has three primary functions:

1. Generates bus interrupt requests.
2. Resides in the interrupt acknowledge daisy-chain.
3. Allows a status/ID byte (interrupt vector) to be supplied to the system if needed.

The SCB68154/8X825 has seven interrupt request levels, IRQ7N – IRQ1N, which are selected by using the interrupt request register. The local master writes to the interrupt request register to generate an interrupt request on any interrupt request level. The interrupt request register may be read to determine if an interrupt has been acknowledged. If a level with an interrupt request pending is acknowledged, the SCB68154/8X825 will allow a status/ID byte to be supplied to the system. Seven bits of the status/ID byte come from the interrupt vector register with the user externally supplying the LSB. If the SCB68154/8X825 does not have an interrupt on the level acknowledged, the SCB68154/8X825 will pass the interrupt acknowledge on via the interrupt acknowledge daisy-chain output. The user can enable all interrupt request levels and clear all interrupt request levels by setting specific bits in the interrupt vector register.

The SCB68154/8X825 was designed primarily for interface to the VMEbus. For more information regarding the protocol definitions, proper use, and application of this device, refer to the VMEbus Specification Manual.

### FEATURES

- Interrupts generator for VMEbus and VERSAbus systems
- Generates 7 bus interrupt requests
- Two internal registers for system control
- Interrupt enable and interrupt clear bits
- Allows status/ID byte to be supplied during interrupt acknowledge
- High-speed bipolar technology
- Single +5V supply

### PIN CONFIGURATION

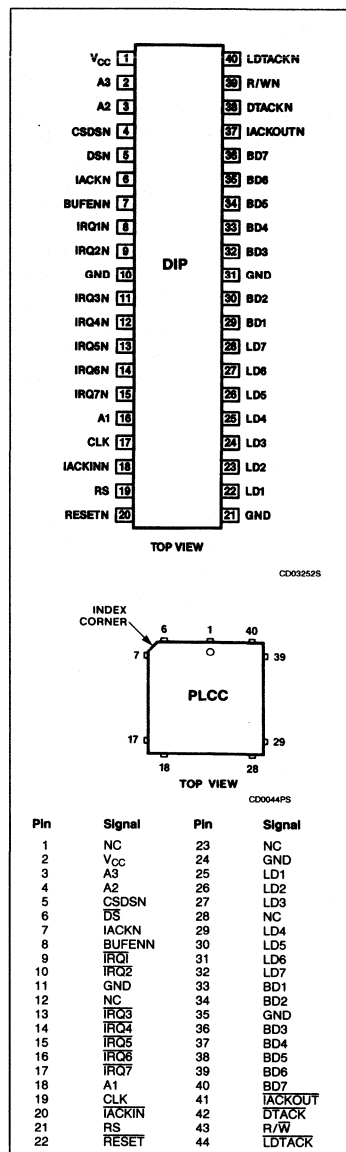

VERSAbus is a registered trademark of Motorola, Inc.

# Interrupt Generator

SCB68154

## ORDERING INFORMATION

PACKAGES	V <sub>CC</sub> = +5V ± 5%, T <sub>A</sub> = 0°C to +70°C
Ceramic DIP	SCB68154C2I40
Plastic DIP	SCB68154C2N40
Plastic LCC	SCB68154C2A44

## BLOCK DIAGRAM

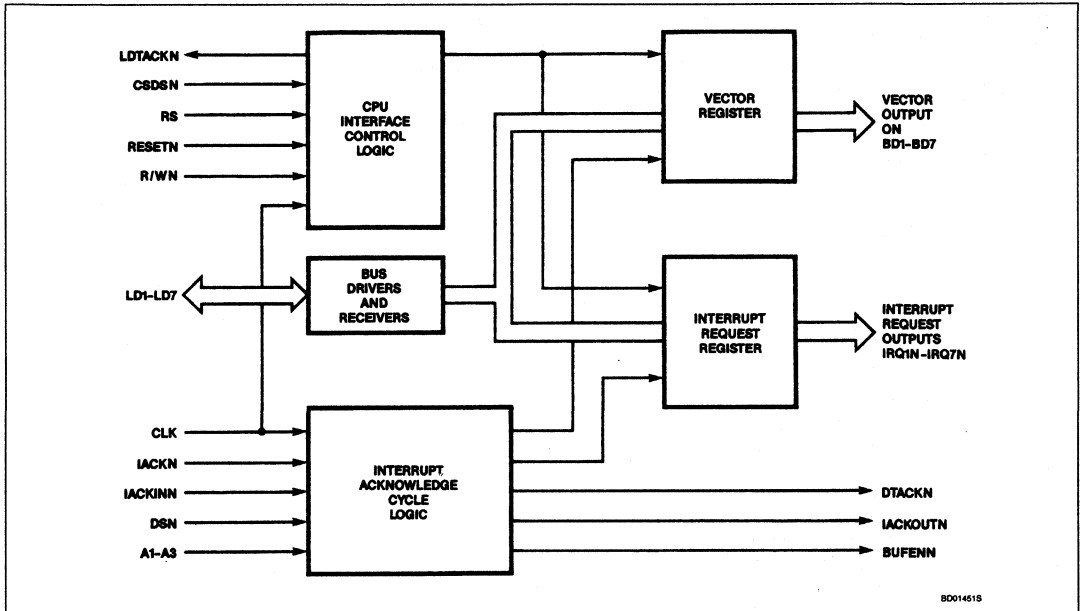

## Interrupt Generator

SCB68154

## PIN DESCRIPTION

MNEMONIC	PIN NO.	TYPE	NAME AND FUNCTION
V <sub>CC</sub>	1	I	<b>Supply Voltage:</b> +5V power supply
A1 – A3	16, 3, 2	I	<b>Address Lines:</b> Address inputs from system bus. The internal level being acknowledged is encoded on these inputs. A1 is LSB (least significant bit).
CSDSN	4	I	<b>Chip Select:</b> Active low chip select input for register I/O. This input must be qualified by the local master's data strobe prior to input (see Figure 1).
DSN	5	I	<b>Data Strobe:</b> Active low data strobe input from the system used to enable interrupt vector output.
IACKN	6	I	<b>Interrupt Acknowledge:</b> Active low interrupt acknowledge input from the system bus.
BUFENN	7	O	<b>Buffer Enable:</b> Active low totem pole output to enable the data buffer required to drive the outputs of the bus data pins (BD1 – BD7).
IRQ1N – IRQ7N	8, 9, 11 – 15	O	<b>Interrupt Request:</b> Active low totem pole system interrupt request output.
GND	10, 21, 31	I	<b>Ground</b>
CLK	17	I	<b>Clock:</b> Clock input (typically CPU clock).
IACKINN	18	I	<b>Interrupt Acknowledge In:</b> Active low interrupt acknowledge daisy-chain input.
RS	19	I	<b>Register Select:</b> Register select input.
RESETN	20	I	<b>Reset:</b> Active low input resets all internal registers, IACKOUTN, and IRQnN.
LD1 – LD7	22 – 28	I/O	<b>Local Data:</b> 3-State local data bus.
BD1 – BD7	29, 30, 32 – 36	O	<b>Bus Data:</b> 3-State data pins used for vector output.
IACKOUTN	37	O	<b>Interrupt Acknowledge Out:</b> Active low totem pole interrupt acknowledge daisy-chain output.
DTACKN	38	O	<b>Data Transfer Acknowledge:</b> Active low, totem pole output. This signal indicates that valid data is available on the bus during interrupt acknowledge cycle.
R/WN	39	I	<b>Read/Write:</b> Register read/write input. This signal specifies the data transfer cycle in process is to be either read or write.
LDTACKN	40	O	<b>Local Data Transfer Acknowledge:</b> Active low, open collector, data transfer acknowledge output to the local bus.

## FUNCTIONAL DESCRIPTION

## Typical Configuration

The SCB68154/8X825 provides a vehicle for interprocessor communications on an intelligent peripheral controller board, or a CPU board as shown in Figure 1. The local data pins (LD1 – LD7) serve as a local data bus. This allows the local master to access the Interrupt Generator's two internal registers. During an interrupt acknowledge, the SCB68154/8X825 will allow for a status/ID byte to be supplied to the system. The SCB68154/8X825 supplies seven of the eight needed status/ID bits. The user is allowed to externally supply the least significant bit (LSB), typically the system address line A1 of the status/ID byte. The IRQ1N – IRQ7N, DTACKN, and BD1 – BD7 outputs require external buffers to provide adequate drive to the system bus. BUFENN provides the output enable control for the data buffer that is required for BD1 – BD7.

## Register Selection

The SCB68154/8X825 has two internal registers which can be programmed for system control. They are the interrupt vector register and the interrupt request register. Figure 2 shows the programming model. Both registers can be read from as well as written to. The interrupt vector register (register R0) is selected by the register select (RS) input equal to 0. Setting bit 1 of register R0 enables all interrupt levels for the SCB68154/8X825. Writing a 1 to bit 2 of register R0 resets all interrupt levels in the interrupt request register as well as the IRQnN outputs. Subsequent interrupt requests will be honored. Bit 2 of R0 will always be read as 0. The high order bits, bits 7 – 3, of register R0 are the high order bits of the status/ID byte. The seven bit output of the status/ID byte are formed by concatenating the high order bits (bits 7 – 3) of register R0 with system bus address lines A3 and A2. Bus address lines A3 and A2 are output on BD2 and BD1 respectively.

The interrupt request register (R1) is selected by RS input equal to 1. Setting bit "n" in R1 will generate an interrupt on interrupt request level IRQnN. Any number (up to the maximum of seven) interrupt requests can be generated in a single access of R1.

The state of only those levels, which a 1 has been written to, is affected. Writing a 0 to any level does not change the current state of that level. For example, if IRQ1N is currently asserted, writing a 0 to bit 1 of R1 does not de-assert IRQ1N, nor clear bit 1 in R1.

Note that interrupt requests on the same level are not stackable. To generate another interrupt request on a level currently asserted, the user must wait until that level has been acknowledged, before generating another interrupt request on that level.

Since interrupts are acknowledged independently of the local CPU, the interrupt vector register should not be modified while interrupts are pending. Any attempt to modify the interrupt vector register, while interrupts are

# Interrupt Generator

# SCB68154

pending, could cause the status/ID byte to change while the interrupted master is reading it. This could cause the interrupted master to acquire an indeterminate vector. Therefore, the interrupt request register should be examined to make certain there are no interrupts pending before attempting to modify the interrupt vector register.

All data transfers between the local CPU and the SCB68154/8X825 are done using local data lines (LD1 – LD7), register select (RS), read/write (R/WN) and a chip select input (CSDSN). The SCB68154/8X825 supplies a local data transfer acknowledge (LDTACKN) to complete the transfer of data between the local CPU and itself.

### Interrupt/Interrupt Acknowledge

The SCB68154/8X825 generates the maximum defined seven bus interrupts, on the IRQ1N – IRQ7N outputs, in a VMEbus or VERSAbus system. An interrupted master will acknowledge only a single level of the seven

interrupt levels. To allow for multiple interrupters on the level acknowledged, VMEbus and VERSAbus systems use an interrupt acknowledge daisy-chain. The SCB68154/8X825 resides in this interrupt acknowledge daisy-chain.

When the system interrupt acknowledge (IACKN) is asserted, the interrupt acknowledge daisy-chain starts at the first slot in the system bus. The level being acknowledged is specified by the interrupted master on address lines A1 – A3. The system bus interface on the SCB68154/8X825 is initiated only if IACKN, interrupt acknowledge daisy-chain in (IACKINN), and data strobe 0 (DS0N) are all received asserted. If the system bus interface is initiated and the SCB68154/8X825 has an interrupt request on the level specified, it will not pass the daisy-chain signal on. It will, instead, clear the interrupt request level acknowledged, IRQnN, as well as the appropriate bit in the interrupt request register. It will also assert buffer enable (BUFENN), place

seven bits of the status/ID byte on the bus data outputs (BD1 – BD7) and assert data transfer acknowledge (DTACKN).

If the system bus interface is initiated, but the SCB68154/8X825 has no interrupt request on the level being acknowledged, it will pass the daisy-chain input (IACKINN) on via the interrupt acknowledge out (IACKOUTN).

### Arbitration

The system bus interface, as well as the local master interface, are independent processes. Either can be initiated at any time, without respect to the other. The SCB68154/8X825 will arbitrate between the processes, allowing proper system operation without any degradation in performance.

### Reset

When RESETN is asserted, the SCB68154/8X825 drives the outputs IRQnN and IACKOUTN high. It also resets the interrupt request and the interrupt vector registers.

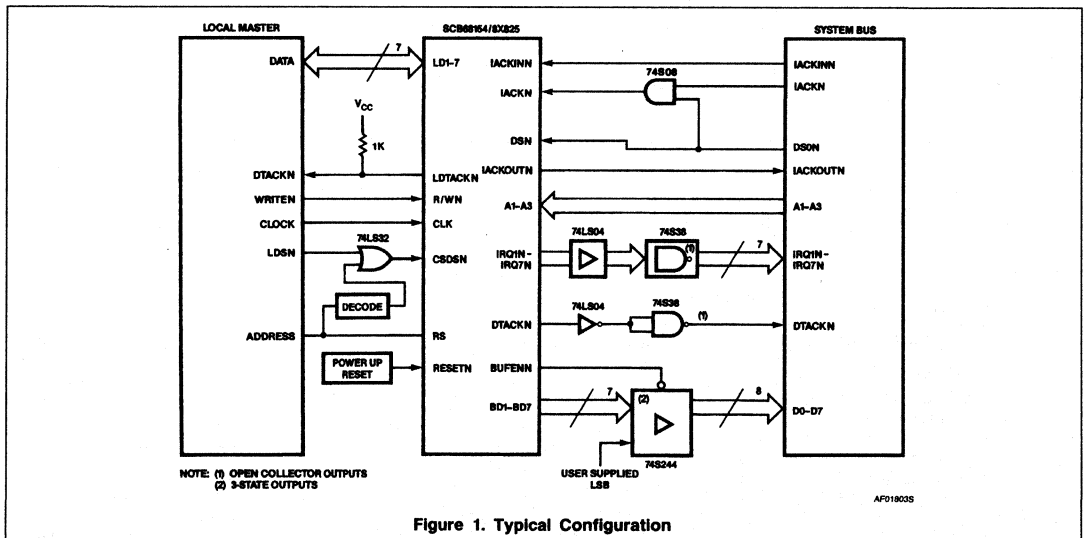

Figure 1. Typical Configuration

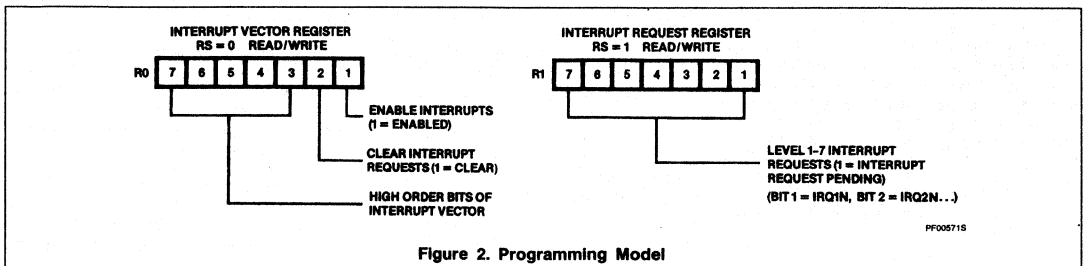

Figure 2. Programming Model

## Interrupt Generator

SCB68154

ABSOLUTE MAXIMUM RATINGS<sup>1</sup>

SYMBOL	PARAMETER	RATING	UNIT
$T_A$	Operating ambient temperature <sup>2</sup> range	0 to +70	°C
$T_{STG}$	Storage temperature range	-65 to +150	°C
$V_{CC}$	Supply voltage <sup>3</sup> range	-0.5 to +7.0	V
$V_{IN}$	Input voltage <sup>3</sup> range	-0.5 to +5.5	V
$V_{OUT}$	Voltage applied to output in off-state <sup>3</sup>	-0.5 to +5.5	V

DC ELECTRICAL CHARACTERISTICS  $T_A = 0^\circ\text{C}$  to  $+70^\circ\text{C}$ ,  $V_{CC} = +5\text{V} \pm 5\%$ <sup>4, 5</sup>

SYMBOL	PARAMETER	TEST CONDITIONS	LIMITS		UNIT
			Min	Max	
$V_{CC}$	Supply voltage		4.75	5.25	V
$V_{IL}$	Input low voltage			0.8	V
$V_{IH}$	Input high voltage		2		V
$I_{IL}$	Input low current	$V_{CC} = 5.25\text{V}$ , $V_{IL} = 0.4\text{V}$		-410	$\mu\text{A}$
$I_{IH}$	Input high current	$V_{CC} = 5.25\text{V}$ , $V_{IH} = 2.7\text{V}$		20	$\mu\text{A}$
$I_{OS}$	Short circuit output current	$V_{CC} = 5.25\text{V}$ , $V_{OUT} = 0\text{V}$ Other outputs not grounded	-15	-100	mA
$I_{OZL}$	High-Z low output current BD1 - BD7	$V_{CC} = 5.25\text{V}$ , $V_{OL} = 0.5\text{V}$		-20	$\mu\text{A}$
$I_{OZH}$	High-Z high output current BD1 - BD7	$V_{CC} = 5.25\text{V}$ , $V_{OH} = 2.5\text{V}$		20	$\mu\text{A}$
$V_{OL}$	Output low voltage LDTACKN	$V_{CC} = 4.75\text{V}$ , $I_{OL} = 20\text{mA}$		0.5	V
$V_{OH}$	Output high voltage All other outputs	$V_{CC} = 4.75\text{V}$ , $I_{OL} = 8\text{mA}$ $V_{CC} = 4.75\text{V}$ , $I_{OH} = -400\mu\text{A}$	2.5		V
$I_{CEX}$	Open collector leakage current LDTACKN	$V_{CC} = 4.75\text{V}$ , $V_{OUT} = 4.75\text{V}$		100	$\mu\text{A}$
$I_I$	Input leakage current	$V_{CC} = 5.25\text{V}$ , $V_{IN} = 5.25\text{V}$		100	$\mu\text{A}$
$V_{IC}$	Input clamp voltage	$V_{CC} = 4.75\text{V}$ , $I_{IN} = -10\text{mA}$	-1.2		V
$I_{CC}$	Supply current	$V_{CC} = 5.25\text{V}$ , $V_{IN} = 0\text{V}$		130	mA

## NOTES:

- Stresses above those listed under Absolute Maximum Ratings may cause permanent damage to the device. This is stress rating only and functional operation of the device at these or at any other condition above those indicated in the operation section of this specification is not implied.
- For operating at elevated temperatures, the device must be derated based on  $+150^\circ\text{C}$  maximum junction temperature and thermal resistance of  $60^\circ\text{C}/\text{W}$  junction to ambient for ceramic package ( $116^\circ\text{C}/\text{W}$  for plastic package).
- This product includes circuitry specifically designed for the protection of its internal devices from damaging effects of excessive static charge. Nonetheless, it is suggested that conventional precautions be taken to avoid applying any voltages larger than the rated maxima.
- Parameters are valid over specified temperature range.
- All voltage measurements are referenced to ground (GND). For testing, all inputs swing between 0.4V and 2.4V with a transition time of 3ns maximum and output voltages are checked at 0.8V and 2V.
- If the falling edge of IACKINN occurs last, then  $t_{ADIK}$  is valid. If the falling edge of DSN occurs last, then  $t_{ADDS}$  is valid. If the falling edges of IACKINN and DSN occur simultaneously then either  $t_{ADDS}$  or  $t_{ADIK}$  is valid.
- If the falling edge of IACKINN occurs last, then  $t_{KBF}$  is valid. If the falling edge of DSN occurs last, then  $t_{DSBF}$  is valid. If the falling edges of IACKINN and DSN occur simultaneously then either  $t_{KBF}$  or  $t_{DSBF}$  is valid.
- If the falling edge of IACKINN occurs last, then  $t_{RA1}$  is valid. If DSN occurs last, then  $t_{RA2}$  is valid. If the falling edges of both IACKINN and DSN occur simultaneously then either  $t_{RA1}$  or  $t_{RA2}$  is valid.
- True only if no request pending on levels being acknowledged. If the falling edge of IACKINN occurs last, then  $t_{YO1}$  is valid. If the falling edge of DSN occurs last then  $t_{YO2}$  is valid. If the falling edges of both IACKINN and DSN occur simultaneously then either  $t_{YO1}$  or  $t_{YO2}$  is valid.
- If the rising edge of IACKN occurs first, then  $t_{DT}$  is valid. If the rising edge of DSN occurs first then  $t_{SDT}$  is valid. If the rising edges of both IACKN and DSN occur simultaneously, then either  $t_{DT}$  or  $t_{SDT}$  is valid.
- If the rising edge of IACKN occurs first then  $t_{TST}$  is valid. If the rising edge of DSN occurs first then  $t_{DST}$  is valid. If the rising edges of both IACKN and DSN occur simultaneously then either  $t_{TST}$  or  $t_{DST}$  is valid.
- If the rising edge of IACKN occurs first, then  $t_{BF}$  is valid. If the rising edge of DSN occurs first then  $t_{DBF}$  is valid. If the rising edges of both IACKN and DSN occur simultaneously, then either  $t_{BF}$  or  $t_{DBF}$  is valid.
- If the rising edge of IACKN occurs first then  $t_{DTK}$  is valid. If the rising edge of DSN occurs first then  $t_{DDTK}$  is valid. If the rising edges of both IACKN and DSN occur simultaneously, then either  $t_{DTK}$  or  $t_{DDTK}$  is valid.
- True only if no request pending on level being acknowledged. If the rising edge of IACKN occurs first then  $t_{OUT}$  is valid. If the rising edge of DSN occurs first then  $t_{OOUT}$  is valid. If the rising edge of both IACKN and DSN occur simultaneously then either  $t_{OUT}$  or  $t_{OOUT}$  is valid.
- $t_{TST}$  is always greater than or equal to  $t_{DTH}$ .

## Interrupt Generator

SCB68154

AC ELECTRICAL CHARACTERISTICS  $T_A = 0^\circ\text{C}$  to  $+70^\circ\text{C}$ ,  $V_{CC} = +5\text{V} \pm 5\%^{4, 5}$ 

SYMBOL	PARAMETER	TENTATIVE LIMITS		UNIT
		Min	Max	
<b>Register read (see Figure 3)</b>				
$t_{RSS}$	RS valid to CSDSN low setup time	0		ns
$t_{RWS}$	R/WN to CSDSN low setup time	0		ns
$t_{DTV}$	LDTACKN low to LD1 – 7 valid	5.4	19.4	ns
$t_{DTCS}$	LDTACKN low to CSDSN high	0		ns
$t_{RSH}$	CSDSN high to RS valid hold time	0		ns
$t_{RWH}$	CSDSN high to R/WN high hold time	0		ns
$t_{DTH}$	CSDSN high to LD1 – 7 valid hold time	11.5	33.5	ns
$t_{TST}^{15}$	CSDSN high to LD1 – 7 3-State	11.5	34.5	ns
$t_{CSDT}$	CSDSN high to LDTACKN high	9.2	27.2	ns
$t_{CSH}$	CSDSN high time	20		ns
$t_{ACCR}$	CSDSN low to LDTACKN low read access time	$t_{CKPD} \div 2 + 12.5$	$3t_{CKPD} \div 2 + 40.3$	ns
<b>Register write (see Figure 4)</b>				
$t_{RSS}$	RS valid to CSDSN low setup time	0		ns
$t_{RWS2}$	R/WN low to CSDSN low setup time	0		ns
$t_{DS}$	LD1 – LD7 valid to CSDSN low setup time	0		ns
$t_{RSH}$	CSDSN high to RS valid hold time	0		ns
$t_{RWH2}$	CSDSN high to R/WN low hold time	0		ns
$t_{DH}$	CSDSN high to LD1 – LD7 valid	0		ns
$t_{CSDT}$	CSDSN high to LDTACKN high	9.2	27.2	ns
$t_{DTCS}$	LDTACKN low to CSDSN high	0		ns
$t_{IRQ}$	LDTACKN low to IRQnN low	1.2	8.2	ns
$t_{ACCW}$	CSDSN low to LDTACKN low write access time	$t_{CKPD} \div 2 + 13.3$	$3t_{CKPD} \div 2 + 40.3$	ns
$t_{CSH}$	CSDSN high time	20		ns
<b>Interrupt acknowledge (see Figure 5)</b>				
$t_{IKDS}$	IACKN low to DSN low	0		ns
$t_{ADDS}^6$	A1 – A3 valid to DSN low setup	0		ns
$t_{ADIK}^6$	A1 – A3 valid to IACKINN low setup	0		ns
$t_{IKBF}^7$	IACKINN low to BUFENN low	$t_{CKPD} + 18.3$	$3t_{CKPD} \div 2 + 29.2$	ns
$t_{DSBF}^7$	DSN low to BUFENN low	$t_{CKPD} + 18.3$	$3t_{CKPD} \div 2 + 29.2$	ns
$t_{IRA1}^8$	IACKINN low to IRQnN high	$t_{CKPD} + 12.5$	$3t_{CKPD} \div 2 + 29.2$	ns
$t_{IRA2}^8$	DSN low to IRQnN high	$t_{CKPD} + 29.2$	$3t_{CKPD} \div 2 + 29.2$	ns
$t_{DYO1}^9$	IACKINN low to IACKOUTN	$t_{CKPD} + 11.2$	$3t_{CKPD} \div 2 + 29.2$	ns
$t_{DYO2}^9$	DSN low to IACKOUTN low	$t_{CKPD} + 11.2$	$3t_{CKPD} \div 2 + 29.2$	ns



## Interrupt Generator

SCB68154

## AC ELECTRICAL CHARACTERISTICS (Continued)

SYMBOL	PARAMETER	TENTATIVE LIMITS		UNIT
		Min	Max	
$t_{BFBD}$	BUFENN low to BD1 – BD7 valid	3.2	38.2	ns
$t_{BFDT}$	BUFENN low to DTACKN low	38.2	50	ns
$t_{ADRH}$	DTACKN low to A1 – A3 valid hold time	0		ns
$t_{DTDS}$	DTACKN low to DSN high	0		ns
$t_{DTIK}$	DTACKN low to IACKN high	0		ns
$t_{IDT}^{10}$	IACKN high to BD1 – BD7 valid hold time	3	8.4	ns
$t_{DSDT}^{10}$	DSN high to BD1 – BD7 valid hold time	3	8.4	ns
$t_{ITST}^{11}$	IACKN high to BD1 – BD7 3-State	3	9.1	ns
$t_{DTST}^{11}$	DSN high to BD1 – BD7 3-State	3	9.1	ns
$t_{DBF}^{12}$	DSN high to BUFENN high	12.2	32.2	ns
$t_{IBF}^{12}$	IACKN high to BUFENN high	12.2	32.2	ns
$t_{DDTK}^{13}$	DSN high to DTACKN high	12.2	32.2	ns
$t_{IDTK}^{13}$	IACKN high to DTACKN high	12.2	32.2	ns
$t_{IOUT}^{14}$	IACKN high to IACKOUTN high	6.2	17.2	ns
$t_{DOUT}^{14}$	DSN high to IACKOUTN high	6.2	17.2	ns
$t_{IAKH}$	IACKN high time	20		ns
$t_{IINH}$	IACKN high to IACKINN high	0		ns
$t_{IKIN}$	IACKN low to IACKINN low	0		ns
<b>Reset timing (see Figure 6)</b>				
$t_{RST}$	RESETN low time	51		ns
<b>Clock timing (see Figure 7)</b>				
$t_{CKH}$	Clock high	45		ns
$t_{CKPD}$	Clock period	90		ns

2





# Interrupt Generator

## SCB68154

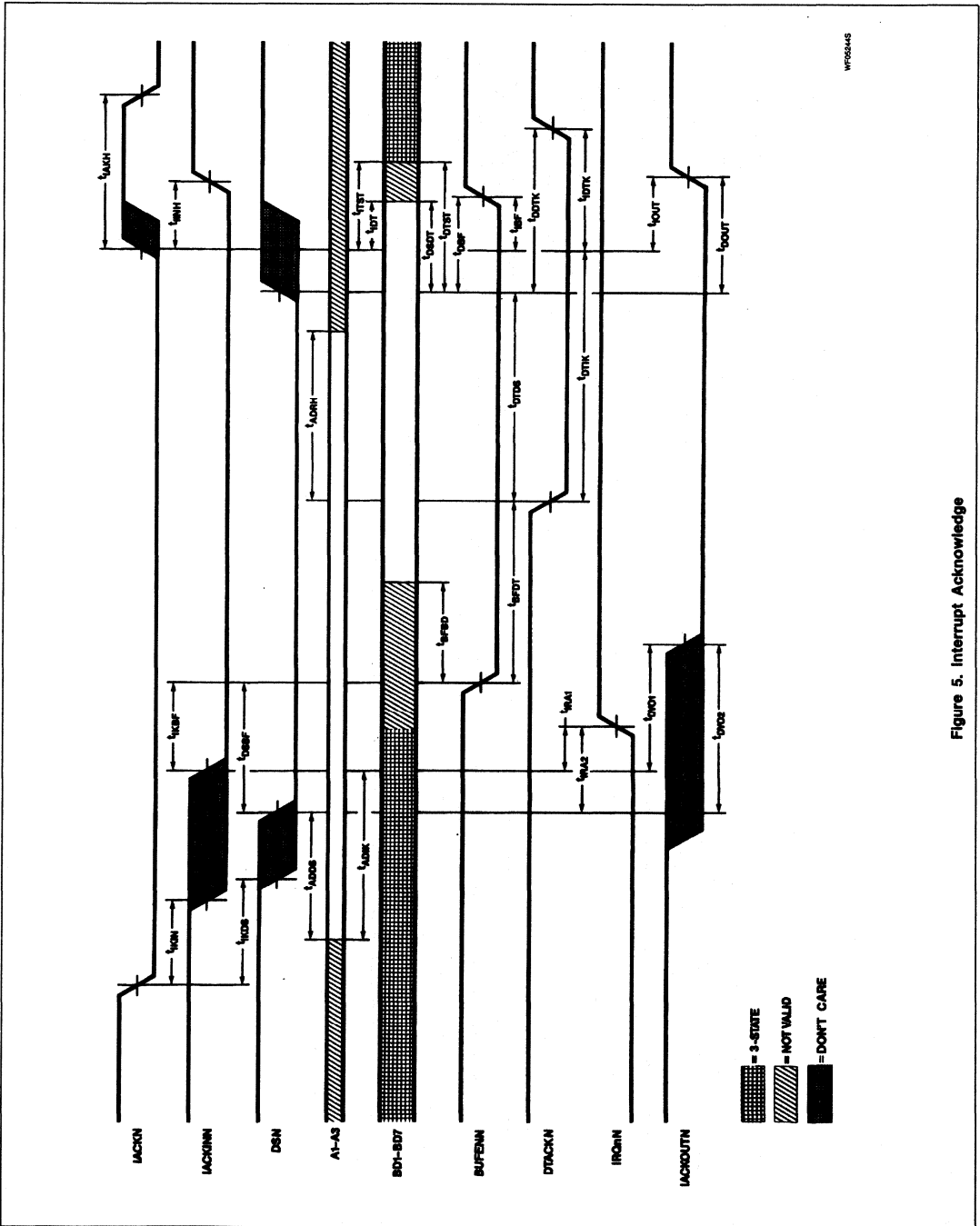
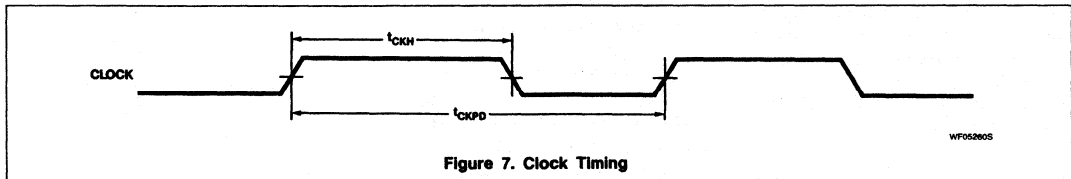
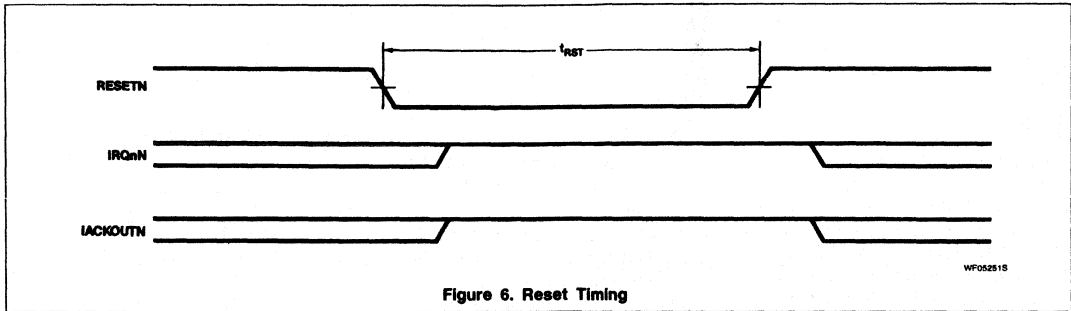

Figure 5. Interrupt Acknowledge

# Interrupt Generator

# SCB68154

2



# SCB68155 Interrupt Handler

*Preliminary Specification*

## Microprocessor Products

### DESCRIPTION

The Signetics SCB68155/8X824 is an asynchronous interrupt handler for VMEbus and VERSAbus® systems. Up to 14 interrupts are prioritized by the SCB68155/8X824 to one of seven levels and are output on the interrupt priority level lines (IPL0N – IPL2N). The SCB68155/8X824 prioritizes the interrupts in the following manner: local bus requests over system bus requests with the non-maskable interrupt (NMIN) considered the highest priority local interrupt (NMIN over IRQ7N, then LRQ6N – LRQ1N over IRQ6N – IRQ1N).

The local interrupt requests can be programmed to be either active high or low, and either edge or level sensitive. The system bus interrupt requests are always active low and level sensitive. The non-maskable interrupt is always negative edge-triggered.

During a local interrupt acknowledge sequence, two modes of response are available: vectored mode or device-supplies-the vector mode.

For system bus responses, the SCB68155/8X824 works with a bus requester (for example, the Signetics SCB68172 VMEbus Controller), to acquire a status/ID byte (interrupt vector) from the system.

The SCB68155/8X824 was designed primarily for interface to the VMEbus. For more information regarding the protocol definitions, proper use, and application of this device, refer to the VMEbus Specification Manual.

### FEATURES

- Asynchronous interrupt handler for VMEbus and VERSAbus systems
- Receives and prioritizes non-maskable, six local and seven system bus interrupts
- Interrupts may be polled in lieu of real-time operation
- Programmable local interrupt response
- Works with the SCB68172 to acquire status/ID byte (vector) during bus interrupt acknowledge
- Complete device status, including last interrupt acknowledged
- High-speed bipolar technology

### PIN CONFIGURATION

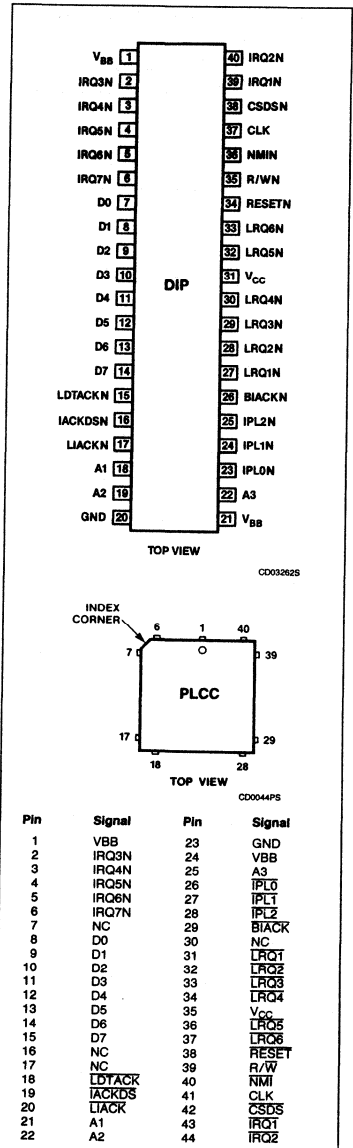

# Interrupt Handler

SCB68155

## ORDERING INFORMATION

PACKAGES	V <sub>CC</sub> = +5V ± 5%, T <sub>A</sub> = 0°C to +70°C
Ceramic DIP	SCB68155CAI40
Plastic DIP	SCB68155CAN40
Plastic LCC	SCB68155CA44

## BLOCK DIAGRAM

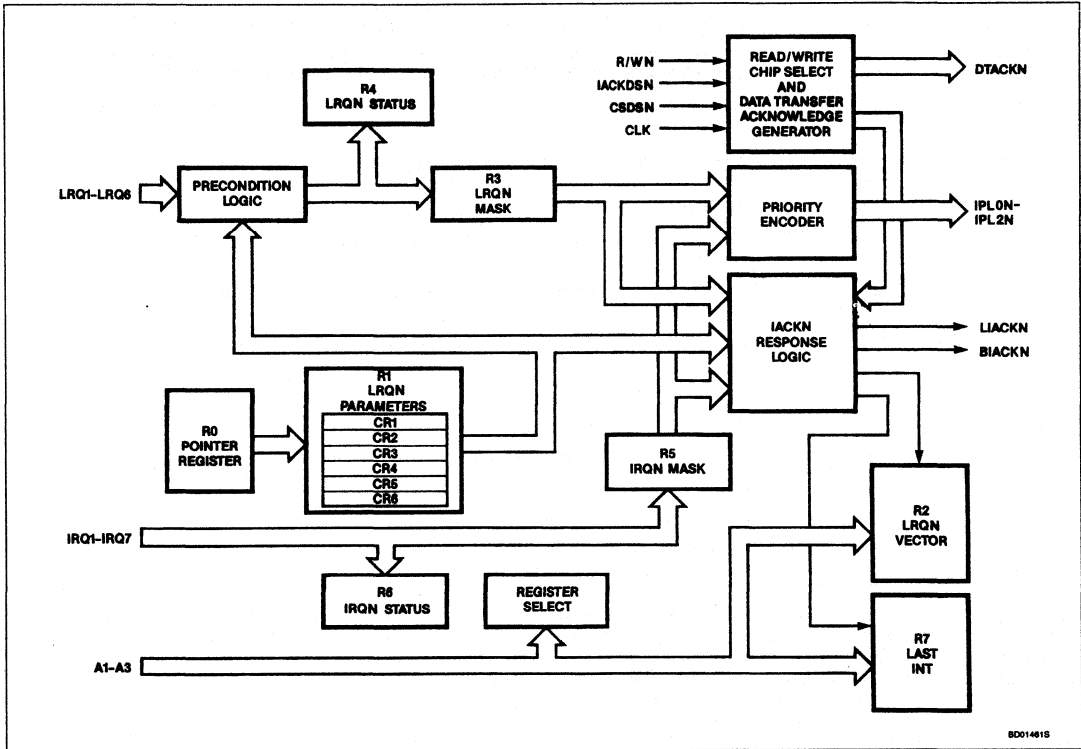

2

# Interrupt Handler

SCB68155

## PIN DESCRIPTION

MNEMONIC	PIN NO.	TYPE	NAME AND FUNCTION
V <sub>BB</sub>	1, 21	I	<b>Supply Voltage:</b> Supply voltage for internal gates.
IRQ1N – IRQ7N	39, 40, 2 – 6	I	<b>Bus Interrupt Request:</b> Active low inputs for bus generated interrupts.
D0 – D7	7 – 14	I/O	<b>Bus Data:</b> 3-State local data bus.
LDTACKN	15	O	<b>Local Data Transfer Acknowledge:</b> Active low, open collector output. Indicates that valid data is available on the local data bus during interrupt acknowledge cycle or data transfer cycle.
IACKDSN	16	I	<b>Interrupt Acknowledge:</b> Active low interrupt acknowledge input from the local master. This signal must be qualified by the local master's data strobe prior to input.
LIACKN	17	O	<b>Local Interrupt Acknowledge:</b> Active low interrupt acknowledge totem pole output to the local interrupting devices.
A1 – A3	18, 19, 22	I	<b>Address Lines:</b> Address inputs from local master.
GND	20	I	<b>Ground</b>
IPL0N – IPL2N	23 – 25	O	<b>Interrupt Priority Level:</b> Active low totem-pole outputs to the local master. The priority level of the interrupt request is encoded on these outputs.
BIACKN	26	O	<b>Bus Interrupt Acknowledge:</b> Active low interrupt acknowledge totem-pole output to the system bus.
LRQ1N – LRQ6N	27 – 30, 32, 33	I	<b>Local Interrupt Request:</b> User can define the active state of these inputs.
V <sub>CC</sub>	31	I	<b>Supply Voltage:</b> +5V power supply.
RESETN	34	I	<b>Reset:</b> Active low input reset.
R/WN	35	I	<b>Read/Write:</b> This signal specifies the data transfer cycle to be either read or write.
NMIN	36	I	<b>Non-Maskable Interrupt:</b> Active low highest priority interrupt.
CLK	37	I	<b>Clock:</b> Clock input (typically CPU clock).
CSDSN	38	I	<b>Chip Select:</b> Active low chip select input for register I/O. This input must be qualified by the local master's data strobe prior to input.

## REGISTERS

The SCB68155/8X824 contains eight internal registers (R0 – R7) accessible to the local master. There are also six sub-registers contained in register R1. Register R0 specifies which sub-register is to be accessed in R1. Register R2 stores the interrupt vector for

vectored mode responses. Register R3 and R5 are the interrupt mask registers for the local and system bus interrupts respectively. Registers R4 and R6 are the status registers for local and bus interrupts respectively, allowing all interrupts to be polled. Register R7 can be read by the local master to determine the last interrupt acknowledged.

All data transfers between the SCB68155/8X824 and the local master are done using the local data bus (D0 – D7), address bus (A1 – A3), a chip select (CSDSN) and a read/write (R/WN) input.

### Register R0 — A3A2A1 = 000

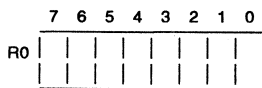

Pointer register (write only).

Bit 0 – 2 of R0 specify which control sub-register CR1 – CR6 during an access of R1. During register I/O, bits 7 – 3 will read as 0.

B2 – B1 – B0

- |            |           |
|------------|-----------|
| 000 – none | 100 – CR4 |
| 001 – CR1  | 101 – CR5 |
| 010 – CR2  | 110 – CR6 |
| 011 – CR3  | 111 none  |



# Interrupt Handler

SCB68155

**2**

**Register R1 — A3A2A1 = 001**

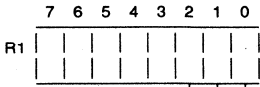

Control registers CR1 – CR6 (read or write).  
 These six registers program the function of the local interrupt requests (LRQ1N – LRQ6N). (CR1 programs LRQ1N, CR2 programs LRQ2N, etc). During register I/O, bits 7 – 3 will be read as 0.

- LRQnN active state (high/low) (1 = active high)
- LRQnN edge/level sensitive (1 = edge sensitive)
- LRQnN vector enable (1 = enabled)

**Register R2 — A3A2A1 = 010**

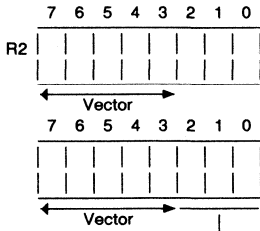

LRQ vector (read or write).  
 Bits 7 – 3 of this register are the top five bits of the local interrupt vector. During register I/O, bits 2 – 0 will be read as zeros.

LRQ vector output during local interrupt acknowledge (If vector enable = 1).

- 001 – LRQ1N
- 010 – LRQ2N
- 011 – LRQ3N
- 100 – LRQ4N
- 101 – LRQ5N
- 110 – LRQ6N
- 111 – NMIN

**Register R3 — A3A2A1 = 011**

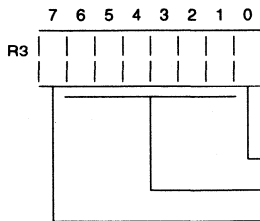

LRQ mask (read or write).  
 This register allows the user to mask local interrupts. It also enables vectored response for NMIN.

- NMIN Vector enable (1 = enabled)
- LRQN 1 – 6 mask (1 = interrupt enabled)
- NMIN mask (1 = NMIN enabled)
- Bit 1 = LRQ1N
- Bit 2 = LRQ2N
- Bit 3 = LRQ3N
- Bit 4 = LRQ4N
- Bit 5 = LRQ5N
- Bit 6 = LRQ6N
- Bit 7 = NMIN

# Interrupt Handler

SCB68155

**Register R4 — A3A2A1 = 100**

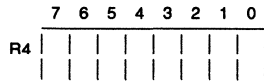

LRQ status (read only).

Local interrupts can be polled through this register. During register I/O, bit 0 will be read as a 0.

- |               |               |
|---------------|---------------|
| Bit 1 = LRQ1N | Bit 5 = LRQ5N |
| Bit 2 = LRQ2N | Bit 6 = LRQ6N |
| Bit 3 = LRQ3N | Bit 7 = NMIN  |
| Bit 4 = LRQ4N |               |

LRQN status (1 = interrupt pending)  
 NMIN status (1 = interrupt pending)

**Register R5 — A3A2A1 = 101**

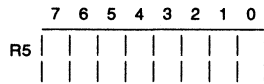

IRQ mask (read or write).

This register allows the user to mask system bus interrupts. During register I/O, bit 0 will be read as a 0.

- |               |               |
|---------------|---------------|
| Bit 1 = IRQ1N | Bit 5 = IRQ5N |
| Bit 2 = IRQ2N | Bit 6 = IRQ6N |
| Bit 3 = IRQ3N | Bit 7 = IRQ7N |
| Bit 4 = IRQ4N |               |

(1 = interrupt enabled)

**Register R6 — A3A2A1 = 110**

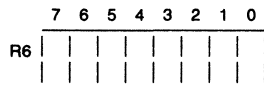

IRQ status (read only).

System bus interrupts can be polled through this register. During register I/O, bit 0 will be read as 0.

- |               |               |
|---------------|---------------|
| Bit 1 = IRQ1N | Bit 5 = IRQ5N |
| Bit 2 = IRQ2N | Bit 6 = IRQ6N |
| Bit 3 = IRQ3N | Bit 7 = IRQ7N |
| Bit 4 = IRQ4N |               |

IRQN status (1 = interrupt pending)

**Register R7 — A3A2A1 = 111**

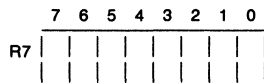

Last interrupt acknowledged (read only).

This register can be read by the local CPU to determine the last interrupt acknowledged. During register I/O, bits 7-4 will be read as 0.

- |              |              |
|--------------|--------------|
| 0000 - none  | 1000 - none  |
| 0001 - IRQ1N | 1001 - LRQ1N |
| 0010 - IRQ2N | 1010 - LRQ2N |
| 0011 - IRQ3N | 1011 - LRQ3N |
| 0100 - IRQ4N | 1100 - LRQ4N |
| 0101 - IRQ5N | 1101 - LRQ5N |
| 0110 - IRQ6N | 1110 - LRQ6N |
| 0111 - IRQ7N | 1111 - NMIN  |

# Interrupt Handler

# SCB68155

2

## FUNCTIONAL OPERATION

### Typical Configuration

The SCB68155/8X824 can handle interrupts from 14 sources: seven bus interrupt requests generated on the IRQ1N – IRQ7N inputs, six local interrupt sources generated on the LRQ1N – LRQ6N inputs, and one non-maskable interrupt which may originate locally or from the system (such as the system's AC fail signal). All interrupts are encoded to one of seven levels and output on the IPL0N – IPL2N lines. Table 1 shows how the SCB68155/8X824 encodes the interrupts.

BIACKN is the bus interrupt acknowledge signal which is asserted during a bus interrupt acknowledge sequence. BIACKN can be used to get the associated bus requester (for example, the Signetics SCB68172), to acquire an interrupt vector from the system bus. Figure 1 shows a typical SCB68155/8X824-SCB68172 system configuration.

LIACKN is the local interrupt acknowledge signal which is asserted during a local interrupt acknowledge sequence. Figure 2 shows a typical configuration for the SCB68155/8X824.

### Non-Maskable Interrupt (NMI)

The highest priority interrupt request is the non-maskable interrupt (NMIN). It is an active low, negative edge-triggered interrupt. NMIN is considered by the SCB68155/8X824 to be the highest priority local interrupt, however, the user is not restricted to having it represent a local device. When the local master responds to an NMIN, bit 7 in the LRQ status register R4 is cleared to 0.

Both vectored and device-supplies-the-vector modes are available with NMIN. However, it is recommended that the SCB68155/8X824's response to an NMIN be a vectored mode interrupt acknowledge.

### Local Interrupts

The SCB68155/8X824 can handle interrupts generated by local devices through its six local interrupt request lines (LRQ1N – LRQ6N). The local interrupt requests are prioritized with LRQ6N being the

highest priority, and LRQ1N the lowest priority.

The response of the SCB68155/8X824 to an acknowledge of a local interrupt can be selected by means of the SCB68155/8X824's R1 register. Pointer register R0 points to one of the six control sub-registers when accessing register R1. The six control registers (CR1 – CR6) in register R1 define the functions of the six local interrupt requests (LRQ1N – LRQ6N).

#### Control Register 'n' Bit 0

Selects local interrupt requests 'n' (LRQnN), to be either low or high. Bit 0 = 1 defines active state to be high.

#### Control Register 'n' Bit 1

Selects local interrupt request 'n', to be either edge or level sensitive. Bit 1 = 1 defines LRQnN to be edge sensitive.

#### Control Register 'n' Bit 2

Selects either vectored mode or device-supplies-the-vector mode response. Bit 2 = 1 enables vectored mode operation for LRQnN.

Two modes of operation for a local interrupt response are possible; vectored mode and device-supplies-the-vector mode. In vectored mode, the SCB68155/8X824 supplies the interrupt vector to the local CPU and asserts LDTACKN to complete the transfer. In the device-supplies-the-vector mode, the local interrupting device supplies its own interrupt vector and asserts LDTACKN to complete the transfer.

The vector register R2 allows the user to program the five most significant bits (bits 7 – 3) of the interrupt vector supplied in vectored mode. During a vectored local interrupt acknowledge cycle, the upper five bits of the vector register are concatenated with a 3-bit interrupt level (address lines A3 = B2 of the vector, A2 = B1 and A1 = B0). This forms the unique vector for the local interrupt request level being acknowledged.

The local interrupt request mask register R3 allows the user to selectively enable local interrupt requests by setting appropriate bits in the register.

The current state of the local interrupt requests can be determined by the local master by reading the local interrupt status register R4.

### Local Interrupt Acknowledge

An interrupt acknowledge, by the local CPU, is signified by the assertion of the interrupt acknowledge input (IACKDSN). The SCB68155/8X824 responds by reading the three address lines (A1 – A3) to determine what level is being acknowledged. If a local interrupt is the highest priority interrupt pending on the level acknowledged, the SCB68155/8X824 will respond as though it is programmed for that level.

If vectored mode is programmed, the SCB68155/8X824 will assert the local interrupt acknowledge (LIACKN) and place the interrupt vector on the local data bus. To complete the transfer of the vector to the local CPU, the SCB68155/8X824 asserts the local data transfer acknowledge signal (LDTACKN).

If device-supplies-the-vector mode is programmed, the SCB68155/8X824 asserts the local interrupt acknowledge signal (LIACKN). The interrupting device is then allowed to place its own vector on the local data bus and assert LDTACKN.

When a local interrupt is acknowledged by the local master, the appropriate bit in the LRQ status register R4 is cleared to 0.

### Bus Interrupts

The VMEbus specification defines a maximum of seven interrupt levels. The SCB68155/8X824 can handle seven system bus interrupts through its IRQ1N – IRQ7N lines. Bus interrupt request are active low level sensitive, and prioritized with IRQ7N being the highest priority and IRQ1N the lowest priority. The bus mask control register R5 allows the user to selectively enable bus interrupt requests by setting appropriate bits in the register. The local CPU can read the bus interrupt status register R6 to determine the current state of the bus interrupt requests.

### Bus Interrupt Acknowledge

The local CPU asserts the interrupt acknowledge signal (IACKDSN) to signify an interrupt acknowledge. The SCB68155/8X824 responds by reading the interrupt level on A1 – A3 to determine what level is being acknowledged. If a local interrupt is not pending on the level acknowledged, and that bus level is not masked, the SCB68155/8X824 will assert bus interrupt acknowledge (BIACKN). If that bus level is masked, the SCB68155/8X824 will not respond to the interrupt acknowledge by the local master.

Part of the interrupt acknowledge sequence for a bus interrupt consists of acquiring a vector (status/ID byte) from the system bus.

Table 1. SCB68155/8X824 Interrupt Level Encoding

INTERRUPT REQUEST LEVEL	INTERRUPT PRIORITY LEVEL OUTPUTS		
	IPL2N	IPL1N	IPL0N
NMIN, IRQ7N	0	0	0
LRQ6N, IRQ6N	0	0	1
LRQ5N, IRQ5N	0	1	0
LRQ4N, IRQ4N	0	1	1
LRQ3N, IRQ3N	1	0	0
LRQ2N, IRQ2N	1	0	1
LRQ1N, IRQ1N	1	1	0
None	1	1	1

# Interrupt Handler

# SCB68155

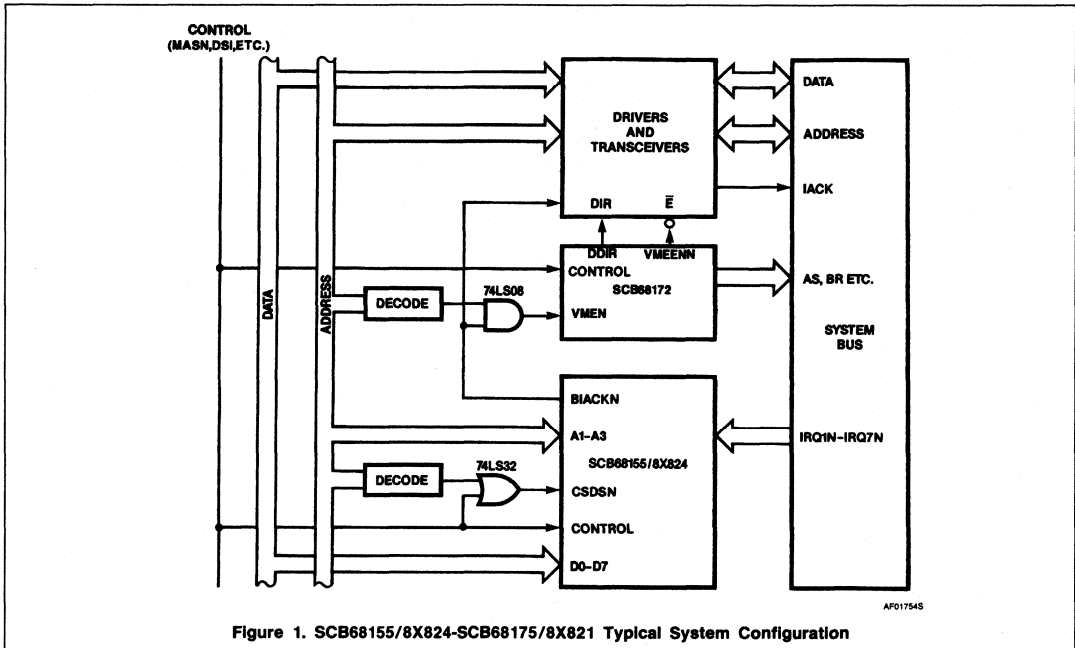

Figure 1. SCB68155/8X824-SCB68175/8X821 Typical System Configuration

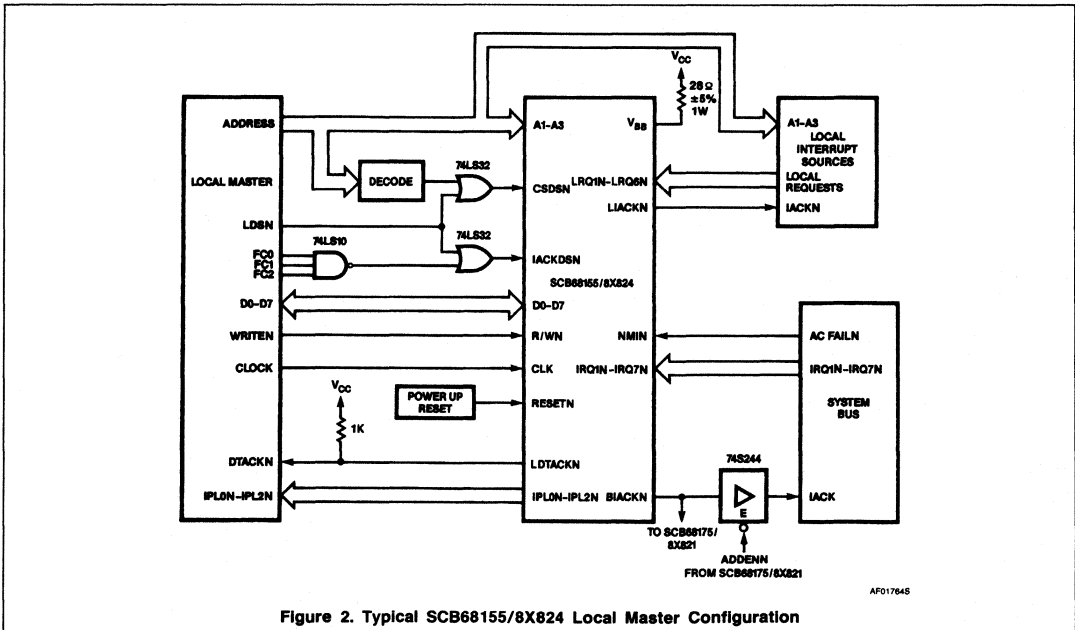

Figure 2. Typical SCB68155/8X824 Local Master Configuration

---

## Interrupt Handler

## SCB68155

---

The bus signals required to acquire this vector are available with a bus controller. The Signetics SCB68172 bus controller can be used by the SCB68155/8X824 to acquire the vector (status/ID byte), thereby eliminating the need for the SCB68155/8X824 to duplicate this bus control function. Because most interrupts are serviced by boards that already have the SCB68172, a one-chip addition of

the SCB68155/8X824 gives that board complete interrupt handling capability.

Since the SCB68155/8X824 is an asynchronous device, it is possible for a local interrupt request to be asserted during acknowledgement of a bus interrupt on the same level. The SCB68155/8X824 passes all local interrupt requests through transparent latches which close during each interrupt acknowl-

edge cycle. All possibility of contention is therefore eliminated.

### **Reset**

When RESETN is asserted, the SCB68155/8X824 drives LDTACKN, LIACKN, BIAACKN and IPL0N - IPL2N all high. The D0 - D7 I/O pins go to 3-State and all internal registers are cleared.

---

**2**

---

## Interrupt Handler

SCB68155

ABSOLUTE MAXIMUM RATINGS<sup>1</sup>

SYMBOL	PARAMETER	RATING	UNIT
T <sub>A</sub>	Operating ambient temperature <sup>2</sup> range	0 to +70	°C
T <sub>STG</sub>	Storage temperature range	-65 to +150	°C
V <sub>CC</sub>	Supply voltage <sup>3</sup> range	-0.5 to +7.0	V
V <sub>IN</sub>	Input voltage <sup>3</sup> range	-0.5 to +5.5	V
V <sub>OUT</sub>	Voltage applied to output in off-state <sup>3</sup>	-0.5 to +5.5	V

DC ELECTRICAL CHARACTERISTICS T<sub>A</sub> = 0°C to +70°C, V<sub>CC</sub> = 5V ± 5%<sup>4, 5, 6</sup>

SYMBOL	PARAMETER	TEST CONDITIONS	LIMITS		UNIT
			Min	Max	
V <sub>CC</sub>	Supply voltage		4.75	5.25	V
V <sub>BB</sub>	Supply voltage		1.35	1.65	V
I <sub>CC</sub>	V <sub>CC</sub> supply current	V <sub>CC</sub> = 5.25V		65	mA
I <sub>BB</sub>	V <sub>BB</sub> supply current	V <sub>BB</sub> = 1.65V		190	mA
I <sub>IL</sub>	Input low current	V <sub>CC</sub> = 5.25V, V <sub>BB</sub> = 1.65V, V <sub>IL</sub> = 0.4V		-20	μA
I <sub>IH</sub>	Input high current	V <sub>CC</sub> = 5.25V, V <sub>BB</sub> = 1.65V, V <sub>IH</sub> = 2.7V		20	μA
I <sub>OS</sub>	Short circuit output current except LDTACKN	V <sub>CC</sub> = 5.25V, V <sub>OUT</sub> = 0V <sup>6</sup>	-15	-100	mA
V <sub>OL</sub>	Output low voltage	V <sub>CC</sub> = 4.75V, V <sub>BB</sub> = 1.35V, I <sub>OL</sub> = 8mA		0.6	V
V <sub>OH</sub>	Output high voltage except LDTACKN	V <sub>CC</sub> = 4.75V, V <sub>BB</sub> = 1.35V, I <sub>OH</sub> = -3mA	2.5		V
I <sub>I</sub>	Input leakage current	V <sub>CC</sub> = 5.25V, V <sub>IN</sub> = 5.25V		100	μA
I <sub>CEX</sub>	Open collector leakage current LDTACKN	V <sub>CC</sub> = 4.75V, V <sub>OUT</sub> = 4.25V		100	μA
V <sub>IC</sub>	Input clamp voltage	V <sub>CC</sub> = 4.75V, I <sub>IN</sub> = -10mA	-1.5		V
V <sub>IL</sub>	Input low voltage			0.8	V
V <sub>IH</sub>	Input high voltage		2		V

## NOTES:

- Stresses above those listed under Absolute Maximum Ratings may cause permanent damage to the device. This is stress rating only and functional operation of the device at these or at any other condition above those indicated in the operation section of this specification is not implied.
- For operating at elevated temperatures, the device must be derated based on +150°C maximum junction temperature and thermal resistance of 60°C/W junction to ambient for ceramic package (116°C/W for plastic package).
- This product includes circuitry specifically designed for the protection of its internal devices from damaging effects of excessive static charge. Nonetheless, it is suggested that conventional precautions be taken to avoid applying any voltages larger than the rated maxima.
- Parameters are valid over specified temperature range.
- All voltage measurements are referenced to ground (GND). For testing, all inputs swing between 0.4V and 2.4V with a transition time of 3ns maximum and output voltages are checked at 0.8V and 2V.
- At any time, no more than one output should be connected to ground.
- t<sub>RST</sub> is always greater than or equal to t<sub>DTH</sub>.
- t<sub>TRST</sub> is always greater than or equal to t<sub>DAH</sub>.

## Interrupt Handler

SCB68155

AC ELECTRICAL CHARACTERISTICS  $T_A = 0^\circ\text{C}$  to  $+70^\circ\text{C}$ ,  $V_{CC} = 5\text{V} \pm 5\%^{4, 5}$ 

SYMBOL	PARAMETER	TENTATIVE LIMITS		UNIT
		Min	Max	
<b>Register read (see Figure 3)</b>				
$t_{RWS}$	R/WN to CSDSN low setup time	10		ns
$t_{IAKS}$	IACKDSN high to CSDSN low setup time	10		ns
$t_{ADRS}$	A1 – A3 valid to CSDSN low setup time	30		ns
$t_{DTV}$	CSDSN low to D0 – D7 setup time		89	ns
$t_{ACCR}$	CSDSN low to LDTACKN low read access time		$2t_{CKPD} + 116^8$	ns
$t_{RWH}$	CSDSN high to R/WN high hold time	0		ns
$t_{ADRH}$	CSDSN high to A1 – A3 valid hold time	0		ns
$t_{DTH}$	CSDSN high to D0 – D7 valid hold time	0	79	ns
$t_{TST}^7$	CSDSN high to D0 – D7 3-State	0	80	ns
$t_{ACK}$	CSDSN high to LDTACKN high time	0	66	ns
$t_{CSH}$	CSDSN high time	10		ns
$t_{DTCS}$	LDTACKN low to CSDSN high	0		ns
<b>Register write (see Figure 4)</b>				
$t_{RWS2}$	R/WN low to CSDSN low setup time	10		ns
$t_{IAKS}$	IACKDSN high to CSDSN low setup time	10		ns
$t_{ADRS}$	A1 – A3 valid to CSDSN low setup time	30		ns
$t_{DS}$	D0 – D7 valid to CSDSN low setup time	0		ns
$t_{ACCW}$	CSDSN low to LDTACKN low write access time		$2t_{CKPD} + 116^8$	ns
$t_{RWH2}$	CSDSN high to R/WN low hold time	0		ns
$t_{ADRH}$	CSDSN high to A1 – A3 valid hold time	0		ns
$t_{DH}$	CSDSN high to D0 – D7 valid hold time	0		ns
$t_{ACK}$	CSDSN high to LDTACKN high time	0	66	ns
$t_{CSH}$	CSDSN high time	100		ns
$t_{DTCS}$	LDTACKN low to CSDSN high time	0		ns
<b>Vector mode (see Figure 5)</b>				
$t_{CSS}$	CSDSN high to IACKDSN low setup time	10		ns
$t_{PDL}$	IACKDSN low to LIACKN low propagation time	$t_{CKPD}$	$2t_{CKPD} + 68$	ns
$t_{DAV}$	IACKDSN low to D0 – D7 vector valid		103	ns
$t_{ACCV}$	IACKDSN low to LDTACKN low (vector access time)	$t_{CKPD}$	$t_{CKPD} + 116^8$	ns
$t_{IKH}$	IACKDSN high time	100		ns
$t_{DAH}$	IACKDSN high to D0 – D7 valid hold time	0	111	ns
$t_{TRST}^8$	IACKDSN high to D0 – D7 3-State	0	115	ns
$t_{IKDT}$	IACKDSN high to LDTACKN high	0	81	ns
$t_{PDH}$	IACKDSN high to LIACKN high propagation delay	0	42	ns
$t_{DTIK}$	LDTACKN low to IACKDSN high time	0		ns
$t_{ADRS}$	A1 – A3 valid to IACKDSN low setup time	0		ns
$t_{ADH}$	IACKDSN high to A1 – A3 valid hold time	0		ns
<b>Device supplies the vector mode (see Figure 6)</b>				
$t_{CSS}$	CSDSN high to IACKDSN low setup time	10		ns

## Interrupt Handler

SCB68155

## AC ELECTRICAL CHARACTERISTICS (Continued)

SYMBOL	PARAMETER	TENTATIVE LIMITS		UNIT
		Min	Max	
$t_{PDL}$	IACKDSN low to LIACKN low propagation time delay	$t_{CKPD}$	$2t_{CKPD} + 68$	ns
$t_{KH}$	IACKDSN high time	100		ns
$t_{PDH}$	IACKDSN high to LIACKN high propagation delay	0	42	ns
$t_{ADS}$	A1 - A3 valid to IACKDSN low setup time	0		ns
$t_{ADH}$	IACKDSN high to A1 - A3 valid hold time	0		ns
<b>Bus interrupt acknowledge (see Figure 7)</b>				
$t_{CSS}$	CSDSN high IACKDSN low setup time	10		ns
$t_{PDL2}$	IACKDSN low to BLACK low propagation delay	$t_{CKPD}$	$2t_{CKPD} + 68$	ns
$t_{KH}$	IACKDSN high time	100		ns
$t_{PDH2}$	IACKDSN high to BLACK high propagation delay	0	50	ns
$t_{ADS}$	A1 - A3 valid to IACKDSN low setup time	0		ns
$t_{ADH}$	IACKDSN high to A1 - A3 hold time	0		ns
<b>Reset timing (see Figure 8)</b>				
$t_{RST}$	RESET low time	120		ns
<b>Clock timing (see Figure 9)</b>				
$t_{CKPD}$	Clock period	100		ns
$t_{CKH}$	Clock high	50		ns





Interrupt Handler

SCB68155

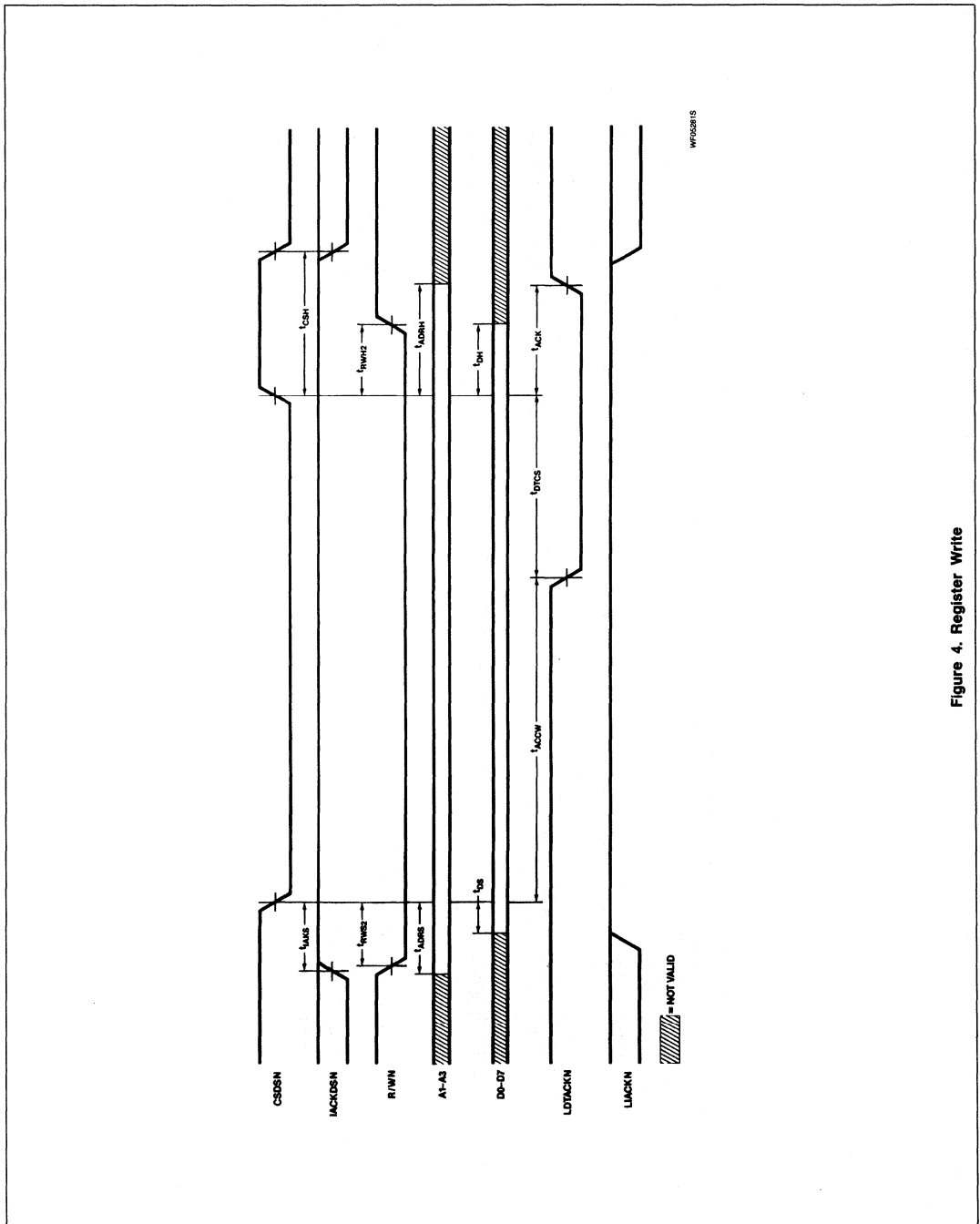

Figure 4. Register Write

# Interrupt Handler

SCB68155

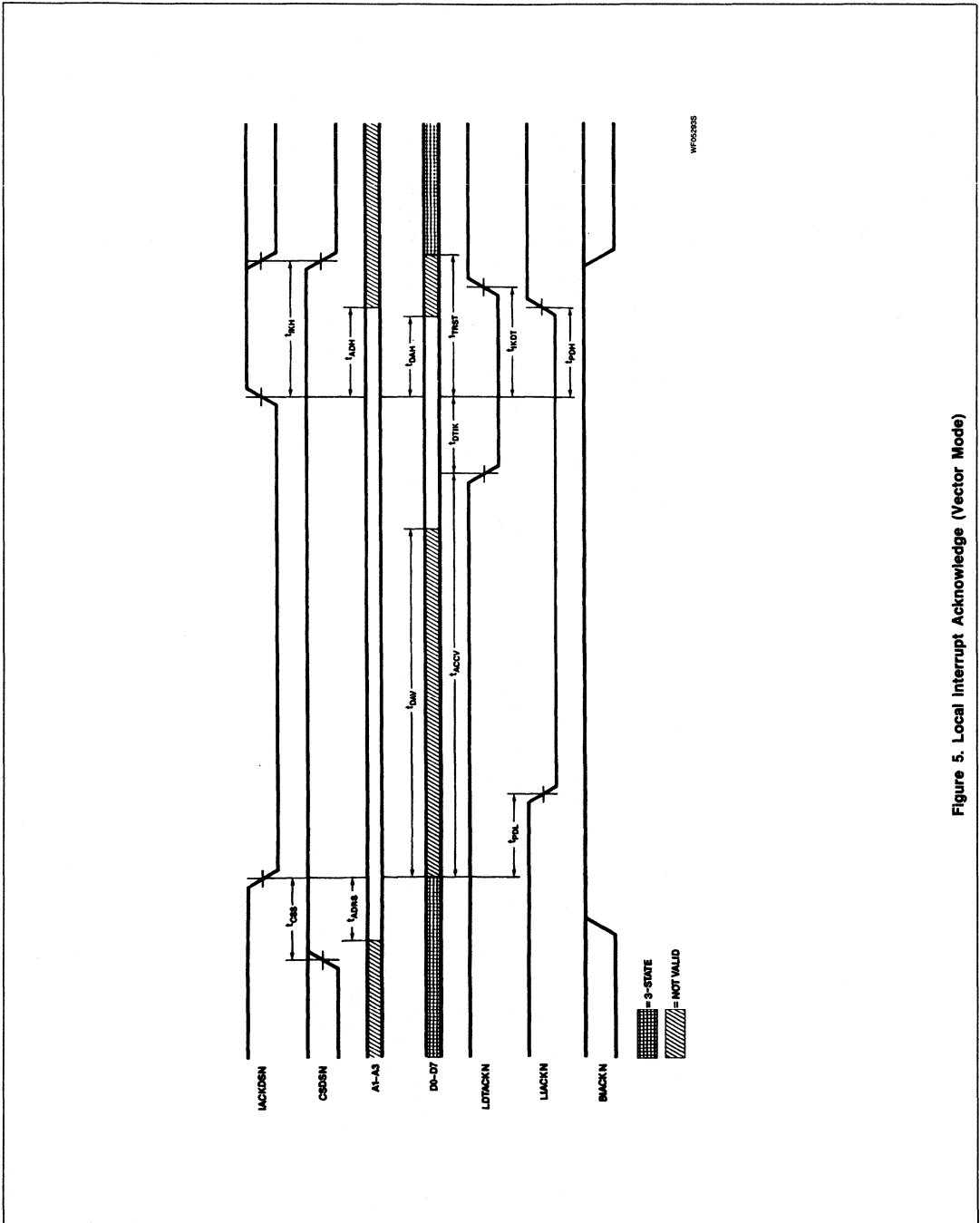

Figure 5. Local Interrupt Acknowledge (Vector Mode)

# Interrupt Handler

SCB68155

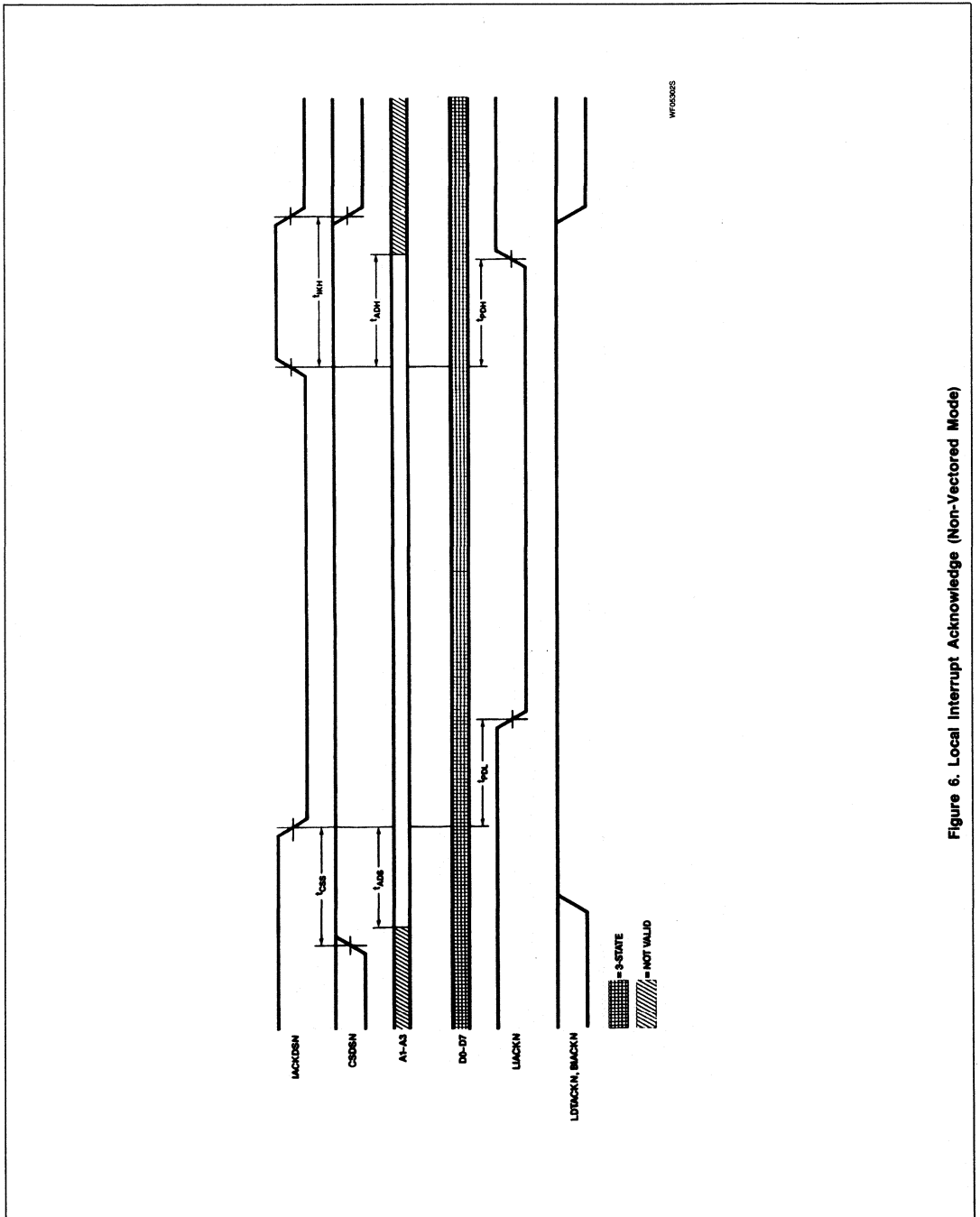

Figure 6. Local Interrupt Acknowledge (Non-Vectored Mode)

# Interrupt Handler

SCB68155

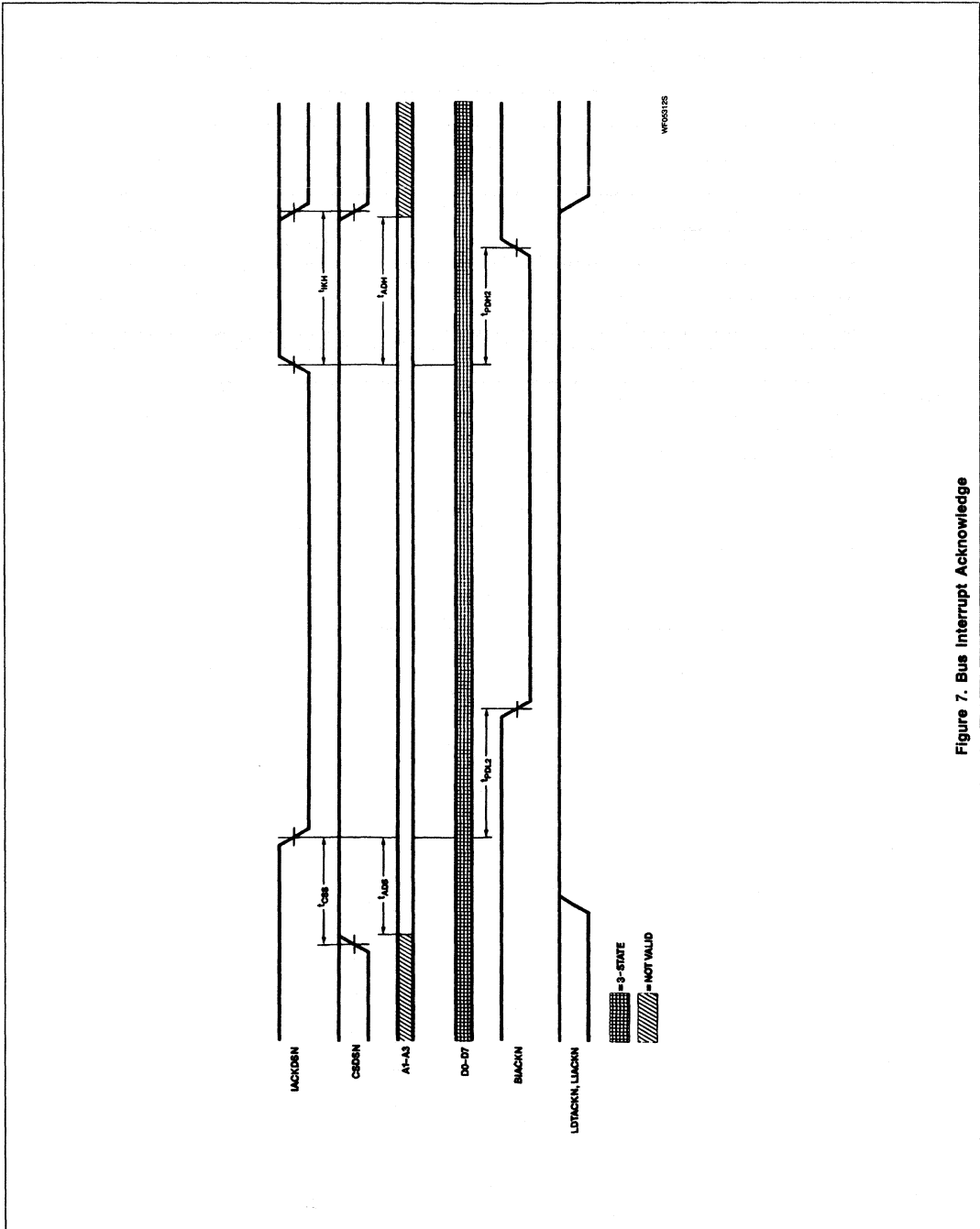
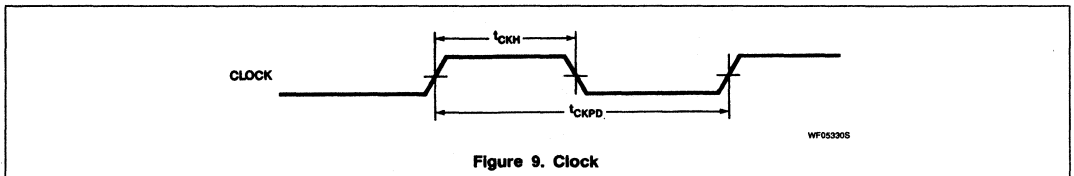
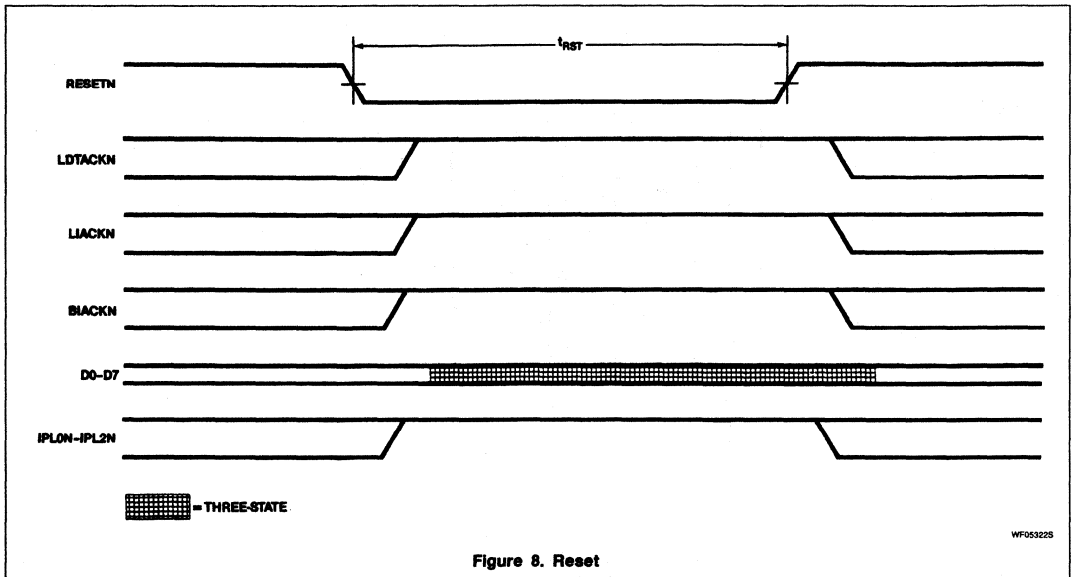

Figure 7. Bus Interrupt Acknowledge

# Interrupt Handler

# SCB68155



# SCB68171

## Very Little Serial Interface Chip (VLSIC)

Preliminary Specification

### Microprocessor Products

#### DESCRIPTION

The Signetics Very Little Serial Interface Chip (VLSIC) is a bipolar interface device which connects one or more VMSbus controllers to the VMSbus itself. It provides bus driving and receiving in addition to latching data in both the transmit and receive directions.

SERCLK on the VMSbus has a waveform as shown in Figure 1, with four edges per cycle which are designated C1, S1, C2, S2. SYSCLK is used to discriminate (differentiate) the phases of SERCLK. The SYSCLK input should have a nominal 50% duty cycle and a cycle time which is 2/11 that of SERCLK, but SYSCLK and SERCLK need not be synchronous or have any fixed phase relationship. The 16MHz SYSCLK on the VMEbus meets these requirements for a back plane 2.9MHz SERCLK.

The VLSIC samples the XDATAN input on the SERCLK edge designated C1. XDATAN is clocked directly to SERDATN. The VLSIC then clocks the low-active OR (positive logic AND) of SERDATN and SERDATIN to RDATAN on the S1 edge. If XDATAN was high at C1, the VLSIC then samples the XSTARTN input on the C2 edge, and if it is low, the VLSIC makes SERDATN low, thus making a VMSbus start bit. If XDATAN was high at S1, then on the S2 edge it clocks the low active OR of SERDATN and SERDATIN to RSTARTN. If SERDATN was low at S1, it keeps (or makes) RSTARTN high at S2.

CHIPCLK is driven high from the C1 edge of SERCLK, and driven low from the C2 edge. Thus RDATAN and RSTARTN setup to CHIPCLK edges by approximately the low time of SERCLK. The VMSbus controller(s) must meet the specified setup and hold times to C1 for XDATAN and to C2 for XSTARTN.

#### FEATURES

- 70mA open-collector drive for SERDATN
- Low capacitive loading
- Discriminates SERCLK into single-phase chip clock output
- Separates data and start bits for both receive and transmit
- Provides single bus load for multiple VMSbus controllers
- Simplifies controller design and allows use of slower technology
- VMEbus receiver for SYSCLK
- VMEbus driver/receiver for SYSRESÉTN
- 16-pin DIP

#### ORDERING INFORMATION

DESCRIPTION	PARAMETER	ORDERING CODE
16-Pin Plastic DIP	V <sub>CC</sub> 5V ± 5%, T <sub>A</sub> = 0 to 70°C	SCB68171C3N16

#### PIN CONFIGURATION

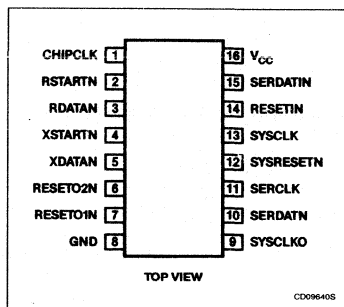

## Very Little Serial Interface Chip (VLSIC)

SCB68171

**DESCRIPTION (Continued)**

A VMSbus controller is required to "jam" the bus by sending a string of "ones" (low) on SERDATN when a start bit is sensed while the controller is sending or tracking a frame. The first one bit should directly follow the misplaced start bit. Since the minimum S2-to-C1 time of SERCLK (25ns) is less than the sum of the maximum S2-to-RSTART-low time plus the minimum setup of XDATAN to C1, a controller cannot do this using XDATAN in the normal fashion.

The following feature is provided to solve this problem. The condition XDATAN low,

XSTARTN low, and CHIPCLK high directly sets the flipflop controlling SERDATN, and makes SERDATN low. (Note that a VMSbus controller would never assert both XDATAN and XSTARTN low in normal operation.) The assertion of both XDATAN and XSTARTN must occur soon enough to satisfy the SERDATN to S1 setup requirements of all the modules on the VMSbus.

The VLSIC is primarily intended for use in the P1 region of a VMEbus card. Space and functionality is at a premium in this area. Accordingly, the VLSIC includes an auton-

omous function of driving and receiving SYSRESETN on the VMEbus. A low on the RESETN input makes the VLSIC drive the SYSRESETN pin low. SYSRESETN is also received and driven onto two open-collector outputs RESETO1N and RESETO2N. RESETO1N has a high drive capability and is suitable for connection to the RESETN pin of a 680x0 processor, while RESETO2N has lower drive and capacitance and can be connected to the processor's HALTN pin. This function has no connection to the rest of the VLSIC, and could thus be used for some other purpose.

**PIN DESCRIPTION**

MNEMONIC	PIN NO.	TYPE	NAME AND FUNCTION
SERCLK	11	I	<b>Direct connect to VMSbus clock:</b> Clocks SERDATN to RDATAN, RSTARTN. Clocks XDATAN, XSTARTN to SERDATN. Used to generate single-phase CHIPCLK.
SYSCLK	13	I	<b>Direct connect to VMEbus clock or other signal meeting the specified frequency relationship to SERCLK:</b> Used to discriminate the phases of SERCLK.
SYSCLKO	9	O	<b>Repeater of SYSCLK for onboard use.</b>
SERDATN	10	I/O	<b>Direct connect to VMSbus data in bipolar open-collector links:</b> Provides data output function for other types of links (e.g. optical). Requires pull-up resistor in either case.
SERDATIN	15	I	<b>Tied to high logic level in bipolar open-collector links:</b> Provides data input function for other types of links (e.g. optical).
CHIPCLK	1	O	<b>Single phase clock for VMSbus controllers.</b>
RDATAN	3	O	<b>Conveys one/zero bits to VMSbus controller(s).</b>
RSTARTN	2	O	<b>Conveys start bits to VMSbus controller(s).</b>
XDATAN	5	I	<b>Input from VMSbus controller(s):</b> In normal operation, a low on this line indicates a "one" bit should be sent. Simultaneous assertion of XDATAN and XSTARTN low, while CHIPCLK is high, drives SERDATN low directly in a "jam" condition.
XSTARTN	4	I	<b>Input from VMSbus controller(s):</b> In normal operation, a low on this line indicates a "start" bit should be sent. Simultaneous assertion of XDATAN and XSTARTN low, while CHIPCLK is high, drives SERDATN low directly in a "jam" condition.
RESETN	14	I	<b>Input from onboard logic:</b> Low state forces SYSRESETN low.
SYSRESETN	12	I/O	<b>Direct connect to VMEbus system reset:</b> Open-collector output from RESETN, received to drive RESETO1N and RESETO2N. Does not affect other VLSIC logic.
RESETO1N	7	O	<b>High-drive open-collector output from SYSRESETN.</b>
RESETO2N	6	O	<b>Low-drive open-collector output from SYSRESETN.</b>
V <sub>CC</sub>	16		<b>+5 Volts</b>
GND	8		<b>Ground</b>

**VMSBUS CONTROLLER DESIGN**

Controllers using VLSIC should signal as follows on XDATAN and XSTARTN.

1. Controllers should present the next bit on XDATAN in response to the falling edge of CHIPCLK, and on XSTARTN in response to the rising edge of CHIPCLK. For a 2.9MHz SERCLK, they have at least 90nsec to do so, and approximately 120nsec from RDATAN valid.
2. Controllers may release XDATAN to high in response to the rising edge of

CHIPCLK, and may release XSTARTN to high in response to the falling edge. Since these are typically open-collector outputs of the controllers, there may be a timing advantage to do so.

3. A controller should present XDATAN and XSTARTN low in a "jam" situation, in a combinatorial fashion from RSTARTN. Thereafter the controller can release XSTARTN from the lowgoing edge of CHIPCLK, and may either signal 511 or 512 one bits in the usual fashion (1 and 2 above), or may just keep XDATAN low.

4. If two VMSbus controllers connected to the same VLSIC become "locally desynchronized", it is possible that one will present XDATAN low and the other XSTARTN low for the same bit cell. If this occurs, XDATAN predominates and SERDATN is driven low for a "one" bit. Thus a possible transient combination of XDATAN and XSTARTN low and CHIPCLK high actually has no effect. The controller presenting XSTARTN thereafter receives RDATAN low, and continues to try to send the start bit.



# Very Little Serial Interface Chip (VLSIC)

SCB68171

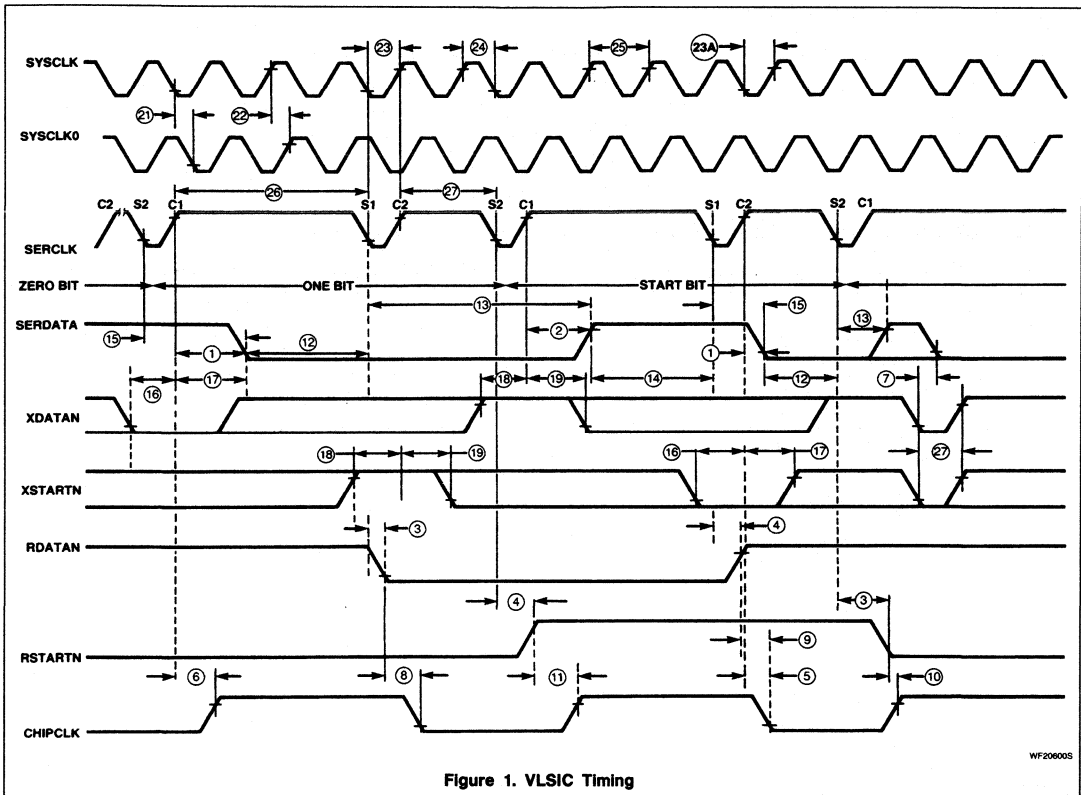

Figure 1. VLSIC Timing

WF206008

## Very Little Serial Interface Chip (VLSIC)

SCB68171

ABSOLUTE MAXIMUM RATINGS<sup>1</sup>

SYMBOL	PARAMETER	RATING	UNIT
V <sub>S</sub>	Supply voltage range	-0.5 to +7	V
V <sub>IN</sub>	Input voltage range	-0.5 to +5.5	V
T <sub>A</sub>	Operating temperature range <sup>2</sup>	0 to +70	°C
T <sub>STG</sub>	Storage temperature range	-65 to +150	°C

DC ELECTRICAL CHARACTERISTICS V<sub>CC</sub> = 5V ± 5%, T<sub>A</sub> = 0°C to +70°C, R<sub>L</sub> = 90, C<sub>L</sub> = 15pF<sup>3, 4</sup>

SYMBOL	PARAMETER	TEST CONDITIONS	LIMITS			UNIT
			Min	Typ	Max	
I <sub>IL</sub> I <sub>IH</sub>	Low-level input current High-level input current	V <sub>IN</sub> = 0.4V V <sub>IN</sub> = 2.7V			-0.4 20	mA μA
V <sub>IL</sub> V <sub>IH</sub>	Low-level input voltage High-level input voltage		2		0.8	V V
V <sub>TH+</sub> - V <sub>TH-</sub>	Hysteresis — All inputs			300		mV
V <sub>OL</sub> V <sub>OH</sub>	Low level output voltage CHIPCLK, RDATA, RSTARTN, RESETO2N SYSCLKO SERDATN, RESETO1N, SYSRESETN High level output voltage CHIPCLK, RDATA, RSTARTN, SYSCLKO	I <sub>OL</sub> = 8mA I <sub>OL</sub> = 24mA I <sub>OL</sub> = 70mA I <sub>OH</sub> = -3mA			0.5 0.5 0.5	V V V
I <sub>OH</sub>	Output leakage current SERDATN, RESETO1N, SYSRESETN RESETO2N		2.7			V
I <sub>CC</sub>	V <sub>CC</sub> supply current	V <sub>OH</sub> = 5.5V V <sub>CC</sub> = Max			100 60	μA mA
C <sub>i</sub> C <sub>IO</sub>	Input capacitance SERCLK, SYSCLK I/O capacitance SERDATN			5 10		pF pF

## NOTES:

- Stresses above those listed under Absolute Maximum Ratings may cause permanent damage to the device. This is stress rating only and functional operation of the device at these or at any other conditions other than those indicated in the Electrical Characteristics section of this data sheet is not implied.
- For operating at elevated temperatures, the device must be derated based on +150°C maximum junction temperature.
- Parameters are valid over specified temperature range.
- All voltage measurements are referenced to ground (GND). All time measurements are referenced at input voltages of 0.8V and 2V as appropriate.

# Very Little Serial Interface Chip (VLSIC)

SCB68171

**2**

## AC ELECTRICAL CHARACTERISTICS $V_{CC} = 5V \pm 5\%$ , $T_A = 0^\circ C$ to $+70^\circ C$ , $R_L = 90$ , $C_L = 50pF^{3, 4}$ (except as noted)

NO.	CHARACTERISTIC	TENTATIVE LIMITS		UNIT
		Min	Max	
1	Prop, C1 or C2 to SERDATN low	10	20	ns
2	Prop, C1 to SERDATN released	10	25	ns
3	Prop, S1 (S2) to RDATAN (RSTARTN) low		20	ns
4	Prop, S1 (S2) to RDATAN (RSTARTN) high		20	ns
5	Prop, C2 to CHIPCLK low		15	ns
6	Prop, C1 to CHIPCLK high		12	ns
7	Prop, XDATAN low and XSTARTN low (with CHIPCLK high) to SERDATN low <sup>5</sup>		25	ns
8	RDATAN low to CHIPCLK low	$t_{CL-10}$		ns
9	RDATAN high to CHIPCLK low	$t_{CL-12}$		ns
10	RSTARTN low to CHIPCLK high	$t_{CL-10}$		ns
11	RSTARTN high to CHIPCLK high	$t_{CL-12}$		ns
12	Setup, SERDATN and/or SERDATIN low to S1 or S2	8		ns
13	Hold, SERDATN and/or SERDATIN low after S1 or S2	2		ns
14	Setup, SERDATN and SERDATIN high to S1 or S2	6		ns
15	Hold, SERDATN and SERDATIN high after S1 or S2	2		ns
16	Setup, XDATAN low to C1, XSTARTN low to C2	7		ns
17	Hold, XDATAN low after C1, XSTARTN low after C2	0		ns
18	Setup, XDATAN high to C1, XSTARTN high to C2	7		ns
19	Hold, XDATAN high after C1, XSTARTN high after C2	0		ns
20	Pulse Width, XDATAN and XSTARTN low with CHIPCLK high	10		ns
21	Prop, SYSCLK low to SYSCLKO low	8	15	ns
22	Prop, SYSCLK high to SYSCLKO high	5	12	ns
23	Pulse width, SERCLK low ( $t_{CL}$ )	15		ns
23A	Pulse width, SYSCLK low ( $t_{SYCL}$ )	10		ns
24	Pulse width, SYSCLK high ( $t_{SYCH}$ )	10		ns
25	Cycle time, SYSCLK ( $t_{SYCY}$ )	62		ns
25A	Cycle time, SERCLK	(general case) 5.49( $t_{SYSY}$ )	551( $t_{SYSY}$ )	ns
26	Pulse width, SERCLK high, C1 to S1	( $t_{SYCY} = 62.5$ ) 174.25 (general case) 2.5 $t_{SYCY} + 18$		ns ns
27	Pulse width, SERCLK high, C2 to S2	( $t_{SYCY} = 62.5$ ) (general case)	120 2( $t_{SYCY}$ ) - 5	ns ns

## TEST CONDITIONS

TEST CONDITIONS:

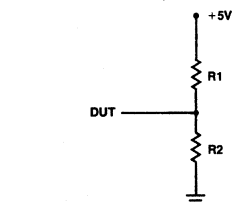

SIGNALS	R1	R2
CHIPCLK, RSTARTN, RDATAN	453Ω	267Ω
SYSCLKO	162Ω	124Ω

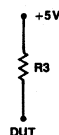

SIGNALS	R3
SYSRESETN, RESET01N, SERDATN	69.8Ω
RESET02N	562Ω

TC211905

# SCB68172

## VMEbus Controller (BUSCON)

Preliminary Specification

### Microprocessor Products

#### DESCRIPTION

The Signetics SCB68172 VMEbus Controller (BUSCON) is an interface device for the VMEbus. It can be used in three different configurations: master-only, slave-only, and master/slave. The SCB68172 can be used with a processor-type interface or with a DMA controller-type interface. In all configurations, it handles the VMEbus signaling protocol in compliance with revisions B and C of the VMEbus Specification.

#### CONFIGURATION/VERSION

Applications of the BUSCON are identified as follows (see Figures 1 through 4):

VERSION	APPLICATION
PMS	Processor-type master/slave
DMAC	DMA controller-type master/slave
MS	Either PMS or (DMAC)
M	Master-only
S	Slave-only

All of these applications are handled by the SCB68172, with unused pins tied to stated logic levels in some of the applications.

Figure 5 shows a functional model of the SCB68172 logic. The ASN, MASN, LBRN, BGINN, and RELSE inputs are internally synchronized to CLK before being presented to the state machine which determines the major functions of the device. The SLVN, ONBD, and VMEN signals are used directly in the state machine, although they are highly qualified to prevent metastable conditions on the state machine outputs. The BRN, BBSYN and LBGN signals are direct state machine outputs, while ASN, MASTENN, VMEENN, SLVSELN, and BGOUTN are derived from the state machine outputs plus some combinatorial qualification.

The DSI, R/WN, DTACKN, BERRN, LDTACKN, and LBERRN inputs function largely as direct combinatorial inputs. The DDIR, DTACKN, BERRN, LDTACKN, LBERRN, and (when applicable) MASN outputs are largely derived directly from these direct inputs, with some qualification from the state machine outputs. The DENN and DSENN outputs have complex multi-case logic which uses both the direct inputs and the state machine outputs.

#### FEATURES

- Master, slave, or master/slave (dual ported) applications
- Helps assure VMEbus compatibility
- Allows for address decoding time
- Processor or DMA controller interface for master/requester
- Master/requester logic allows release on request (ROR) or release when done (RWD) operation, early or intercycle release
- Supports and exploits address lookahead

#### PIN CONFIGURATIONS

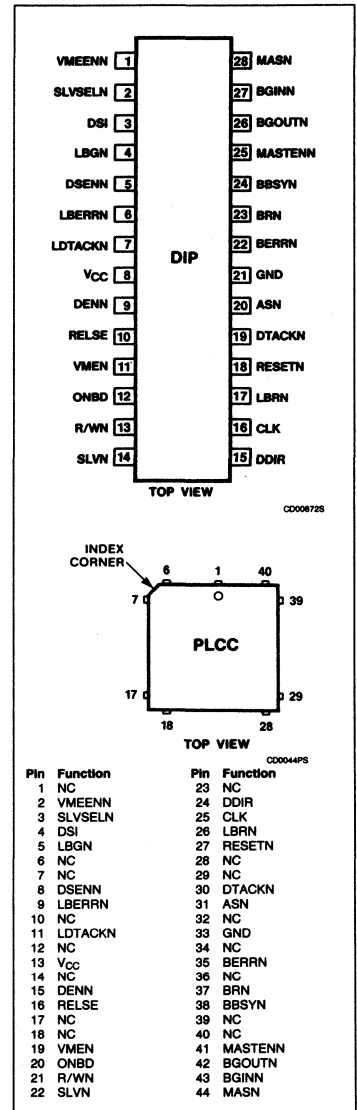

## VMEbus Controller (BUSCON)

SCB68172

2

## ORDERING INFORMATION

PACKAGES	$V_{CC} = 5V \pm 5\%$ , $T_A = 0^\circ C$ to $70^\circ C$
CERDIP	SCB68172C2F28
Plastic DIP	SCB68172C2N28
Plastic LCC	SCB68172C2A44

## PIN DESCRIPTION

MNEMONIC	PIN NO.		TYPE	CONFIG	NAME AND FUNCTION
	DIP	PLCC			
CLK	16	25	I	All	<b>Clock:</b> User-supplied clock signal.
SLVN	14	22	I	S,MS	<b>Slave:</b> Active-low decode of the VMEbus address and address modifier lines indicating that the current cycle is for this board. SLVN should not be qualified with ASN nor VMEENN. It is first sampled on the rising clock edge after the rising edge on which ASN is first detected. It must remain valid until after the next low-going edge on DTACKN or BERRN. In a master-only application, SLVN should be pulled up to $V_{CC}$ .
ASN	20	31	I/O I	M,MS S	<b>Address Strobe:</b> Direct connect to VMEbus ASN.
VMEN	11	19	I	M,MS	<b>VME Decode:</b> Active-low decode of the master's address lines, indicating that the master's current cycle is for a slave on the VMEbus. VMEN should not be qualified with MASN nor MASTENN. It is first sampled on the rising clock edge after the one on which MASN is first detected. Thereafter, it must remain valid until MASN goes false (high). In a slave-only configuration, VMEN should be pulled up to $V_{CC}$ .
LBRN	17	26	I	M,MS	<b>Local Bus Request:</b> Connected to the low-active bus request output of a DMA controller. Typically tied to a high logic level in processor-type interfaces.
ONBD	12	20	I	MS	<b>Onboard:</b> Active-high decode of the master's address lines, indicating that the master's current cycle is for an onboard slave that is dual-ported with the VMEbus. ONBD should not be qualified with MASN or MASTENN. It is first sampled on the rising clock edge after the one on which MASN is first detected. Thereafter, it must remain valid until after MASN goes false (high). In a master-only or slave-only application, ONBD should be grounded. If a master/slave configuration does not contain "local slaves" as shown in Figure 3, VMEN and ONBD should both be connected to an active-low "VME decode". A cycle between the onboard master and a local slave (VMEN high, ONBD low) is ignored by BUSCON, and can proceed concurrently with a cycle between another VMEbus master and an onboard dual-ported slave.
MASN	28	44	I I/O	M,PMS DMAC	<b>Master's Address Strobe:</b> RMW and Sequential VMEbus master cycles are accomplished by holding MASN low across several data strobes. If LBGH is high at the end of the RESETN low time, the state of ASN is driven onto MASN whenever BUSCON does not have control of the VMEbus. In a slave-only application, MASN should be pulled up to $V_{CC}$ .
MASTENN	25	41	O	MS	<b>Master Enable:</b> In a master/slave application, the low state of this signal enables the master onto the shared bus and enables shared-bus responses back to the master. MASTENN also provides the direction control for the VMEbus address transceivers.
VMEENN	1	2	O	M,MS	<b>VME Enable:</b> Active-low enable for the VMEbus address drivers (master-only) or transceivers (master/slave).
SLVSELN	2	3	O	S,MS	<b>Slave Select:</b> Active-low select for the onboard slave resources (the shared/dual ported slaves in a master/slave application). Derived from MASN and ONBD, or from ASN and SLVN. If necessary, MASTENN and VMEENN are cycled to provide address setup time before SLVSELN is asserted.
BRN	23	37	O	M,MS	<b>Bus Request:</b> Active-low, open collector VMEbus request. Direct connect to the selected level among VMEbus BR0* - BR3*.
BGINN	27	43	I	M,MS	<b>Bus Grant In:</b> Direct connect to the selected level among VMEbus BG0IN* - BG3IN*.

## VMEbus Controller (BUSCON)

SCB68172

## PIN DESCRIPTION (Continued)

MNEMONIC	PIN NO.		TYPE	CONFIG	NAME AND FUNCTION
	DIP	PLCC			
BGOUTN	26	42	O	M,MS	<b>Bus Grant Out:</b> Direct connect to the selected level among VMEbus BG0OUT* - BG3OUT*.
BBSYN	24	38	O	M,MS	<b>Bus Busy:</b> Active-low, open collector direct connect to VMEbus BBSYN*.
LBGN	4	5	I/O	M,MS	<b>Local Bus Grant:</b> Active-low, open collector. Can be connected to the bus grant input of a DMA controller. Asserted when LBRN is low and the BUSCON has control of the VMEbus. Grounded, or driven low during RESET, to prevent the ASN state being driven onto MASN when the BUSCON is not in control of the VMEbus.
RELSE	10	16	I	M,MS	<b>Release:</b> Active-high signal indicating that the onboard logic wants to release control of the VMEbus. In DMA controller applications, the BGACKN output of the DMAC should be connected to (or positive-logic ANDed into) this signal.
DTACKN	19	30	I/O O	M,MS S	<b>Data Transfer Acknowledge:</b> Active-low, open collector. Direct connect to VMEbus DTACK*.
BERRN	22	35	I/O O	M,MS S	<b>Bus Error:</b> Active-low, open collector. Direct connect to VMEbus BERR*.
LDTACKN	7	11	O, I/O I	M, MS S	<b>Local DTACK:</b> Active-low, open collector. Output to onboard master and/or input from onboard slave.
LBERRN	6	9	O, I/O I	M, MS S	<b>Local Bus Error:</b> Onboard active-low, open collector. Output to onboard master and/or input from onboard slave.
DSI	3	4	I	All	<b>Data Strobe:</b> The high-active or of the onboard data strobes, which may be from the onboard master or VMEbus master.
DSENN	5	8	O	M,MS	<b>Data Strobe Enable:</b> Low-active, used to enable the onboard data strobes onto the VMEbus.
R/WN	13	21	I	All	<b>Read/Write:</b> Onboard R/W signal from the onboard master or VMEbus master.
DDIR	15	24	O	All	<b>Data Direction Control:</b> Direction control for VMEbus data transceivers. A high level indicates the "onboard-to-VMEbus" direction.
DENN	9	15	O	All	<b>Data Enable:</b> Low-active enable for VMEbus data transceivers.
RESETN	18	27	I	All	<b>RESET:</b> Low-active reset. Clears BUSCON logic.
V <sub>CC</sub>	8	13	I	All	<b>Power Supply:</b> +5V
GND	21	33	I	All	<b>Ground:</b> 0V reference.

## ADDRESS DECODING

Both the VMEbus and current high-speed processors provide short address-to-strobe setup times, such that with all but the most simple decode schemes, designers must provide for delaying the strobe until decoder outputs have become valid. However, BUSCON operates as a finite-state machine and must synchronize address strobes and other inputs before it can act on them. The BUSCON design allows this synchronization time to be overlapped with address decoding.

In general, most BUSCON inputs do not have critical timing parameters. Exceptions are the three address decode signals. Figure 6 shows a somewhat simplified model of the VMEbus slave selection logic in the SCB68172. The ASN signal is qualified and sampled by flip-flops A and B on each rising edge of CLK. Flip-flop C is set when ASN is high between cycles, and cleared by a falling edge on DTACKN or BERRN.

On the rising edge of CLK after flip-flop B samples ASN low, if C is still set and SLVN is low, flip-flop D is set, indicating slave selection. (In reality, there are more terms in the logic to set D.) Once D is set, it remains set until flip-flop A samples ASN high and a similar circuit (not shown) samples DSI low.

Since SLVN is a direct input to flip-flop D, it must meet a setup time to the clock after ASN is sampled low. Viewed asynchronously, SLVN should be valid slightly less than one clock period after ASN goes low, through shortly after DTACKN goes low.

The onboard logic driven by MASN, VMEN, and ONBD is similar but not as complex. Neither flip-flop C nor a data-strobe-related signal are used, and there are separate flip-flops corresponding to D for each of the VMEN and ONBD signals. VMEN and ONBD should be valid slightly less than one clock period after MASN goes low, through shortly after MASN goes high.

Because ASN and MASN are used directly to clear the corresponding "flip-flop B", their minimum high times are relatively short. However, for consecutive cycles, the inactive time of "flip-flop D" (and signals derived from it) will be at least two clock periods because of the feedback path from "D" to "B".

## VMEbus ARBITRATION

BUSCON begins VMEbus arbitration by driving BRN low if MASN, VMEN and ONBD indicate a VMEbus cycle (or if LBRN goes low) and the BUSCON does not have control of the bus.

After driving BRN, BUSCON waits for the BGINN input which is connected to the selected one among the four VMEbus arbitration levels. (During this time it can of course respond to cycles from other VMEbus masters.) When it receives BGINN low while holding BRN low, it drives BBSYN low and thereafter releases BRN. (If it receives



# VMEbus Controller (BUSCON)

SCB68172

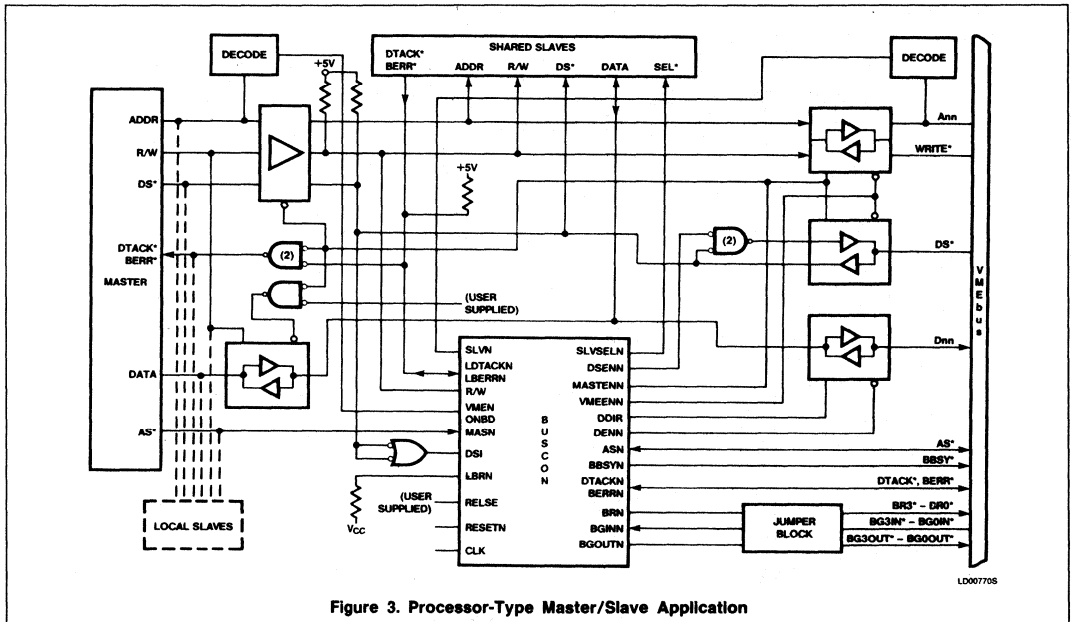

Figure 3. Processor-Type Master/Slave Application

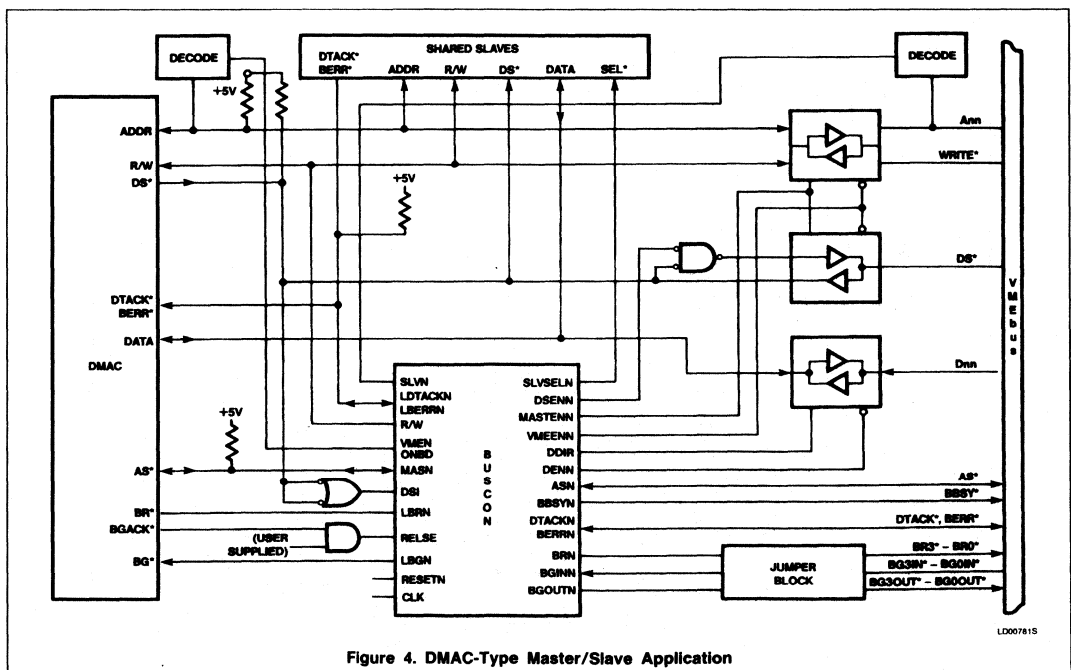
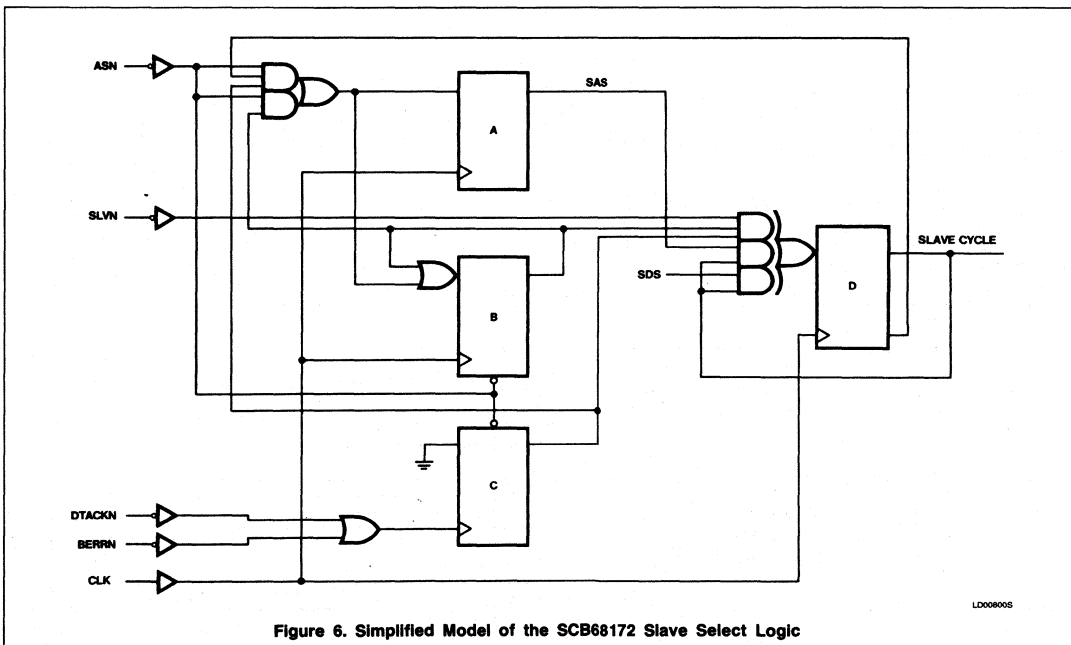
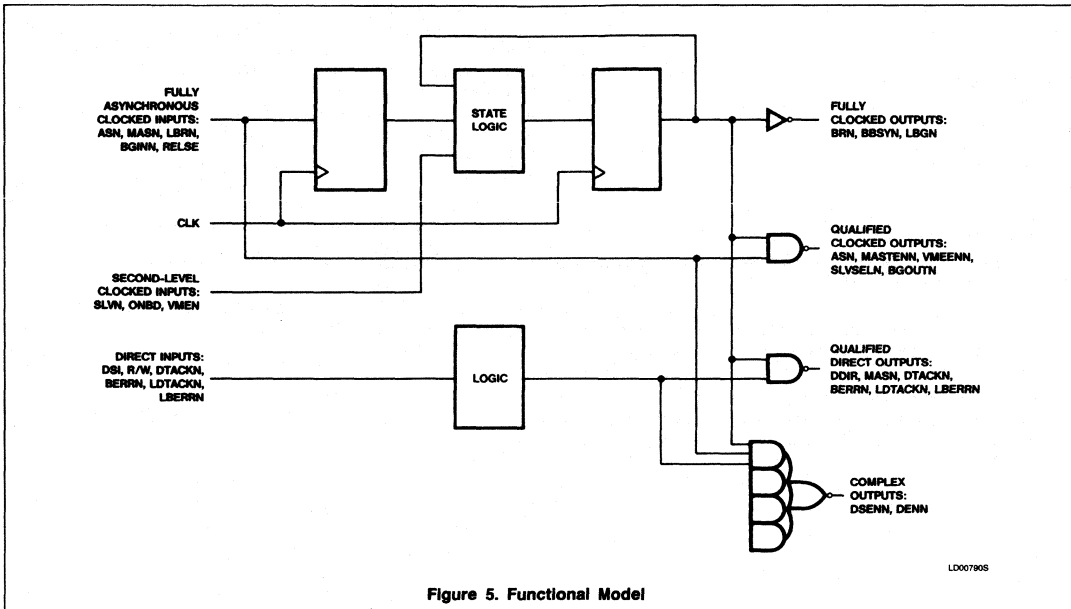

Figure 4. DMAC-Type Master/Slave Application



# VMEbus Controller (BUSCON)

# SCB68172



## VMEbus Controller (BUSCON)

SCB68172

BGINN low at any other time, it drives BGOUTN low and continues to do so until BGINN goes high.)

Once BUSCON has driven BBSYN low, it waits for any current VMEbus cycle to complete as evidenced by ASN high. Then it begins to drive ASN (initially high) and drives VMEENN low to enable the address out onto the VMEbus.

If the BRN was initiated by MASN, BUSCON then waits two clock periods for address setup time before driving ASN low. If the bus acquisition was initiated by LBRRN, it waits for MASN.

BUSCON will release the BBSYN signal on a rising clock edge at which all of the following conditions are met:

1. It is at least three clock periods after the edge on which BBSYN was asserted, and
2. Any prior master's cycle has completed and VMEENN has been driven low, and
3. The BGINN input was high on the last rising clock edge, and
4. The RELSE input was high on the last rising clock edge, and
5. It is not the clock edge at which BUSCON asserts ASN, and
6. It is not the clock edge at which BUSCON withdraws ASN, and
7. LBRRN was high on the last rising clock edge.

If BBSYN is released while BUSCON is not driving ASN low, then VMEENN goes high when BBSYN is released, to release the VMEbus. Otherwise, VMEENN goes high shortly before ASN goes high.

RELSE is provided to allow user determination of the method of VMEbus release. The BGACKN output of a DMA controller can be connected to (or included in) this signal to allow the device to control how long it keeps the bus. The OR of the VMEbus requests can be connected to (or included in) this signal for release on request (ROR) operation. If RELSE is connected to a constant logic high, BUSCON will release the bus as soon as possible; i.e. during the first bus cycle.

### VMEbus MASTER OPERATION

When the BUSCON has VMEbus control, VMEbus cycles indicated on MASN and VMEN produce ASN low on the VMEbus. DDIR and DENN control the VMEbus data transceivers. DDIR reflects the R/WN line.

In a write operation, DENN is driven low to drive data onto the VMEbus whenever the BUSCON has control of the VMEbus, R/WN is low, and the previous VMEbus slave has released DTACKN and BERRN to high. (The DTACKN/BERRN requirement does not ap-

ply to subsequent cycles among consecutive writes, if R/WN is maintained continuously low.) DSENN is then driven low when DENN has been low for more than a clock period, and DTACKN and BERRN are high, but not before ASN is driven low. DSENN goes high after DSI goes low or MASN goes high, whichever occurs first. DENN goes high after R/WN goes high, or with VMEENN going high, whichever occurs first.

In a read operation (R/WN is high), DENN goes low to drive data in from the VMEbus after ONBD and VMEN have been sampled, DSI is high, and MASTENN is low. DSENN goes low after DSI, DTACKN, and BERRN are all high, but not before ASN goes low. DSENN and DENN go high after DSI goes low or MASN goes high, whichever occurs first.

DTACKN and BERRN are inputs and drive LDTACKN and LBERRN as outputs. LDTACKN and LBERRN are released when the onboard master makes DSI low. If the VMEbus slave continues to hold DTACKN or BERRN low thereafter, DSENN, LDTACKN and LBERRN are inhibited for the next cycle until the response is released.

MASTENN and VMEENN are kept low while the BUSCON has VMEbus control. The MASTO-AS delay thus provides automatic address-setup time for subsequent VMEbus cycles.

The need to transceive the data strobes in a master/slave application, plus qualify the onboard master's strobes with DSENN for output, can be accomplished in several ways as shown in Figure 7.

### MASTER/SLAVE SWITCHING

BUSCON includes arbitration and switching logic between VMEbus slave cycles and onboard master cycles (to a shared onboard slave or the VMEbus). The logic remains in its previous direction until forced to switch by another cycle. This provides minimum overhead for slave-only or master-only operation, and for consecutive cycles from the same master.

If a master cycle to a shared slave occurs, or BGINN arrives when requesting the VMEbus, after a slave cycle with another VMEbus master, VMEENN goes high to disable the address from the VMEbus. On the next clock edge, MASTENN goes low to enable the master's address back out onto the onboard bus.

For a VMEbus master cycle, if the current VMEbus cycle is also over, VMEENN then goes low to enable the address out onto the VMEbus.

For a master cycle to a shared slave, SLVSELN goes low one clock period after

MASTENN goes low, or if the master direction is continuing, after ONBD is sampled high. SLVSELN goes high shortly after MASN goes high. DTACKN and BERRN are isolated from LDTACKN and LBERRN. DSENN is kept high. DENN is kept high except in a write cycle when BUSCON has VMEbus control.

If an onboard master cycle and VMEbus slave cycle both arrive for the shared slaves within the same clock period, the previous direction of the master/slave switch is retained.

### VMEbus SLAVE OPERATION

If a VMEbus slave cycle occurs after a master cycle, or while BUSCON is requesting the VMEbus, MASTENN goes high, and on the subsequent clock VMEENN goes low to enable the VMEbus address and control signals onto the board.

SLVSELN goes low one clock period after VMEENN goes low, to signal the shared slave(s) that a cycle is occurring. If the slave mode is continuing, SLVSELN goes low after SLVN is sampled low. SLVSELN goes high shortly after ASN goes high.

DDIR reflects R/WN (in the opposite sense from master operation). LDTACKN and LBERRN are inputs and drive DTACKN and BERRN as outputs.

In write operations, DENN is driven low (to enable data in) whenever R/WN is low and LDTACKN and LBERRN are high. When switching between master and slave operation with R/WN low, DENN sequences like VMEENN.

In read operations, DENN is driven low (to enable data out) after SLVN has been sampled low, and while R/WN and DSI are both high.

### SLAVE-ONLY USE

This is the simplest application of the BUSCON. However, handling of board-selection logic from a simple VMEbus address decode, plus driving and sequencing of DTACKN and BERRN, can save VMEbus designers cost and board space even in this application.

### SLAVE DESIGN

In the MS and S configurations, slaves operate off the data strobes and SLVSELN rather than address and data strobes. It should be noted that SLVSELN will typically go low after the data strobes go low. Data should not be written nor placed on the data lines until SLVSELN goes low.

# VMEbus Controller (BUSCON)

SCB68172

## 68000 DUAL-PORTED OPERATION

BUSCON is ideal for use on a VMEbus board containing a 68000 processor. The obvious approach to dual-porting memory and other slaves, on a board with a 68000, is to use the BRN input of the 68000 to suspend processor operation while another master accesses the onboard slave. This works fine except when the processor has already started a cycle for the VMEbus. This latter incident threatens a "deadlock" situation and requires that the processor be "rolled back" off the board's shared bus so that the other master's cycle can occur first. The 68000 has a feature which can be used for this; assertion of both its BERRN and HALTN inputs cause it to suspend operation and retry the cycle when the inputs are released.

The BUSCON does not use these features because there is a flaw in the retry logic. The retry logic does not function during an indivisible RMW sequence (TAS instruction), even in the read cycle. Instead, the assertion of BERRN and HALTN causes an actual bus

error exception. It is believed that there is no reliable and general programming solution to the problem of finding the start of the TAS instruction for restart. With 6801x processors, the situation is better because the TAS can be restarted. In any case BUSCON elects to isolate the processor with a few more packages rather than adding complexity to the error-handling software because of dual-ported design.

## DMA USE

The BUSCON can be used for VMEbus boards which contain a DMA controller but no processor. Such DMA applications are always master/slave due to the need to program the DMA controller from the VMEbus. There are two operational features of the SCB68172 that are intended for use with DMA controllers. First, the LBRN input can be used to request control of the VMEbus directly, rather than waiting for MASN low and VMEN low as in a processor application. Second, the SCB68172 samples the state of the LBGN pin when RESETN is low. If LBGN is low at

the end of RESETN, MASN is used as an input only. If LBGN is high (at the end of the RESETN pulse), the BUSCON thereafter drives the state of VMEbus ASN onto MASN whenever it does not have control of the VMEbus.

For 68000 family DMA controllers, MASN is connected directly to the controller's address strobe pin. The VMEbus ASN-to-MASN feature satisfies the requirement of some DMA controllers that ASN be low on cycles which program them, and also serves to delay the activity of a controller which gets an LBGN response during the last VMEbus cycle by another master.

When LBRN is sampled low, if the BUSCON has retained VMEbus control from previous DMA activity, it continues to retain control for the duration of LBRN being low, and drives LBGN low on the next clock.

Otherwise, it drives VMEbus BRN low on the next clock. When BGINN is sampled low, BBSYN is driven low on the next clock. LBGN is driven low on the same clock as BBSYN if VMEbus ASN is high. If ASN is low, LBGN is

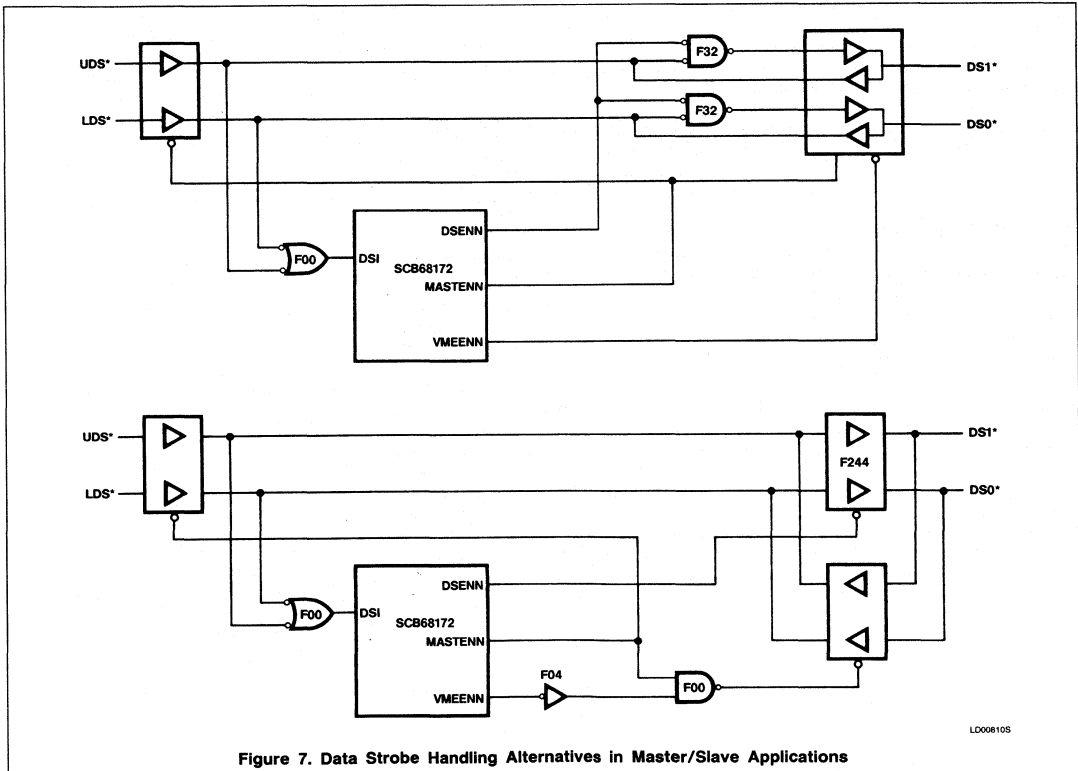

Figure 7. Data Strobe Handling Alternatives in Master/Slave Applications

LD00810S

## VMEbus Controller (BUSCON)

## SCB68172

driven low one clock after BBSYN, except when ASN low and BGINN are both sampled low for the first time in the same clock period and the VMEbus cycle addresses this board – in this last case, LBGN is driven low two clocks after BBSYN. In either of the last two cases, VMEbus ASN low makes MASN low before LBGN goes low, which keeps the DMA controller from starting until the current VMEbus cycle is over.

Note that the local bus request/grant logic and ASN-to-MASN drive features are separate capabilities, either or both of which can be used in applications not involving a DMA controller. However, note also that when the state of the ASN is driven onto MASN, it is done without conditioning by the state of the master-slave switch. This means MASN can go low before MASTENN and VMEENN have been cycled to bring the VMEbus address onto the board. (The low state of SLVSELN indicates that the VMEbus address is valid on the board.)

DMA applications are always considered master/slave due to the need to program the DMA controller. The BUSCON assumes that it must always have VMEbus control before answering an LBRN with LBGN. If this is not desired; i.e., if the DMA controller will sometimes be programmed to do onboard transfers solely and the designer wishes to optimize for this case, then a processor-type interface should be used, and isolation devices and additional onboard logic are required.

### INTERRUPT HANDLING

When a processor handles interrupts from onboard sources and from the VMEbus, the design must include logic to decide whether an interrupt acknowledge cycle is an onboard or offboard cycle. This logic is quite different from the address decoding logic used to make this decision on other cycles.

Performance can be maximized if the interrupt logic can provide ONBD and VMEN within the specified time after MASN goes low, or if the signals can be made to meet their specified setup and hold times for CLK. In this case ONBD and VMEN need be selected between the IACK and non-IACK sources. Otherwise (i.e., if the interrupt logic presents these signals slowly and asynchro-

nously), MASN must also be selected between the IACK and non-IACK sources.

### MASTER BLOCK TRANSFER

The block transfer feature of the VMEbus allows considerable performance improvement for transferring a block of consecutive memory locations. The BUSCON can be used for block transfer operations in the master role.

Master block transfers are applicable to cache subsystems or block transfer on processor boards, and to DMAC-type designs. The only requirements for master block transfers operation with the BUSCON are that external logic must place a block transfer address modifier (AM) code on the VMEbus, and then hold MASN low across a number of data strobes. (Note that a long block transfer can compromise the operation of other VMEbus masters. One strategy to avoid such problems could be to do a minimum of 4 or 8 transfers without interruption, and then switch to release on request (ROR) operation.)

A sample circuit for master block transfers is shown in Figure 8. Here, a block transfer is triggered whenever the DMAC accesses a certain range of addresses. The SEQ signal could of course be generated in other ways.

### SLAVE BLOCK TRANSFERS

VMEbus slaves that are capable of block transfers latch the bus address into a set of counters on the leading edge of ASN, and then increment the address for each data transfer. The SCB68172 can be used on such slave boards in accordance with revision C of the VMEbus specification.

The revision C specification introduces a limitation on block transfers, namely that a master is not allowed to continue a block transfer across a 256-byte boundary. This limitation has a number of advantages, including reducing the number of counter devices needed on slave boards, allowing straightforward use of page or static column modes on dynamic memories, providing periodic windows in a long block transfer in which higher-priority masters can gain bus control, and (effectively) preventing a block transfer from crossing from one slave board to another.

It is this last advantage that is of particular importance for the SCB68172. It means that VMEbus slaves can make a positive selection-decision after ASN goes low, and this decision will remain valid for the duration of the cycle even if it is a block transfer cycle.

In a block transfer which selects an SCB68172-based slave board, SLVSELN remains low through the block, until ASN goes high. The onboard slave logic then uses the data strobes to define each data transfer.

The data strobe and acknowledge signals are handled in a high-speed combinatorial fashion by the SCB68172 in both the master and slave roles. Block transfers are inherently faster on the VMEbus because the address need be passed and decoded only once, and because the slave can look ahead (pipeline) subsequent transfers in a block read cycle. With the SCB68172, this inherent speed advantage is augmented by the advantage of combinatorial over sequential (arbitrated) logic.

### 3-STATE ENABLE SWITCHING (MASTENN, VMEENN, DENN)

As a result of speed optimization of master/slave switching, some parts used in PMS applications may exhibit short high-going transients on MASTENN, VMEENN, and/or DENN, if requests for access to the shared slave(s) arrive closely in time from both the onboard master and the VMEbus master. These transients should pose no problem as long as the signals are used as intended (i.e., as 3-State enables). The following points apply:

1. A transient will occur only when SLVSELN has been high for at least one clock period, and at least one clock period before a subsequent low on SLVSELN.
2. A transient will occur only if the current master/slave direction is maintained.
3. Low-going transients (which could cause tristate conflicts) do not occur.
4. Commonly such transients will be eliminated by external capacitance, and/or rejected by receivers on other parts. In any case the logic levels on signals controlled by these enable signals should not be affected.
5. Edge-sensitive use of these signals is inadvisable in a PMS application.

VMEbus Controller (BUSCON)

SCB68172

**2**

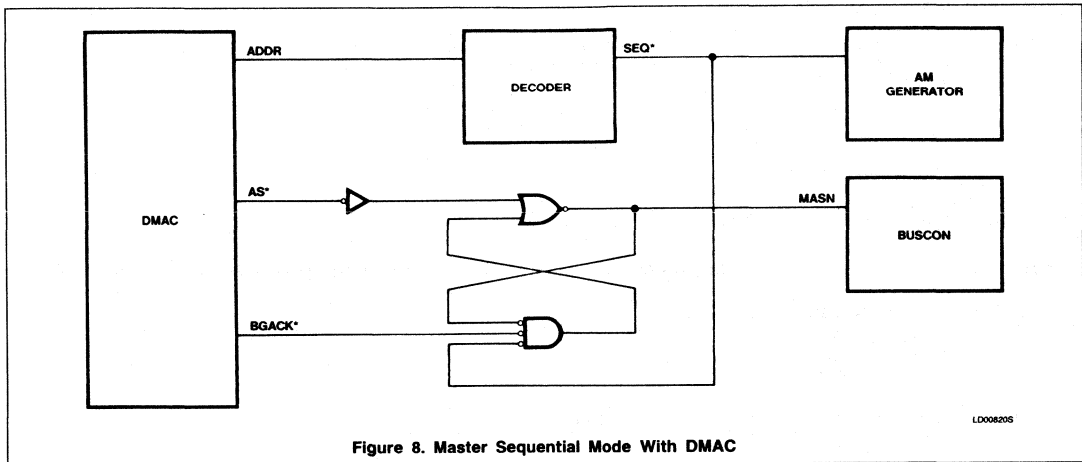
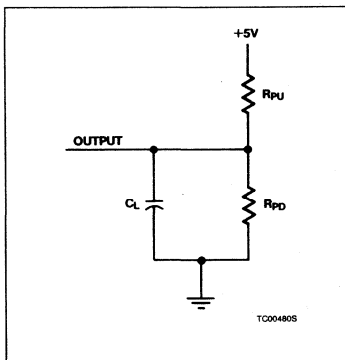

Figure 8. Master Sequential Mode With DMAC

**TEST CONDITIONS**

Unless otherwise noted, the following timing parameters are based on loading as follows:



SIGNALS	R <sub>PU</sub>	R <sub>PD</sub>	C <sub>L</sub>
ASN, BRN, BBSYN, DTACKN, BERRN, LDTACKN, LBERRN, LBGN, BGOUTN, VMEENN, SLVSELN, DSENN, DENN, DDIR	150	235	300
MASTENN	2K	N/A	15
MASN	280	N/A	45
	180	1K	45

## VMEbus Controller (BUSCON)

SCB68172

ABSOLUTE MAXIMUM RATINGS<sup>1</sup>

SYMBOL	PARAMETER	RATING	UNIT
V <sub>S</sub>	Supply voltage range	-0.5 to +7	V
V <sub>IN</sub>	Input voltage range	-0.5 to +5.5	V
T <sub>A</sub>	Operating temperature range <sup>2</sup>	0 to +70	°C
T <sub>STG</sub>	Storage temperature range	-65 to +150	°C

DC ELECTRICAL CHARACTERISTICS V<sub>CC</sub> = 5V ± 5%, T<sub>A</sub> = 0°C to +70 °C<sup>3, 4</sup>

SYMBOL	PARAMETER	TEST CONDITIONS	LIMITS		UNIT
			Min	Max	
<b>DSI, ONBD, SLVN, VMEN, LBRN, RELSE, RESETN</b>					
I <sub>IL</sub>	Input low current	V <sub>IN</sub> = 0.4V		-400	μA
I <sub>IH</sub>	Input high current	V <sub>IN</sub> = 2.7V		20	μA
V <sub>IL</sub>	Input low voltage			0.8	V
V <sub>IH</sub>	Input high voltage		2		V
<b>ASN, MASN, BGINN, DTACKN, BERRN, LDTACKN, LBERRN</b>					
I <sub>IL</sub>	Input low current	V <sub>IN</sub> = 0.4V		-400	μA
I <sub>IH</sub>	Input high current	V <sub>IN</sub> = 2.7V		20	μA
V <sub>TH+</sub>	High-going threshold voltage		1	1.65	V
V <sub>TH-</sub>	Low-going threshold voltage		0.8	1.15	V
V <sub>TH+</sub> - V <sub>TH-</sub>	Hysteresis		0.2		V
<b>R/WN, CLK</b>					
I <sub>IL</sub>	Input low current	V <sub>IN</sub> = 0.4V		-800	μA
I <sub>IH</sub>	Input high current	V <sub>IN</sub> = 2.7V		40	μA
V <sub>IL</sub>	Input low voltage			0.8	V
V <sub>IH</sub>	Input high voltage		2		V
<b>BGOUTN, VMEENN, SLVSELN, DSENN, DENN, DDIR (low current totem pole)</b>					
V <sub>OL</sub>	Output low voltage	I <sub>OL</sub> = 8mA, V <sub>CC</sub> = 4.75V		0.5	V
V <sub>OH</sub>	Output high voltage	I <sub>OH</sub> = -0.4mA, V <sub>CC</sub> = 4.75V	2.7		V
I <sub>OS</sub>	Short-circuit output current	V <sub>OUT</sub> = 0V	-15	-100	mA
<b>MASTENN (high current totem pole)</b>					
V <sub>OL</sub>	Output low voltage	I <sub>OL</sub> = 24mA, V <sub>CC</sub> = 4.75V		0.5	V
V <sub>OH</sub>	Output high voltage	I <sub>OH</sub> = -2.6mA, V <sub>CC</sub> = 4.75V	2.4		V
V <sub>OH</sub>	Output high voltage	I <sub>OH</sub> = -1mA, V <sub>CC</sub> = 4.75V	2.7		V
I <sub>OS</sub>	Short-circuit output current	V <sub>OUT</sub> = 0V	-40	-100	mA
<b>MASN (low current tristate)</b>					
V <sub>OL</sub>	Output low voltage	I <sub>OL</sub> = 8mA, V <sub>CC</sub> = 4.75V		0.5	V
V <sub>OH</sub>	Output high voltage	I <sub>OH</sub> = -0.4mA, V <sub>CC</sub> = 4.75V	2.7		V
I <sub>OS</sub>	Short-circuit output current	V <sub>OUT</sub> = 0V	-15	-100	mA
I <sub>OZL</sub>	3-State-off leakage current, low level	V = 0.4V		-21	μA
I <sub>OZH</sub>	3-State-off leakage current, high level	V = 2.7V		20	μA
<b>ASN (high current tristate)</b>					
V <sub>OL</sub>	Output low voltage	I <sub>OL</sub> = 64mA, V <sub>CC</sub> = 4.75V		0.5	V
V <sub>OH</sub>	Output high voltage	I <sub>OH</sub> = -7.8mA, V <sub>CC</sub> = 4.75V	2.4		V
V <sub>OH</sub>	Output high voltage	I <sub>OH</sub> = -3mA, V <sub>CC</sub> = 4.75V	2.7		V
I <sub>OS</sub>	Short-circuit output current	V <sub>OUT</sub> = 0V	-120	-300	mA
I <sub>OZL</sub>	3-State-off leakage current, low level	V = 0.4V		-60	μA
I <sub>OZH</sub>	3-State-off leakage current, high level	V = 2.7V		60	μA

## VMEbus Controller (BUSCON)

SCB68172

## DC ELECTRICAL CHARACTERISTICS (Continued)

SYMBOL	PARAMETER	TEST CONDITIONS	LIMITS		UNIT
			Min	Max	
<b>LDTACKN, LBERRN, LBGN (low current open collector)</b>					
V <sub>OL</sub>	Output low voltage	I <sub>OL</sub> = 8mA, V <sub>CC</sub> = 4.75V V = 5.5V		0.5	V
I <sub>OH</sub>	Output leakage current			100	μA
<b>DTACKN, BERRN, BRN, BBSYN (high current open collector)</b>					
V <sub>OL</sub>	Output low voltage	I <sub>OL</sub> = 40mA, V <sub>CC</sub> = min I <sub>OL</sub> = 70mA, V <sub>CC</sub> = min V = 2.7V V = 5.5V		0.4	V
V <sub>OL</sub>	Output low voltage			0.5	V
I <sub>OH</sub>	Output leakage current			60	μA
I <sub>OH</sub>	Output leakage current			250	μA
I <sub>CC</sub>	V <sub>CC</sub> Supply current	V <sub>CC</sub> = Max		180	mA

## NOTE:

- Stresses above those listed under Absolute Maximum Ratings may cause permanent damage to the device. This is stress rating only and functional operation of the device at these or at any other conditions other than those indicated in the Electrical Characteristics section of this data sheet is not implied.
- For operating at elevated temperatures, the device must be derated based on +150°C maximum junction temperature.
- Parameters are valid over specified temperature range.
- All voltage measurements are referenced to ground (V<sub>SS</sub>). For testing, all signals swing between 0.4V and 2.4V with a transition time of 10ns maximum. All time measurements are referenced at input voltages of 0.8V and 2V as appropriate.

AC ELECTRICAL CHARACTERISTICS V<sub>CC</sub> = 5V ± 5%, T<sub>A</sub> = 0°C to +70°C<sup>3, 4</sup>

NO.	FIGURE	CHARACTERISTIC	TENTATIVE LIMITS		UNIT	NOTES
			Min	Max		
<b>Clock and general parameters</b>						
*1	9-18, 20	CLK cycle time (clk)	40		ns	
*2	9-18, 20	CLK low time	15		ns	
*3	9-18, 20	CLK high time	15		ns	
<b>Asynchronous input setup time to CLK high</b>						
4	9, 10, 11, 12, 13, 18, 20	ASN, MASN low	15		ns	5
5	9, 10, 11, 13	ASN, MASN high	14		ns	5
*6	9, 10, 11, 12, 13, 20	SLVN, VMEN low	25		ns	6
*7	11, 17, 18	SLVN, VMEN high	20		ns	6
*8	9, 10, 13	ONBD low	25		ns	6
9	18	ONBD high	25		ns	6
10	13, 16, 20	LBRN, RELSE, BGINN low	9		ns	5
11	14, 15	LBRN, RELSE, BGINN high	11		ns	5
12	11, 12, 13	DSI low (end of slave cycle)	16		ns	5
<b>Asynchronous input hold time from CLK high</b>						
13		ASN, MASN, DSI	0		ns	7
14		ONBD, VMEN	0		ns	8
15		LBRN, RELSE, BGINN	2		ns	7
<b>Propagation, CLK high to:</b>						
16	16	BGOUTN low	12	27	ns	
17	20	LBGN low	12	30	ns	
18		LBGN high	16	41	ns	
19	13, 16, 20	BBSYN, BRN low	17	37	ns	
20	13, 20	BBSYN, BRN high (C <sub>L</sub> = 50) (C <sub>L</sub> = 300)	20 40	47 68	ns	
21	9, 10, 13	ASN low	15	37	ns	
22	9, 10	ASN high	13	31	ns	
23	11, 12, 13, 18, 20	SLVSELN, VMEENN low	14	35	ns	
24	13, 18, 20	MASTENN low	15	38	ns	
<b>Miscellaneous</b>						
*25		RESETN width low	6clk		ns	9
26	16	BGINN low to BGOUTN low	clk+10	2clk+35	ns	
27	16	BGINN high to BGOUTN high	3	10	ns	
*28	9, 11	R/WN high to DSI high (start of read cycle)	10		ns	
*29	9, 12	DSI low to RWN low (end of read cycle)	10		ns	

## NOTE:

- \* These AC Electrical Characteristics have been tested and characterized, and therefore are considered limits, not tentative limits.

## VMEbus Controller (BUSCON)

SCB68172

## AC ELECTRICAL CHARACTERISTICS (Continued)

NO.	FIGURE	CHARACTERISTIC	TENTATIVE LIMITS		UNIT	NOTES
			Min	Max		
<b>Address decoding</b>						
30	11, 12, 13, 20	ASN low to SLVN valid		clk-5	ns	
31	9, 10, 13, 18	MASN low to VMEN valid		clk-5	ns	
32	9, 10, 13, 18	MASN low to ONBD valid		clk-7	ns	
33	17	SLVN high after DTACKN low	14		ns	
34	9, 10	VMEN, ONBD valid after MASN high	6		ns	
35	9, 10	MASN high	15		ns	10
36	9, 10, 11	DSI low	20		ns	
37	11	ASN high	20		ns	10
<b>VMEbus acquisition</b>						
38	13	MASN low to BRN low	clk+15	2clk+45	ns	11
*38A	13, 20	ASN low to BGINN low (early release by other master)	10		ns	
39	13, 20	BGINN low to BBSYN low	clk+15	2clk+45	ns	
40	13, 20	BBSYN low to BRN high	0	50	ns	
41	13	BGINN low to VMEENN low, DENN low (write)	clk+12	2clk+40	ns	12
42	13	ASN high to VMEENN low, DENN low (write)	11	31	ns	12,13
43	13	VMEENN low to ASN low	2clk-10	2clk+15	ns	14
*43A	13, 16, 20	BBSYN or BGOUTN low to BGINN high	0		ns	
<b>VMEbus master cycles</b>						
44	9, 10	ASN high (successive VMEbus master cycles)	2clk-15		ns	14
45	9, 10	MASN low to ASN low (subsequent cycle retaining VMEbus control)	clk+13	2clk+45	ns	14
46	9, 10	ASN low to DSENN low	-4	5	ns	17, 18
47	10, 13	R/WN low to DDIR high	6	15	ns	
48	10, 13	DDIR high to DENN low (write)	2	7	ns	15
49	10	DTACKN and BERRN high to DENN low (write, 1st bus cycle or preceded by read)	7	21	ns	15
50	10	DENN low to DSENN low (write)	clk+10	2clk+40	ns	17
51	9, 11, 13	R/WN high to DDIR low	6	16	ns	
52	9	DDIR low to DENN low (read)	5		ns	16
53	9	DSI high to DENN low (read)	8	18	ns	16
54	9	DSI high to DSENN low (read)	8	18	ns	18
55	9, 10	DTACKN and BERRN high to DSENN low	6	19	ns	17, 18
56	9, 10	DTACKN or BERRN low to LDACKN or LBERRN low	6	17	ns	
*57	9, 10	LDACKN or LBERRN low to DSI low or MASN high	0		ns	
58	9, 10	DSI low to DSENN high	7	16	ns	19
59	9, 10	MASN high to DSENN high	13	28	ns	
60	10	R/WN high to DSENN high (after a write)	5	14	ns	20
61	9, 10	MASN high to ASN high (unless early release)	clk+11	2clk+38	ns	
62	9	MASN high to DENN high (read)	13	28	ns	21
63	9	DSI low to DENN high (read)	7	16	ns	21
64	10	R/WN high to DENN high (write)	5	14	ns	22
65	9, 10	DSENN high to LDACKN and LBERRN high	7	24	ns	23
66	9, 10	DTACKN and BERRN high to LDACKN and LBERRN high	7	23	ns	23
<b>VMEbus release</b>						
*67	14	BBSYN low	2clk		ns	
68	14, 15	BGINN high to BBSYN high	clk+18	2clk+70	ns	24
69	14, 15	RELSE high to BBSYN high	clk+20	2clk+72	ns	24
70	14	ASN low to BBSYN high (early release)	clk-25		ns	
71	14	MASN high to VMEENN high (early release)	8	20	ns	
72	14	MASN high to DENN high (early release, write)	8	20	ns	
73	14	DENN (write) and VMEENN high to ASN high (early release)	5	15	ns	
74	14	ASN high to ASN released (early release)	5	20	ns	
75	15	ASN high to BBSYN high (intercycle release)	clk-10		ns	
76	15	DENN (write) and VMEENN high to BBSYN high (intercycle release)	5	30	ns	
*77	14, 15	BBSYN high to RELSE low	0		ns	

## NOTE:

\* These AC Electrical Characteristics have been tested and characterized, and therefore are considered limits, not tentative limits.



## VMEbus Controller (BUSCON)

SCB68172

## AC ELECTRICAL CHARACTERISTICS (Continued)

NO.	FIGURE	CHARACTERISTIC	TENTATIVE LIMITS		UNIT	NOTES
			Min	Max		
<b>Master to slave switching</b>						
78	11, 13, 20	(External) ASN low to MASTENN high	10	clk+40	ns	25
79	11, 13, 20	SLVN low to MASTENN high	7		ns	25
80	11	SLVSELN high to MASTENN high	7		ns	25
81	11, 20	MASTENN high to VMEENN low	14	clk+36	ns	
81A	11, 13	VMEENN low to DDIR change	-5	+5	ns	
82	11, 13, 20	VMEENN low to SLVSELN low	clk-11	clk-5	ns	26
<b>VMEbus slave cycles</b>						
83	12	SLVSELN high (successive slave cycles)	2clk-5		ns	26
84	12	ASN low to SLVSELN low (already in slave state)	clk+12	2clk+40	ns	26
85	12, 13	R/WN low to DDIR low	6	14	ns	
86	12, 13	DDIR low to DENN low (write)	5	12	ns	27
87	12	LDTACKN and LBERRN high to DENN low (write)	7	20	ns	27
88	12, 13	R/WN high to DDIR high	5	14	ns	
89	11	DDIR high to DENN low (read)	2	7	ns	28
90	11	ASN low to DENN low (read)	clk+20	2clk+47	ns	28
91	11	DSI high to DENN low (read)	6	16	ns	28
*92	11, 12, 13, 18	SLVSELN low and DSI high to LDTACKN or LBERRN low	0		ns	29
93	11, 12, 13, 18	LDTACKN or LBERRN low to DTACKN or BERRN low	10	20	ns	
94	12, 13	LDTACKN or LBERRN low to DENN high (write)	9	22	ns	
*94A	11, 12, 13, 18	DTACKN or BERRN low to DSI low or ASN high	0		ns	
95	11	DSI low to DENN high (read)	7	16	ns	
96	11, 12, 18, 20	ASN high to SLVSELN high	13	28	ns	
97	11, 12, 13	DSI low to DTACKN and BERRN high	17	37	ns	
		( $C_L = 50$ )	37	60	ns	
		( $C_L = 300$ )	0	35	ns	30, 32
*98	11, 12, 13, 20	DSI low to LDTACKN and LBERRN high	0		ns	30
*99	11, 12	LDTACKN and LBERRN high to (next) DSI high	0		ns	30
<b>Slave to master switching</b>						
100	18	MASN low to VMEENN, DENN (VMEbus slave write) high	18	clk+47	ns	31
101	18	ONBD high to VMEENN, DENN (VMEbus slave write) high	8	24	ns	31
102		VMEENN low to VMEENN, DENN (VMEbus slave write) high	18	21	ns	31
*103	13, 18, 20	SLVSELN high to VMEENN, DENN (VMEbus slave write) high	0		ns	31
104	13, 20	DSI low (selected) to VMEENN, DENN (VMEbus slave write) high	14	clk+40	ns	31
105	13, 18, 20	VMEENN high to MASTENN low	24	clk+20	ns	
107	13, 20	MASTENN low to VMEENN low, DENN low (write, if next cycle on VMEbus)	3		ns	12,15
108	18	MASTENN low to SLVSELN low (if next cycle on board)	clk-13	clk	ns	33
<b>Onboard cycles</b>						
109	18	SLVSELN high (successive onboard cycles)	3clk+4		ns	33
110	18	MASN low to SLVSELN low (MASTENN already low)	clk+17	2clk+42	ns	33
111	18	MASN high to SLVSELN high	12	26	ns	

## NOTE:

\* These AC Electrical Characteristics have been tested and characterized, and therefore are considered limits, not tentative limits.

## VMEbus Controller (BUSCON)

SCB68172

## AC ELECTRICAL CHARACTERISTICS (Continued)

NO.	FIGURE	CHARACTERISTIC	TENTATIVE LIMITS		UNIT	NOTES
			Min	Max		
<b>DMAC-Type operation</b>						
112	19	BBSYN high to MASN active ( $C_L = 50$ )	0	5	ns	34
		( $C_L = 300$ )	-25	-15	ns	34
113	19	ASN high to MASN active	13	40	ns	34
114	19	ASN low to MASN low	10	25	ns	
115	19	ASN high to MASN high	6	16	ns	
116	19	ASN high to MASN released	12	32	ns	35
117	19	LBGN low to MASN released	5	12	ns	35
118	20	LBRRN low to BRN low (if BBSYN released)	clk+15	2clk+45	ns	
119		LBRRN low to LBGN low	clk+10	2clk+37	ns	36
120	20	BGINN low to LBGN low (ASN high)	clk+15	2clk+45	ns	
		(ASN low)	2clk+15	3clk+45	ns	
121	20	MASN low (output) to LBGN low	2clk+12		ns	
*122	20	LBGN low to LBRRN high	0		ns	
123	20	LBRRN high to LBGN high	clk+14	2clk+48	ns	37
124	14, 15	LBRRN high to BBSYN high ( $C_L = 50$ )	clk+18	2clk+55	ns	24
		( $C_L = 300$ )	clk+35	2clk+75	ns	24
125	20	ASN high to LBGN high (selected)	2clk+18	3clk+50	ns	37
126	20	DSI low to LBGN high (selected)	2clk+20	3clk+52	ns	37

**NOTE:**

\* These AC Electrical Characteristics have been tested and characterized, and therefore are considered limits, not tentative limits.

**NOTES:**

- These setup times guarantee recognition at a rising edge of CLK, but the device will operate correctly if they are not met. If the asynchronous input is changed between the setup and hold times, the new state of the input may be recognized at this clock or the following clock.
- These setup times are required on the rising edge of CLK following the one on which ASN or MASN is first recognized low. If parameters 30, 31, and 32 are met, these parameters are automatically guaranteed.
- These hold times guarantee (continued) recognition of the signal state at a rising edge of CLK, but the device will operate correctly if they are not met.
- These hold times are required on the rising edge of CLK preceding the one on which MASN is first recognized high. Parameter 34 provides a more straightforward requirement which guarantees these times.
- This parameter applies after  $V_{CC}$  and the clock signal are both within the specified limits.
- These minimum times are to guarantee recognition. Operation will be limited by 44, 83, and 109 if the strobe is high for less than 2clk.
- BRN is driven low, and this acquisition sequence applies, only if BBSYN is high.
- VMEEEN is driven low only when 41, 42, and 107 have been met.
- Applies to ASN of VMEbus cycle which does not select this board as a slave.
- ASN goes low when 43, 44, and 45 are met. 44 is not applicable on the first cycle after acquiring the VMEbus.
- In a write operation, DENN goes low when 41, 42, 48, 49, and 107 are met. 49 does not apply for subsequent cycles in a series of writes if R/WN is held low throughout.
- In a read operation, DENN goes low when 52 and 53 are met.
- In a write operation, DSENN goes low when 46, 50, and 55 are met. 55 is significant only for subsequent cycles in a series of writes with R/WN held low throughout.
- In a read operation, DSENN goes low when 46, 54, and 55 are met.
- DSENN goes high when either 58 or 59 is met.
- Applies only if R/WN remains low after a write cycle, so that DSENN goes low again.
- In a read operation, DENN goes high when either 63 or 64 is met.
- In a write operation, DENN goes high when either 64 or 71 is met.
- LDTACKN and LBERRN go high when either 65 or 66 is met.
- BBSYN is always released in response to BGINN, RELSE, and LBRRN all high. However, if this condition is detected during a clock period in which the decision to change ASN is made, the release of BBSYN is delayed one clock period so that 70 or 75 is met.
- MASTENN goes high when 78, 79, and 80 are all met.
- SLVSELN goes low when 82, 83, and 84 (as applicable) are met.
- In a write operation, DENN goes low when 86 and 87 are met.
- In a read operation, DENN goes low when 89, 90, and 91 are met.
- The onboard slave(s) should wait for both SLVSELN and DSI before driving a response.
- Since BUSCON itself terminates DTACKN and BERRN when DSI goes low, the onboard slaves must meet this requirement to assure that a "lingering" LDTACKN or LBERRN is not presented as DTACKN or BERRN when the next DSI occurs. 98 is the real requirement - 98 max is derived from it, plus the 40ns minimum high time of VMEbus data strobes and an allowance for receiver skew.
- VMEEEN goes high only when 100, (101 or 102), 103, and 104 are met. 104 applies only if a VMEbus slave cycle (with this board) is ending. The onboard slave(s) must meet this requirement so that the local response is not inadvertently presented to the onboard master.
- SLVSELN goes low when 108, 109, and 110 (as applicable) are met.
- MASN is driven out of Hi-Z state only when 112 and 113 are met.
- MASN is released to Hi-Z state only when 116 and 117 are met.
- The max Figure applies only if BUSCON has kept VMEbus control (i.e., if BBSYN is low).
- LBGN goes high only when 123, 125, and 126 are met, but 125 and 126 apply only if a VMEbus slave cycle (with this board) is in progress.

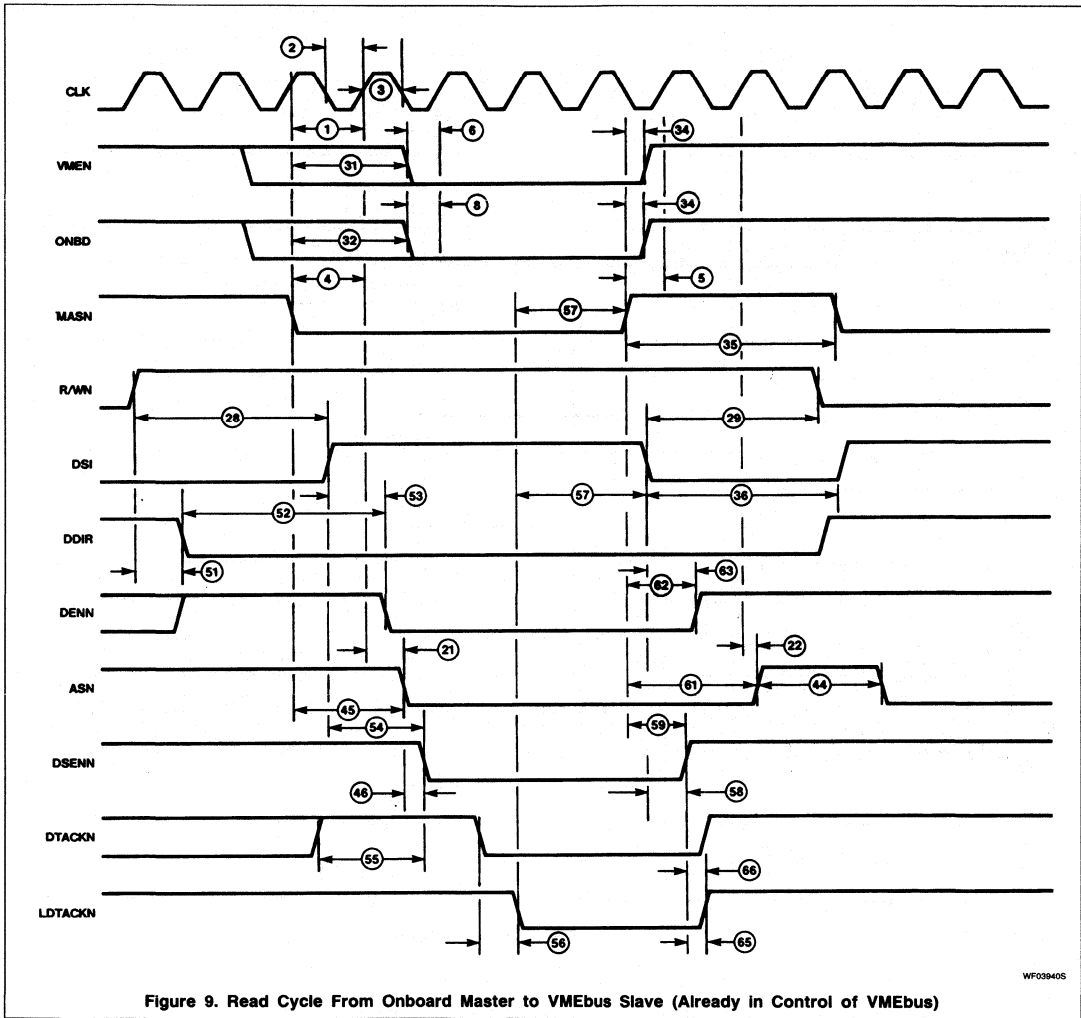

VMEbus Controller (BUSCON)

SCB68172

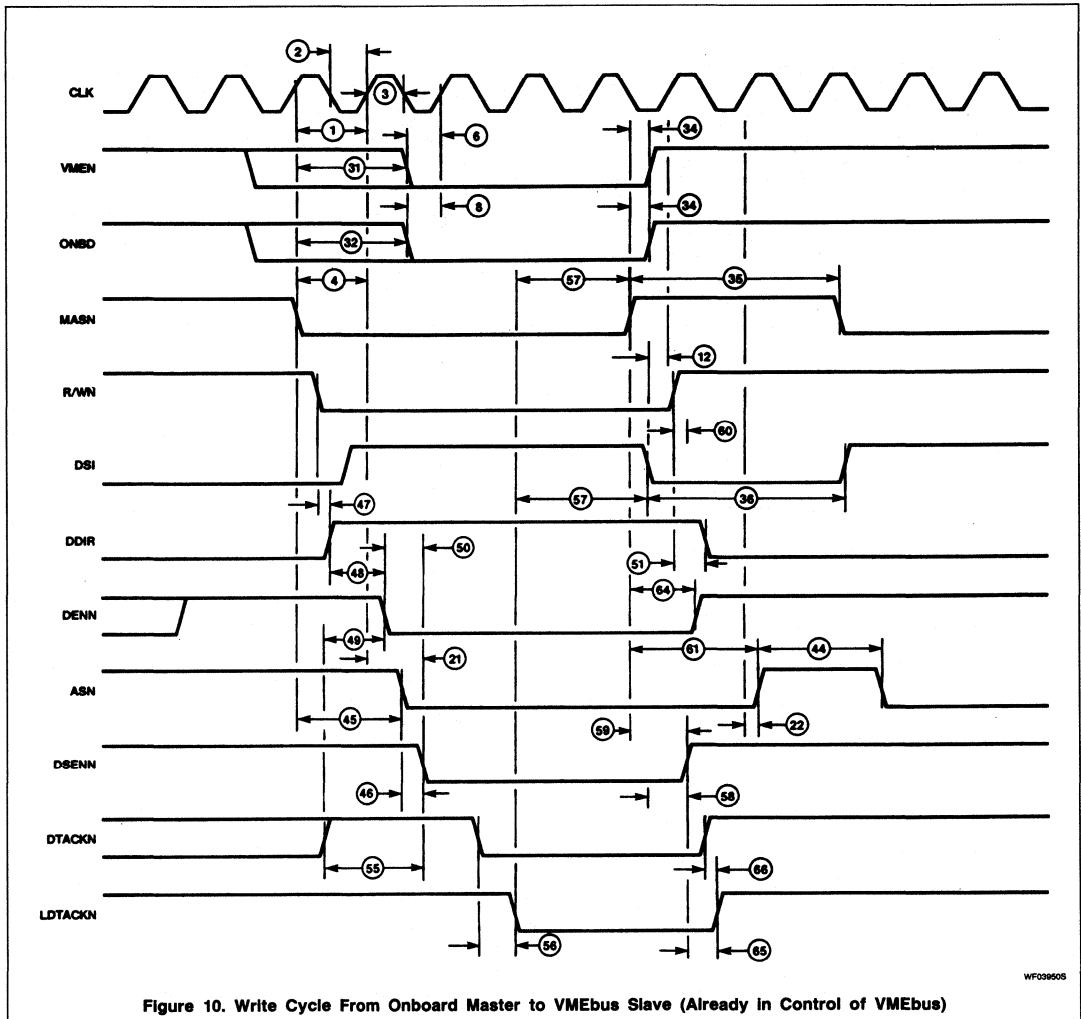

VMEbus Controller (BUSCON)

SCB68172

2

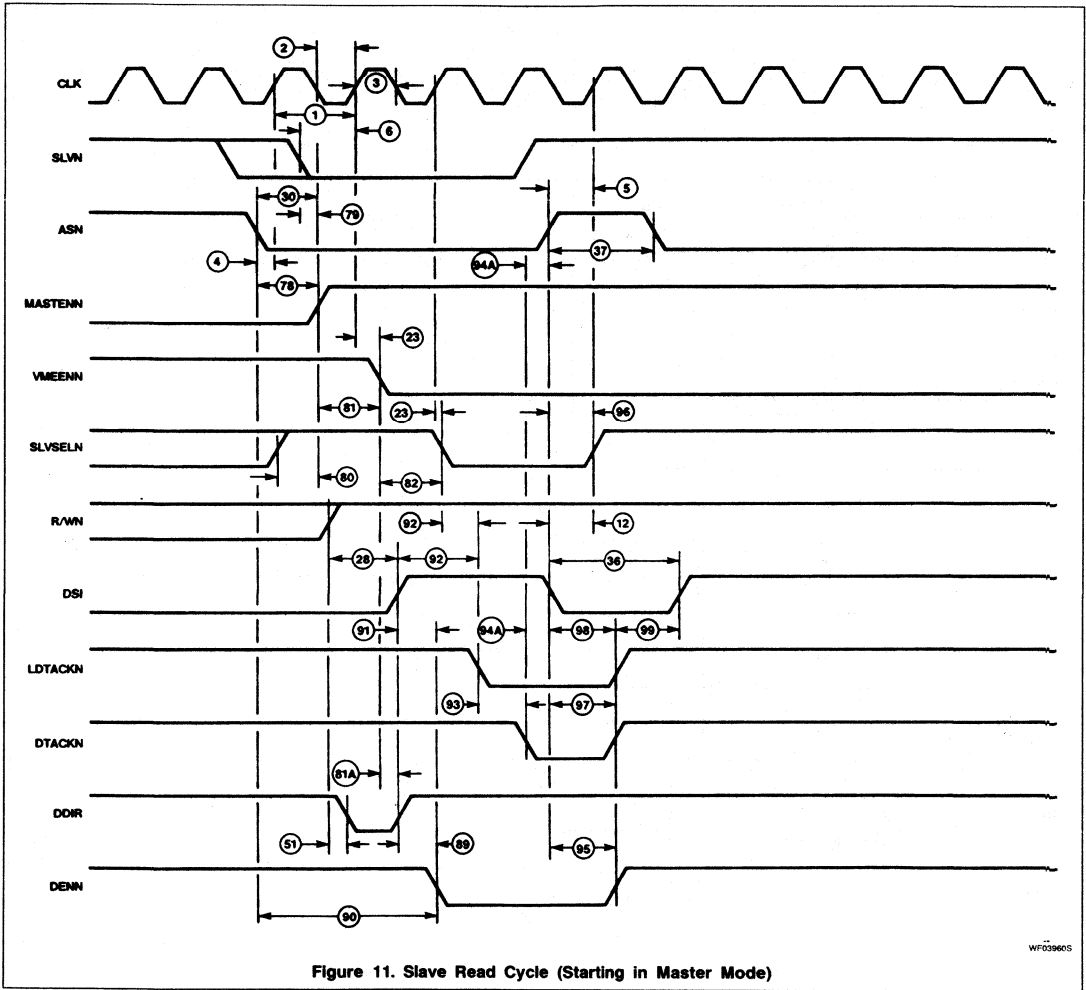

VMEbus Controller (BUSCON)

SCB68172

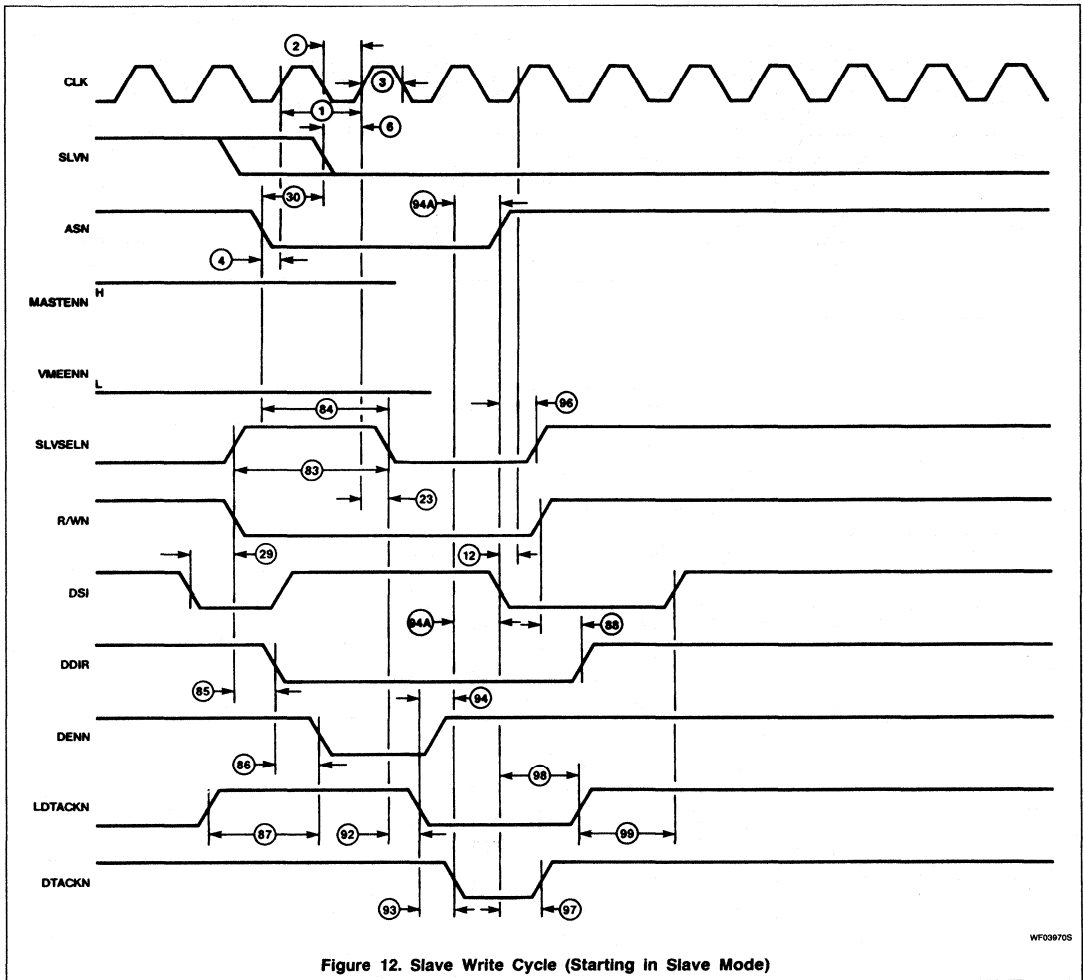

# VMEbus Controller (BUSCON)

# SCB68172

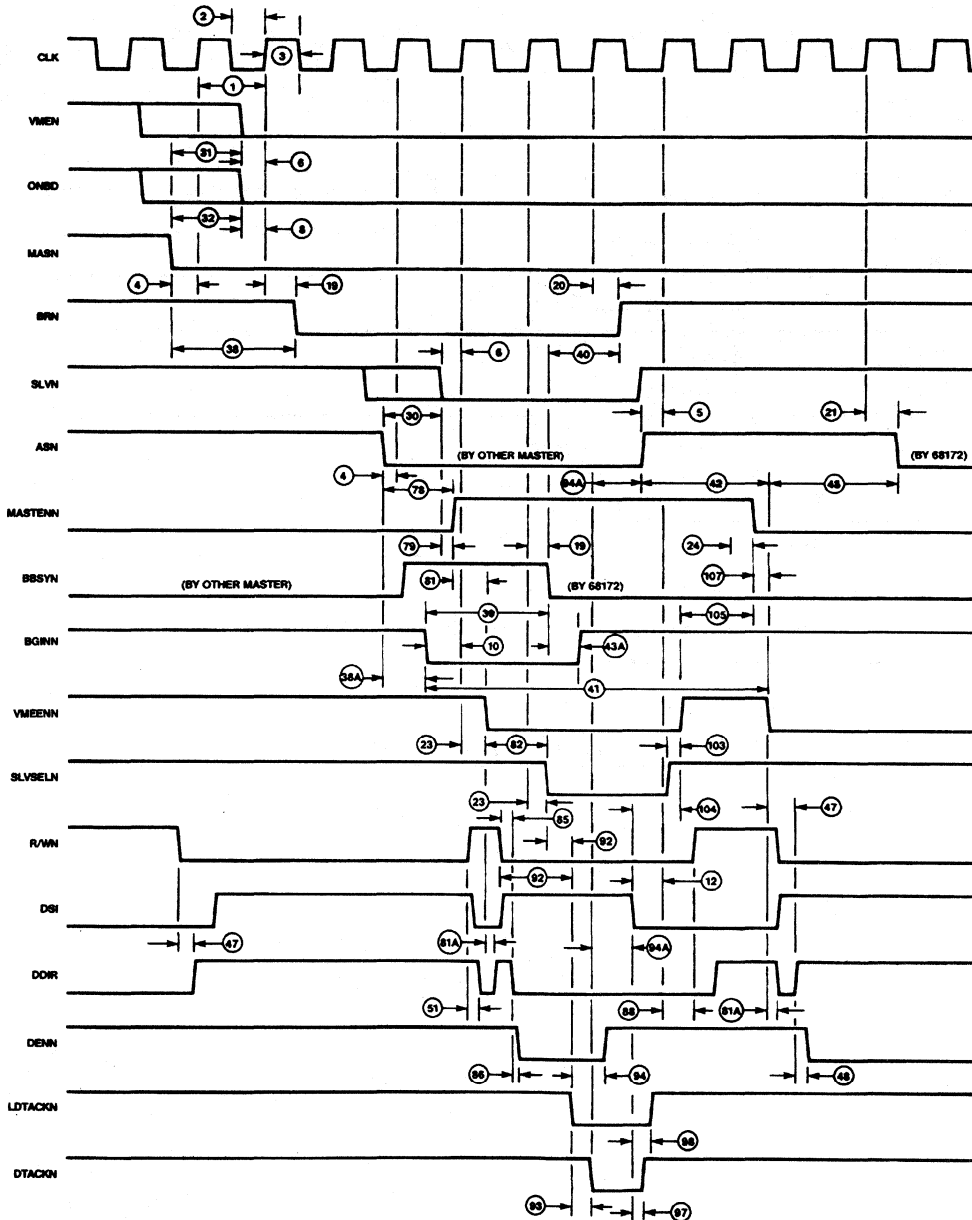
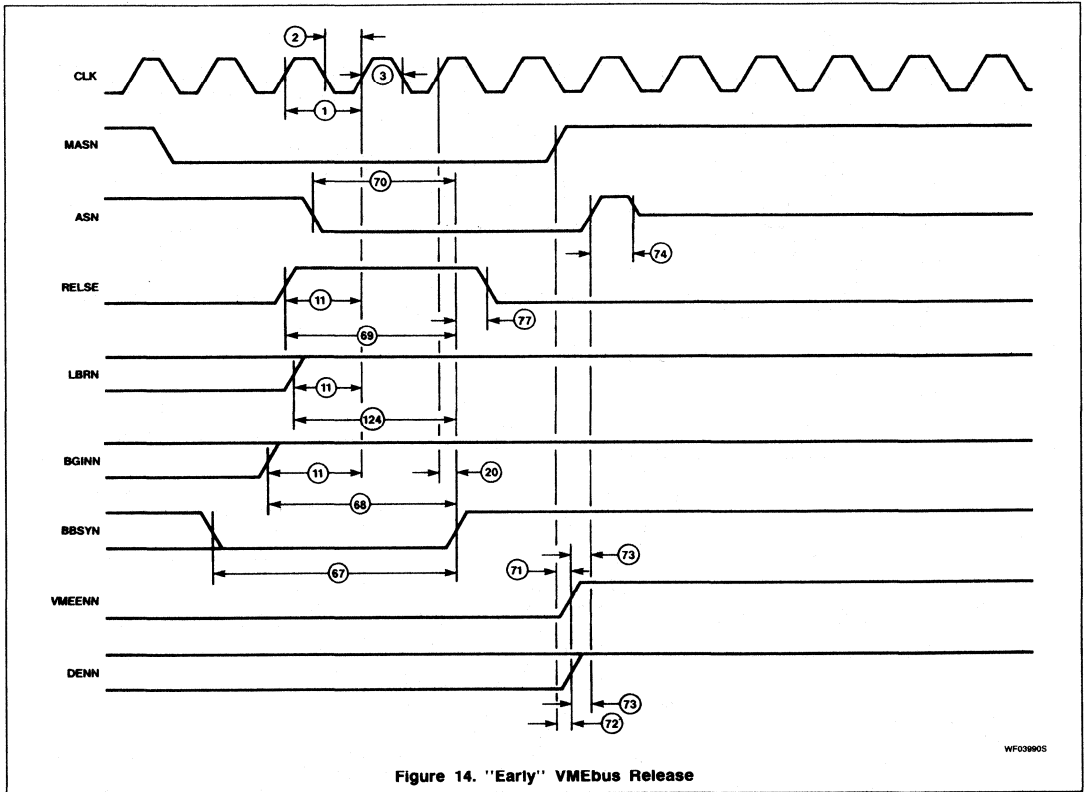

Figure 13. VMEbus Acquisition, Including Slave Write Cycle

WF039815

VMEbus Controller (BUSCON)

SCB68172





VMEbus Controller (BUSCON)

SCB68172

2

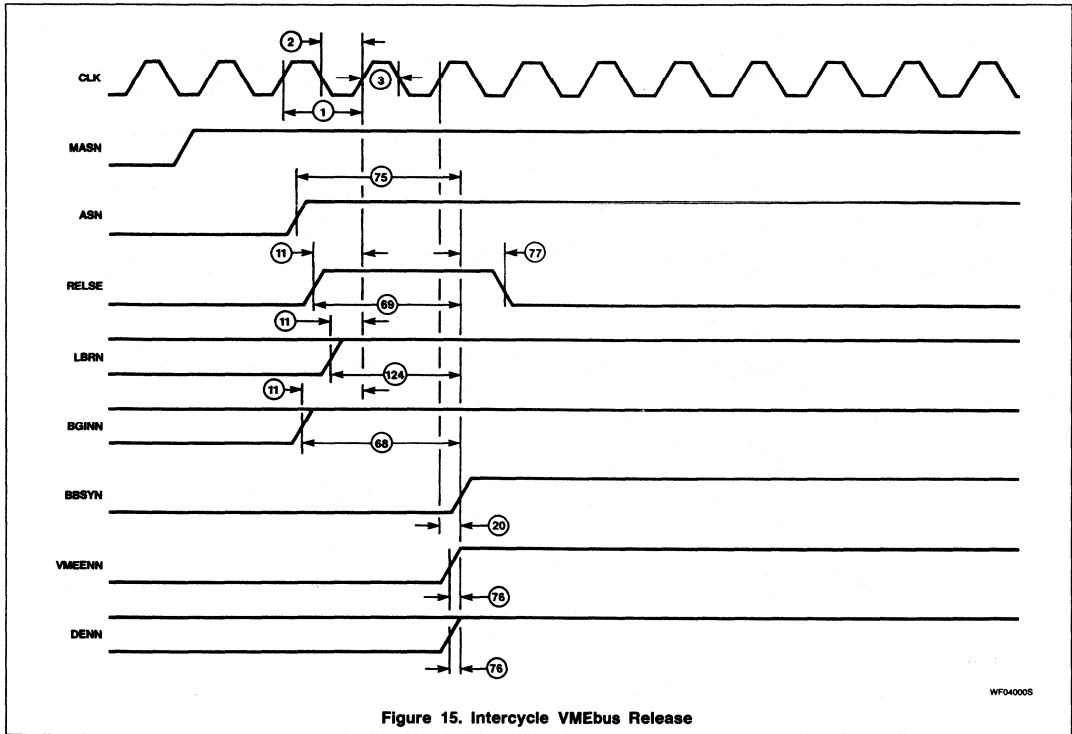

Figure 15. Intercycle VMEbus Release

WF040005

VMEbus Controller (BUSCON)

SCB68172

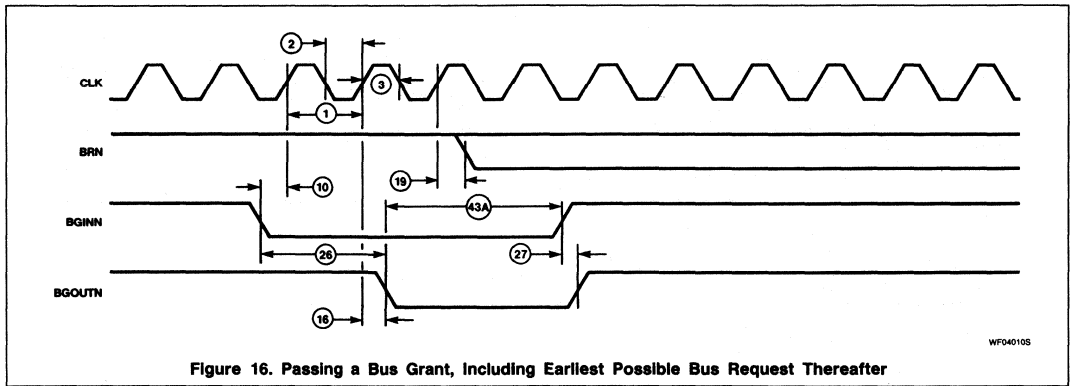

Figure 16. Passing a Bus Grant, Including Earliest Possible Bus Request Thereafter

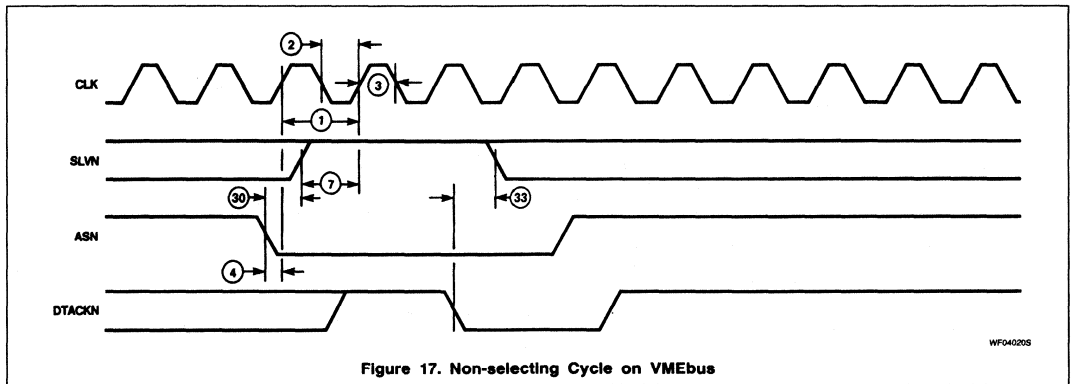
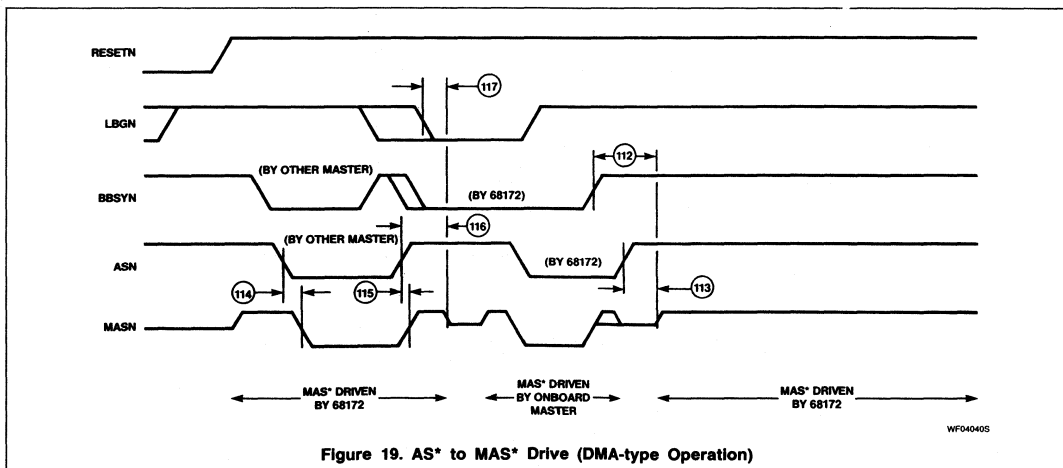
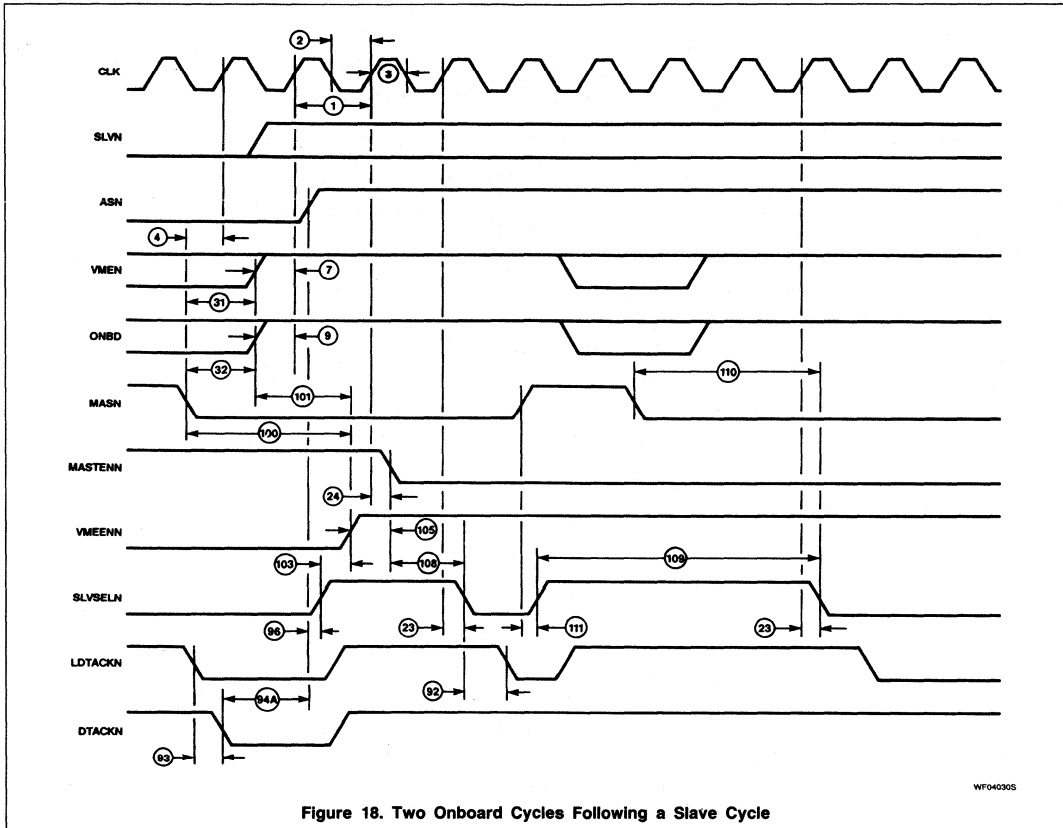

Figure 17. Non-selecting Cycle on VMEbus

VMEbus Controller (BUSCON)

SCB68172



VMEbus Controller (BUSCON)

SCB68172

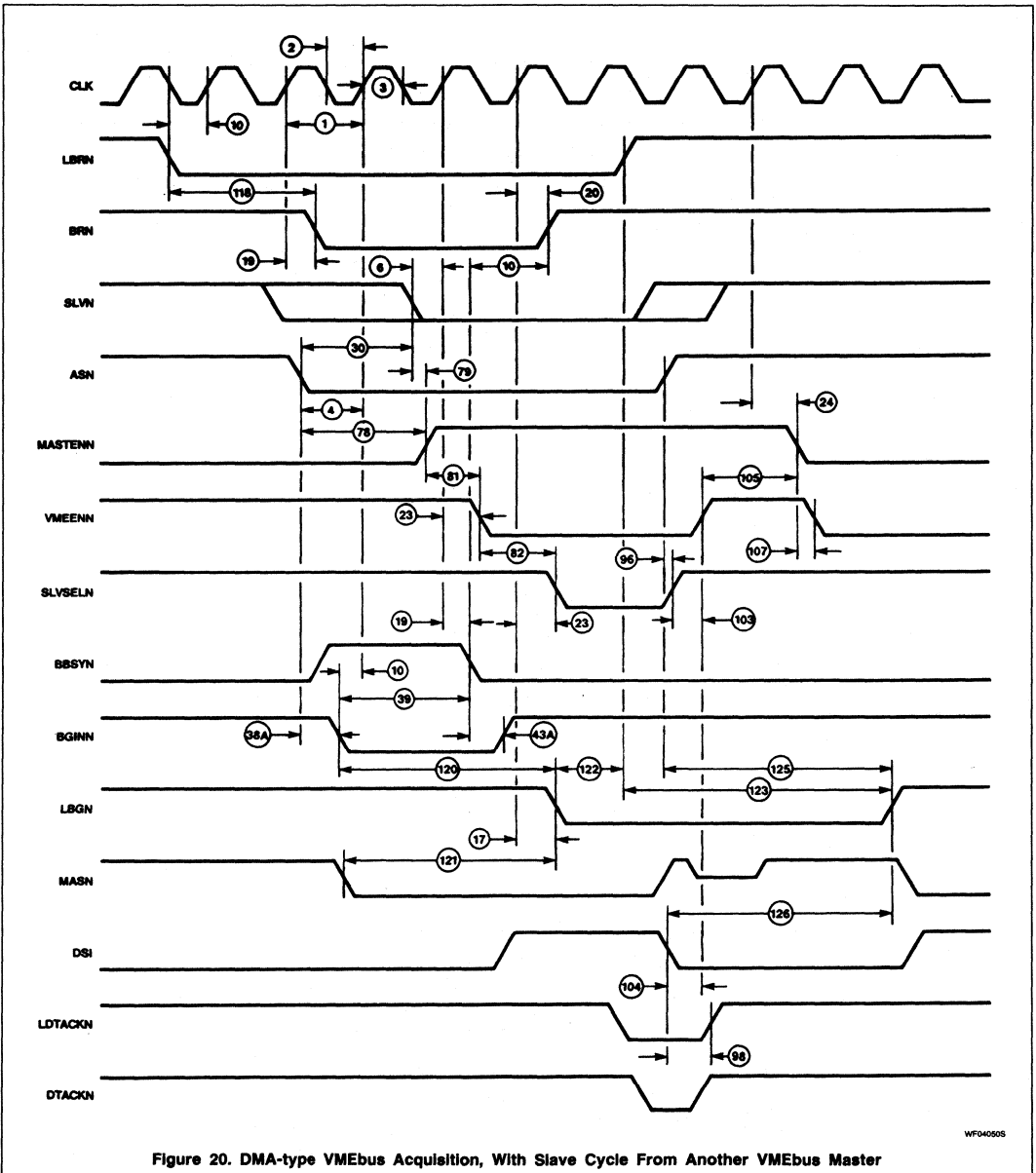
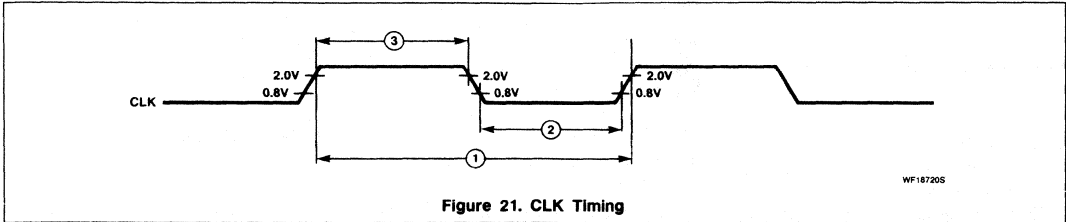

Figure 20. DMA-type VMEbus Acquisition, With Slave Cycle From Another VMEbus Master

WF040505

VMEbus Controller (BUSCON)

SCB68172



2

# SCC68173

## VMSbus Controller (VMSCON)

*Preliminary Specification*

### Microprocessor Products

#### THE VMSbus

THE VMSbus provides a secondary control and data path in the backplane of VMEbus systems, and can also be used in other backplanes and in 'intercrate' (short inter-system) applications. Providing such capabilities as message passing, generalized event/interrupt communication, discrete signal control, and synchronization/semaphore operations, the VMSbus is especially significant for multiprocessor and/or fault-tolerant systems. With a 2.9Mbit/sec data rate in a backplane environment, collision-free self-arbitration during frame transmission, and variable message priority, the VMSbus offers a high-speed, deterministic path for the guaranteed delivery of short, urgent messages.

#### SCC68173 VMSbus CONTROLLER

The Signetics SCC68173 VMSbus Controller (VMSCON) is a register-oriented peripheral device that includes a collection of the basic functional modules described in the VMSbus specification. It interfaces to the VMSbus via the SCB68171 VMSbus Interface, and to a standard 68000 family bus or other parallel data buses. The SCC68173 includes the following VMSbus functions:

#### Qty Function Functional Modules

1	Controller	Header sender plus frame monitor
1	Talker	Data sender plus header receiver
1	Listener	Data receiver plus header receiver
4	Flags	Status flip-flop plus header receiver

These functions are fully programmable so they can be used in a wide variety of combinations. The flags control two discrete output signal pins. All functions are designed to be driven via vectored interrupts.

#### FEATURES

- Header sender paired with frame monitor
- Data sender with four-byte buffer
- Data receiver with four-byte buffer
- Four programmable flag modules
- Register blocks with sequential access
- Seven maskable interrupt sources
- Pending interrupt register
- Input signal can control frame transmission
- Interrupt vector base register
- Multiplexed header receivers
- Two direct control outputs
- 68000 bus compatible
- CMOS Technology
- 600 mil package width

The SCC68173 is designed to be used with the SCB68171 which interfaces to the VMSbus clock (SERCLK) and data (SERDATN) lines. It also provides all the 68000 equivalent parallel bus controlling signals with an 8-bit bidirectional data bus. A set of command, status, and data registers are selected by the appropriate lower address bit lines.

#### PIN CONFIGURATION

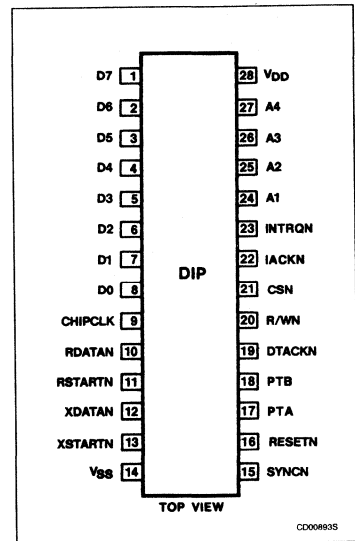

# VMSbus Controller (VMSCON)

## SCC68173

### ORDERING INFORMATION

PACKAGES	V <sub>CC</sub> = 5V ± 5%, T <sub>A</sub> = 0°C to 70°C
Ceramic	SCC68173C3I28
Plastic	SCC68173C3N28

### BLOCK DIAGRAM

The SCC68173 VMSbus Controller consists of five major sections. The serial/parallel and parallel/serial conversion block controls all the timing of incoming and outgoing frames,

does all on chip timing, and monitors the VMSbus. The header receiver block contains the programmed module addresses and incorporates the comparator logic to identify arriving S- and R-fields of a header subframe.

The register array can be loaded to control the header sender and the data sender, data receiver and bit modules.

Included in the array is a data sender buffer and a data receiver buffer. The interrupt control block provides request and acknowledge logic. The parallel bus interface includes four address lines, an 8-bit data bus, and bus control signals. There are also two direct control output lines available (PTA, PTB).

**2**

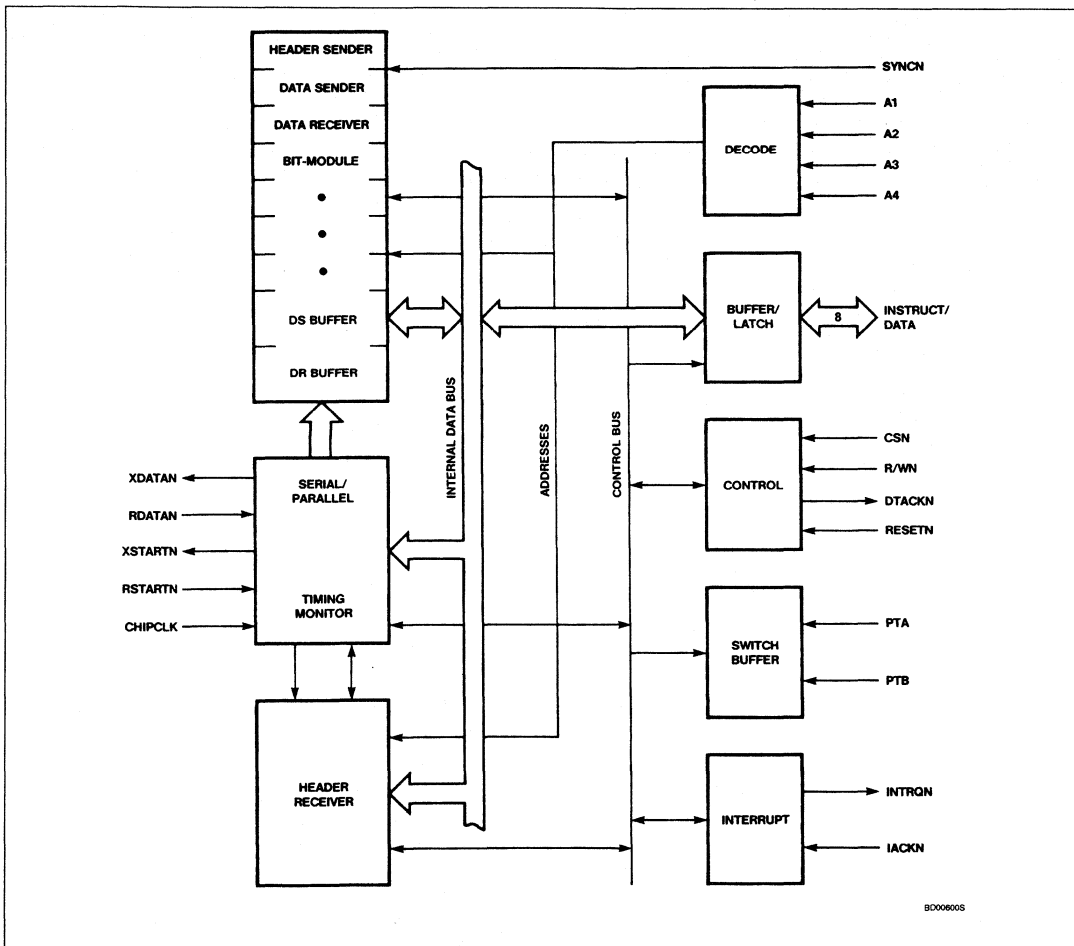

## VMSbus Controller (VMSCON)

SCC68173

**SCB68171 VMSbus INTERFACE**

The VMSbus serial clock (SERCLK) provides for well-defined sampling times called S1 and S2. The Signetics SCB68171, a high speed bipolar interface, releases the VMSbus Controller from the VMSbus timing requirements. It also serves as a buffering device for multiple onboard VMSbus Controllers and provides the high current required on the SERDATN line. Figure 1 shows the VMSbus interface and controller interconnect. A timing diagram is shown in Figure 2.

As the SCC68173 sends data or prepares to do so, it also monitors the RDATAN and RSTARTN inputs for conflict with other transmitters. The XDATAN and XSTARTN outputs provide the signal timing required by the SCB68171. As an immediate response to a detected misplaced start bit, the VMSbus controller generates XSTARTN and XDATAN low simultaneously, which makes the SCB68171 drive SERDATN low immediately, to "jam" the VMSbus.

**REGISTER BLOCKS**

The SCC68173 has four address line inputs, A4 - A1, for a total of 16 register addresses. Of these, 10 are simple 8-bit registers while the other six address values (2, 3, 5, 10, 14,

and 15) reference register blocks. Each register block has an internal address pointer that is used to access the "current" 8-bit register from among the several registers in the block. After the current register is read or written, the internal address pointer is incremented to point to the next register in the block. After the last register in a block is read or written, the pointer cycles back to the first register in the block.

The internal address registers, for blocks 2, 3, 5, and 10 are reset to the first register in the block, whenever any other register within R0 - R13 is accessed. The internal address pointers for R14 and R15 are independent, and are reset only when the DSE bit in R7 and the DRE bit in R8 (respectively) is changed.

**VMSbus OVERVIEW**

Information is transmitted in frames on the VMSbus. A frame is a sequence of consecutive bits in a prescribed arrangement or format. Figure 3 shows the three types of frames defined for the VMSbus. The first 26 bits, called the header subframe, are the same for all three frame types, and are sent by a VMSbus functional module called a header sender.

The header subframe contains two 10-bit fields called the S and R addresses. Either or both of these addresses may select one or more VMSbus functional modules called header receivers. Header receivers may be paired with other VMSbus functional modules called data senders and data receivers, and/or may control status bits (flipflops). The combined functions are called talkers, listeners, and flags, respectively.

The first frame in Figure 3 shows the case where one (or more) of the header receivers selected (by either the S or R address) is not ready for the frame. In this case, the not-ready header receiver cancels the frame by driving the value 111 in the frame type field. Such cancelled frames end immediately after the frame type field.

The second frame in Figure 3 shows a non-data frame. This type of frame results when the S address does not select a talker. In normal operation, the R address of a non-data frame does not select a listener. The frame type field contains zero and is immediately followed by the frame status field, which indicates whether flags were selected by the S and R addresses respectively, and whether there were any problems with the frame.

**PIN DESCRIPTION**

MNEMONIC	PIN NO.	TYPE	NAME AND FUNCTION
XDATAN, XSTARTN	12,13	O	<b>Transmit Data Control:</b> Open drain outputs. Set up during CLK low time as follows: XDATAN            XSTARTN H            H            Zero bit (or not transmitting a frame) L            H            One bit H            L            Start bit Also, if RSTARTN goes low during a frame (misplaced start bit), the SCC68173 drives both of these signals low during the CLK high time, which forces SERDATN low and jams the bus.
RDATAN	10	I	<b>Serial Data Input</b>
RSTARTN	11	I	<b>Start Detect Input:</b> Active low whenever a start condition is detected on the VMSbus.
CHIPCLK	9	I	<b>Clock:</b> The CLK signal is derived from SERCLK - the serial bus clock - by the bipolar interfacing device.
RESETN	16	I	<b>Reset:</b> Active low signal, which clears most of the controller's logic.
PTA, PTB	17,18	O	<b>Control:</b> These outputs are controlled by on-chip bit modules for direct control purposes.
DTACKN	19	O	<b>Data Transfer Acknowledge:</b> Open drain, active low.
CSN	21	I	<b>Chip Select:</b> This active low signal activates transfer on D0 - D7.
A1 - A4	24 - 27	I	<b>Address Lines:</b> These lower address lines select on-chip registers.
INTRQN	23	O	<b>Interrupt Request:</b> Active low, open drain output which signals the CPU that one or more of seven maskable interrupting conditions is true.
IACKN	22	I	<b>Interrupt Acknowledge:</b> Active low input indicating an interrupt acknowledge cycle.
D0 - D7	8 - 1	I/O	<b>Data Bus:</b> Bidirectional 3-State data bus used to transfer commands, data, and status.
R/WN	20	I	<b>Read/Write:</b> Read/write control.
SYNCN	15	I	<b>Synchronize:</b> Input which controls frame transmission by the header sender module.
V <sub>DD</sub>	28	I	<b>+ 5V ± 5% power input</b>
V <sub>SS</sub>	14	I	<b>Ground</b>



## VMSbus Controller (VMSCON)

SCC68173

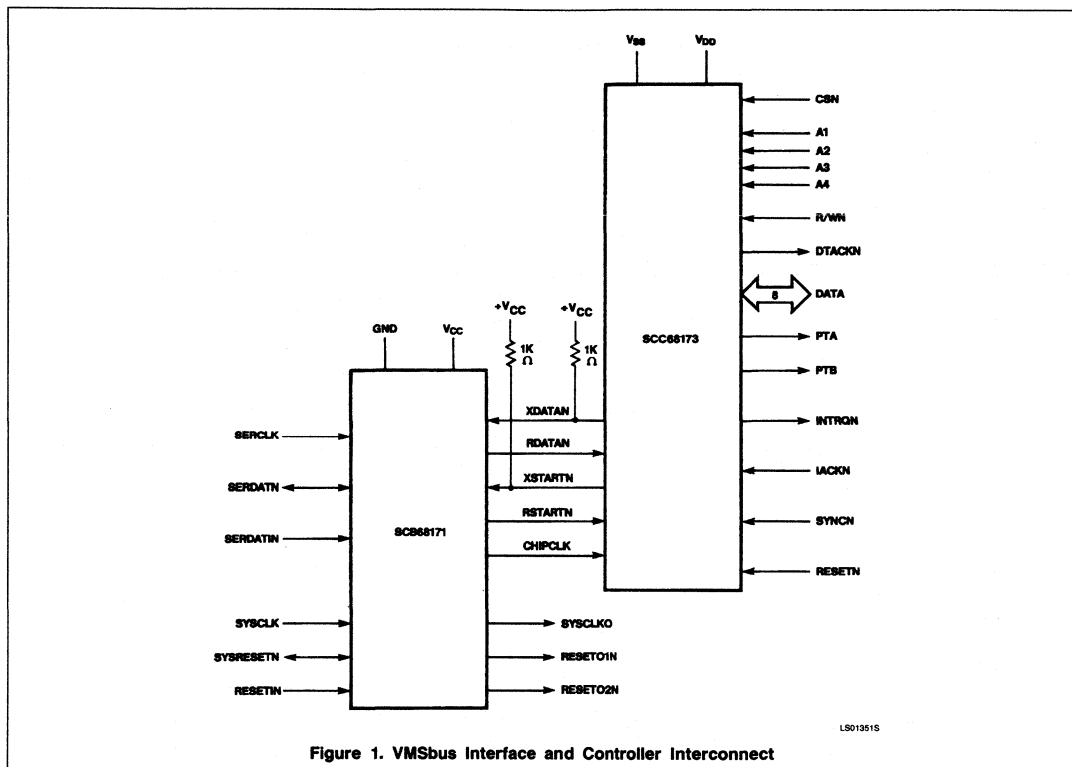

Figure 1. VMSbus Interface and Controller Interconnect

The third and last frame in Figure 3 shows a data frame. In this case, the S address selected a talker function. The data sender sends one of the values 001-110 in the frame type field, indicating the number of data bytes which follow. In normal operation, the R address selects a listener function, which receives the data. The data is then followed by the frame status field, which indicates if there were any problems with the frame.

As shown in Figure 3, every frame is followed by a single bit called a jam bit. The jam bit should always be high/zero. This forms a guard against desynchronization among various VMSbus modules, as to where frames begin and end.

All frames begin with a special unique start bit. Each frame monitor module tracks every VMSbus frame - if it detects a start bit within

a frame, it jams the VMSbus with a string of 512 low/one bits. Since the longest VMSbus frame is 287 bits, this jam sequence is sure to affect the jam bit of any frame currently in progress.

If any VMSbus module detects a jam bit low/one, it ignores the preceding frame. The jam sequence also serves to resynchronize all VMSbus modules, which wait until it is over before transmitting any more frames.

Since a VMSbus typically includes a number of header senders, there must be a way to control when they start sending frames. As already noted, frame monitor modules track the progress of every VMSbus frame. If a header sender is signaled to start a frame while its paired frame monitor is tracking a frame, it waits until the current frame is completed.

VMSbus data is wire-ORed, so that if several modules send data in the same bit time, the result is the logical OR of their data. This fact is used to provide bus arbitration as frames are sent. Whenever a module sends a zero/high bit, it also senses the result bit on the bus. If it senses a one/low, it has lost the arbitration and stops sending data. Typically, a header sender waits until the current frame is over, and then tries to send its header subframe once again.

This arbitration method ensures that data is never lost or garbled because of contention for use of the VMSbus. If several modules send data, the data with the highest binary value gets through without distortion. Arbitration is always used by header senders; its use is optional for data senders, depending on the DSAE bit in the header subframe.

## VMSbus Controller (VMSCON)

## SCC68173

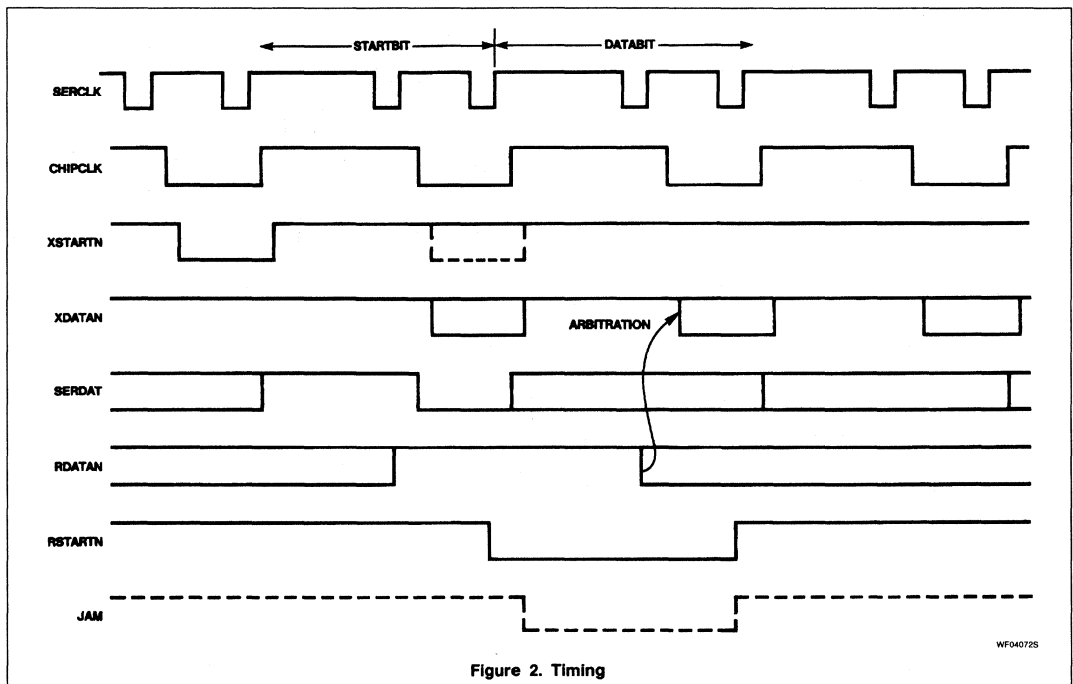

Figure 2. Timing

### CONTROLLER FUNCTION (HEADER SENDER/FRAME MONITOR)

Before a header subframe can be sent, the information in it must be programmed into the SCC68173. This includes the priority field (in register R0), the S and R addresses (register blocks R2 and R3), and the DSAE bit (in register R0).

If no automatic retries should be done in response to loss of VMSbus arbitration, the RTE bit in R0 should be written as 0. If up to 1 - 14, automatic retries should be done, then RTE should be written as 1, and the number of retries should be written into R1. If up to 15 automatic retries should be done, then RTE should be written as 1, but R1 need not be written.

If XRS in R0 is zero, then the S address is taken from register block R2 and the R address is taken from R3. If XRS is one, then the S address is taken from R3 and the R address from R2. This feature can be useful, for example, to send set and reset frames without reloading R2 and R3.

When the necessary information is loaded, the SCC68173 can be commanded to send the header subframe by software (setting the HSA bit in R0) or by its onboard hardware

(SYNCR input low after software has set the SCE bit in R0). After any current frame in progress has completed, the controller function then tries to send the header subframe. This attempt may have one of several results:

1. The Controller may lose VMSbus arbitration while trying to send the header subframe. In this case it always sets the LAB bit in R1. Its other actions depend on the RTE bit in R0 and on the retry counter which can be loaded by writing R1:
  - a. If RTE is zero, the SCC68173 clears the HSA bit in R0. Note that in any case where the SCC68173 clears the HSA bit in R0, it stops trying to send the header subframe, and the header sender becomes inactive. Also, if HS in R13 is set, then it sets HS in R12 and requests interrupt on IRQN.
  - b. If RTE is one, the SCC68173 decrements the 4-bit retry counter. If this operation does not result in a borrow, the controller function waits for the current frame to complete, and then tries to send the header subframe again.
  - c. If RTE is set, and decrementing the retry counter results in a borrow, the controller function clears the HSA bit in R0.
2. If the header sender wins the VMSbus arbitration through sending the HVAL bit

as low/one, it clears the LAB bit in R1 and stops sending. The frame monitor continues to track the resulting frame, through the final jam bit. If the jam bit is "one", the controller sets the jam bit in R1 and clears the HSA bit in R0. (Jam should be the overriding result, and should always be reported by the controller hardware. If this result does not preclude other bits in R1, at least jam should be the first thing checked by the software.)

3. The resulting frame may be cancelled. In this case the SCC68173 sets the CNC bit in R1 and clears the HSA bit in R0.
4. A non-data frame may result. In this case SCC68173 sets the SNT bit in R1, clears the DFR bit in R1, saves the frame status in R1 and clears the HSA bit in R0.
5. A data frame may result. SCC68173 action in this case is the same as for a non-data frame, except that it sets the DFR bit in R1.

In either case 4 or 5 above, software should check the DFR and frame status bits in R1 to see that the expected set of header receivers was selected and that the frame was otherwise correct. For cases 1 and 3 (lost arbitration and cancelled frame), the frame status

## VMSbus Controller (VMSCON)

SCC68173

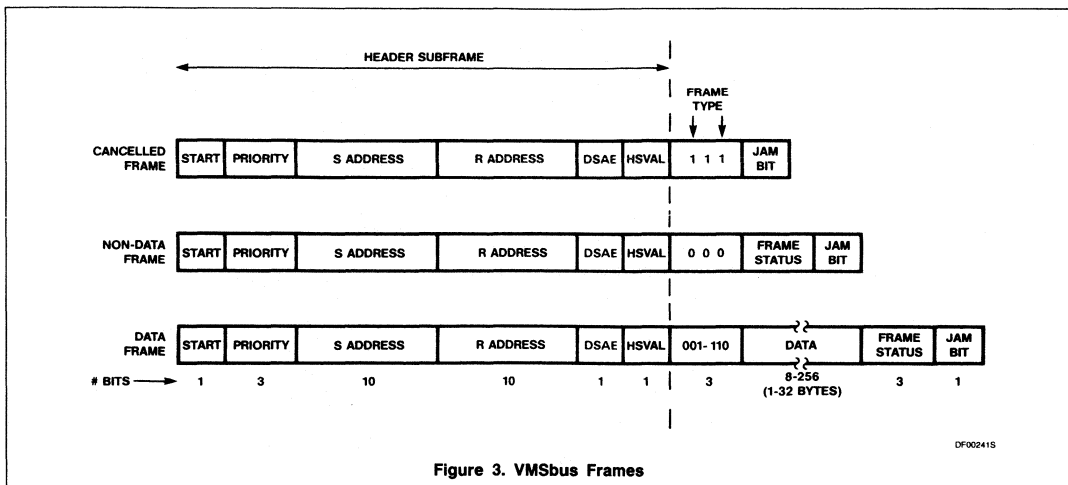

Figure 3. VMSbus Frames

DF00241S

field contains the monitored priority field from the bus, rather than the frame status field.

The priority, DSAE, XRS, and RTE bits can be set in R0 by the same command which sets HSA or SCE. When the SCC68173 clears HSA in R0, it does not clear SCE. To prevent additional transmissions in case SYNCN is still low, the SCC68173 requires that SYNCN go high again before it is enabled to start another frame.

System software can abort a series of retries by rewriting R0 with HSA cleared. It should then check HSA in R0 until it is zero, because if HSA is rewritten while a VMSbus frame is in progress, the new state does not become effective until the end of the frame.

## HEADER RECEIVERS

There are six header receivers in the SCC68173, called HR0 through HR5. Each of them can compare a 10-bit address, assigned to it by system software, to the S and R addresses in frames on the VMSbus. When an address matches, a header receiver signals its associated module that it is selected by the frame. It is important to note that header receivers and their associated modules respond identically to VMSbus frames that are initiated by their on-chip header sender, and to frames initiated by other header senders.

Addresses are assigned to header receivers by writing register block R5. The first (reset) byte in register block R5 corresponds to the less-significant 8 bits of HR0's address, while the last (12th) byte in R5 corresponds to the 2 high-order bits of HR5's address.

Note that R5 is a write-only register block. This means that if the address assigned to a particular header receiver is to be changed, all the addresses, up to and including the desired one, must be rewritten. In general this implies that system software must maintain a memory table containing the image of register block R5.

The six header receivers select specific modules in the SCC68173 as controlled by register R6. The selection coding is shown in Table 2. While each header receiver selects one module, the same address can be programmed into more than one header receiver. Each module may be selected by 0, 1, 2, or 3 header receivers.

Register R4 controls which header receivers are enabled. A module can only respond to VMSbus frames if one or more header receivers (that are enabled in R4) are programmed to select it, in R6.

A header receiver should be disabled in R4 before its selection criteria are changed in R5 and/or R6.

The six modules that are selected by the header receivers are one data sender, one data receiver, and four flags. They are described separately in the following sections. The data sender can be selected only by a match in the S address, while the data receiver can be selected only by a match in the R address. Flags can be selected by a match in either address.

## DATA SENDER

The function of this module is to send data on the VMSbus (to a data receiver module) when

it is selected by the S address in a frame. If the selected data sender is on the same board (in the same SCC68173) as the header sender that initiated the frame, the overall VMSbus operation is called a write frame. If the selected data receiver is on the same board (in the same SCC68173) as the initiating header sender, the operation is a read frame. If both the data sender and data receiver are on different boards (in different SCC68173's), the operation is called a move.

System software should set up a data sender for transmission as follows:

1. If necessary, program the address(es) for the Data Sender into one or more Header Receiver(s), by writing R5.
2. If necessary, establish the link between the Data Sender and one or more Header Receiver(s), by writing R6.
3. Enable the linked Header Receiver(s), by writing R4.
4. If necessary, enable the data sender interrupt in register R13.
5. Write the data to be sent into register block R14.
6. Write register R8 with the frame type code for 1, 2, or 4 bytes, plus the DSE bit and optionally the DSM bit (see the discussion that follows on writing R8).
7. For a write frame, program the header sender to initiate a frame with the data sender's address in the S field.

Because the DSE bit in R8 can be set and cleared by system software and also cleared by a VMSbus frame, a special technique must be used by system software in writing R8. For bits DSE, DSM, and DST, writing a '1' in each bit position indicates that the bit should be

## VMSbus Controller (VMSCON)

SCC68173

Table 1. Registers

Header sender control and monitor	R0	R/W	Priority			DSAE	XRS	RTE	SCE	HSA
	R1	R	SNT	CNC	LAB	JAM	DFR	Priority/Status		
		W	Reserved				Preset retry cntr			
	R2*	R/W	S-FIELD						LSB	
			Not Used						MSB	
R3*	R/W	R-FIELD						LSB		
		Not Used						MSB		
Module addressing	R4	R/W	Reserved	Reserved	HR5	HR4	HR3	HR2	HR1	HR0
	R5*	W	HR0 address						LSB	
			Not Used						MSB	
			HR1-5 addresses							
R6	R/W	Header receiver mux								
Module control	R7	R/W	Write Data	DRE	DRM	DRV	DRA	DR frame type		
	R8	R/W	Write Data	DSE	DSM	DST	Write Enable	DS frame type		
				Write select						
	R9	R/W	Write Data	Reserved			FF3	FF2	FF1	FF0
	R10*	R/W	Connect FF1	FF1 mode			Connect FF0	FF0 mode		
Connect FF3			FF3 mode			Connect FF2	FF2 mode			
Interrupt control	R11	R/W	Interrupt vector (lower 3 bits read only)							
	R12	R/W	INP	HS	DR	DS	FF3	FF2	FF1	FF0
	R13	R/W	INE	HS	DR	DS	FF3	FF2	FF1	FF0
Buffers	R14*	R/W	Data sender buffer							
	R15*	R	Data receiver buffer							

**NOTE:**

\*Indicates sequentially-accessed register block.

written with the data (0 or 1) contained in the high-order bit (labeled Write Data in Table 1). Also, the data sender frame type bits are written from the three least significant bits only if the next more significant bit is a '1' (labeled Write Enable in Table 1).

When the data sender is selected by the S address in a header subframe, it begins operation by sending a code in the frame type field which directly follows the header subframe. If bit DSE in register R8 is zero, indicating that system software has not set up current data and enabled the data sender, it sends 111 in the frame type field, cancelling the frame.

If DSE in R8 is one, the data sender sends one of the values 001, 010, or 011 in the frame type field, as controlled by the low order bits in R8. These values indicate 1, 2, or 4 bytes of data, respectively, following the frame type field. (If one of the illegal values 000, 100 - 111, is inadvertently programmed into the three low-order bits of R8, the SCC68173 sends 111 in the frame type, cancelling the frame.)

While sending the frame type, the data sender uses VMSbus arbitration as described previously in VMSbus Overview. If it loses the arbitration, it stops sending and captures the winning frame type value. If the value is 111, another module (typically the data receiver) is not ready for the frame and has cancelled it.

In this case the data sender ignores the frame, keeping DSE set.

If the data sender loses the arbitration to a frame type value 010 - 110, then another data sender is also selected by the S address, and it is set up to send more data than is this data sender. In this case, this data sender waits out the number of bits indicated by the winning frame type value, and then sends the error code 110 in the frame status field.

If the data sender wins the VMSbus arbitration in the frame type field, it goes on to send 1, 2, or 4 bytes of data from register block R14. If the DSAE bit in the initiating header subframe was 1, it uses VMSbus arbitration

## VMSbus Controller (VMSCON)

SCC68173

while sending the data, and if it loses the arbitration it ignores the frame, leaving DSE set. If DSAE was 0, it does not use VMSbus arbitration, but simply places each data bit on the VMSbus.

After the data, the data sender sends the code 010 in the frame status. This OR's with the code 001 from the data receiver to make the "success" code 011.

The data sender also samples the frame status and the following jam bit. If the status code is 011 and the jam bit is 0, then it sets the DST bit in register R8. Also, if the DSM bit in R8 is zero, it clears the DSE bit in R8 and, if the INE and DS bits in R13 are both one, it requests interrupt on IRQN. If DSM is one, the SCC68173 leaves DSE set and does not request interrupt (regardless of INE and DS in R13).

The DSM bit in R8 thus controls the gross operational state of the data sender. When DSM is zero, setting DSE enables the module to send data once, then clear DSE and cancel any further frames that select it, until system software (loads new data and) sets DSE again. When DSM is one, setting DSE enables the data sender to send the data in register block R14 as many times as it is selected by VMSbus frames, until system software clears DSE.

Software cannot access register block R14 while DSE is set. This restriction applies to both reading and writing, and can be handled in one of three ways:

1. Wait until DSE is cleared by the SCC68173. This is normal operation with DSM zero, but is not applicable if DSM is one.
2. Rewrite R8 to make DSE zero. Software should then check R8 until DSE reads back as zero, because if the data sender is selected by the current VMSbus frame, the clearing of DSE does not become effective until the end of the frame.
3. Simply go ahead and access register block R14. This automatically clears DSE, but the entire access operation is delayed if the data sender is selected by the current VMSbus frame, until the end of the frame. Systems which cannot tolerate a DTACKN delay of up to 270 bit times should use method 2 above. (Since SCC68173 data senders are restricted to 1 - 4 byte data, the practical maximum delay is about 40 bit times except in the case where there is a data size conflict between a SCC68173 and some other kind of VMSbus data sender. 40 bit times is about 14µsec at a 2.9MHz data rate.)

Table 2. Header Receiver Multiplexing in Register A6

A6 BITS	HR	VALUE	MODULE SELECTED	BY MATCH IN
7 (MSB)	3	0	Bit module FF3	S, R
		1	Data receiver	R
6	5	0	Data receiver	R
		1	Bit module FF2	S, R
5, 4	2	00	Bit module FF2	S, R
		01	Bit module FF1	S, R
		10	Data receiver	R
3, 2	1	11	Bit module FF2	S, R
		00	Bit module FF1	S, R
		01	Data sender	S
		10	Bit module FF2	S, R
1	4	11	Bit module FF1	S, R
		0	Data sender	S
		1	Bit module FF1	S, R
0 (LSB)	0	0	Bit module FF0	S, R
		1	Data sender	S

## DATA RECEIVER

A data receiver captures data from VMSbus frames in which it is selected by the R address. System software should set up a data receiver as follows:

1. If necessary, program the address(es) for the Data Receivers into one or more Header Receiver(s), by writing R5.
2. If necessary, establish the link between the Data Receivers and one or more Header Receiver(s), by writing R6.
3. Enable the linked Header Receiver(s), by writing R4.
4. If necessary, enable the DR interrupt in register R13.
5. Write register R7 with DRE one, and optionally, DRM one.
6. For a read frame, program the header sender to initiate a frame with the data receiver's address in the R field.

Because the DRE and DRA bits in R7 can be set and cleared by system software and also cleared by a VMSbus frame, a special technique must be used by system software in writing R7. For bits DRE, DRM, DRV, and DRA, a '1' in that bit position indicates that the bit should be written with the data contained in the high-order bit (labeled Write Data, in Table 1).

When the data receiver is selected by the R address in a header subframe, it clears the DRA bit in R7. If bit DRE in R7 is zero, it sends 111 in the frame type field that follows the header subframe, thereby cancelling the frame.

If DRE in R7 is one, the data receiver samples the frame type field and saves the result in the low-order 3 bits of R7. If the frame type is 111, the frame has been cancelled by another VMSbus module (typically a data sender). In this case the data receiver ignores the frame.

If the frame type field is 000, the data receiver then sends the error code 101 in the immediately following frame status field.

If the frame type field is 100, 101, or 110, the data receiver waits for 64, 128, or 256 bits of data (respectively) to go by, and then sends the error code 101 in the frame status field.

If the frame type field is 001, 010, or 011, the data receiver captures the following 1, 2, or 4 data bytes (respectively), and saves them in register block R15. It then sends the frame status code 001, which OR's with the code 010 from the data sender to produce the "successful" status code 011.

The data receiver also samples the frame status and the following jam bit. If the status code is 011 and the jam bit is 0, then it sets the DRV bit in R7. Also, if the DRM bit in R7 is zero, the data receiver clears the DRE bit in R7 and, if the INE and DR bits in R13 are both one, it requests interrupt on the IRQN pin. If DRM is one, it leaves DRE set and does not request interrupt, regardless of INE and DR in R13.

Thus the DRM bit governs the gross operational mode of the data receiver. If DRM is zero, once the data receiver has successfully received data, it clears DRE and cancels any further frames addressed to it, until system software (reads the data from R15 and) sets DRE again. When DRM is one, the data receiver will accept data into R15 from any frame addressed to it.

When DRM is one, system software must guard against the possibility that a new VMSbus frame could be received while it is reading data out of register block R15, which would result in reading out a mixture of old and new data. It can do this in one of two ways:

1. Rewrite R7 with DRE zero. Software should then check R7 until DRE reads

## VMSbus Controller (VMSCON)

SCC68173

Table 3. Operating Modes for Flags in A10

VALUE	MODULE TYPE	INTERRUPT ON
000	Disabled (Cancellation)	
001	Simple flag	Toggle
010	Simple flag	Set
011	Simple flag	Clear
100	Semaphore	Set
101	Semaphore	Clear
110	Token	Set
111	Token	Clear

Table 4

FF1 TO PTA OR FF3 TO PTB	FF0 TO PTA OR FF2 TO PTB	FF1 OR FF3	FF0 OR FF2	PTA OR PTB
0	0	X	X	Low
0	1	X	0	Low
0	1	X	1	High
1	0	0	X	Low
1	0	1	X	High
1	1	0	0	Low
1	1	0	1	High
1	1	1	0	High
1	1	1	1	High

back as zero, because if the data receiver is selected by the current VMSbus frame, the clearing of DRE does not become effective until the end of the frame. When DRE is zero, the software can safely read out register block R15. Typically, it then sets DRE again. This method has the disadvantage that it results in cancellation of any frame which selects the data receiver while its data is being read out.

- Set the DRA bit in register R7, read out register block R15, then read R7. If the DRA bit in R7 is still set, the data from R15 and the frame type code in R7 are valid. If DRA has been cleared (by the SCC68173 because it started receiving a frame), then the software should set DRA and try again.

## FLAGS

Flags essentially implement a flip-flop or latch which is set when the module is selected by the S address in a frame, and reset when the module is selected by the R address in a frame. Four flags are provided in the SCC68173, called FF0 through FF3. These modules can also be directly controlled by system software, and can be programmed to control two discrete SCC68173 output pins, PTA and PTB.

Register R9 provides direct sensing and control of the state of the flags. Since the state of the modules can be changed both by system software and by VMSbus frames, a special technique must be used in writing R9. A '1' in any or all of the four least significant bit positions indicates that a flag should be

written with the data contained in the high-order bit (labeled Write Data in table 1).

Register block R10 provides control of the operation of each flag. In R10, there are four bits for each module, of which the high-order bit determines whether the module is connected to the PTA or PTB pin, and the three less significant bits determine the module's operational mode, as shown in Table 3.

If a flag is programmed with the 000 code and is also connected to a header receiver (in R6) that is enabled (in R4), then any frame that selects the flag (in either the S or R fields) will be cancelled.

The simple flag, semaphore, and token categories also refer to circumstances where flags cancel frames that are addressed to them.

A simple flag does not cancel frames based on its state. That is, it accepts "set frames" even if it is already set, and accepts "reset frames" if it is already reset. On the other hand, if the module's interrupt was enabled (in R13) at the time of a previous frame, and the interrupt is still pending, then any frame that selects the flag (in either the S or R fields) will be cancelled.

A semaphore module cancels a set frame if it is already set, but accepts a reset frame if it is already reset. It does not cancel frames based on its pending interrupt status.

A token module cancels a set frame if it is already set, and cancels a reset frame if it is already reset. It does not cancel frames based on its pending interrupt status.

Within each category there is a choice as to when the module requests interrupt. This

choice is significant only if the module's interrupt enable bit is set in R13. System software should set up a flag as follows:

- If necessary, disable the associated header receiver(s) in R4.
- If necessary, program the initial state of the module, in R9.
- Program the module's operating mode, in R10.
- If necessary, clear any pending interrupt for the module, in R12.
- If necessary, enable interrupt for the module, in R13.
- Program the module's address via R5.
- Connect a header receiver to the module, in R6.
- Enable the header receiver in R4.

The PTA and PTB pins are high-active, and go low on reset. Each pin can reflect the state of 1 or 2 flags; as shown in Table 4.

## INTERRUPTS

As described in the previous sections, the SCC68173 can be set up to generate an interrupt request based on any of seven events:

- When the header sender finishes sending a header subframe, and clears HSA.
- When the data sender sends data in a frame, and clears DSE.
- When the data receiver receives data in a frame, and clears DRE.
- 4-7. When flag FF0-FF3 is set and/or reset by a frame.

Each of these seven potential interrupt sources is conditioned on a corresponding bit in register R13. When an R13 bit is one, the corresponding module's interrupt is enabled. The most significant bit in R13, INE, controls the overall interrupt enable of the SCC68173.

Register R12 contains a corresponding set of interrupt pending bits. An interrupt pending bit is set if the appropriate VMSbus event occurs, and the module's interrupt enable bit is one in R13. The most significant bit of R12 is the OR of the other seven bits.

A pending bit in R12 can be directly reset by writing a 1 to it. Disabling an interrupt channel in R13 automatically resets the corresponding pending bit. When an interrupt service routine processes a SCC68173 interrupt, it should clear one or more of the pending bits and/or enable bits and/or make INE zero before dismissing the interrupt, to prevent a second interrupt resulting from the same event.

When the SCC68173 detects an interrupt acknowledge cycle (IACKN low) and it is

## VMSbus Controller (VMSCON)

SCC68173

requesting interrupt on IRQN (or is about to do so), it responds by placing an interrupt vector on the D7-D0 lines and asserting DTACKN. Typically, this vector has its high-order 5 bits taken from register R11, and its low-order 3 bits in accordance with the highest-priority pending interrupt:

110	Header sender (highest priority)
101	Data receiver
100	Data sender
011	Flag FF3
010	Flag FF2
001	Flag FF1
000	Flag FF0 (lowest priority)

The exception to this vector structure is where R11 has not been programmed since the SCC68173 was reset. In this case, the

vector hexadecimal 0F is returned regardless of which modules have interrupt pending.

**Jam Sequence**

As described in VMSbus Overview, the SCC68173 monitors the VMSbus at all times (other than when RESETN is low), tracking the entire length of each frame and checking for start bits within each frame. If such a start bit is detected, it means that this SCC68173 is out of frame synchronization with one or more other VMSbus devices. In this case, this SCC68173 must send a string of 512 one bits to resynchronize the VMSbus, starting with the bit after the misplaced start bit. The timing of the SCC68173/SCB68171 interface does not allow this to be done in the normal (synchronous finite-state machine) way. Instead, if RSTARTN goes low from the SCB68171 during a frame, this signal makes

the SCC68173 produce XSTARTN and XDATAN low combinatorially. This combination makes the SCB68171 asynchronously drive SERDATN low for a one-bit. By the next bit time, the SCC68173 is set up to send the rest of the jam sequence in the normal way. A jam sequence maintains all SCC68173 hardware as it was at the start of the frame.

**Reset**

A low on the RESETN input clears the following bits to zero:

HSA and SCE in register R0

DRE and DRV in R7

DSE and DST in R8

All bits in registers R1, R4, R6, R12, R13

It also sets register R11, the interrupt vector, to the value hexadecimal 0F.

**ABSOLUTE MAXIMUM RATINGS**

SYMBOL	PARAMETER	MIN	MAX	UNIT	CONDITIONS
$V_{CC}$	DC supply voltage	-0.5	+7	V	
$\pm I_O$	DC output source or sink current - standard outputs		25	mA	for $-0.5V < V_O < V_{CC} + 0.5V$
$\pm I_{CC}; \pm I_{GND}$	DC $V_{CC}$ or GND current for types with: - standard outputs		50	mA	

**OPERATING CONDITIONS**

SYMBOL	PARAMETER	MIN	TYP	MAX	UNIT
$V_{CC}$	DC supply voltage	4.5	5	5.5	V
$V_I$	DC input voltage	0		$V_{CC}$	V
$V_O$	DC output voltage	0		$V_{CC}$	V
$T_{amb}$	Operating ambient temperature range	0		70	°C

## VMSbus Controller (VMSCON)

SCC68173

## DC ELECTRICAL CHARACTERISTICS

SYMBOL	PARAMETER	T <sub>amb</sub> (°C)					UNIT	TEST CONDITIONS		
		74HCT						V <sub>CC</sub> V	V <sub>I</sub>	Other
		+ 25			- 40 to + 85					
		Min	Typ	Max	Min	Max				
V <sub>IH</sub>	High level input voltage	2.0	1.6		2.0		V	4.5 to 5.5		
V <sub>IL</sub>	Low level input voltage		1.2	0.8		0.8	V	4.5 to 5.5		
V <sub>OH</sub>	High level output voltage standard outputs	3.98	4.32		3.84		V	4.5	V <sub>IH</sub> or V <sub>IL</sub>	-I <sub>O</sub> = 4.0mA
V <sub>OL</sub>	Low level output voltage standard outputs		0.15	0.26		0.33	V	4.5	V <sub>IH</sub> or V <sub>IL</sub>	I <sub>O</sub> = 4.0mA

## AC ELECTRICAL CHARACTERISTICS

NO.	CHARACTERISTIC	Tentative MIN	Tentative MAX	Tentative UNIT
1	A1-4 setup time to CSN low	0		ns
2	A1-4 hold time from DTACKN low	100		ns
3	RWN setup time to CSN low	0		ns
4	RWN hold time from CSN high	0		ns
5	DTACKN low to CSN high	0		ns
6	CSN high	100		ns
7	Read data valid to DTACKN low	0		ns
8	Read data to float from CSN high	0	100	ns
9	Write data setup time	0		ns
10	Write data hold time from DTACKN low	25		ns
11	CSN low to DTACKN low	100 + 2 × <sup>(15)</sup>		ns
12	DTACKN fall time		25	ns
13	CSN high to DTACKN high	0		ns
14	DTACKN low to PTA, PTB valid		100	ns
15	CLK period	320		ns
16	CLK high time	200		ns
17	CLK low time	100		ns
18	CLK rise time		6	ns
19	CLK fall time		6	ns
20	CLK high to XSTARTN low		150	ns
21	CLK low to XSTARTN off	5	50	ns
22	CLK low to XDATAN low		90	ns
23	CLK high to XDATAN off	5	80	ns
24	RSTARTN low to CLK high		-30	ns
25	RSTARTN hold time from CLK low	50		ns
26	RSTARTN high to CLK high	0		ns
27	RDATAN valid to CLK low		0	ns
28	RDATAN hold time from CLK high	100		ns
29	Misplaced RSTARTN low to XSTARTN low		100	ns
30	Misplaced RSTARTN low to XDATAN low		100	ns
31	RESETN low time	10 × <sup>(15)</sup>		ns
32	INTRQN high to DTACK low	0		ns
33	Read data valid to DTACKN low	0		ns
34	Read data to float from IACKN high	0	100	ns
35	IACKN high to DTACKN high	0	100	ns
36	SYNCRN pulse low time	100		ns
37	Frame end to INTREQN low		100 + <sup>(15)</sup>	
38	Frame end to PTA, PTB valid		100 + 2 × <sup>(15)</sup>	



# VMSbus Controller (VMSCON)

SCC68173

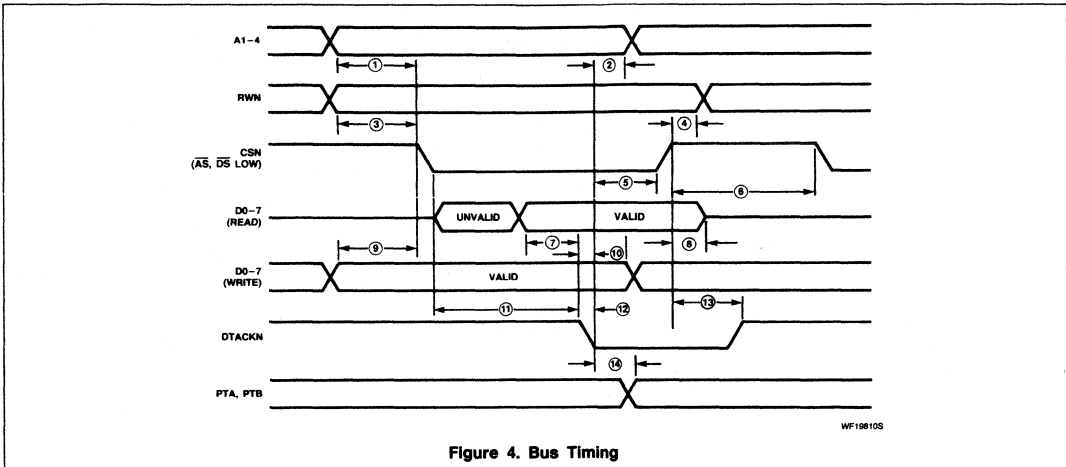

Figure 4. Bus Timing

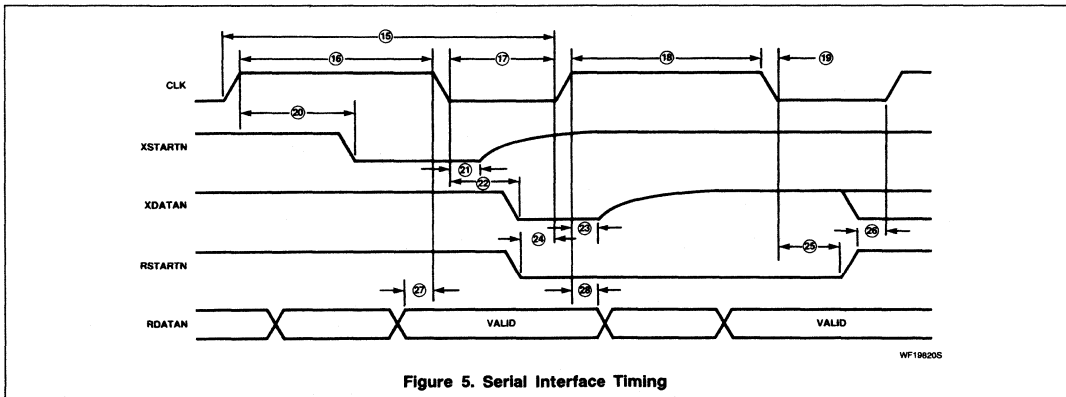

Figure 5. Serial Interface Timing

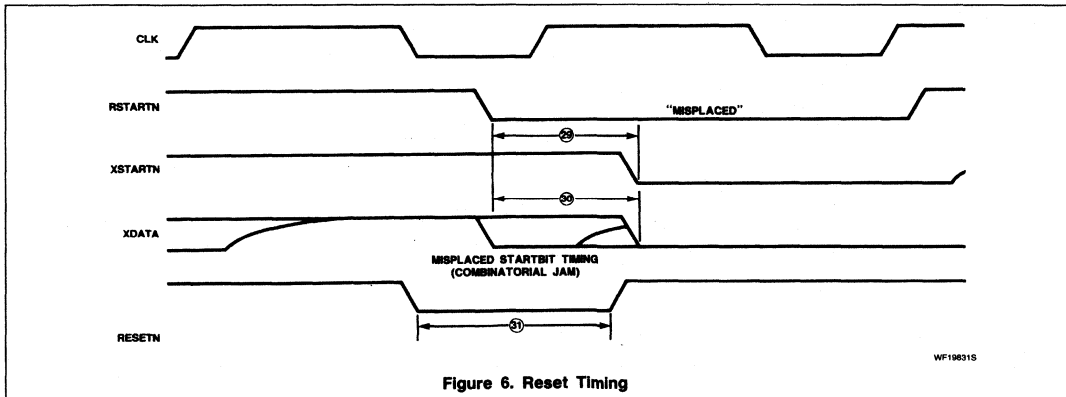

Figure 6. Reset Timing

# VMSbus Controller (VMSCON)

SCC68173

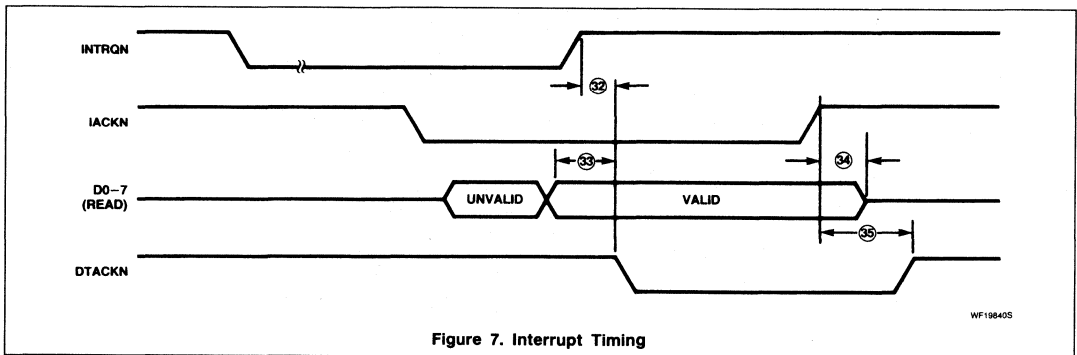

Figure 7. Interrupt Timing

WF198405

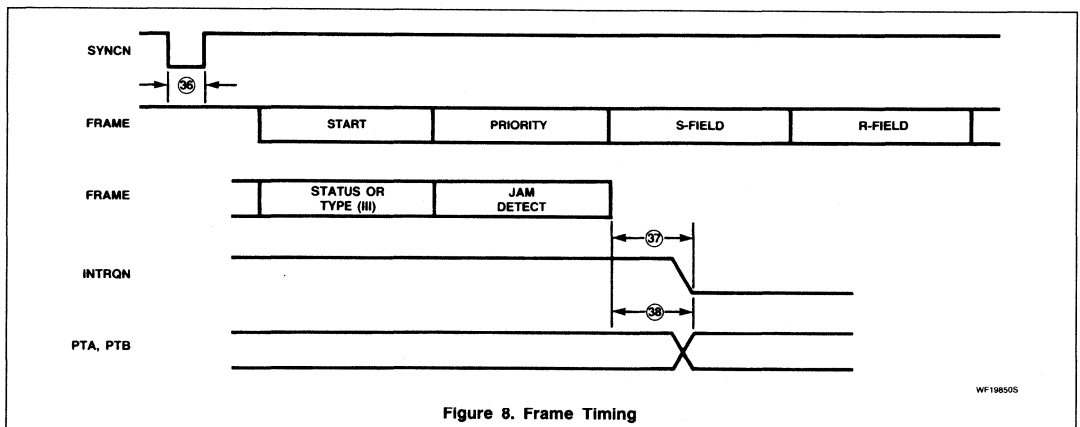

Figure 8. Frame Timing

WF198505

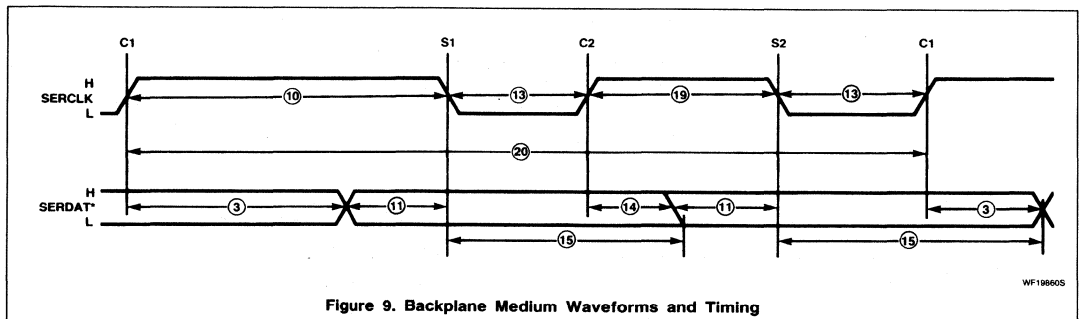

Figure 9. Backplane Medium Waveforms and Timing

WF198605

## VMSbus Controller (VMSCON)

SCC68173

**2**

## Timing RULES for Single-Subrack CLOCK SOURCE+BRIDGE Group (Figure 9)

DESCRIPTION	CONDITIONS	MIN	NOM	MAX
<b>10. Rule 7.5:</b>				
A CLOCK SOURCE + BRIDGE group MUST NOT drive SERCLK low for its S1 transition until this minimum time after the C1 transition, and it MUST do so within this maximum time after C1.		175	187.5	200
<b>13. Rule 7.6:</b>				
A CLOCK SOURCE + BRIDGE group MUST drive SERCLK low for at least this minimum time, and it MUST NOT drive SERCLK low for more than this maximum time.		25	31.25	45
<b>19. Rule 7.7:</b>				
A CLOCK SOURCE + BRIDGE group MUST NOT drive SERCLK low for its S2 transition until this minimum time after the C2 transition, and it MUST do so within this maximum time after C2.		82	93.75	100
<b>20. Rule 7.8:</b>				
In addition to meeting the above RULES, a CLOCK SOURCE + BRIDGE module MUST drive SERCLK so that the time between successive C1 transitions is between these minimum and maximum values.		340	343.75	347
<b>3. Rule 7.9:</b>				
A BUS ACCESS module MUST not change SERDAT* from the value established in a bit, until SERCLK goes high in its C1 transition at the start of the next bit.		0		
RULE 7.10: IF a BUS ACCESS module is signalled by its Link Layer modules to send a zero-bit followed by a one-bit, THEN it MUST drive SERDAT* low within this maximum time after the C1 transition between these two bits.				25
RULE 7.11: IF a BUS ACCESS module is signalled by its Link Layer modules to send a one-bit or a start bit followed by a zero-bit, THEN it must release SERDAT* within this maximum time after the C1 transition between these two bits.				25
<b>10. Observation 7.1:</b>				
A BUS ACCESS module is guaranteed this minimum time between the C1 and S1 transitions of SERCLK.	Subrack /4 Rate Slower	165 650 10T + 25		
<b>11. Observation 7.2:</b>				
A BUS ACCESS module is guaranteed that SERDAT* is valid for this minimum time before SERCLK goes low.		10		
<b>13. Observation 7.3:</b>				
A BUS ACCESS module is guaranteed this minimum low time on SERCLK		15		
<b>14. Rule 7.12:</b>				
IF a BUS ACCESS module is signalled by its Link Layer modules to send a start-bit, AND it samples SERDAT* high at the S1 transition of SERCLK, THEN it MUST NOT drive SERDAT* low until after the C2 transition of SERCLK, and it MUST do so within this maximum time after C2.		0		25
<b>15. Observation 7.4:</b>				
A BUS ACCESS module is guaranteed that SERDAT* will not change until at least this long after SERCLK goes low.		5		
<b>19. Observation 7.5:</b>				
A BUS ACCESS module is guaranteed these minimum and maximum times between the C2 and S2 transitions of SERCLK.	Subrack /4 Rate Slower	72 275 4T + 25		110 475 8T - 25

# SCB68430

## Direct Memory Access Interface (DMAI)

### Product Specification

#### Microprocessor Products

#### DESCRIPTION

The SCB68430 Direct Memory Access Interface (DMAI) is a single channel interface circuit which is intended to complement the performance and architectural capabilities of the SCN68000 microprocessor. The DMAI functions by transferring a series of operands (data) between memory and a device: operand sizes may be byte, word, or long word. A block is a sequence of operands: the number of operands in the block is determined by a transfer count stored within the DMAI. The SCB68430 can be programmed to utilize single cycle (cycle stealing) or burst data transfers.

The DMAI provides two interfaces. The microprocessor interface is fully compatible with the SCN68000 microprocessor. The device interface includes lines for requesting, acknowledging, controlling, and timing the data transfers. The DMAI is a single-channel subset of the other 68000 family DMA controllers (68440 and 68450). It is software compatible with these devices and provides similar interfacing signals to both the system bus and the device.

The SCB68430 is constructed using Signetics ISL bipolar technology.

#### FEATURES

- Bus compatible with SCN68000 microprocessor
- Software compatible with other 68K family DMA controllers
- Single address transfers
- Cycle steal and burst mode operation
- Bus arbitration daisy chain
- Automatic rerun on bus error
- Supports 32-bit transfers for VME bus
- Supports SCN68000 vectored interrupts
- 24-bit address counter
- 16-bit transfer counter
- Maximum transfer rate of 5 Mbytes per sec
- Signetics ISL bipolar technology

#### PIN CONFIGURATIONS

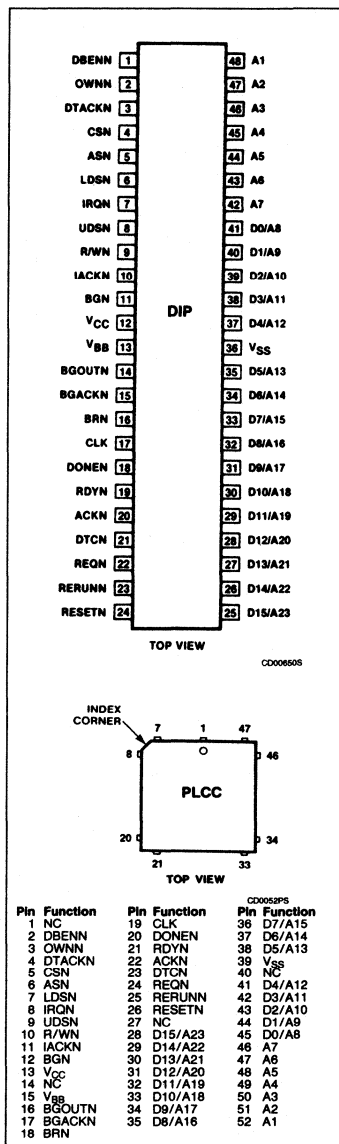

# Direct Memory Access Interface (DMAI)

# SCB68430

**2**

## ORDERING INFORMATION

PACKAGES	$V_{CC} = 5V \pm 5\%$ , $T_A = 0^\circ C$ to $70^\circ C$	
	10MHz	12.5MHz
Ceramic DIP	SCB68430CAI48	SCB68430CCI48
Plastic DIP	SCB68430CAN48	SCB68430CCN48
Plastic LCC	SCB68430CAA52	SCB68430CCA52

## BLOCK DIAGRAM

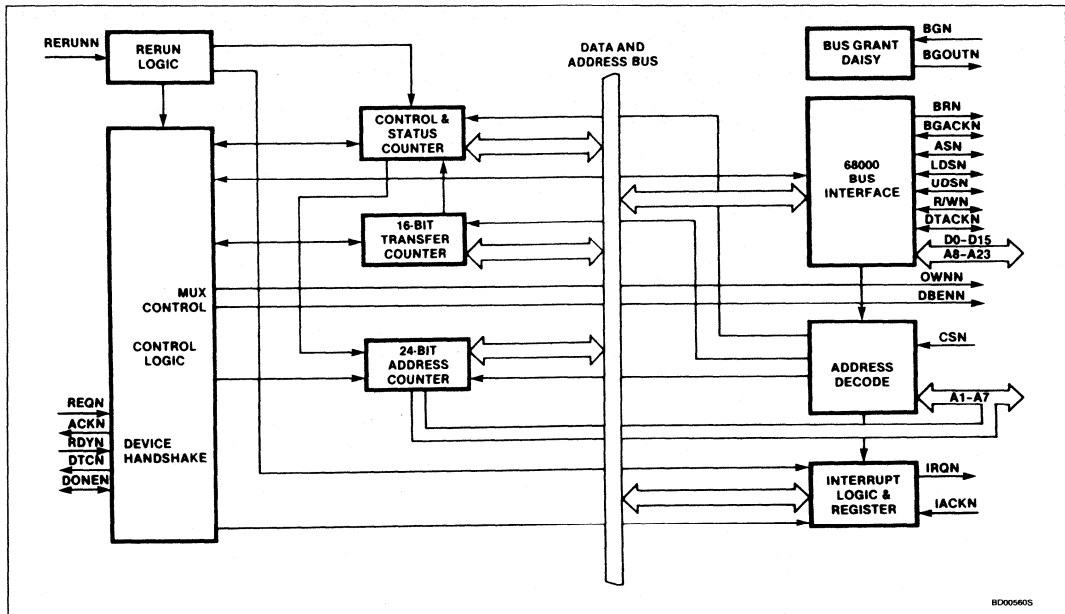

## Direct Memory Access Interface (DMAI)

SCB68430

## PIN DESCRIPTION

MNEMONIC	PIN NO.	TYPE	DESCRIPTION
A1 – A7	48 – 42	I/O	<b>Address Lines:</b> Active high, 3-State. In the MPU mode, these low order address lines specify which internal register of the DMAI is being accessed. In DMA mode, A1 – A7 are outputs which provide the low order address bits of the location being accessed; 3-States in IDLE Mode.
A8 – A23/ D0 – D15	41 – 37 35 – 25	I/O	<b>Address/Data Lines:</b> Active high, 3-State. These lines are time multiplexed for data and address leads. The lines OWNN, RWN, CSN, and DBENN are used to control the demultiplexing of the address and data using external circuitry. In MPU mode, the bidirectional data lines (D0 – D15) are used to transfer data between the MPU and the DMAI. In the DMA mode, A8 – A23 provide the high order address bits of the location being accessed; 3-States in IDLE mode.
ASN	5	I/O	<b>Address Strobe:</b> Active low, 3-State. In MPU and IDLE modes, ASN is an input which indicates that the current bus master has placed a valid address on the bus. It is monitored by the DMAI during bus arbitration to ascertain that the previous bus master has completed the current bus cycle. In DMA mode, it is an output indicating that the DMAI has placed a valid address on the bus.
UDSN	8	I/O	<b>Upper Data Strobe:</b> Active low, 3-State. In MPU and IDLE modes, UDSN is an input which indicates that the upper data byte of the addressed word is being addressed. In DMA mode, it is an output with the same meaning.
LDSN	6	I/O	<b>Lower Data Strobe:</b> Active low, 3-State. In MPU and IDLE modes, LDSN is an input which indicates that the lower data byte of the addressed word is being addressed. In DMA mode, it is an output with the same meaning.
R/WN	9	I/O	<b>Read/Write:</b> Active high for read, low for write, 3-State. In MPU mode, R/WN is an input which controls the direction of data flow through the DMAI's input/output data bus interface and, if required, through an external data bus buffer. R/WN high causes the DMAI to place the data from the addressed register on the data bus, while R/WN low causes the DMAI to accept data from the data bus. In DMA mode, R/WN is an output to memory and I/O controllers indicating the type of bus cycle. It is held 3-States during IDLE mode.
CSN	4	I	<b>Chip Select:</b> Active low. When low, places the DMAI into the MPU mode. This input signal is used to select the DMAI for programmed data transfers. These transfers take place over D0 – D15 as controlled by the R/WN and A1 – A7 inputs. The DMAI is deselected when CSN is high. CSN is ignored during DMA mode.
DTACKN	3	I/O	<b>Data Transfer Acknowledge:</b> Active low, 3-State. In MPU mode, DTACKN is asserted on a write cycle to indicate that the data on the bus has been latched, and on a read cycle or interrupt acknowledge cycle to indicate that valid data is present on the bus. The signal is negated (driven high) when completion of the cycle is indicated by negation of the CSN or IACKN input, and returns to the inactive third state a short time after it is negated. In DMA Mode, DTACKN is an input monitored by the DMAI to determine when the addressed device (memory) has latched the data (write cycle) or put valid data on the bus (read cycle).
RESETN	24	I	<b>Master Reset:</b> Active low. Assertion of this pin clears internal control registers (See Table 1), initializes the interrupt vector register to H'0F', and sets the status register to the default value B'0000 000X', where X is the state of RDYN. All bidirectional I/O lines are 3-States and the DMAI is placed in the IDLE mode.
CLK	17	I	<b>Clock:</b> Active high. Usually the system clock, but may be any clock meeting the electrical specifications. Used by the DMAI to synchronize device functions and external control lines, and may not be gated off at any time.
IRQN	7	O	<b>Interrupt Request:</b> Active low, open collector. This output is asserted, if interrupts are enabled, upon end of transfer, on occurrence of a bus error, and on receipt of an abort from the MPU. The CPU can read the status register to determine the interrupting condition(s), or can respond with an interrupt acknowledge cycle to cause the DMAI to output an interrupt vector on the data bus.
IACKN	10	I	<b>Interrupt Acknowledge:</b> Active low. When asserted, indicates that the current cycle is an interrupt acknowledge cycle. The DMAI normally responds by placing the contents of the interrupt vector register on the data bus and asserting DTACKN. IACKN is not serviced if the DMAI has not generated an interrupt request.
BRN	16	O	<b>Bus Request:</b> Active low, open collector. BRN is asserted by the DMAI to request ownership of the bus after a DMA request is sensed on the REQN input from the I/O device. It is negated when the bus has been granted (BGN low) and BGACKN has been asserted, or, in burst DMA request mode, if the I/O device negates its request at least one clock cycle before BGACKN is asserted.
BGN	11	I	<b>Bus Grant:</b> Active low. BGN indicates to the DMAI that it is to be the next bus master. This signal is originated by the MPU and propagated via a daisy chain or other prioritization mechanism. After BGN is asserted, the DMAI waits until DTACKN, ASN, and BGACKN have become inactive before assuming ownership of the bus by asserting BGACKN.

## Direct Memory Access Interface (DMAI)

SCB68430

## PIN DESCRIPTION (Continued)

MNEMONIC	PIN NO.	TYPE	DESCRIPTION
BGOUTN	14	O	<b>Bus Grant Output:</b> Active low. Daisy chain output which is asserted by the DMAI when BGN is asserted and the DMAI does not have a bus request pending.
BGACKN	15	I/O	<b>Bus Grant Acknowledge:</b> Active low, 3-State. As an input, BGACKN is monitored by the DMAI during the bus arbitration cycle to determine when it can assume ownership of the bus (BGACKN negated). In DMA mode, it is asserted by the DMAI to indicate that it is the bus master. 3-States in MPU and IDLE modes.
RERUNN	23	I	<b>Rerun:</b> Active low. This input is asserted by external error detect logic to indicate a bus error. In DMA mode, the DMAI stops operation and 3-States the data, address, and control lines, except BGACKN. It remains halted until RERUNN becomes inactive, and then re-tries the last bus cycle. If RERUNN is asserted again, the DMAI sets the ERR bit in the status register, stops DMA operation, releases the bus, and interrupts the CPU, if interrupts are enabled, responding with a special interrupt vector when IACKN is asserted. Not monitored in MPU and IDLE modes.
REQN	22	I	<b>DMA Request:</b> Active low. This input from the I/O device requests service from the DMAI and causes the DMAI to request control of the bus. In burst mode, the input is level sensitive, and the DMAI releases the bus after REQN is negated and the current DMA cycle is completed. In cycle steal mode, the REQN input is negative edge triggered. A negative going edge must occur at least one clock cycle before DTCN is asserted to accomplish continuous transfer cycles but not earlier than beginning of master cycle.
ACKN	20	O	<b>DMA Request Acknowledge:</b> Active low. ACKN is asserted by the DMAI to indicate that it has gained the bus and the requested bus cycle is now beginning. It is asserted at the beginning of every bus cycle after ASN has been asserted, and is negated at the end of every bus cycle.
RDYN	19	I	<b>Device Ready:</b> Active low. RDYN is asserted by the requesting device to indicate to the DMAI that valid data has either been stored or put on the bus. If negated, it indicates that the data has not been stored or presented, causing the DMAI to enter wait states. RDYN can be held low continuously if the device is fast enough so that wait states are not required.
DTCN	21	O	<b>Device Transfer Complete:</b> Active low. In DMA mode, DTCN is asserted by the DMAI to indicate to the device that the requested data transfer is complete. On a write to memory operation, it indicates that the data provided by the device has been successfully stored. On a read from memory operation, it indicates to the device that the data from memory is present on the data bus and should be latched.
DONEN	18	I/O	<b>Done:</b> Active low, open collector. As an output, DONEN is asserted by the DMAI concurrent with the ACKN output to indicate to the device that the transfer count is exhausted and that the DMAI's operation is completed as a result of that transfer. As an input, if asserted by the device before the transfer count became zero, it causes the DMAI to abort service and generate an interrupt request, if interrupts are enabled.
OWNN	2	O	<b>Own:</b> Active low, open collector. This output is asserted by DMAI during the DMA mode to indicate bus mastership. It can be used to enable external address/data and control buffers. Inactive in MPU and IDLE modes.
DBENN	1	O	<b>Data Bus Enable:</b> Active low, open collector. Asserted by the DMAI when CSN is asserted or when IACKN is asserted and the DMAI has an interrupt request pending. Can be used to enable bidirectional data buffers for D0–D15. Inactive in IDLE and DMA mode.
V <sub>CC</sub>	12	I	<b>Power Supply:</b> +5V power input.
V <sub>BB</sub>	13	I	<b>Power Supply:</b> +1.5V power input.
V <sub>SS</sub>	36	I	<b>Ground:</b> Signal and power ground input.

## PIN DESCRIPTION

The Pin Description table describes the function of each of the pins of the DMAI. Signal names ending in 'N' are active low. All other signals are active high. In the descriptions, 'MPU mode' refers to the state when the DMAI is chip selected. The term 'DMA mode' refers to the state when the DMAI assumes ownership of the bus. The DMAI is in the 'IDLE mode' at all other times.

In this data sheet signals are discussed using the terms 'active' and 'inactive' or 'asserted' and 'negated' independent of whether the

signal is active in the high (logic one) state or the low (logic zero) state. Refer to the individual pin descriptions for the definition of the active level of each signal.

## REGISTERS AND COUNTERS

## Register Map

The internal accessible register organization of the DMAI is shown in Table 1. The following rules apply to all registers:

1. A read from a reserved location in the map results in a read from the 'null

register'. The null register returns all ones for data and results in a normal bus cycle. A write to one of these locations results in a normal bus cycle but no write occurs.

2. Unused bits of a defined register are read as indicated in the register descriptions.
3. All registers are addressable as 8-bit quantities. To facilitate operation with the 68K MOVEP instruction, addresses are ordered such that certain sets of registers may also be accessed as words or long words.

## Direct Memory Access Interface (DMAI)

SCB68430

The operation of the DMAI is programmed by writing control words into the appropriate registers. Operational feedback is provided via status registers which can be read by the CPU. The contents of certain control and status registers are initialized on RESET.

To provide compatibility with the other 68K family DMA controllers, control and status

bits are mapped in bit positions equivalent to where they are located in the register map of the other devices. Bits which are used in the other devices but not in the DMAI are assigned default values. If upward compatibility to the other controllers is required, the programmer should use these default values when writing the control words to the regis-

ters, although they have no effect in the DMAI. When a register is read, the default value is returned regardless of the value used when the register is programmed. The default value is indicated by '(x)' in unused bit positions in the register formats, which are illustrated in Table 2.

Table 1. DMAI Address Map

ADDRESS BITS <sup>1, 2</sup> 7 6 5 4 3 2 1 0	ACRONYM	REGISTER NAME	MODE	AFFECTED BY RESET
d d 0 0 0 0 0 0	CSR	Channel Status Register	R/W <sup>3</sup>	Yes
d d 0 0 0 0 0 1	CER	Channel Error Register	R	Yes
d d 0 0 0 0 1 0		Reserved		
d d 0 0 0 0 1 1		Reserved		
d d 0 0 0 1 0 0	DCR	Device Control Register	R/W	Yes
d d 0 0 0 1 0 1	OCR	Operation Control Register	R/W	Yes
d d 0 0 0 1 1 0	SCR	Sequence Control Register	R/W <sup>4</sup>	No
d d 0 0 0 1 1 1	CCR	Channel Control Register	R/W	Yes
d d 0 0 1 0 0 0		Reserved		
d d 0 0 1 0 0 1		Reserved		
d d 0 0 1 0 1 0	MTCH	Memory Transfer Counter High	R/W	No
d d 0 0 1 0 1 1	MTCL	Memory Transfer Counter Low	R/W	No
d d 0 0 1 1 0 0	MACH	Memory Address Counter High	R/W <sup>4</sup>	No
d d 0 0 1 1 0 1	MACMH	Memory Address Counter Middle High	R/W	No
d d 0 0 1 1 1 0	MACML	Memory Address Counter Middle Low	R/W	No
d d 0 0 1 1 1 1	MACL	Memory Address Counter Low	R/W	No
d d 0 1 d d d d		Reserved		
d d 1 0 0 0 d d		Reserved		
d d 1 0 0 1 0 0		Reserved		
d d 1 0 0 1 0 1	IVR	Interrupt Vector Register - Normal	R/W	Yes
d d 1 0 0 1 1 0		Reserved		
d d 1 0 0 1 1 1	IVR	Interrupt Vector Register - Error	R/W	Yes
d d 1 0 1 0 d d		Reserved		
d d 1 0 1 1 0 0		Reserved		
d d 1 0 1 1 0 1	CPR	Channel Priority Register	R/W <sup>4</sup>	No
d d 1 0 1 1 1 0		Reserved		
d d 1 0 1 1 1 1		Reserved		
d d 1 1 d d d d		Reserved		

## NOTES:

- A0 = 0 for UDSN asserted, A0 = 1 for LDSN asserted.
- 'd' designates don't care.
- A write to this register may perform a status resetting operation.
- This register is a dummy register present only to provide compatibility with other 68K family DMA controllers. A write to this register has no effect on the DMAI.

Table 2. Register Bit Formats

## DEVICE CONTROL REGISTER

	BIT15	BIT14	BIT13	BIT12	BIT11	BIT10	BIT09	BIT08
EXTERNAL REQUEST MODE								
DCR	NOT USED (0)	NOT USED (1)	NOT USED (1)	NOT USED (*)	NOT USED (0)	NOT USED (0)	NOT USED (0)	NOT USED (0)
	0 = BURST 1 = CYCLE STEAL							

## NOTE:

\*Should be programmed as '0' for SIZE (OCR[5:4]) = 00 and as '1' otherwise. When read, the value of this bit is OCR[5]. OR.OCR[4].



## Direct Memory Access Interface (DMAI)

SCB68430

Table 2. Register Bit Formats (Continued)

OPERATION CONTROL REGISTER (OCR)								
	BIT07	BIT06	BIT05	BIT04	BIT03	BIT02	BIT01	BIT00
OCR	DIRECTION	NOT USED (0)	OPERAND SIZE		NOT USED (0)	NOT USED (0)	NOT USED (1)	NOT USED (0)
	0 = MEM TO DEV 1 = DEV TO MEM		00 = BYTE 01 = WORD (16 BIT) 10 = LONG WORD* 11 = WORD (32-BIT)*					

## NOTE:

\*Long word and 32-bit word modes are not supported by 68440. 32-bit word mode is not supported by 68450.

SEQUENCE CONTROL REGISTER (SCR)								
	BIT15	BIT14	BIT13	BIT12	BIT11	BIT10	BIT09	BIT08
SCR	NOT USED (0)	NOT USED (0)	NOT USED (0)	NOT USED (0)	NOT USED (0)	NOT USED (1)	NOT USED (0)	NOT USED (0)

CHANNEL CONTROL REGISTER (CCR)								
	BIT07	BIT06	BIT05	BIT04	BIT03	BIT02	BIT01	BIT00
CCR	START	NOT USED (0)	NOT USED (0)	SOFTWARE ABORT	INTERRUPT ENABLE	NOT USED (0)	NOT USED (0)	NOT USED (0)
	0 = NO 1 = YES			0 = NO 1 = YES	0 = NO 1 = YES			

CHANNEL STATUS REGISTER (CSR)								
	BIT15	BIT14	BIT13	BIT12	BIT11	BIT10	BIT09	BIT08
CSR	CHANNEL OPERATION COMPLETE	NOT USED (0)	NORMAL DEVICE TERMINATE	ERROR	CHANNEL ACTIVE	NOT USED (0)	NOT USED (0)	READY INPUT STATE
	0 = NO 1 = YES		0 = NO 1 = YES	0 = NO 1 = YES	0 = NO 1 = YES			0 = LOW 1 = HIGH

CHANNEL ERROR REGISTER (CER)								
	BIT07	BIT06	BIT05	BIT04	BIT03	BIT02	BIT01	BIT00
CER	NOT USED (0)	NOT USED (0)	NOT USED (0)	ERROR CODE				
				00000 = NO ERROR 01001 = BUS ERROR 10001 = SOFTWARE ABORT				

CHANNEL PRIORITY REGISTER (CPR)								
	BIT07	BIT06	BIT05	BIT04	BIT03	BIT02	BIT01	BIT00
CPR	NOT USED (0)	NOT USED (0)	NOT USED (0)	NOT USED (0)	NOT USED (0)	NOT USED (0)	NOT USED (0)	NOT USED (0)

**Device Control Register (DCR)****[15] External Request Mode**

This bit selects whether the DMAI operates in burst or cycle steal mode.

- 0 Burst mode. This mode allows a device to request the transfer of multiple operands using consecutive bus cycles. In

this mode the request (REQN) line is an active low input which is asserted by the device to request an operand transfer. The DMAI services the request by arbitrating for the bus, obtaining the bus, and notifying the peripheral by asserting the acknowledge (ACKN) output. If the request line is active when the DMAI as-

serts ACKN, and remains active at least until the DMAI asserts device transfer complete (DTCN), the DMAI recognizes a valid request for another operand, which will be transferred during the next bus cycle. If the request line is negated before the DMAI asserts DTCN, the DMAI relinquishes the bus and waits for the

## Direct Memory Access Interface (DMAI)

SCB68430

next request, but the current transfer will be completed.

- 1 Cycle steal mode. In this mode, the device requests an operand transfer by generating a falling edge on the request (REQN) line. The DMAI services the request by arbitrating for the bus, obtaining the bus, and notifying the peripheral by asserting the acknowledge (ACKN) output. The request line must be in the inactive state for at least one clock cycle before a request is made. After a request has been asserted, it must remain at the assertion level for at least one clock cycle. If another request is received before the first operand part of a former request is acknowledged, the second request is not recognized. Normally, the DMAI will relinquish the bus after servicing a valid request. However, if the device generates a new request before the DMAI asserts DTCN for the last operand part, the DMAI will retain ownership of the bus and that request will be serviced before the bus is relinquished.

### Operation Control Register (OCR)

#### [7] Direction

- 0 Transfer is from memory to device.  
1 Transfer is from device to memory.

#### [5:4] Operand Size

The programming of these bits determine whether UDSN, LDSN, or both are generated during the transfer cycle and the increment by which the memory address counter (MAC) is changed in each transfer cycle.

- 00 Byte. The operand size is 8 bits. The MAC is incremented by one after each operand transfer. If the LSB of the MAC is a '0', UDSN is asserted during the transfer. If the LSB of a MAC is a '1', LDSN is asserted during the transfer. The transfer counter decrements by one before each byte is transferred.
- 01 Word. The operand size is 16 bits. The MAC is incremented by two after each operand transfer. The value of the LSB of the MAC is ignored and both UDSN and LDSN are asserted during the transfer. The transfer counter decrements by one before each word is transferred.
- 10 Long word. The operand size is 32 bits. The operand is transferred as two 16-bit words. The MAC is incremented by two after each 16-bit word is transferred. The value of the LSB of the MAC is ignored and both UDSN and LDSN are asserted during the transfer. The transfer counter decrements by one before the entire long word is transferred. Note that this mode is not implemented in the 68440.

- 11 Double word. The operand size is 32 bits. The operand is transferred as a single 32-bit word. The MAC is incremented by four after each operand transfer. The value of the two LSBs of the MAC is ignored (the A1 output will always be a zero in this mode) and both UDSN and LDSN are asserted during the transfer. The transfer counter decrements by one before the double word is transferred. Note that this mode is not implemented in the 68440 or 68450; it is included in the DMAI to support VME bus operations.

### Sequence Control Register (SCR)

This register serves no function in the DMAI. It is included only to provide compatibility with the programming for the 68440 and 68450 DMA controllers.

### Channel Control Register (CCR)

#### [7] Start Operation

- 0 No start pending.
- 1 Start operation. The start bit is set to initiate operation of the DMAI. The memory address counter and the memory transfer counter should have been previously initialized, and all bits of the channel status register (CSR) should have previously been reset. The DMAI initiates operation by clearing any pending requests, clearing the start bit, and setting the channel active bit in the CSR. The DMAI is then ready to receive requests for an operation. The channel cannot be started if any of the internal status bits in the CSR (CSR[15:11]) have not been cleared. A pending start cannot be reset by a write to the register. START can be cleared only by the DMAI when it starts operation or by setting the software abort bit (CCR[4]).

#### [4] Software Abort

- 0 Do not abort.
- 1 Abort operation. Setting this bit terminates the current operation of the DMAI and places it in the IDLE state. The channel operation complete and error bits in the CSR are set, the channel active bit in the CSR is reset, and an ABORT ERROR condition is signaled in the CER. Setting this bit causes a pending start to be reset.

#### [3] Interrupt Enable

- 0 Interrupts not enabled.
- 1 Enable interrupts. An interrupt request is generated if the channel operation complete bit in the CSR is set. When the IACKN input is asserted, the DMAI returns the normal interrupt vector if the

error bit in the CSR is not set, or the error interrupt vector if error is set.

### Channel Status Register (CSR)

A read of this register provides the status of the DMAI. The COC, NDT, and ERR bits can be cleared by writing a '1' to the bit positions of the register which are to be cleared. Those bit positions which are written with a '0' remain unaffected.

#### [15] Channel Operation Complete

This bit is set following the termination, whether successful or not, of any DMAI operation and indicates that the DMA transfer has completed. This bit must be cleared to start another channel operation.

#### [13] Normal Device Termination

This bit is set when the device terminates the DMAI operation by asserting the DONEN line while the device was being acknowledged. This bit must be cleared to start another channel operation.

#### [12] Error

This bit is used to report that the DMAI's operation was terminated due to the occurrence of an error. The condition which caused the error can be determined by reading the channel error register (CER). This bit must be cleared to start another channel operation. When this bit is cleared, the CER is also cleared.

#### [11] Channel Active

This bit is set after the channel has been started and remains set until the channel operation terminates. It is then automatically cleared by the DMAI. The bit is unaffected by the write operations.

#### [8] Ready Input State

This bit reflects the state of the RDYN input at the time the CSR is read. The bit is a '0' if RDYN is low and a '1' if RDYN is high. This bit is unaffected by write or reset operations.

### Channel Error Register (CER)

#### [4:0] Error Code

This field indicates the source of error when an error is indicated in CER[12]. The contents of this register are cleared when CER[12] is cleared.

00000 No error.

01001 Bus error. A bus error occurred during the last bus cycle generated by the DMAI. See rerun description in OPERATION section.

10001 Software abort. The channel operation was terminated by a software abort command. See CCR[4].

### Channel Priority Register (CPR)

This register serves no function in the DMAI. It is included only to provide compatibility with

## Direct Memory Access Interface (DMAI)

SCB68430

the programming for the other 68K family DMA controllers.

### Memory Address Counter (MACH, MACMH, MACML, MACL)

The 32-bit memory address counter is used to program the memory location where the first operand to be transferred is located or is to be transferred to, depending on the direction of transfer. The counter must be initialized prior to beginning the transfer of a block of data and then increments automatically depending on the operand length, as described in the Operation Control Register description.

Only the least significant 24 bits of the counter (MACMH, MACML, and MACL) are implemented in the DMAI. The most significant byte of the counter, MACH, is provided only to allow compatibility with programming of the 68440 and 68450. Writing to MACH has no effect on the DMAI operation. Reading MACH always returns H'00'.

### Memory Transfer Counter (MTCH, MTCL)

The 16-bit memory transfer counter programs the number of operands to be transferred by the DMAI. The counter must be initialized prior to beginning the transfer of a block of data and then decrements once per operand transfer (regardless of operand size) until it reaches the terminal value of zero. Channel operation then terminates and the COC bit in the CSR will be asserted.

### Interrupt Vector Register (IVR)

The IVR contains the value to be placed on the data bus upon receipt of an interrupt acknowledge from the MPU. Only the seven most significant bits of the programmed value are used by the DMAI. The output vector from the DMAI contains a zero in the least significant bit position if a normal termination occurred (error bit not set) and contains a one in the least significant bit position if termination was due to an error (error bit set).

The contents of this register are initialized to H'0F' by a reset. The value returned will be H'0F', regardless of the error state, until the register is programmed by the MPU.

To provide compatibility with the other 68K family DMA controllers, the IVR has two addresses (see Table 1). If program compatibility is required, the value written at the normal IVR address should have a zero as its LSB, and the value written at the error IVR address should be the same but with the LSB equal to one.

### OPERATION

A DMAI operation proceeds in three principal phases. During the initialization phase, the MPU configures the channel control registers, loads the initial memory address and transfer count, and starts the channel. During the transfer phase, the DMAI accepts requests for transfers from the device, arbitrates for and acquires ownership of the bus, and provides for addressing and bus controls for the transfers. The termination phase occurs after the operation is complete, when the DMAI reports the status of the operation.

#### Operation Initiation

After having programmed the control registers, the memory address counter, and the memory transfer counter, the MPU sets the start bit (CCR[7]). The DMAI initiates the operation by clearing any pending requests, clearing the start bit, and setting the channel active bit in the CSR. The DMAI is then ready to receive valid requests for an operation.

The channel cannot be started if any of the internal status bits in the CSR (CSR[15:11]) have not been cleared. An error is not signaled if this condition occurs. The only indication of this state is that the start bit remains set in the CCR. A pending start cannot be reset by a write to the register. START can be cleared only by the DMAI when it starts operation or by setting the software abort bit (CCR[4]).

#### Device/DMAI Communication

Communication between the peripheral device and the DMAI is accommodated by five signal lines:

##### Request (REQN)

The device makes a request for service by asserting the request line. The DMAI can operate in either the burst request mode or the cycle stealing request mode, as programmed by the external request mode bit (DCR[15]).

The burst mode allows a device to request the transfer of multiple operands using consecutive bus cycles. In this mode the request line is an active low input. The DMAI services the request by arbitrating for the bus, obtaining the bus, and notifying the peripheral by asserting the acknowledge (ACKN) output. If the request line is active when the DMAI asserts ACKN, and remains active at least until the DMAI asserts device transfer complete (DTCN), the DMAI recognizes a valid request for another operand, which will be transferred during the next bus cycle. If the request line is negated before the DMAI asserts DTCN, the DMAI relinquishes the bus and waits for the next request. For long word transfers ( $2 \times 16$ ), the request must be asserted at least until the acknowledge for the

second part of the operand has been asserted.

In the cycle steal mode, the device requests an operand transfer by generating a falling edge on the request line. The DMAI services the request by arbitrating for the bus, obtaining the bus, and notifying the peripheral by asserting the acknowledge (ACKN) output. The request line must be in the inactive state for at least one clock cycle before a request is made. After a request has been asserted, it must remain at the assertion level for at least one clock cycle. If another request is received before the first operand part of a former request is acknowledged, the second request is not recognized. Normally, the DMAI will relinquish the bus after servicing a valid request. However, if the device generates a new request before the DMAI asserts DTCN for the last operand part, the DMAI will retain ownership of the bus and that request will be serviced before the bus is relinquished. During burst mode, REQN must not be disasserted for less than one CLK period plus four RC time constants, where R is the value of the resistor used for the pullup on BRN and C has a typical value of 20pF.

##### Acknowledge (ACKN)

The DMAI asserts the acknowledge line, which implicitly addresses the device making the request, during transfers to and from the device. The line may be used to control buffering circuits between the data bus and the MPU bus.

##### Ready (RDYN)

Ready is an active low input which is asserted by the requesting device to indicate to the DMAI that valid data has either been stored or put on the bus. If negated, it indicates that the data has not been stored or presented, causing the DMAI to enter wait states until RDYN is asserted. RDYN can be held low continuously if the device is fast enough so that wait states are not required. The current state of the ready input is reflected in CSR[8].

##### Done (DONEN)

Done is a bidirectional active low signal. As an output, it is asserted and negated by the DMAI concurrent with the ACKN output of the last operand part to indicate to the device that the memory transfer count is exhausted and that the DMAI's operation is completed as a result of that transfer.

The DMAI also monitors the state of the line while acknowledging a device. If the device asserts DONEN, the DMAI will terminate operation after the transfer of the current operand. In this case the DMAI clears the channel active bit and sets the channel operation complete and normal device termination bits in the CSR. If both the DMAI and the device assert DONEN, the device termination

2

# Direct Memory Access Interface (DMAI)

SCB68430

is not recognized, but the operation does terminate.

### Device Transfer Complete (DTCN)

DTCN is an active low output which is asserted by the DMAI to indicate to the device that the requested data transfer is complete. On a write to memory operation, it indicates that the data provided by the device has been successfully stored. On a read from memory operation, it indicates to the device that the data from memory is present on the data bus and should be latched. DTCN is not asserted if assertion of the RERUNN input terminates the bus cycle.

### Bus Arbitration

Upon receiving a valid request for a transfer from the device, the DMAI will arbitrate for and obtain ownership of the system bus.

The DMAI indicates that it wishes to become the bus master by asserting its bus request (BRN) output. This is a wire-ORed signal that indicates to the MPU that some external device requires control of the bus. The processor is effectively at a lower priority level than external devices and will relinquish the bus after it has completed the last bus cycle it has started. The processor puts the bus up for external arbitration by asserting its bus grant (BGN) output. This signal may be routed through a daisy chain (such as provided by the DMAI) or through some other priority-encoded network. When the DMAI making the bus request receives the bus grant (indicated by its BGN input being asserted), it is to be the next bus master. It waits until address strobe (ASN), data transfer acknowledge (DTACKN) and bus grant acknowledge (BGACKN) become inactive and then assumes ownership of the bus by asserting its own BGACKN output. The DMAI then negates the BRN output and proceeds with the data transfer phase. After this phase is completed, the DMAI relinquishes bus ownership by negating the BGACKN output.

In burst DMA mode, detection of an active low request input after the DMAI operation has been started will begin the bus arbitration cycle. However, if the device negates its request at least one clock cycle before the DMAI asserts BGACKN, the DMAI will negate its bus request and will not assume ownership of the bus.

### Data Transfers

The actual transfer of data between the memory and the device occurs during the data transfer phase. All transfers occur during a single cycle except in the case of long word operands, in which case two cycles are used to transfer the operand as two 16-bit words. The transfers take place using a 'single address' protocol; the DMAI addresses the memory via the bus address lines, while the

device is implicitly addressed via the acknowledge output.

When a request is generated using the request method programmed in the control register, the DMAI obtains the bus and asserts acknowledge to notify the device that a transfer is to take place. The DMAI asserts all S68000 bus control signals needed for the transfer and holds them until the device responds with ready. The bus cycle then terminates normally. Ready may be tied low (asserted) if the device is fast enough.

When the transfer is from memory to the device, data is valid when DTACKN is asserted by the memory and remains valid until the data strobe(s) are negated. The assertion of DTCN from the DMAI can be used to latch the data, as the data strobes are not removed until one-half clock after the assertion of DTCN.

When the transfer is from device to memory, the data must be valid on the bus before the DMAI asserts the data strobe(s). The device indicates valid data by asserting ready. The DMAI then asserts the strobes and holds them asserted until the memory accepts the data, indicated by the assertion of DTACKN. The DMAI then asserts DTCN and negates the data strobes.

Flowcharts for these operations are shown in Figures 1 and 2. Refer to the timing section for the equivalent timing diagrams.

### Operation Termination

Termination of the block transfer occurs under the conditions detailed below.

#### Terminal Count

As part of each transfer of an operand, the DMAI decrements the memory transfer counter. If this counter is decremented to zero, the operand is the last operand of the block. The DMAI operation is complete and it notifies the device of completion by asserting the DONEN output during the last operand transfer cycle. When the transfer has been completed, the channel active bit in the CSR is cleared and the COC bit is set, unless an error occurs.

#### Device Termination

The DMAI monitors the state of the DONEN line while acknowledging a device transfer request. If the device asserts DONEN, the DMAI will terminate operation after the transfer of the current operand. When the transfer has been completed, the DMAI clears the channel active bit and sets the COC and normal device termination bits in the CSR. If both the DMAI and the device assert DONEN, the device termination is not recognized, but the operation does terminate.

### Software Abort

The software abort bit (CCR[4]) allows the MPU to abort the current operation of the DMAI. The COC and error bits in the CSR are set, the channel active bit in the CSR is cleared, and an abort error condition is signaled in the CER.

### Rerun Error

The DMAI provides a rerun input (RERUNN) to indicate a bus exception condition. RERUNN must arrive prior to or in coincidence with DTACKN in order to be recognized, and the DMAI verifies that the line has been stable for two clock cycles before acting on it. The occurrence of a rerun during a DMAI bus cycle forces it to terminate the bus cycle in an orderly manner.

When the assertion of rerun is verified, the DMAI stops operation and 3-States the data, address, and control lines, except BGACKN, so that it retains ownership of the bus. It remains halted until rerun becomes inactive, and then re-tries the last bus cycle. If rerun is asserted again, the DMAI stops DMA operation, releases the bus, sets the error and COC bits in the CSR, clears the active bit in the CSR, and sets the error code in the CER to indicate a bus error.

While stopped due to assertion of rerun, the DMAI does not generate any bus cycles and will not honor any requests until it is removed. However, the DMAI still recognizes requests.

### Error Recovery Procedure

If an error occurs during a DMA transfer such that the DMAI stops the DMA operation, information is available to the operating system for an error recovery routine.

The information available to the operating system consists of the memory address counter, the memory transfer counter, and the control, status, and error registers. The DMAI decrements the memory transfer counter before attempting a DMA operation, so the register will contain the count minus one of the attempted transfer. The memory address counter will contain the address at which the DMA operation was attempted.

### Reset

The reset input (RESETN) provides a means of resetting and initializing the DMAI from an external source. If the DMAI is a bus master when reset is received, the DMAI relinquishes the bus. Reset clears the control and error registers, sets all bits of the status register except CSR[8] to zero, and initializes the interrupt vector register to H'0F'.

### Interrupts

The interrupt enable bit (CCR[3]) determines whether the DMAI generates interrupt requests. When the bit is set, an interrupt request is generated if the channel operation complete bit in the CSR is set. When the

Direct Memory Access Interface (DMAI)

SCB68430

2

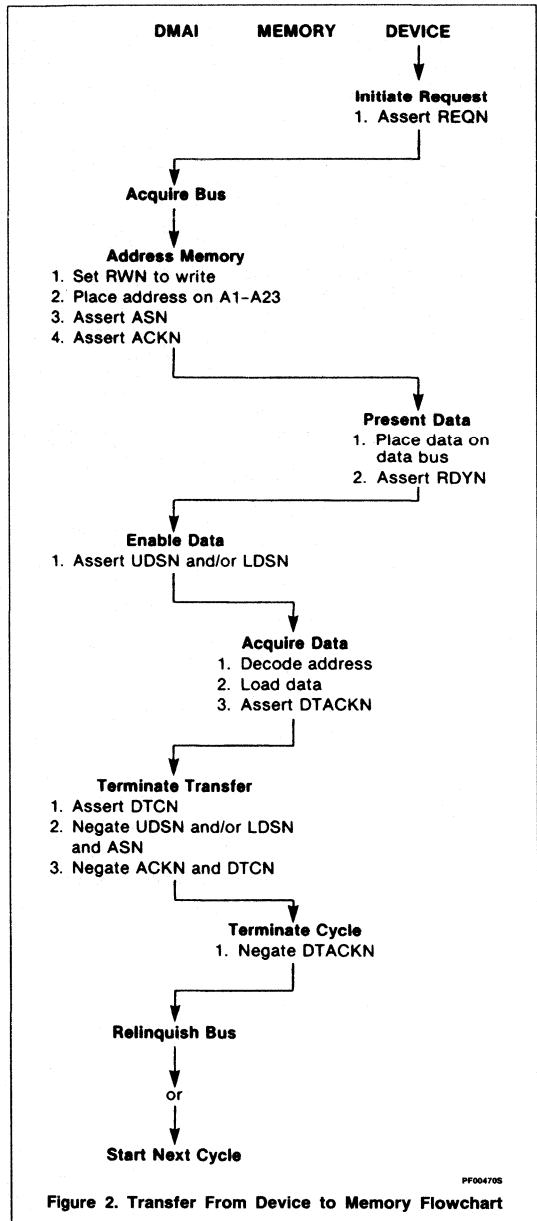
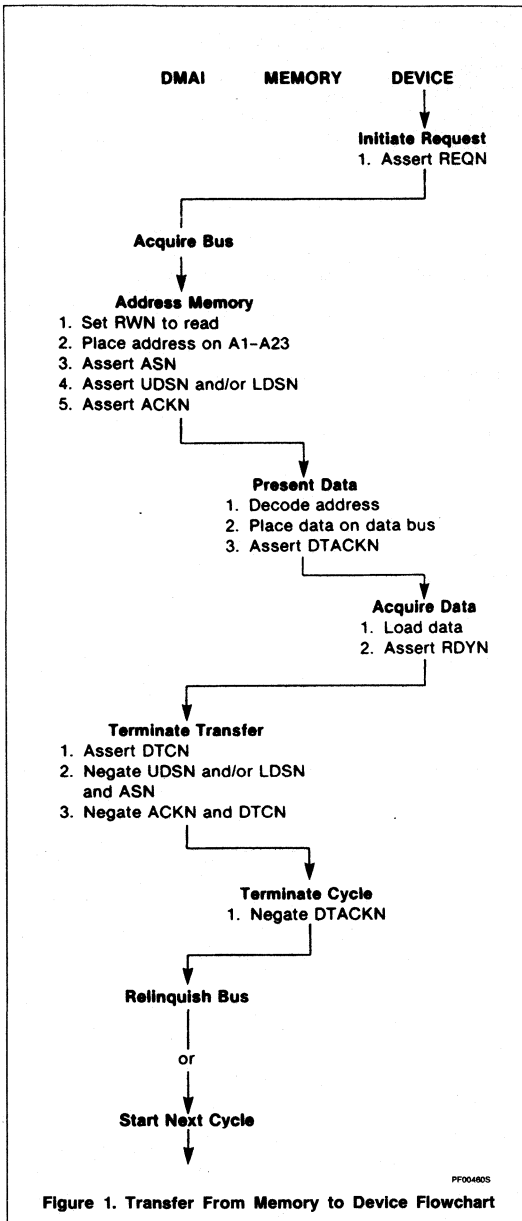

# Direct Memory Access Interface (DMAI)

# SCB68430

IACKN input is asserted, and the DMAI has an interrupt request pending, the DMAI returns an interrupt vector on the data bus.

The interrupt vector issued is the contents of the IVR. Only the seven most significant bits of the programmed value are used by the DMAI. The vector from the DMAI contains a zero in the LSB position if a normal termination occurred (error bit not set) and contains a one in the LSB position if termination was due to an error (error bit set).

The contents of this register are initialized to H'0F' by a reset. The value returned will be H'0F', regardless of the error state, until the register is programmed by the MPU.

To provide compatibility with the other 68K family DMA controllers, the IVR has two addresses (see Table 1). If program compatibility is required, the value written at the normal IVR address should have a zero as its LSB, and the value written at the error IVR address should be the same but with the LSB equal to one.

### APPLICATIONS

Figure 3 illustrates a typical interconnection of the DMAI in a 68000 based system.

### DESIGN NOTE

When clearing the error bit in CSR (bit 12) after a DMAI abort due to a double RERUNN,

ACKN and DTCN will both go low concurrent with CSN and DTACKN for one CLK cycle.

To prevent the possibility that the device may misinterpret these signals, it is suggested that these signals be ANDed with CSN (see figure below).

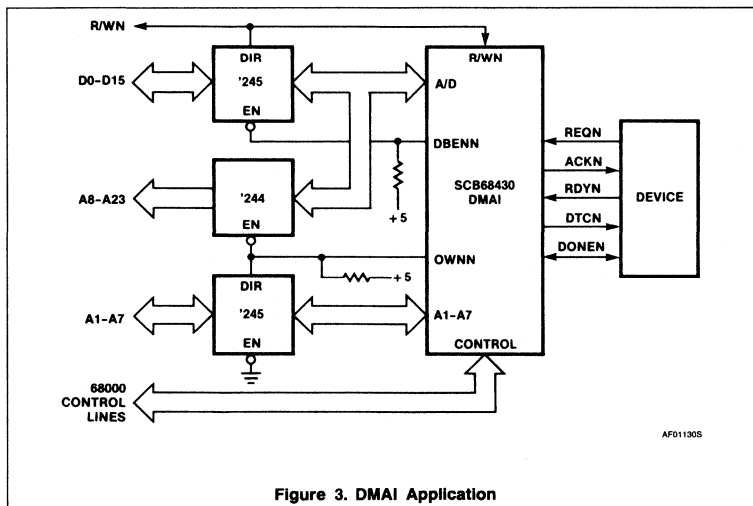
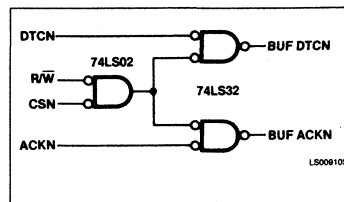

Figure 3. DMAI Application

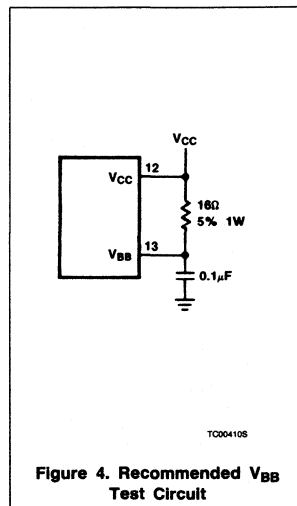

Figure 4. Recommended V<sub>BB</sub> Test Circuit

## Direct Memory Access Interface (DMAI)

SCB68430

ABSOLUTE MAXIMUM RATINGS<sup>1</sup>

SYMBOL	PARAMETER	RATING	UNIT
V <sub>CC</sub> , V <sub>BB</sub>	Supply voltages	-0.5 to +7.0	V
V <sub>IN</sub>	Input voltage range	-0.5 to +5.5	V
T <sub>A</sub>	Operating temperature range <sup>2</sup>	0 to +70	°C
T <sub>STG</sub>	Storage temperature range	-65 to +150	°C

DC ELECTRICAL CHARACTERISTICS V<sub>CC</sub> = 5V ± 5%, V<sub>BB</sub> = Figure 4, T<sub>A</sub> = 0°C to +70°C<sup>3, 4, 7</sup>

SYMBOL	PARAMETER	TEST CONDITIONS	LIMITS		UNIT
			Min	Max	
V <sub>IL</sub> V <sub>IH</sub>	Input low voltage Input high voltage		2	0.8	V V
V <sub>OL</sub> V <sub>OH</sub>	Output low voltage Output high voltage, all outputs except open collector outputs <sup>5</sup>	I <sub>OUT</sub> = 5.3mA I <sub>OUT</sub> = -400μA	2.5	0.5	V V
I <sub>IL</sub> I <sub>IH</sub> I <sub>OC</sub> I <sub>SC</sub>	Input low current Input high current Open collector off state current <sup>5</sup> Output short circuit current <sup>6</sup>	V <sub>IN</sub> = 0.4V V <sub>IN</sub> = 2.7V V <sub>OUT</sub> = 2.4V V <sub>CC</sub> = Max	-40	-400 20 20 -100	μA μA μA mA
I <sub>CC</sub> I <sub>BB</sub>	V <sub>CC</sub> supply current V <sub>BB</sub> supply current	V <sub>CC</sub> = Max		130 275	mA mA

## NOTES:

- Stresses above those listed under Absolute Maximum Ratings may cause permanent damage to the device. This is stress rating only and functional operation of the device at these or at any other conditions other than those indicated in the Electrical Characteristics section of this data sheet is not implied.
- For operating at elevated temperatures, the device must be derated based on +150°C maximum junction temperature.
- Parameters are valid over specified temperature range.
- All voltage measurements are referenced to ground (V<sub>SS</sub>). For testing, all signals swing between 0.4V and 2.4V with a transition time of 20ns maximum. All time measurements are referenced at input voltages of 0.8V and 2V as appropriate.
- IRQN, BRN, DONEN, and OWNN are open collector outputs.
- No more than one output should be connected to ground at one time.
- Capacitive test load is 100pF for all pins except DTCN which has a 35pF capacitive test load.

AC ELECTRICAL CHARACTERISTICS V<sub>CC</sub> = 5V ± 5%, V<sub>BB</sub> = Figure 4, T<sub>A</sub> = 0°C to +70°C<sup>3, 4, 7</sup>

NO.	FIGURE	CHARACTERISTICS	TENTATIVE LIMITS				UNIT
			10MHz		12.5MHz		
			Min	Max	Min	Max	
1	5	A1 - A7, ASN, RWN, setup to UDSN, LDSN low	0		0		ns
2	5	D0 - D15 3-State to invalid data from ASN, CSN, and UDSN or LDSN low	10		10		ns
3	5	DTACKN 3-State to high from ASN, CSN, and UDSN or LDSN low	10		10		ns
4	5	CSN low after UDSN or LDSN low		25		25	ns
5	5, 6	DBENN low after ASN and CSN low		60		60	ns
6	5	D0 - D15 valid data from ASN, CSN, and UDSN or LDSN low		100		100	ns
7	5	DTACKN low after D0 - D15 valid data	-15	30	-15	30	ns
8	5	A1 - A7, ASN, RWN or CSN hold after UDSN and LDSN high	0		0		ns
9	5, 6	DBENN high from either ASN or CSN high		45		45	ns
10	5	D0 - D15 to 3-State from UDSN and LDSN high		80		80	ns
11	5	D0 - D15 to invalid data from UDSN and LDSN high	10		10		ns
12	5, 6	DTACKN high from UDSN and LDSN high		55		55	ns
13	5, 6	DTACK 3-State from either CSN or ASN high		85		85	ns
14	6	A1 - A7, ASN, RWN setup to UDSN, LDSN low	50		50		ns
15	6	CSN setup before UDSN or LDSN low	20		20		ns
16	6	DTACKN 3-State to high after CSN and ASN low	10		10		ns
17	6	D0 - D15 valid after UDSN or LDSN low		0		0	ns
18	6	DTACKN low from UDSN or LDSN low		100		100	ns
19	6	UDSN and LDSN low time	115		100		ns
20	6	A1 - A7 hold after UDSN and LDSN high	0		0		ns
21	6	ASN, RWN and CSN hold after UDSN and LDSN high	0		0		ns

## Direct Memory Access Interface (DMAI)

SCB68430

## AC ELECTRICAL CHARACTERISTICS (Continued)

NO.	FIGURE	CHARACTERISTICS	TENTATIVE LIMITS				UNIT
			10MHz		12.5MHz		
			Min	Max	Min	Max	
22	6	D0 - D15 hold after UDSN and LDSN high	0		0		ns
23	7	DBENN low from last low of ASN, IACKN, LDSN		65		65	ns
24	7	D0 - D7 valid after last low of ASN, IACKN, LDSN		105		105	ns
25	7	DTACKN 3-State to high after last low of ASN, IACKN, LDSN		100		100	ns
26	7	DTACKN low after last low of ASN, IACKN, LDSN		110		110	ns
27	7	DBENN high after first high of ASN, IACKN, LDSN		55		55	ns
28	7	D0 - D7 hold after first high of ASN, IACKN, LDSN		60		60	ns
29	7	D0 - D7 3-State after first high of ASN, IACKN, LDSN		80		80	ns
30	7	DTACKN high after first high of ASN, IACKN, LDSN		60		60	ns
31	7	DTACKN 3-State after first high of ASN, IACKN, LDSN		95		95	ns
32	8	BRN high from CLK high		65		65	ns
33	8, 11, 12	BGACKN low from CLK low		75		75	ns
34	8, 11, 12	OWNN low from CLK high		75		75	ns
35	8	BGACKN high from CLK low		75		75	ns
36	8, 11, 12	OWNN high from CLK high (load dependent)		50		50	ns
37	10	REQN setup before CLK low	30		30		ns
38	10	REQN hold after CLK high	20		20		ns
39	10	BRN low from CLK high		80		80	ns
41	11, 12	ASN, UDSN, LDSN, RWN 3-State to high from CLK low		75		75	ns
43	11, 12	A1 - A23 to valid ASN	0		0		ns
44	11, 12	ASN low from CLK high		65		65	ns
45	11, 12	LDSN, UDSN low from CLK high		90		90	ns
46	11, 12	ACKN low from CLK high		65		65	ns
47	11, 12	DTACKN setup to CLK high	30		30		ns
48	11, 12	RDYN setup to CLK low	30		30		ns
49	11, 12	DTCN low from CLK high		70		70	ns
50	11, 12	ASN high from CLK high		75		75	ns
51	11, 12	LDSN, UDSN, high from CLK high		90		90	ns
52	11, 12	DTACKN, RDYN hold after CLK high	0		0		ns
-	11, 12	ASN, LDSN, UDSN, high from DTCN low	-20		-20		ns
53	11, 12	ACKN high from CLK high		50		50	ns
54	11, 12	DTCN high from CLK high		50		50	ns
55	11, 12	Address valid after CLK low	10		10		ns
-	11, 12	Address valid after ASN high	0		10		ns
56	11, 12	DONEN (output) low from CLK low		120		120	ns
57	11, 12	DONEN (output) high from CLK high		50		50	ns
58	11, 12	DONEN (input) setup low before CLK low	30		30		ns
59	11, 12	DONEN (input) hold low after CLK high	0		0		ns
60	11, 12	BGACKN, ASN, UDSN, LDSN, RWN to 3-State from CLK low		75		75	ns
62	11, 12	A1 - A23 valid to 3-State from CLK high		100		100	ns
63	12	R/WN low from CLK high		65		65	ns
64	12	R/WN high from CLK high		75		75	ns
65	13	RERUNN setup low before CLK high	30		30		ns
66	13	RERUNN hold low from CLK high	20		20		ns
67	13	A1 - A23 to idle state from CLK low		100		100	ns
68	13	A1 - A23 to valid after CLK low		85		85	ns



# Direct Memory Access Interface (DMAI)

# SCB68430

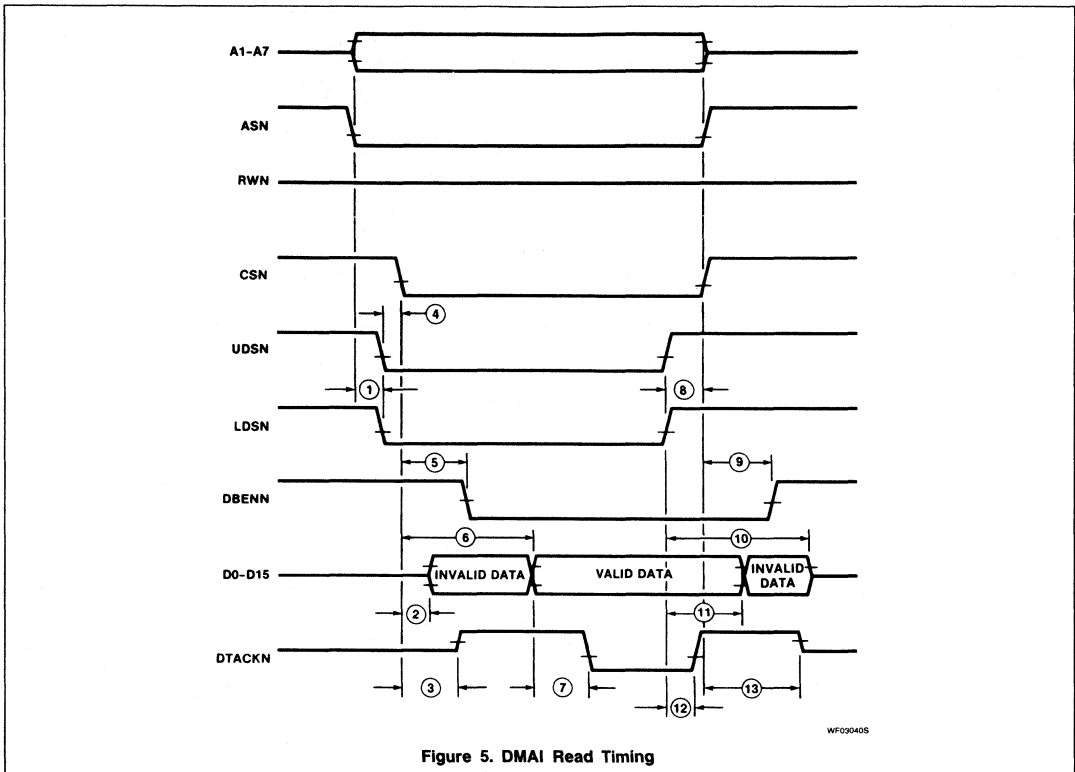

Direct Memory Access Interface (DMAI)

SCB68430

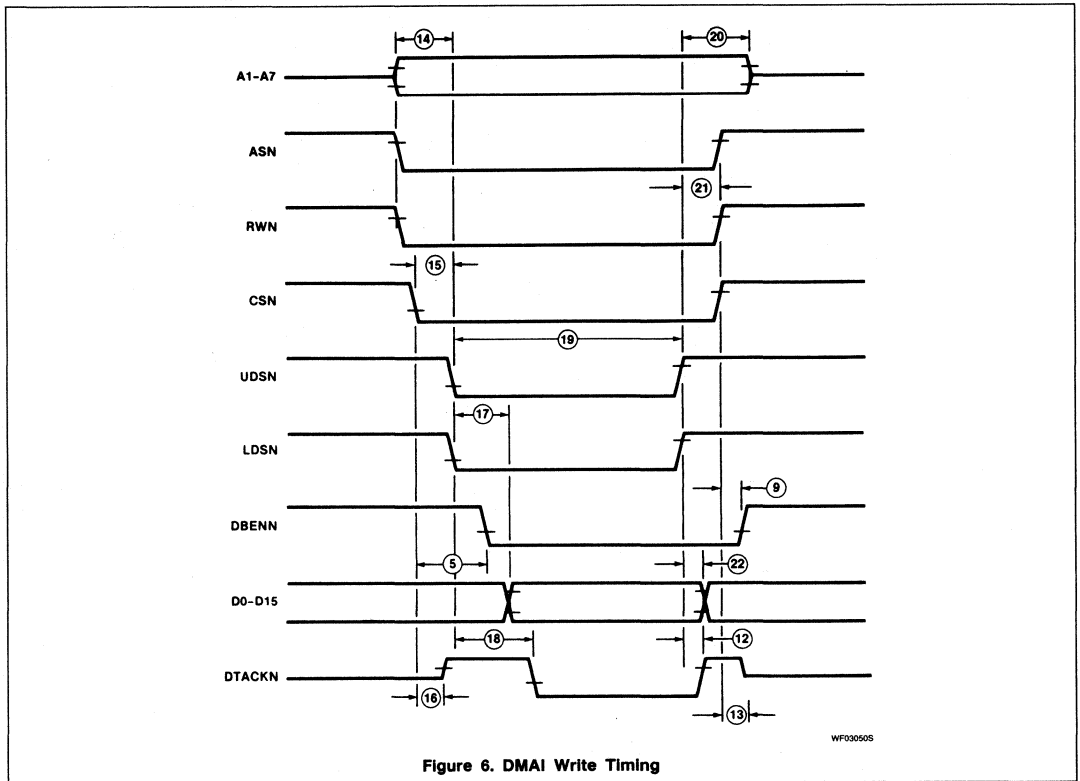
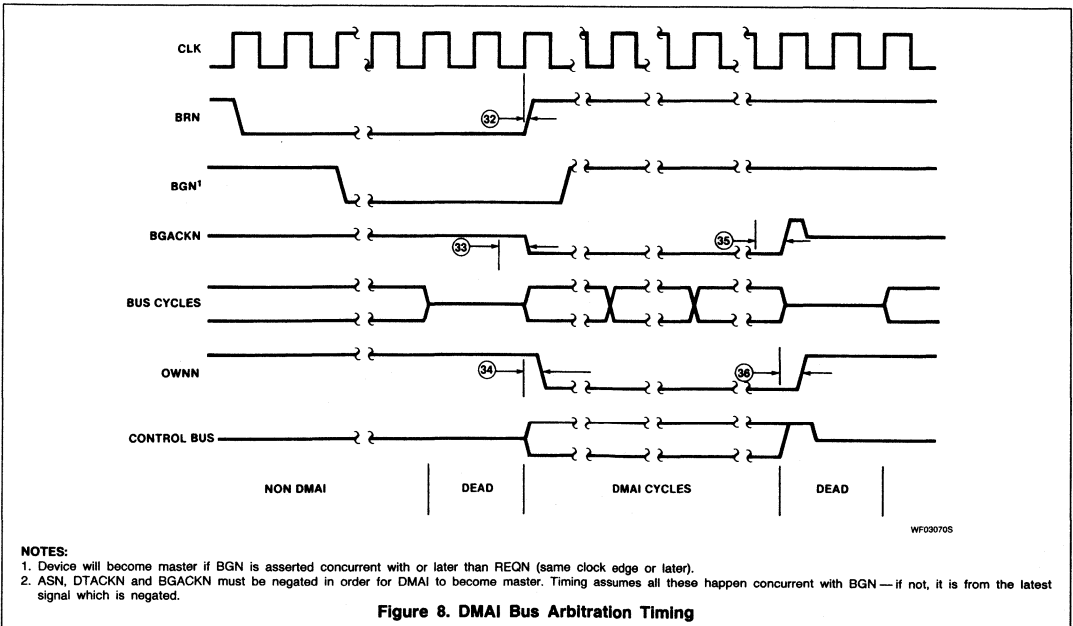
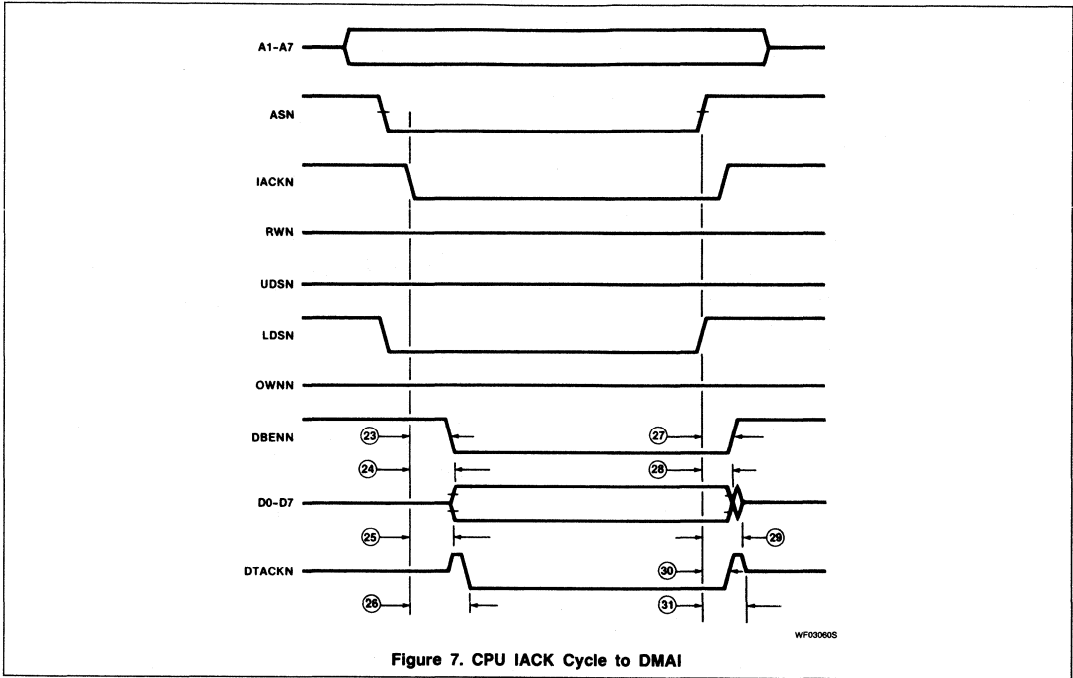

Figure 6. DMAI Write Timing

# Direct Memory Access Interface (DMAI)

SCB68430



**NOTES:**

1. Device will become master if BGN is asserted concurrent with or later than REQN (same clock edge or later).
2. ASN, DTACKN and BGACKN must be negated in order for DMAI to become master. Timing assumes all these happen concurrent with BGN—if not, it is from the latest signal which is negated.

Direct Memory Access Interface (DMAI)

SCB68430

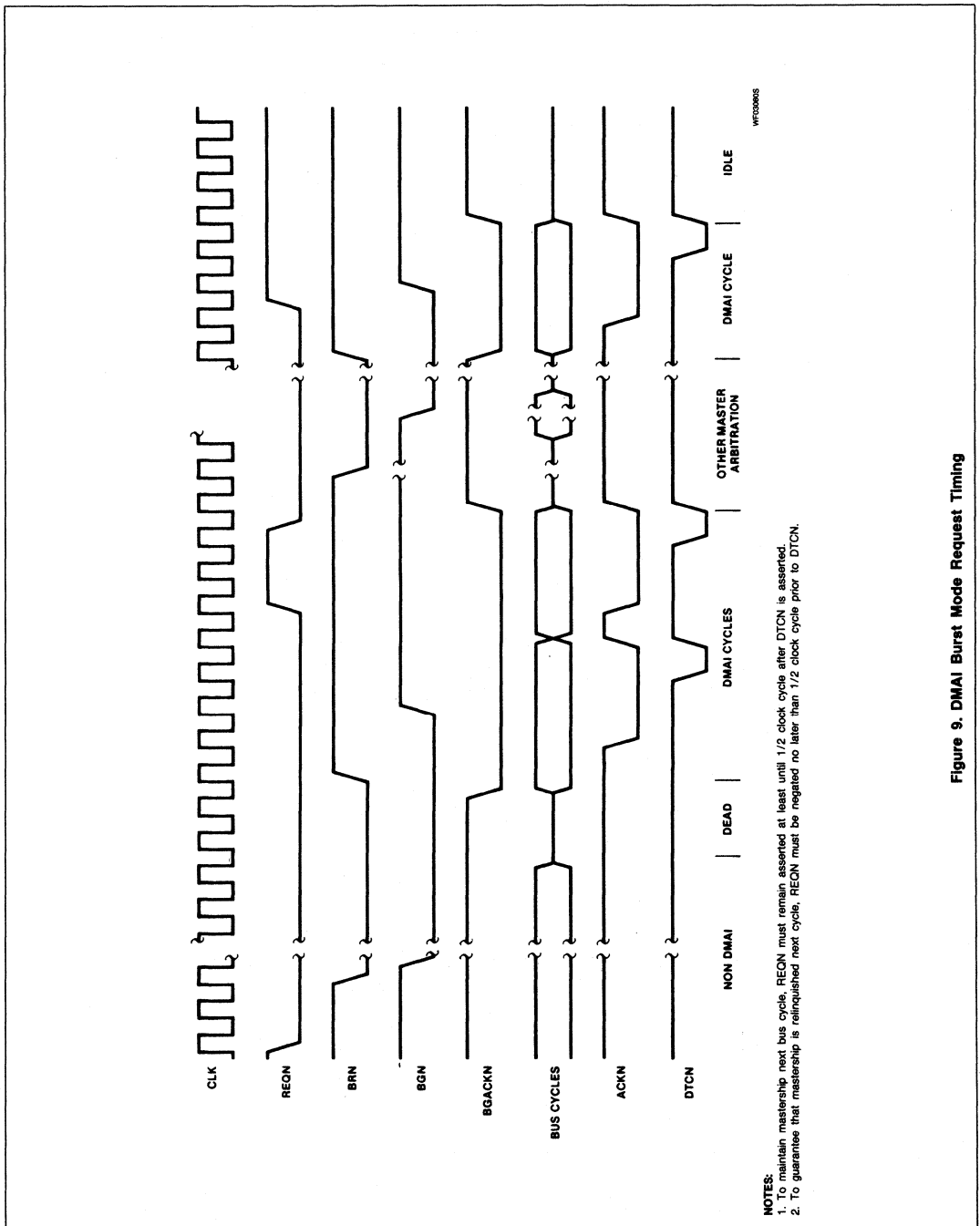
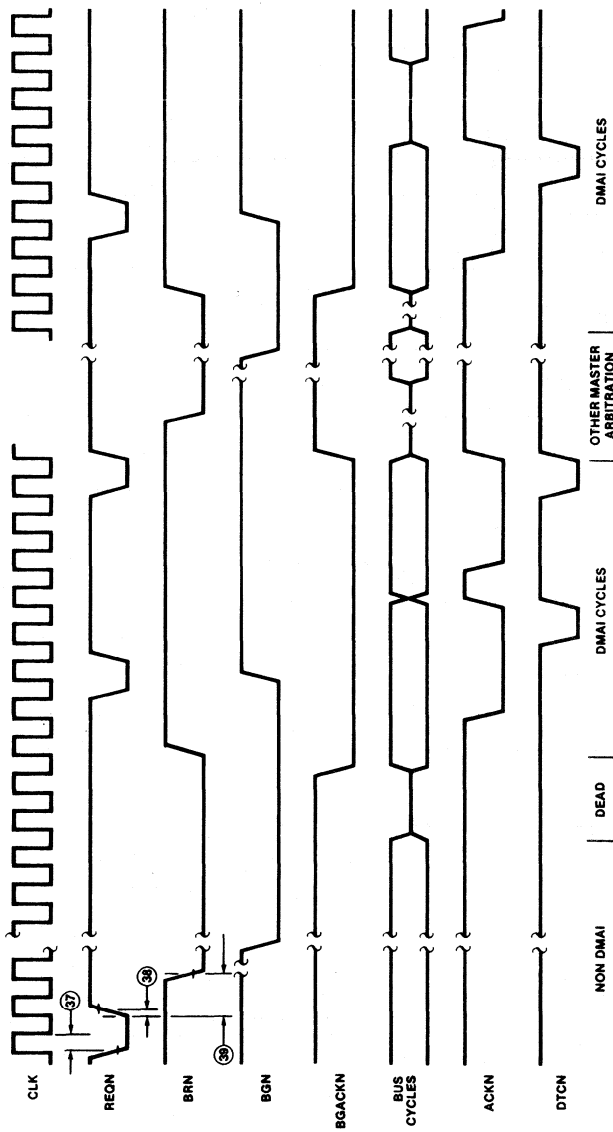

Figure 9. DMAI Burst Mode Request Timing

# Direct Memory Access Interface (DMAI)

## SCB68430



WFO0068

**NOTE:** In order to keep the bus, REQN must come no later than the 1/2 clock minus the setup time  $t_{s1}$  prior to assertion edge of DTGN.

Figure 10. DMAI Cycle Steal Mode Request Timing

Direct Memory Access Interface (DMAI)

SCB68430

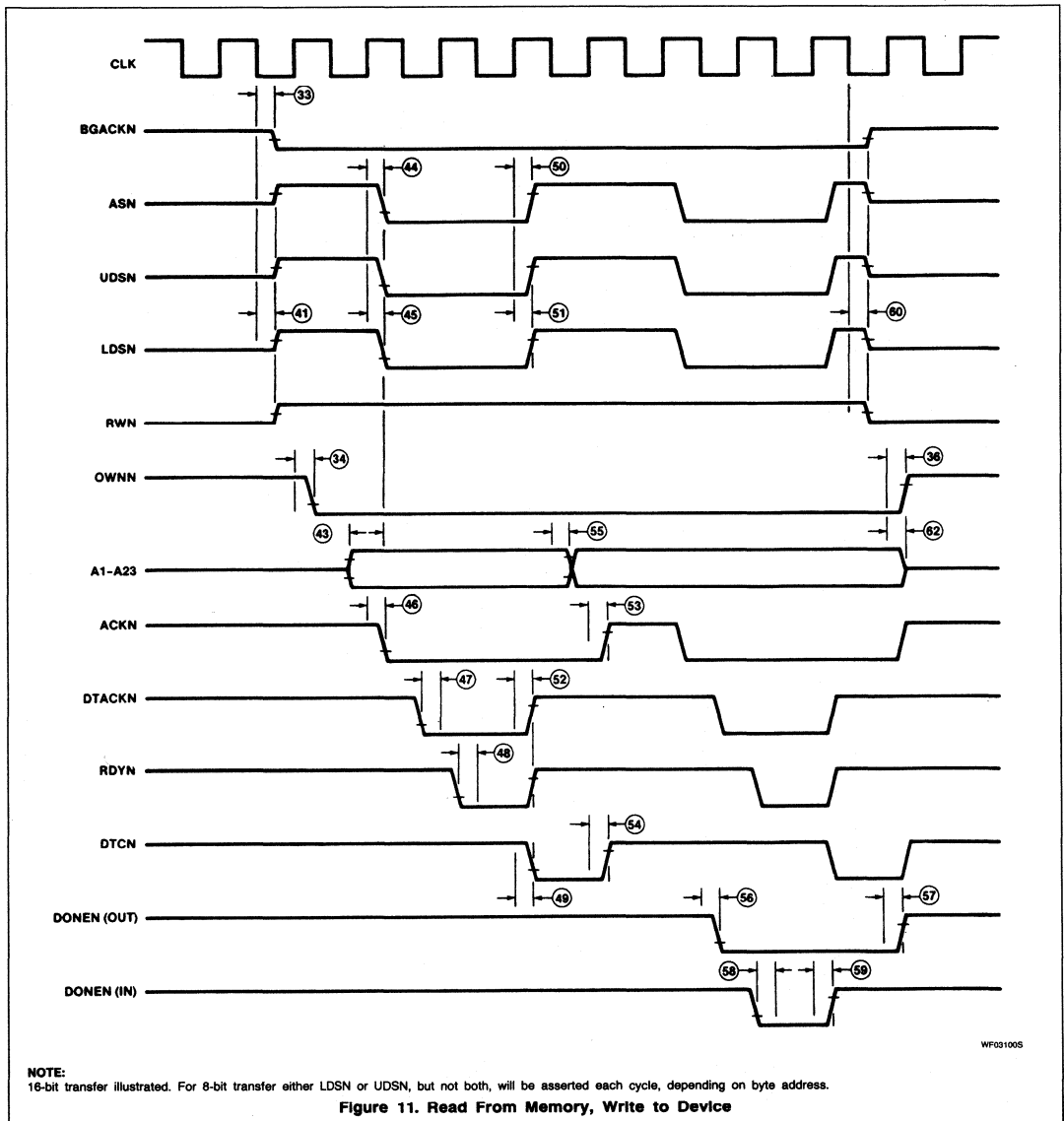

Direct Memory Access Interface (DMAI)

SCB68430

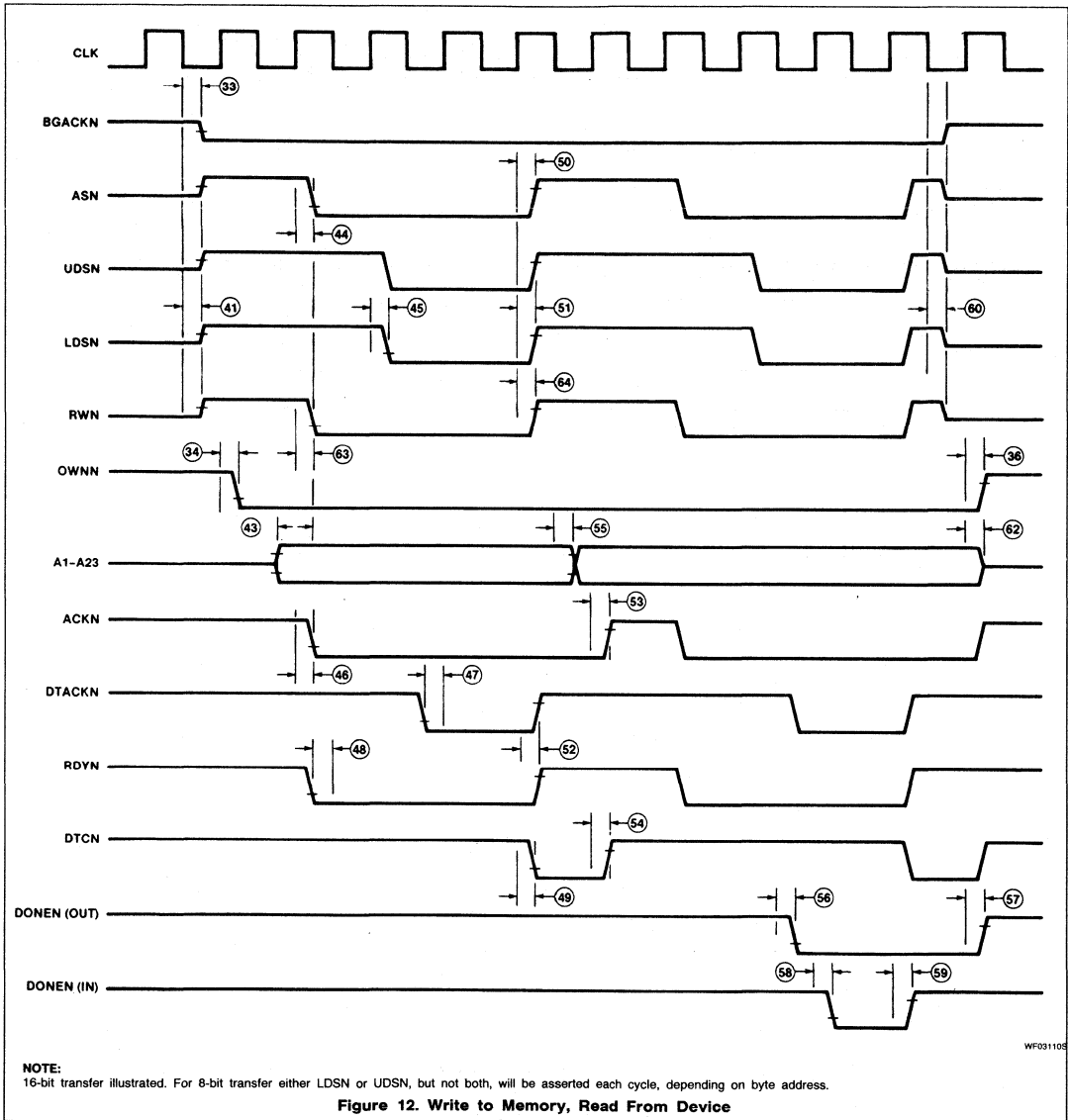

Direct Memory Access Interface (DMAI)

SCB68430

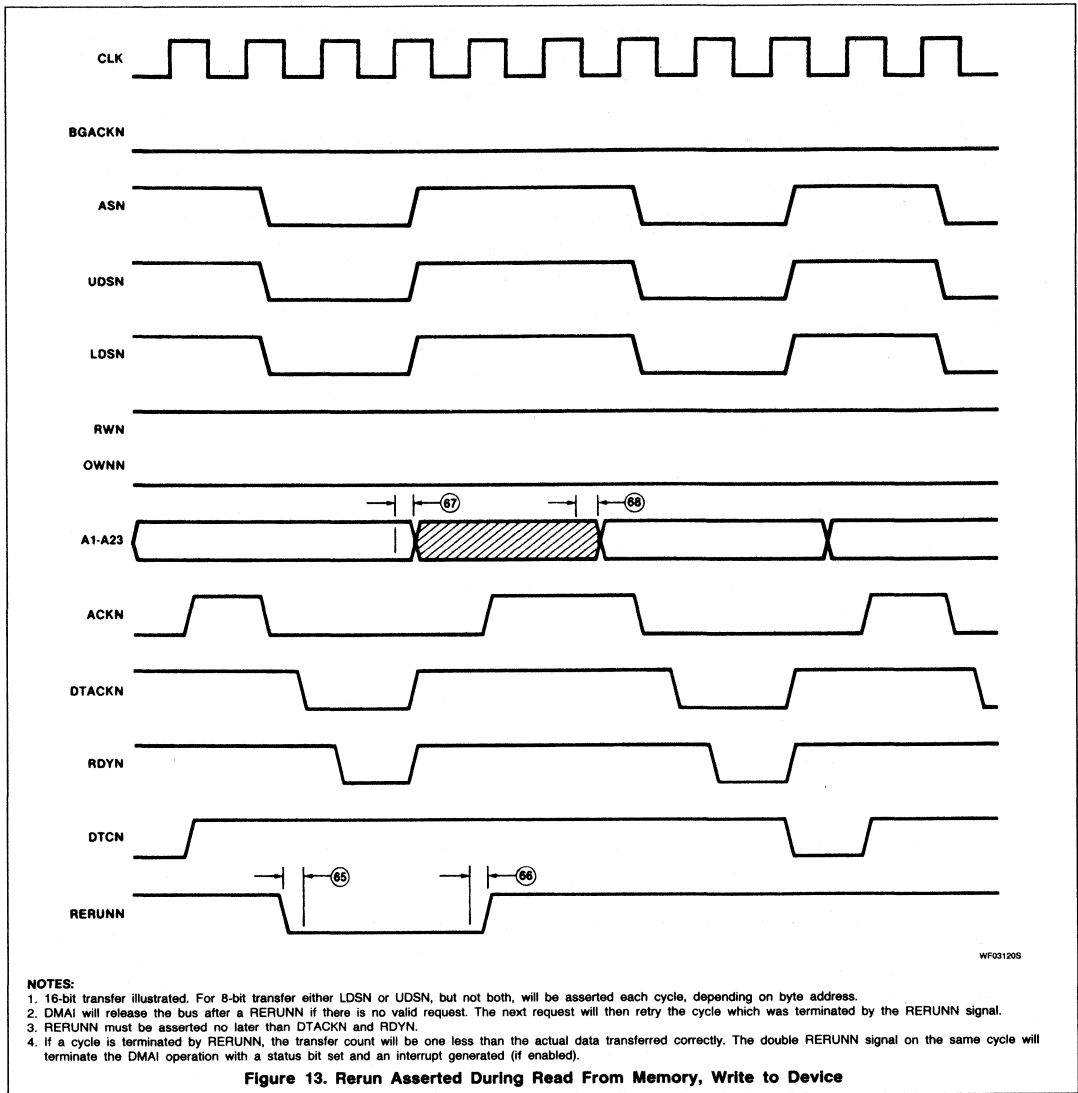



# SCN68562

## Dual Universal Serial Communications Controller (DUSCC)

Microprocessor Products

Preliminary Specification

2

### DESCRIPTION

The Signetics SCN68562 Dual Universal Serial Communications Controller (DUSCC) is a single-chip MOS-LSI communications device that provides two independent, multi-protocol, full-duplex receiver/transmitter channels in a single package. It supports bit-oriented and character-oriented (byte count and byte control) synchronous data link controls as well as asynchronous protocols. The SCN68562 interfaces to the 68000 MPU via asynchronous bus control signals and is capable of program-pollled, interrupt-driven, block-move or DMA data transfers.

The operating mode and data format of each channel can be programmed independently. Each channel consists of a receiver, a transmitter, a 16-bit multi-function counter/timer, a digital phase-locked loop (DPLL), a parity/CRC generator and checker, and associated control circuits. The two channels share a common bit rate generator (BRG), operating directly from a crystal or an external clock, which provides sixteen common bit rates simultaneously. The operating rate for the receiver and transmitter of each channel can be independently selected from the BRG, the DPLL, the counter/timer, or from an external  $1\times$  or  $16\times$  clock, making the DUSCC well suited for dual-speed channel applications. Data rates up to 4Mbits are supported.

The transmitter and receiver each contain a four-deep FIFO with appended transmitter command and receiver status bits and a shift register. This permits

### PIN CONFIGURATIONS

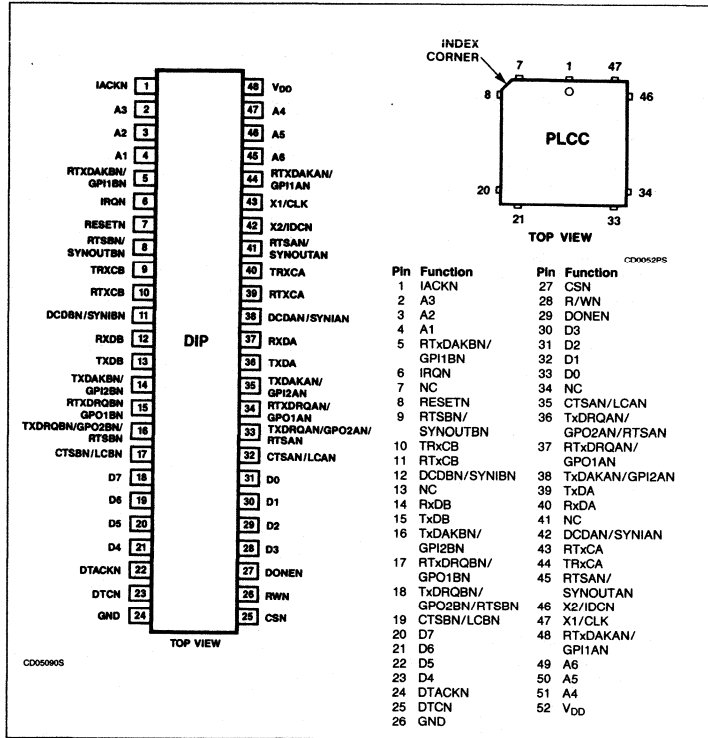

reading and writing of up to four characters at a time, minimizing the potential of receiver overrun or transmitter underrun, and reducing interrupt or DMA overhead. In addition, a flow control capability is provided to disable a remote transmitter when the FIFO of the local receiving device is full.

Two modem control inputs (DCD and CTS) and three modem control outputs (RTS and two general purpose) are provided. Because the modem control inputs and outputs are general purpose in nature, they can be optionally programmed for other functions.

# Dual Universal Serial Communications Controller (DUSCC)      SCN68562

## FEATURES

### General Features

- Dual full-duplex synchronous/asynchronous receiver and transmitter
- Multi-protocol operation
  - BOP: HDLC/ADCCP, SDLC, SDLC loop, X.25 or X.75 link level, e tc.
  - COP: BISYNC, DDCMP, X.21
  - ASYNC: 5 - 8 bits plus optional parity
- Four character receiver and transmitter FIFOs
- 0 to 4MHz data rate
- Programmable bit rate for each receiver and transmitter selectable from:
  - 16 fixed rates: 50 to 38.4k baud
  - One user-defined rate derived from programmable counter/timer
  - External 1X or 16X clock
  - Digital phase-locked loop
- Parity and FCS (frame check sequence LRC or CRC) generation and checking
- Programmable data encoding/decoding: NRZ, NRZI, FMO, FM1, Manchester
- Programmable channel mode: full-half-duplex, auto-echo, or local loopback
- Programmable data transfer mode: polled, interrupt, DMA, wait
- DMA interface
  - Compatible with Signetics' SCB68430 Direct Memory Access Interface (DMAI) and other DMA controllers
  - Half- or full-duplex operation
  - Single or dual address data transfers
  - Automatic frame termination on counter/timer terminal count or DMA DONE
- Interrupt capabilities
  - Daisy chain option
  - Vector output (fixed or modified by status)
  - Programmable internal priorities

- Maskable interrupt conditions
- 68000 compatible
- Multi-function programmable 16-bit counter/timer
  - Bit rate generator
  - Event counter
  - Count received or transmitted characters
  - Delay generator
  - Automatic bit length measurement
- Modem controls
  - RTS, CTS, DCD, and up to four general purpose I/O pins per channel
  - CTS and DCD programmable auto-enables for Tx and Rx
  - Programmable interrupt on change of CTS or DCD
- On-chip oscillator for crystal
- TTL compatible
- Single +5V power supply

### Asynchronous Mode Features

- Character length: 5 to 8 bits
- Odd or even parity, no parity, or force parity
- Up to two stop bits programmable in  $\frac{1}{16}$ - bit increments
- 1X or 16X Rx and Tx clock factors
- Parity, overrun, and framing error detection
- False start bit detection
- Start bit search  $\frac{1}{2}$  bit time after framing error detection
- Break generation with handshake for counting break characters
- Detection of start and end of received break
- Character compare with optional interrupt on match

### Character-Oriented Protocol Features

- Character length: 5 to 8 bits
- Odd or even parity, no parity, or force parity
- LRC or CRC generation and checking
- Optional opening PAD transmission

- One or two SYN characters
- External sync capability
- SYN detection and optional stripping
- SYN or MARK linefill on underrun
- Idle in MARK or SYNs
- Parity, FCS, overrun, and underrun error detection
- BISYNC Features
  - EBDCIC or ASCII header, text and control messages
  - SYN, DLE stripping
  - EOM (end of message) detection and transmission
  - Auto transparency mode switching
  - Auto hunt after receipt of EOM sequence (with closing PAD check after EOT or NAK)
  - Control character sequence detection for both transparent and normal text

### Bit-Oriented Protocol Features

- Character length: 5 to 8 bits
- Detection and transmission of residual character: 0 - 7 bits
- Automatic switch to programmed character length for I field
- Zero insertion and deletion
- Optional opening PAD transmission
- Detection and generation of FLAG, ABORT, and IDLE bit patterns
- Detection and generation of shared (single) FLAG between frames
- Detection of overlapping (shared zero) FLAGS
- ABORT, ABORT-FLAGS, or FCS-FLAGS line fill on underrun
- Idle in MARK or FLAGS
- Secondary address recognition including group and global address
- Single- or dual-octet secondary address
- Extended address and control fields
- Short frame rejection for receiver
- Detection and notification of received end of message
- CRC generation and checking
- SDLC loop mode capability

## ORDERING INFORMATION

PACKAGES	V <sub>CC</sub> = +5V ± 5%, T <sub>A</sub> = 0 to +70°C
Ceramic DIP	SCN68562C4I48
Plastic DIP	SCN68562C4N48
Plastic LCC	SCN68562C4A52

# Dual Universal Serial Communications Controller (DUSCC)

SCN68562

## BLOCK DIAGRAM

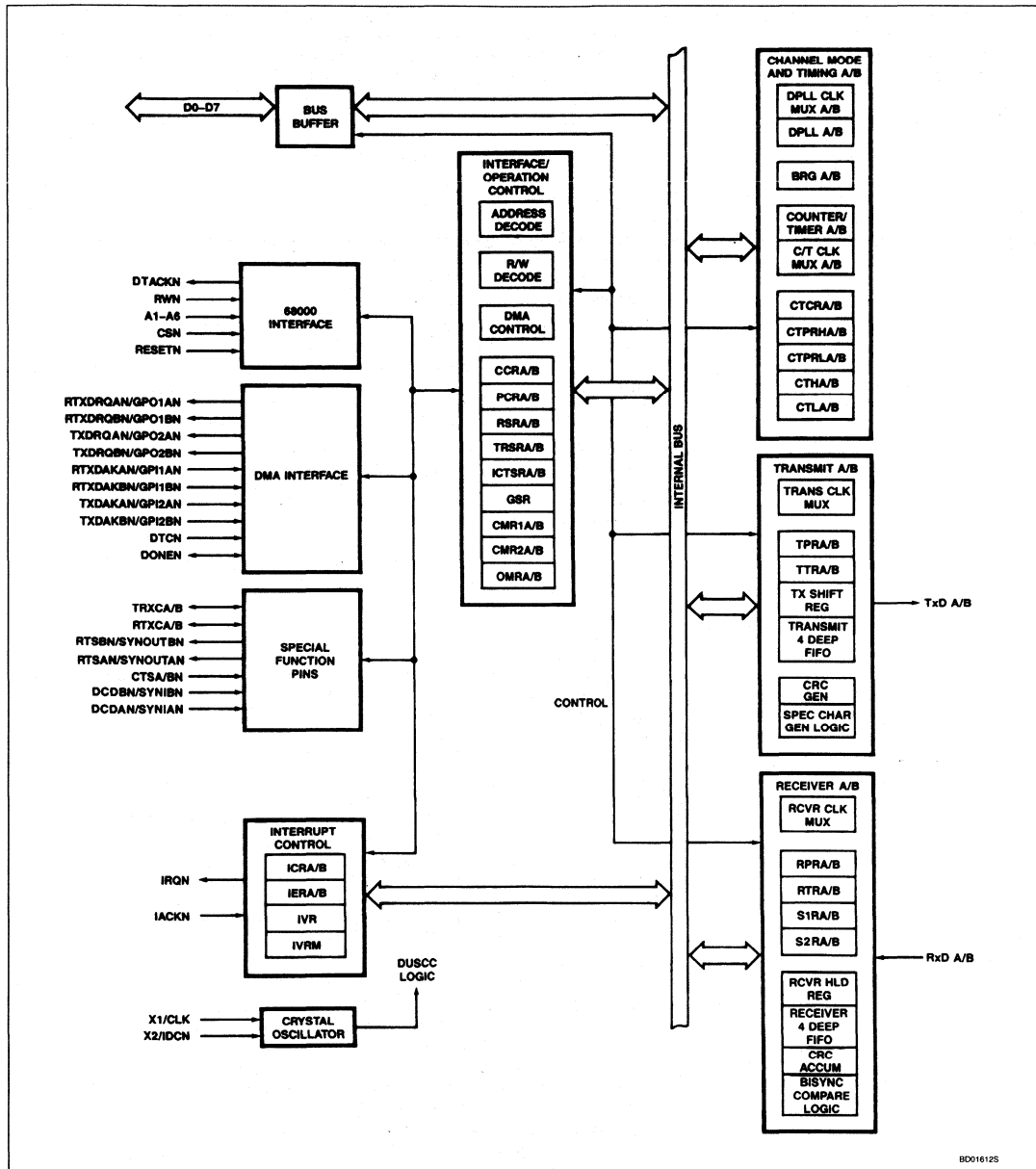

B0016125

## Dual Universal Serial Communications Controller (DUSCC)

SCN68562

## PIN DESCRIPTION

In this data sheet, signals are discussed using the terms 'active' and 'inactive' or 'asserted' and 'negated' independent of whether the signal is active in the high (logic 1) or low (logic 0) state. N at the end of a pin name signifies the signal associated with the pin is active low (see individual pin description for the definition of the active level of each signal.) Pins which are provided for both channels are designated by either an underline (    ) or by A/B after the name of the pin and the active low state indicator, N, if applicable. A similar method is used for registers provided for both channels; these are designated by either an underline or by A/B after the name.

MNEMONIC	PIN NO.		TYPE	NAME AND FUNCTION
	DIP	PLCC		
A1 – A6	4 – 2, 45 – 47	5 – 3, 51 – 49	I	<b>Address Lines:</b> Active high. Address inputs which specify which of the internal registers is accessed for read/write operations.
D0 – D7	31 – 28, 21 – 18	34 – 31, 23 – 20	I/O	<b>Bidirectional Data Bus:</b> Active high, three state. Bit 0 is the LSB and bit 7 is the MSB. All data, command, and status transfers between the CPU and the DUSCC take place over this bus. The data bus is enabled when CSN is low, during interrupt acknowledge cycles and single-address DMA acknowledge cycles.
R/WN	26	29	I	<b>Read/Write:</b> A high input indicates a read cycle and a low input indicates a write cycle when a cycle is initiated by assertion of the CSN input.
CSN	25	28	I	<b>Chip Select:</b> Active low input. When low, data transfers between the CPU and the DUSCC are enabled on D0 – D7 as controlled by the R/WN and A1 – A6 inputs. When CSN is high, the DUSCC is isolated from the data bus (except during interrupt acknowledge cycles and single-address DMA transfers) and D0 – D7 are placed in the tri-state condition.
DTACKN	22	24	O	<b>Data Transfer Acknowledge:</b> Active low, 3-State. DTACKN is asserted on a write cycle to indicate that the data on the bus has been latched, and on a read cycle or interrupt acknowledge cycle to indicate valid data is on the bus. The signal is negated when completion of the cycle is indicated by negation of the CSN or IACKN input, and returns to the inactive state (3-State) a short period after it is negated. In single address DMA mode, the operation of this pin is similar to the description above. The exception is that it is negated when completion of the cycle is indicated by the assertion of DTCN or negation of DMA acknowledge inputs (whichever occurs first), and returns to the inactive state (3-State) a short period after it is negated. When negated, DTACKN becomes an open drain output and requires an external pull-up resistor.
IRQN	6	7	O	<b>Interrupt Request:</b> Active low, open drain. This output is asserted upon occurrence of any enabled interrupting condition. The CPU can read the general status register to determine the interrupting condition(s), or can respond with an interrupt acknowledge cycle to cause the DUSCC to output an interrupt vector on the data bus.
IACKN	1	2	I	<b>Interrupt Acknowledge:</b> Active low. When IACKN is asserted, the DUSCC responds by placing the contents of the interrupt vector register (modified or unmodified by status) on the data bus and asserting DTACKN. If no active interrupt is pending, DTACKN is not asserted.
X1/CLK	43	47	I	<b>Crystal or External Clock:</b> When using the crystal oscillator, the crystal is connected between pins X1 and X2. If a crystal is not used, an external clock is supplied at this input. This clock is used to drive the internal bit rate generator, as an optional input to the counter/timer or DPLL, and to provide other required clocking signals.
X2/IDCN	42	46	O	<b>Crystal or Interrupt Daisy Chain:</b> Active low. When a crystal is used as the timing source, the crystal is connected between pins X1 and X2. This pin can be programmed to provide an interrupt daisy chain output which propagates the IACKN signal to lower priority devices, if no active interrupt is pending. This pin should be grounded when an external clock is used on X1 and X2, is not used as an interrupt daisy chain output.
RESETN	7	8	I	<b>Master Reset:</b> Active low. A low on this pin resets the transmitters and receivers and resets the registers shown in Table 1. Reset is asynchronous, i.e., no clock is required.
RxDA, RxDB	37, 12	41, 13	I	<b>Channel A (B) Receiver Serial Data Input:</b> The least significant bit is received first. If external receiver clock is specified for the channel, the input is sampled on the rising edge of the clock.
TxDA, TxDB	36, 13	39, 15	O	<b>Channel A (B) Transmitter Serial Data Output:</b> The least significant bit is transmitted first. This output is held in the marking (high) condition when the transmitter is disabled or when the channel is operating in local loopback mode. If external transmitter clock is specified for the channel, the data is shifted on the falling edge of the clock.
RTxCA, RTxCB	39, 10	43, 11	I/O	<b>Channel A (B) Receiver/Transmitter Clock:</b> As an input, it can be programmed to supply the receiver, transmitter, counter/timer, or DPLL clock. As an output, can supply the counter/timer output, the transmitter shift clock (1×), or the receiver sampling clock (1×). The maximum external receiver/transmitter clock frequency is 4MHz.

## Dual Universal Serial Communications Controller (DUSCC)

SCN68562

## PIN DESCRIPTION (Continued)

MNEMONIC	PIN NO.		TYPE	NAME AND FUNCTION
	DIP	PLCC		
TRxCA, TRxCB	40, 9	44, 10	I/O	<b>Channel A (B) Transmitter/Receiver Clock:</b> As an input, it can supply the receiver, transmitter, counter/timer, or DPLL clock. As an output, it can supply the counter/timer output, the DPLL output, the transmitter shift clock (1X), the receiver sampling clock (1X.), the transmitter BRG clock (16X), the receiver BRG clock (16X), or the internal system clock (X/2). The maximum external receiver/transmitter clock frequency is 4MHz.
CTS <sub>A</sub> /BN, LCA <sub>A</sub> /BN	32, 17	35, 19	I/O	<b>Channel A (B) Clear-To-Send input or Loop Control Output:</b> Active low. The signal can be programmed to act as an enable for the transmitter when not in loop mode. The DUSCC detects logic level transitions on this input and can be programmed to generate an interrupt when a transition occurs. When operating in the BOP loop mode, this pin becomes a loop control output which is asserted and negated by DUSCC commands. This output provides the means of controlling external loop interface hardware to go on-line and off-line without disturbing operation of the loop.
DCDA <sub>A</sub> /BN, SYNIA <sub>A</sub> /BN	38, 11	42, 12	I	<b>Channel A (B) Data Carrier Detected or External Sync Input:</b> The function of this pin is programmable. As a DCD active low input, it acts as an enable for the receiver or can be used as a general purpose input. For the DCD function, the DUSCC detects logic level transitions on this input and can be programmed to generate an interrupt when a transition occurs. As an active low external sync input, it is used in COP modes to obtain character synchronization without receipt of a SYN or FLAG character. This mode can be used in disc or tape controller applications or for the optional byte timing lead in X.21.
RTxDRQA <sub>A</sub> /BN, GPO1A <sub>A</sub> /BN	34, 15	37, 17	O	<b>Channel A (B) Receiver/Transmitter DMA Service Request or General Purpose Output:</b> Active low. For half-duplex DMA operation, this output indicates to the DMA controller that one or more characters are available in the receiver FIFO (when the receiver is enabled) or that the transmit FIFO is not full (when the transmitter is enabled). For full-duplex DMA operation, this output indicates to the DMA controller that data is available in the receiver FIFO. In non-DMA mode, this pin is a general purpose output that can be asserted and negated under program control.
TxDRQA <sub>A</sub> /BN, GPO2A <sub>A</sub> /BN, RTSA <sub>A</sub> /BN	33, 16	36, 18	O	<b>Channel A (B) Transmitter DMA Service Request, General Purpose Output, or Request-to-Send:</b> Active low. For full-duplex DMA operation, this output indicates to the DMA controller that the transmit FIFO is not full and can accept more data. When not in full-duplex DMA mode, this pin can be programmed as a general purpose or a Request-to-Send output, which can be asserted and negated under program control (see Detailed Operation).
RTxDAKA <sub>A</sub> /BN, GPI1A <sub>A</sub> /BN	44, 5	48, 6	I	<b>Channel A (B) Receiver/Transmitter DMA Acknowledge or General Purpose Input:</b> Active low. For half-duplex single address DMA operation, this input indicates to the DUSCC that the DMA controller has acquired the bus and that the requested bus cycle (read receiver FIFO or load transmitter FIFO) is beginning. For full-duplex single address DMA operation, this input indicates to the DUSCC that the DMA controller has acquired the bus and that the requested read receiver FIFO bus cycle is beginning. Because the state of this input can be read under program control, it can be used as a general purpose input when not in single address DMA mode.
TxDAKA <sub>A</sub> /BN, GPI2A <sub>A</sub> /BN	35, 14	38, 16	I	<b>Channel A (B) Transmitter DMA Acknowledge or General Purpose Input:</b> Active low. When the channel is programmed for full-duplex single address DMA operation, this input is asserted to indicate to the DUSCC that the DMA controller has acquired the bus and that the requested load transmitter FIFO bus cycle is beginning. Because the state of this input can be read under program control, it can be used as a general purpose input when not in full-duplex single address DMA mode.
DTCN	23	25	I	<b>Device Transfer Complete:</b> Active low. DTCN is asserted by the DMA controller to indicate that the requested data transfer is complete.
DONEN	27	30	I/O	<b>Done:</b> Active low, open drain. See Detailed Operation for a description of the function of this pin.
RTSA <sub>A</sub> /BN, SYNOUTA <sub>A</sub> /BN	41, 8	45, 9	O	<b>Channel A (B) Sync Detect or Request-to-Send:</b> Active low. If programmed as a sync output, it is asserted one bit time after the specified sync character (COP or BISYNC modes) or a FLAG (BOP modes) is detected by the receiver. As a Request-to-Send modem control signal, it functions as described previously for the TxDRQ <sub>N</sub> /RTS <sub>N</sub> pin.
V <sub>DD</sub>	48	52	I	+5V ±5% power input.
GND	24	26	I	Signal and power ground input.

2

# Dual Universal Serial Communications Controller (DUSCC)      SCN68562

## REGISTERS

The addressable registers of the DUSCC are shown in Table 1. The following rules apply to all registers:

1. A read from a reserved location in the map results in a read from the 'null register'. The null register returns all ones for data and results in a normal bus cycle. A write to one of these locations results in a normal bus cycle without a write being performed.
2. Unused bits of a defined register are read as zeros, unless ones have been loaded after master reset.
3. Bits that are unused in the chosen mode but are used in others are readable and writable but their contents are ignored in the chosen mode.
4. All registers are addressable as 8-bit quantities. To facilitate operation with the 68000 MOVEP instruction, addresses are ordered such that certain sets of registers may also be accessed as words or long words.

The operation of the DUSCC is programmed by writing control words into the appropriate registers. Operational feedback is provided via status registers which can be read by the CPU. The contents of certain control registers are initialized on RESET (set to zero). Care should be exercised if the contents of a register are changed during operation, since certain changes may cause operational problems, e.g., changing the channel mode at an inappropriate time may cause the reception or transmission of an incorrect character. In general, the contents of registers which control transmitter or receiver operation, or the counter/timer, should be changed only when they are not enabled.

The DUSCC registers can be separated into five groups to facilitate their usage:

1. Channel mode configuration and pin description registers
2. Transmitter and receiver parameter and timing registers
3. Counter/timer control and value registers
4. Interrupt control and status registers
5. Command register

This arrangement is used in the following description of the DUSCC registers.

### Channel Mode Configuration and Pin Description Registers

There are five registers in this group for each channel. The bit format for each of these registers is contained in Table 2. The primary function of these registers is to define configuration of the channels and the function of the programmable pins.

### Channel Mode Register 1 (CMR1A, CMR1B)

**[7:6] Data Encoding** — These bits select the data encoding for the received and transmitted data:

- 00 If the DPLL is set to NRZI mode (see DPLL commands), it selects positive logic (1 = high, 0 = low). If the DPLL is set to FM mode (see DPLL commands), Manchester (bi-phase level) encoding is selected.
- 01 NRZI. Non-return-to-zero inverted.
- 10 FM0. Bi-phase space.
- 11 FM1. Bi-phase mark.

**[5] Extended Control (BOP)** —

- 0 No. A one-octet control field follows the address field.
- 1 Yes. A two-octet control field follows the address field.

**[5] Parity (COP/ASYN), Code Select (BISYN)** —

- 0 Even parity if with parity is selected by [4:3] or a 0 in the parity bit position if force parity is selected by [4:3]. In BISYN protocol mode, internal character comparisons are made using EBCDIC coding.
- 1 Odd parity if with parity is selected by [4:3] or a 1 in the parity bit position if force parity is selected by [4:3]. In BISYN protocol mode, internal character comparisons are made using 8-bit odd parity ASCII coding. (Note: The receiver should be programmed for 8-bit characters, RPR[1:0] = 11, with no parity, CMR1[4:3] = 00.)

**[4:3] Address Mode (BOP)** — This field controls whether a single octet or multiple octets follow the opening FLAG(s) for both the receiver and the transmitter. This field is activated by selection of BOP secondary mode through the channel protocol mode bits CMR1\_[2:0] (see Detailed Operation).

- 00 Single-octet address.
- 01 Extended address.
- 10 Dual-octet address.
- 11 Dual-octet address with group.

**[4:3] Parity Mode (COP/ASYN)** — This field selects the parity mode for both the receiver and the transmitter. A parity bit is added to the programmed character length if with parity or force parity is selected:

- 00 No parity. Required when BISYN protocol mode is programmed.
- 01 Reserved.
- 10 With parity. Odd or even parity is selected by [5].
- 11 Force parity. The parity bit is forced to the state selected by [5].

**[2:0] Channel Protocol Mode** — This field selects the operational protocol and sub-mode for both the receiver and transmitter:

- 000 BOP Primary. No address comparison is performed. For receive, all characters received after the opening FLAG(s) are transferred to the FIFO.
- 001 BOP Secondary. This mode activates the address modes selected by [4:3]. Except in the case of extended address ([4:3]=01), an address comparison is performed to determine if a frame should be received. Refer to Detailed Operation for details of the various addressing modes. If a valid comparison occurs, the receiver is activated and the address octets and all subsequent received characters of the frame are transferred to the receive FIFO.
- 010 BOP Loop. The DUSCC acts as a secondary station in a loop. The GO-ON-LOOP and GO-OFF-LOOP commands are used to cause the DUSCC to go on and off the loop. Normally, the TxD output echoes the RxD input with a two-bit time delay. If the transmitter is enabled and the 'go active on poll' command has been asserted, the transmitter will begin sending when an EOP sequence consisting of a zero followed by seven ones is detected. The DUSCC changes the last one of the EOP to zero, making it another FLAG, and then operates as described in the detailed operation section. The loop sending status bit (TRSR[6]) is asserted concurrent with the beginning of transmission. The frame should normally be terminated with an EOM followed by an echo of the marking RxD line so that secondary stations further down the loop can append their messages to the messages from up-loop stations by the same process. If the 'go active on poll' command is not asserted, the transmitter remains inactive (other than echoing the received data) even when the EOP sequence is received.
- 011 BOP Loop without address comparison. Same as normal loop mode except that address field comparisons are disabled. All received frames are transmitted to the CPU.
- 100 COP Dual SYN. Character sync is achieved upon receipt of a bit sequence matching the contents of the appropriate bits of S1R and S2R (SYN1-SYN2), including parity bits if any.
- 101 COP Dual SYN (BISYN). Character sync is achieved upon receipt of a bit

# Dual Universal Serial Communications Controller (DUSCC)

SCN68562

**Table 1. DUSCC Register Address Map**

ADDRESS BITS <sup>1</sup> 6 5 4 3 2 1	ACRONYM	REGISTER NAME	MODE	AFFECTED BY RESET
c 0 0 0 0 0	CMR1	Channel Mode Register 1	R/W	Yes — 00
c 0 0 0 0 1	CMR2	Channel Mode Register 2	R/W	Yes — 00
c 0 0 0 1 0	S1R	SYN 1/Secondary Address 1 Register	R/W	No
c 0 0 0 1 1	S2R	SYN 2/Secondary Address 2 Register	R/W	No
c 0 0 1 0 0	TPR	Transmitter Parameter Register	R/W	Yes — 00
c 0 0 1 0 1	TTR	Transmitter Timing Register	R/W	No
c 0 0 1 1 0	RPR	Receiver Parameter Register	R/W	Yes — 00
c 0 0 1 1 1	RTR	Receiver Timing Register	R/W	No
c 0 1 0 0 0	CTPRH	Counter/Timer Preset Register High	R/W	No
c 0 1 0 0 1	CTPRL	Counter/Timer Preset Register Low	R/W	No
c 0 1 0 1 0	CTCR	Counter/Timer Control Register	R/W	Yes — 00
c 0 1 0 1 1	OMR	Output and Miscellaneous Register	R/W	Yes — 00
c 0 1 1 0 0	CTH	Counter/Timer High	R	No
c 0 1 1 0 1	CTL	Counter/Timer Low	R	No
c 0 1 1 1 0	PCR	Pin Configuration Register	R/W	Yes — 00
c 0 1 1 1 1	CCR	Channel Command Register	R/W	No
c 1 0 0 X X	TxFIFO	Transmitter FIFO	W	No
c 1 0 1 X X	RxFIFO	Receiver FIFO	R	No
c 1 1 0 0 0	RSR	Receiver Status Register	R/W <sup>2</sup>	Yes — 00
c 1 1 0 0 1	TRSR	Transmitter and Receiver Status Register	R/W <sup>2</sup>	Yes — 00
c 1 1 0 1 0	ICTSR	Input and Counter/Timer Status Register	R/W <sup>2</sup>	Yes
d 1 1 0 1 1	GSR	General Status Register	R/W <sup>2</sup>	Yes — 00
c 1 1 1 0 0	IER	Interrupt Enable Register	R/W	Yes — 00
c 1 1 1 0 1		Not used		
0 1 1 1 1 0	IVR	Interrupt Vector Register — Unmodified	R/W	Yes — 0F
1 1 1 1 1 0	IVRM	Interrupt Vector Register — Modified	R	Yes — 0F
0 1 1 1 1 1	ICR	Interrupt Control Register	R/W	Yes — 00
1 1 1 1 1 1		Not used		

**NOTES:**

- c = 0 for channel A, c = 1 for channel B.  
d = don't care — register may be accessed as either channel.  
x = don't care — FIFOs are addressable at any of four adjacent addresses to allow them to be addressed as byte/word/long word with the 6800 MOVEP instruction.
- A write to this register may perform a status resetting operation.

- sequence matching the contents of the appropriate bits of S1R and S2R (SYN1-SYN2). In this mode, special transmitter and receive logic is activated. Transmitter and receiver character length must be programmed to 8 bits and no parity (see Detailed Operation).
- 110 COP Single SYN. Character sync is achieved upon receipt of a bit sequence matching the contents of the appropriate bits of S1R (SYN1), including parity bit if any. This mode is required when the external sync mode is selected (see description of RPR[4], BOP/COP).
- 111 Asynchronous. Start/stop format.

**Channel Mode Register 2 (CMR2A, CMR2B)**

**[7:6] Channel Connection** — This field selects the mode of operation of the channel. The user must exercise care when switching into and out of the various modes. The selected mode will be activated immediately upon mode selection, even if this occurs in

- the middle of a received or transmitted character.
- 00 Normal mode. The transmitter and receiver operate independently in either half- or full-duplex, controlled by the respective enable commands.
- 01 Automatic echo mode. Automatically retransmits the received data with a half-bit time delay (ASYN, 16× clock mode) or a two-bit time delay (all other modes). The following conditions are true while in automatic echo mode:
- Received data is reclocked and retransmitted on the TxD output.
  - The receiver clock is used for the transmitter for Async 16X clock mode. For other modes the transmitter clock must be supplied.
  - The receiver must be enabled, but the transmitter need not be enabled.
  - The TxRDY and underrun status bits are inactive.

- The received parity and/or FCS are checked if required, but are not regenerated for transmission, i.e., transmitted parity and/or FCS are as received.
  - In ASYNC mode, character framing is checked, but the stop bits are retransmitted as received. A received break is echoed as received.
  - CPU to receiver communication continues normally, but the CPU to transmitter link is disabled.
- 10 Local loopback mode. In this mode:
- The transmitter output is internally connected to the receiver input.
  - The transmit clock is used for the receiver if NRZI or NRZ encoding is used. For FM or Manchester encoding because the receiver clock is derived from the DPLL, the DPLL source clock must be maintained.
  - The TxD output is held high.

# Dual Universal Serial Communications Controller (DUSCC)      SCN68562

4. The RxD input is ignored.
  5. The receiver and transmitter must be enabled.
  6. CPU to transmitter and receiver communications continue normally.
- 11    Reserved.

**[5:3] Data Transfer Interface** — This field specifies the type of data transfer between the DUSCC's Rx and Tx FIFOs and the CPU. All interrupt and status functions operate normally regardless of the data transfer interface programmed. Refer to Detailed Operation for details of the various DMA transfer interfaces.

- 000    Half-duplex single address DMA.
- 001    Half-duplex dual address DMA.
- 010    Full-duplex single address DMA.
- 011    Full-duplex dual address DMA.
- 100    Wait on receive only. In this mode a read of a non-empty receive FIFO results in a normal bus cycle. However, if the receive FIFO of the channel is empty when a read Rx FIFO cycle is initiated, the DTACKN output remains negated until a character is received and loaded into the FIFO. DTACKN is then asserted and the cycle is completed normally.
- 101    Wait on transmit only. In this mode a write to a non-full transmit FIFO results in a normal bus cycle. However, if the transmit FIFO of the channel is full when a write Tx FIFO cycle is initiated, the DTACKN output remains negated until a FIFO position becomes available for the new character. DTACKN is then asserted and the cycle is completed normally.
- 110    Wait on transmit and receive. As above for both wait on receive and transmit operations.
- 111    Polled or interrupt. DMA and wait functions of the channel are not activated. Data transfers to the Rx and Tx FIFOs are via normal bus read and write cycles in response to polling of the status registers and/or interrupts.

**[2:0] Frame Check Sequence Select** — This field selects the optional frame check sequence (FCS) to be appended at the end of a transmitted frame. When CRC is selected in COP, then no parity and 8-bit character length must be used. The selected FCS is transmitted as follows:

1. Following the transmission of a FIFOed character tagged with the 'send EOM' command.

2. If underrun control (TPR[7:6]) is programmed for TEOM, upon occurrence of an underrun.
3. If TEOM on zero count or done (TPR[4]) is asserted and the counter/timer is counting transmitted characters, after transmission of the character which causes the counter to reach zero count.
4. In DMA mode with TEOM on zero count or done (TPR[4]) set, after transmission of a character if DONEN is asserted when that character was loaded into the Tx FIFO by the DMA controller.

- 000    No frame check sequence.
- 001    Reserved
- 010    LRC8: Divisor =  $x^8 + 1$ , dividend preset to zeros. The Tx sends the calculated LRC non-inverted. The Rx indicates an error if the computed LRC is not equal to 0. Valid for COP modes only.
- 011    LRC8: Divisor =  $x^8 + 1$ , dividend preset to ones. The Tx sends the calculated LRC non-inverted. The Rx indicates an error if the computed LRC is not equal to 0. Valid for COP modes only.
- 100    CRC16: Divisor =  $x^{16} + x^{15} + x^2 + 1$ , dividend preset to zeros. The Tx sends the calculated CRC non-inverted. The Rx indicates an error if the computed CRC is not equal to 0. Not valid for ASYNC mode.
- 101    CRC16: Divisor =  $x^{16} + x^{15} + x^2 + 1$ , dividend preset to ones. The Tx sends the calculated CRC non-inverted. The Rx indicates an error if the computed CRC is not equal to 0. Not valid for ASYNC mode.
- 110    CRC-CCITT: Divisor =  $x^{16} + x^{12} + x^5 + 1$ , dividend preset to zeros. The Tx sends the calculated CRC non-inverted. The Rx indicates an error if the computed CRC is not equal to 0. Not valid for ASYNC mode.
- 111    CRC-CCITT: Divisor =  $x^{16} + x^{12} + x^5 + 1$ , dividend preset to ones. The Tx sends the calculated CRC inverted. The Rx indicates an error if the computed CRC is not equal to H'F0B8'. Not valid for ASYNC mode.

### SYN1/Secondary Address 1 Register (S1RA, S1RB)

**[7:0] Character Compare** — In ASYNC mode this register holds a 5- to 8-bit long bit pattern which is compared with received characters. If a match occurs, the character compare status bit (RSR[7]) is set. This field is ignored if the receiver is in a break condition.

In COP modes, this register contains the 5- to 8-bit SYN1 bit pattern, right justified. Parity bit need not be included in the value placed in the register even if parity is specified in CMR1[4:3]. However, a character received with parity error, when parity is specified, will not match. In ASYNC or COP modes, if parity is specified, then any unused bits in this register must be programmed to zeros. In BOP secondary mode it contains the address used to compare the first received address octet. The register is not used in BOP primary mode or secondary modes where address comparisons are not made, such as when extended addressing is specified.

### SYN2/Secondary Address 2 Register (S2RA, S2RB)

**[7:0]** — This register is not used in ASYNC, COP single SYN, BOP primary modes, BOP secondary modes with single address field, and BOP secondary modes where address comparisons are not made, such as when extended addressing is specified.

In COP dual SYN modes, it contains the 5- to 8-bit SYN2 bit pattern, right justified. Parity bit need not be included in the value placed in the register even if parity is specified in CMR1[4:3]. However, a character received with parity error, when parity is specified, will not match. If parity is specified, then any unused bits in this register must be programmed to zeros. In BOP secondary mode using two address octets, it contains the partial address used to compare the second received address octet.

### Pin Configuration Register (PCRA, PCRB)

This register selects the functions for multi-purpose I/O pins.

**[7] X2/IDC** — This bit is defined only for PCRA. It is not used in PCRB.

- 0    The X2/IDCN pin is used as a crystal connection.
- 1    The X2/IDCN pin is the interrupt daisy chain output.

**[6] GPO2/RTS** — The function of this pin is programmable only when not operating in full-duplex DMA mode.

- 0    The TxDRQ\_N/GPO2\_N/RTS\_N pin is a general purpose output. It is low when OMR[2] is a 1 and high when OMR[2] is 0.
- 1    The pin is a request-to-send output (see Detailed Operation).



# Dual Universal Serial Communications Controller (DUSCC) SCN68562

2

**Table 2. Channel Configuration/Pin Definition Registers Bit Formats**

**CHANNEL MODE REG 1**

	BIT 7	BIT 6	BIT 5	BIT 4	BIT 3	BIT 2	BIT 1	BIT 0
<b>(CMR1A, CMR1B)</b>	<b>Data Encoding</b>		<b>Extended Control</b>	<b>Address Mode (BOP)</b>		<b>Channel Protocol Mode</b>		
	00 — NRZ/Manchester 01 — NRZI 10 — FMO 11 — FM1	BOP only 0 — no 1 — yes		00 — 8-bit 01 — extended address 10 — 16-bit 11 — 16-bit w/group	000 — BOP primary 001 — BOP secondary 010 — BOP loop 011 — BOP loop — no adr. comp.			
		<b>#Parity</b>	<b>Parity Mode (COP/ASYNC)</b>		100 — COP dual SYN 101 — COP dual SYN (BISYNC) 110 — COP single SYN 111 — asynchronous			
		0 — even 1 — odd	00 — no parity 01 — reserved 10 — with parity 11 — force parity					

**NOTE:**  
\*In BISYNC protocol mode, 0 = EBCDIC, 1 = ASCII coding.

**CHANNEL MODE REG 2**

	BIT 7	BIT 6	BIT 5	BIT 4	BIT 3	BIT 2	BIT 1	BIT 0
<b>(CMR2A, CMR2B)</b>	<b>Channel Connection</b>		<b>Data Transfer Interface</b>			<b>Frame Check Sequence Select</b>		
	00 — normal 01 — auto echo 10 — local loop 11 — reserved	000 — half-duplex single address DMA 001 — half-duplex dual address DMA 010 — full-duplex single address DMA 011 — full-duplex dual address DMA 100 — wait on Rx only 101 — wait on Tx only 110 — wait on Rx or Tx 111 — polled or interrupt	000 — none 001 — reserved 010 — LRC8 preset 0s 011 — LRC8 preset 1s 100 — CRC 16 preset 0s 101 — CRC 16 preset 1s 110 — CRC CCITT preset 0s 111 — CRC CCITT preset 1s					

**SYN1/SECONDARY ADDRESS REG 1**

	BIT 7	BIT 6	BIT 5	BIT 4	BIT 3	BIT 2	BIT 1	BIT 0
<b>(S1RA, S1RB)</b>	ASYNC — Character compare (5 – 8 bits) COP — SYN1 (5 – 8 bits) BOP — First address octet							

**SYN2/SECONDARY ADDRESS REG 2**

	BIT 7	BIT 6	BIT 5	BIT 4	BIT 3	BIT 2	BIT 1	BIT 0
<b>(S2RA, S2RB)</b>	ASYNC — not used COP — SYN2 (5 – 8 bits) BOP — Second address octet							

**PIN CONFIGURATION REG**

	BIT 7	BIT 6	BIT 5	BIT 4	BIT 3	BIT 2	BIT 1	BIT 0
<b>(PCRA, PCRB)</b>	<b>X2/IDC</b>	<b>GPO2/RTS</b>	<b>SYNOUT/RTS</b>	<b>RTxC Pin</b>		<b>TRxC Pin</b>		
	* 0 — X2 1 — IDC	0 — GPO2 1 — RTS	0 — SYNOUT 1 — RTS	00 — input 01 — C/T 10 — TxCLK 1× 11 — RxCLK 1×	000 — input 001 — XTAL/2 010 — DPLL 011 — C/T	100 — TxCLK 16× 101 — RxCLK 16× 110 — TxCLK 1× 111 — RxCLK 1×		

**NOTE:**  
\*PCRA only. Not used in PCRB.

# Dual Universal Serial Communications Controller (DUSCC) SCN68562

- [5] SYNOUT/RTS —**
- 0 The SYNOUT\_N/RTS\_N pin is an active low output which is asserted one bit time after a SYN pattern (COP modes) in HSRH/HSRL or FLAG (BOP modes) is detected in CCSR. The output remains asserted for one receiver clock period. See Figure 1 for receiver data path.
  - 1 The pin is a request-to-send output (see Detailed Operation). The logical state of the pin is controlled by OMR[0], when set the output is zero.
  - 01 The pin is an output from the counter/timer. Refer to CTCRA/B description.
  - 10 The pin is an output from the transmitter shift register clock.
  - 11 The pin is an output from the receiver shift register clock.
- [4:3] RTxC —**
- 00 The pin is an input. It must be programmed for input when used as the input for the receiver or transmitter clock, the DPLL, or the C/T.

**Table 3. Transmitter and Receiver Parameter and Timing Register Bit Format**

TRANSMITTER PARAMETER REG							
	BIT 7	BIT 6	BIT 5	BIT 4	BIT 3	BIT 2	BIT 1
(TPRA, TPRB)	Underrun Control		Idle	TEOM On Zero Cnt Or Done	Tx RTS Control	CTS Enable Tx	Tx Character Length
COP	00 — FCS-idle 01 — reserved 10 — MARKs 11 — SYNs		0 — MARKs 1 — SYNs	0 — no 1 — yes	0 — no 1 — yes	0 — no 1 — yes	00 — 5 bits 01 — 6 bits 10 — 7 bits 11 — 8 bits
BOP	Underrun Control		Idle	TEOM On Zero Cnt Or Done			
	00 — FCS-FLAG-idle 01 — reserved 10 — ABORT-MARKs 11 — ABORT-FLAGs		0 — MARKs 1 — FLAGs	0 — no 1 — yes			
ASYNc	Stop Bits Per Character						
	9/16 to 1, 17/16 to 1.5, 25/16 to 2 programmable in 1/16-bit increments						

TRANSMITTER TIMING REG							
	BIT 7	BIT 6	BIT 5	BIT 4	BIT 3	BIT 2	BIT 1
(TTRA, TTRB)	External Source	Transmitter Clock Select			Bit Rate Select		
	0 — RTxC 1 — TRxC	000 — 1× external 001 — 16× external 010 — DPLL 011 — BRG 100 — 2× other channel C/T 101 — 32× other channel C/T 110 — 2× own channel C/T 111 — 32× own channel C/T			one of sixteen rates from BRG		

RECEIVER PARAMETER REG							
	BIT 7	BIT 6	BIT 5	BIT 4	BIT 3	BIT 2	BIT 1
(RPRA, RPRB)	not used	not used	not used	Rx RTS Control	Strip* Parity	DCD Enable Rx	Rx Character Length
ASYNc				0 — no 1 — yes	0 — no 1 — yes	0 — no 1 — yes	00 — 5 bits 01 — 6 bits 10 — 7 bits 11 — 8 bits
COP	SYN Strip	FCS to FIFO	Auto Hunt & Pad Chk	Ext Sync	Strip* Parity		
	0 — no 1 — yes	0 — no 1 — yes	0 — no 1 — yes	0 — no 1 — yes	0 — no 1 — yes		
BOP	not used	FCS to FIFO	Overrun Mode	not used	All Parity Address		
		0 — no 1 — yes	0 — hunt 1 — cont		0 — no 1 — yes		

**NOTE:**  
\*If the receiver character length is 8-bits and parity is programmed, this bit must be set.

# Dual Universal Serial Communications Controller (DUSCC) SCN68562

**Table 3. Transmitter and Receiver Parameter and Timing Register Bit Format** (Continued)

RECEIVER TIMING REG		BIT 7	BIT 6	BIT 5	BIT 4	BIT 3	BIT 2	BIT 1	BIT 0
(RTRA, RTRB)	External Source	Receiver Clock Select				Bit Rate Select			
	0 — RTxC 1 — TRxC	000 — 1× external 001 — 16× external 010 — BRG 011 — C/T of channel 100 — DPLL, source = 64× X1/CLK 101 — DPLL, source = 32× External 110 — DPLL, source = 32× BRG 111 — DPLL, source = 32× C/T	} ASYNC protocol mode only		one of sixteen rates from BRG				

OUTPUT AND MISC REG		BIT 7	BIT 6	BIT 5	BIT 4	BIT 3	BIT 2	BIT 1	BIT 0
(OMRA, OMRB)	Tx Residual Character Length	TxRDY Activate		RxRDY Activate		OUT 2	OUT 1	RTS	
	000 — 1 bit 001 — 2 bits 010 — 3 bits 011 — 4 bits 100 — 5 bits 101 — 6 bits 110 — 7 bits 111 — same as TPR[1:0]	0 — FIFO not full 1 — FIFO empty	0 — FIFO not empty 1 — FIFO full	0 — 0 1 — 1	0 — 0 1 — 1	0 — 0 1 — 1			

**[2:0] TRxC —**

- 000 The pin is an input. It must be programmed for input when used as the input for the receiver or transmitter clock, the DPLL, or the C/T.
- 001 The pin is an output from the crystal oscillator. (XTAL/2)
- 010 The pin is an output from the DPLL output clock.
- 011 The pin is an output from the counter/timer. Refer to CTCRA/B description.
- 100 The pin is an output from the transmitter BRG at 16X the rate selected by TTR [3:0].
- 101 The pin is an output from the receiver BRG at 16X the rate selected by RTR [3:0].
- 110 The pin is an output from the transmitter shift register clock.
- 111 The pin is an output from the receiver shift register clock.

**Transmitter and Receiver Parameter and Timing Registers**

This set of five registers contains the information which controls the operation of the transmitter and receiver for each channel. Table 3 shows the bit map format for each of these registers. The registers of this group are:

1. Transmitter parameter and timing registers (TPRA/B and TTRA/B)
2. Receiver parameter and timing registers (RPRA/B and RTRA/B)

**3. Output and miscellaneous register (OMRA/B)**

The first and second group of registers define the transmitter and receiver parameters and timing. Included in the receiver timing registers are the programming parameters for the DPLL. The last register of the group, OMR contains additional transmitter and receiver information and controls the logical state of the output pins when they are not used as a part of the channel configuration.

**Transmitter Parameter Register (TPRA, TPRB)**

**[7:6] Underrun Control —** In BOP and COP modes, this field selects the transmitter response in the event of an underrun (i.e., the TxFIFO is empty).

00 Normal end of message termination. In BOP, the transmitter sends the FCS (if selected by CMR2[2:0]) followed by a FLAG and then either MARKs or FLAGs, as specified by [5]. In COP, the transmitter sends the FCS (if selected by CMR2[2:0]) and then either MARKs or SYNs, as specified by [5].

01 Reserved.

10 In BOP, the transmitter sends an ABORT (11111111) and then places the TxD output in a marking condition until receipt of further instructions. In COP, the transmitter places the TxD output in a marking condition until receipt of further instructions.

11 In BOP, the transmitter sends an ABORT (11111111) and then sends FLAGs until receipt of further instructions. In COP, the transmitter sends SYNs until receipt of further instructions.

**[5] Idle —** In BOP and COP modes, this bit selects the transmitter output during idle. Idle is defined as the state following a normal end of message until receipt of the next transmitter command.

0 Idle in marking condition.

1 Idle sending SYNs (COP) or FLAGs (BOP).

**[4] Transmit EOM on Zero Count or Done —** In BOP and COP modes, the assertion of this bit causes the end of message (FCS in COP, FCS-FLAG in BOP) to be transmitted upon the following events:

1. If the counter/timer is counting transmitted characters, after transmission of the character which causes the counter to reach zero count. (DONEN is also asserted as an output if the channel is in a DMA operation.)
2. If the channel is operating in DMA mode, after transmission of a character if DONEN was asserted when that character was loaded into the TxFIFO by the DMA controller.

**[7:4] Stop Bits per Character —** In ASYNC mode, this field programs the length of the stop bit appended to the transmitted character as shown in Table 4.

## Dual Universal Serial Communications Controller (DUSCC) SCN68562

**Table 4. Stop Bits — Transmitted Character**

[7:4]	5 BITS/ CHAR	6, 7, or 8 BITS/CHAR
0000	1.063	0.563
0001	1.125	0.625
0010	1.188	0.688
0011	1.250	0.750
0100	1.313	0.813
0101	1.375	0.875
0110	1.438	0.938
0111	1.500	1.000
1000	1.563	1.563
1001	1.625	1.625
1010	1.688	1.688
1011	1.750	1.750
1100	1.813	1.813
1101	1.875	1.875
1110	1.938	1.938
1111	2.000	2.000

Stop bit lengths of  $\frac{7}{16}$  to 1 and  $\frac{19}{16}$  to 2 bits, in increments of  $\frac{1}{16}$ -bit, can be programmed for character lengths of 6, 7, and 8 bits. For a character length of 5 bits,  $\frac{1}{16}$  to 2 stop bits can be programmed in increments of  $\frac{1}{16}$ -bit. The receiver only checks for a 'mark' condition at the center of the first stop bit position (one bit time after the last data bit, or after the parity bit if parity is enabled) in all cases.

If an external  $1\times$  clock (or a  $2\times$  clock for counter/timer) is used for the transmitter, [7] = 0 selects one stop bit and [7] = 1 selects two stop bits to be transmitted. If Manchester, NRZI, or FM data encoding is selected, only integral stop bit lengths should be used.

**[3] Transmitter Request-to-Send Control** — This bit controls the deactivation of the RTS\_N output by the transmitter (see Detailed Operation).

- 0 RTS\_N is not affected by status of transmitter.
- 1 RTS\_N changes state as a function of transmitter status.

**[2] Clear-to-Send Enable Transmitter** — The state of this bit determines if the CTS\_N input controls the operation of the channel's transmitter (see Detailed Operation). The duration of CTS level change is described in the discussion of ICTSR[4].

- 0 CTS\_N has no effect on the transmitter.
- 1 CTS\_N affects the state of the transmitter.

**[1:0] Transmitted Bits per Character** — This field selects the number of data bits per character to be transmitted. The character length does not include the start, parity, and stop bits in ASYNC or the parity bit in COP. In BOP modes the character length for the

address and control fields is always 8 bits, and the value of this field only applies to the information (I) field, except for the last character of the I field, whose length is specified by OMR[7:5].

**Transmitter Timing Register (TTRA, TTRB)**

**[7] External Source** — This bit selects the RTxC pin or the TRxC pin of the channel as the transmitter clock input when [6:4] specifies external. When used for input, the selected pin must be programmed as an input in the PCR [4:3] or [2:0].

- 0 External input from RTxC pin.
- 1 External input from TRxC pin.

**[6:4] Transmitter Clock Select** — This field selects the clock for the transmitter.

- 000 External clock from TRxC or RTxC at  $1\times$  the shift (baud) rate.
- 001 External clock from TRxC or RTxC at  $16\times$  the shift rate.
- 010 Internal clock from the phase locked loop at  $1\times$  the bit rate. It should be used only in half-duplex operation since the DPLL will periodically re-sync itself to the received data if in full-duplex operation.
- 011 Internal clock from the bit rate generator at  $32\times$  the shift rate. The clock signal is divided by two before use in the transmitter which operates at  $16\times$  the baud rate. Rate selected by [3:0].
- 100 Internal clock from counter/timer of other channel. The C/T should be programmed to produce a clock at  $2\times$  the shift rate.
- 101 Internal clock from counter/timer of other channel. The C/T should be programmed to produce a clock at  $32\times$  the shift rate.
- 110 Internal clock from the counter/timer of own channel. The C/T should be programmed to produce a clock at  $2\times$  the shift rate.
- 111 Internal clock from the counter/timer of own channel. The C/T should be programmed to produce a clock at  $32\times$  the shift rate.

**[3:0] Bit Rate Select** — This field selects an output from the bit rate generator to be used by the transmitter circuits. The actual frequency output from the BRG is  $32\times$  the bit rate shown in Table 5. With a crystal or external clock of 14.7456MHz the bit rates are as given in Table 5 (this input is divided by two before being applied to the oscillator circuit).

**Table 5. Receiver/Transmitter Baud Rates**

[3:0]	BIT RATE	[3:0]	BIT RATE
0000	50	1000	1050
0001	75	1001	1200
0010	110	1010	2000
0011	134.5	1011	2400
0100	150	1100	4800
0101	200	1101	9600
0110	300	1110	19.2k
0111	600	1111	38.4k

**Receiver Parameter Register (RPRA, RPRB)**

**[7] SYN Stripping** — This bit controls the DUSCC processing in COP modes of SYN 'character patterns' that occur after the initial character synchronization. Refer to Detailed Operation of the receiver for details and definition of SYN 'patterns', and their accumulation of FCS.

- 0 Strip only leading SYN 'patterns' (i.e. before a message).
- 1 Strip all SYN 'patterns' (including all odd DLE's in BISYNC transparent mode).

**[6] Transfer Received FCS to FIFO** — In BISYNC and BOP modes, the assertion of this bit causes the received FCS to be loaded into the RxFIFO. BOP mode operates correctly only if a minimum of two extra FLAGS (without shared zeros) are appended to the frame. If the FCS is specified to be transferred to the FIFO, the EOM status bit will be tagged onto the last byte of the FCS instead of to the last character of the message.

- 0 Do not transfer FCS to RxFIFO.
- 1 Transfer FCS to RxFIFO.

**[5] Auto-Hunt and Pad Check (BISYNC)** — In BISYNC mode, the assertion of this bit causes the receiver to go into hunt for character sync mode after detecting certain end-of-message (EOM) characters. These are defined in the Detailed Operations section for COP receiver operation. After the EOT and NAK sequences, the receiver also does a check for a closing PAD of four 1s.

- 0 Disable auto-hunt and PAD check.
- 1 Enable auto-hunt and PAD check.

**[5] Overrun Mode (BOP)** — The state of this control bit determines the operation of the receiver in the event of a data overrun, i.e., when a character is received while the RxFIFO and the Rx shift register are both full.

- 0 The receiver terminates receiving the current frame and goes into hunt phase, looking for a FLAG to be received.

# Dual Universal Serial Communications Controller (DUSCC)      SCN68562

2

1 The receiver continues receiving the current frame. The overrunning character is lost. (The five characters already assembled in the Rx FIFO and Rx shift register are protected).

#### [4] Receiver Request-to-Send Control (ASYNC) — See Detailed Operation.

0 Receiver does not control RTS\_N output.

1 Receiver can negate RTS\_N output.

**[4] External Sync (COP)** — In COP single SYN mode, the assertion of this bit enables external character synchronization and receipt of SYN patterns is not required. In order to use this feature, the DUSCC must be programmed to COP single SYN mode, CMR1[2:0] = 110, which is used to set up the internal data paths. In all other respects, however, the external sync mode operation is protocol transparent. A negative signal on the DCD\_N/SYLN\_N pin will cause the receiver to establish synchronization on the next rising edge of the receiver clock. Character assembly will start at this edge with the Rx D input pin considered to have the second bit of data. The sync signal can then be negated. Receipt of the active high external sync input causes the SYN detect status bit (RSR[2]) to be set and the SYNOUT\_N pin to be asserted for one bit time. When this mode is enabled, the internal SYN (COP mode) detection and special character recognition (e.g., IDLE, STx, ETx, etc.) circuits are disabled. Character assembly begins as if in the I-field with character length as programmed in RPR[1:0]. Incoming COP frames with parity specified optionally can have it stripped by programming RPR[3]. The user must wait at least eight bit times after Rx is enabled before applying the SYN\_N signal. This time is required to flush the internal data paths. The receiver remains in this mode and further external sync pulses are ignored until the receiver is disabled and then reenabled to resynchronize or to return to normal mode. See Figure 2.

0 External sync not enabled.

1 External sync enabled.

Note that EXT SYNC and DCD ENABLE Rx cannot be asserted simultaneously since they use the same pin.

**[3] Strip Parity** — In COP and ASYNC modes with parity enabled, this bit controls whether the received parity bit is stripped from the data placed in the receiver FIFO. It is valid only for programmed character lengths of 5, 6, and 7 bits. If the bit is stripped, the corresponding bit in the received data is set to zero. This bit must be set to A '1' if 8-bit character length will parity is programmed.

0 Transfer parity bit as received.

1 Strip parity bit from data.

**[3] All Parties Address** — In BOP secondary modes, the assertion of this bit causes the receiver to 'wake up' upon receipt of the address H'FF' or H'FF, FF', for single- and dual-octet address modes, respectively, in addition to its normal station address. This feature allows all stations to receive a message.

0 Don't recognize all parties address.

1 Recognize all parties address.

**[2] DCD Enable Receiver** — If this bit is asserted, the DCD\_N/SYLN\_N input must be low in order for the receiver to operate. If the input is negated (goes high) while a character is being received, the receiver terminates receipt of the current message (this action in effect disables the receiver). If DCD is subsequently asserted, the receiver will search for the start bit, SYN pattern, or FLAG, depending on the channel protocol. (Note that the change of input can be programmed to generate an interrupt; the duration of the DCD level change is described in the discussion of the input and counter/timer status register ICTSR[5]).

0 DCD not used to enable receiver

1 DCD used to enable receiver

EXT SYNC and DCD ENABLE Rx cannot be asserted simultaneously since they use the same pin.

**[1:0] Received Bits per Character** — This field selects the number of data bits per character to be assembled by the receiver. The character length does not include the start, parity, and stop bits in ASYNC or the parity bit in COP. In BOP modes, the character length for the address and control fields is always 8 bits, and the value of this field only applies to the information field. If the number of bits assembled for the last character of the I field is less than the value programmed in this field, RCL not zero (RSR[0]) is asserted and the actual number of bits received is given in TRSR[2:0].

#### Receiver Timing Register (RTRA, RTRB)

**[7] External Source** — This bit selects the RTxC pin or the TRxC pin of the channel as the receiver or DPLL clock input, when [6:4] specifies external. When used for input, the selected pin must be programmed as an input in the PCR [4:3] or [2:0].

0 External input from RTxC pin.

1 External input from TRxC pin.

**[6:4] Receiver Clock Select** — This field selects the clock for the receiver.

000 External clock from TRxC or RTxC at 1 × the shift (baud) rate.

001 External clock from TRxC or RTxC at 16 × the shift rate. Used for ASYNC mode only.

010 Internal clock from the bit rate generator at 32 × the shift rate. Clock is divided by two before use by the receiver logic, which operates at 16 × the baud rate. Rate selected by [3:0]. Used for ASYNC mode only.

011 internal clock from counter/timer of own channel. The C/T should be programmed to produce a clock at 32 × the shift rate. Clock is divided by two before use in the receiver logic. Used for ASYNC mode only.

100 Internal clock from the digital phase locked loop. The clock for the DPLL is a 64 × clock from the crystal oscillator or system clock input. (The input to the oscillator is divided by two).

101 Internal clock from the digital phase locked loop. The clock for the DPLL is an external 32 × clock from the RTxC or TRxC pin, as selected by [7].

110 Internal clock from the digital phase locked loop. The clock for the DPLL is a 32 × clock from the BRG. The frequency is programmed by [3:0].

111 Internal clock from the digital phase locked loop. The clock for the DPLL is a 32 × clock from the counter/timer of the channel.

**[3:0] Bit Rate Select** — This field selects an output from the bit rate generator to be used by the receiver circuits. The actual frequency output from the BRG is 32 × the bit rate shown in Table 5.

#### Output and Miscellaneous Register (OMRA, OMRB)

**[7:5] Transmitted Residual Character Length** — In BOP modes, this field determines the number of bits transmitted for the last character in the information field. This length applies to:

- the character in the transmit FIFO accompanied by the FIFOed TEOM command.

- the character loaded into the FIFO by the DMA controller if DONEN is simultaneously asserted and TPR[4] is asserted.

- the character loaded into the FIFO which causes the counter to reach zero count when TPR[4] is asserted.

The length of all other characters in the frame's information field is selected by TPR[1:0]. If this field is 111, the number of bits in the last character is the same as programmed in TPR[1:0].

# Dual Universal Serial Communications Controller (DUSCC)      SCN68562

## [4] TxRDY Activate Mode —

0 FIFO not full. The channel's TxRDY status bit is asserted each time a character is transferred from the transmit FIFO to the transmit shift register. If not reset by the CPU, TxRDY remains asserted until the FIFO is full, at which time it is automatically negated.

1 FIFO empty. The channel's TxRDY status bit is asserted when a character transfer from the transmit FIFO to the transmit shift register causes the FIFO to become empty. If not reset by the CPU, TxRDY remains asserted until the FIFO is full, at which time it is negated.

If the TxRDY status bit is reset by the CPU, it will remain negated regardless of the current state of the transmit FIFO, until it is asserted again due to the occurrence of one of the above conditions.

## [3] RxRDY Activate Mode —

0 FIFO not empty. The channel's RxRDY status bit is asserted each time a character is transferred from the receive shift register to the receive FIFO. If not reset by the CPU, RxRDY remains asserted until the receive FIFO is empty, at which time it is automatically negated.

1 FIFO full. The channel's RxRDY status bit is asserted when a character transfer from the receive shift register to the receive FIFO causes the FIFO to become full. If not reset by the CPU, RxRDY remains asserted until the FIFO is empty, at which time it is negated.

The RxRDY status bit will also be asserted, regardless of the receiver FIFO full condition, when an end-of-message character is loaded in the Rx FIFO (BOP/BISYNC), when a BREAK condition (ASYNC mode) is detected in RSR[2], or when the counter/timer is programmed to count received characters and the character which causes it to reach zero is loaded in the FIFO (all modes). (Refer to the detailed operation of the receiver.)

If reset by the CPU, the RxRDY status bit will remain negated, regardless of the current state of the receiver FIFO, until it is asserted again due to one of the above conditions.

[2] **General Purpose Output 2** — This general purpose bit is used to control the TxDRQ\_N/GP02\_/RTS\_N pin, when it is

used as an output. The output is high when the bit is a 0 and is low when the bit is a 1.

[1] **General Purpose Output 1** — This bit is used to control the RTxDRQ\_N/GPO1\_N output, which is a general purpose output when the channel is not in DMA mode. The output is high when the bit is a 0 and is low when the bit is a 1.

[0] **Request-to-Send Output** — This bit controls the TxDRQ\_N/GPO2\_N/RTS\_N and SYNOUT\_N/RTS\_N pin, when either is used as a RTS output. The output is high when the bit is a 0 and is low when the bit is a 1.

## Counter/Timer Control and Value Registers

There are five registers in this set consisting of the following:

1. Counter/timer control register (CTCRA/B)
2. Counter/timer preset high and low registers (CTPRHA/B, CTPLA/B)
3. Counter/timer (current value) high and low registers (CTHA/B, CTLA/B)

The format of each of the registers of this set is contained in Table 6. The control register contains the operational information for the counter/timer. The preset registers contain the count which is loaded into the counter/timer circuits. The third group contains the current value of the counter/timer as it operates.

## Counter/Timer Control Register (CTCRA, CTCRB)

[7] **Zero Detect Interrupt** — This bit determines whether the assertion of the C/T ZERO COUNT status bit (ICTSR[6]) causes an interrupt to be generated.

- 0 Interrupt disabled.
- 1 Interrupt enabled if master interrupt enable (ICR[1] or ICR[0]) is asserted.

[6] **Zero Detect Control** — This bit determines the action of the counter upon reaching zero count.

- 0 The counter/timer is preset to the value contained in the counter/timer preset registers (CTPRL, CTPRH) at the next clock edge.

- 1 The counter/timer continues counting without preset. The value at the next clock edge will be H'FFFF'.

[5] **Counter/Timer Output Control** — This bit selects the output waveform when the counter/timer is selected to be output on TRxC or RTxC.

- 1 The output is a single clock positive width pulse each time the C/T reaches zero count. (The duration of this pulse is one clock period.)

- 0 The output toggles each time the C/T reaches zero count. The output is cleared to low by either of the preset counter/timer commands.

[4:3] **Clock Select** — This field selects whether the clock selected by [2:0] is prescaled prior to being applied to the input of the C/T.

- 00 No prescaling.
- 01 Divide clock by 16.
- 10 Divide clock by 32.
- 11 Divide clock by 64.

[2:0] **Clock Source** — This field selects the clock source for the counter timer.

- 000 RTxC pin. Pin must be programmed as input.
- 001 TRxC pin. Pin must be programmed as input.
- 010 Source is the crystal oscillator or system clock input divided by four.
- 011 This selects a special mode of operation. In this mode the counter, after receiving the 'start C/T' command, delays the start of counting until the Rx D input goes low. It continues counting until the Rx D input goes high, then stops and sets the C/T zero count status bit. The CPU can use the value in the C/T to determine the bit rate of the incoming data. The clock is the crystal oscillator or system clock input divided by four.

- 100 Source is the 32× BRG output selected by RTR[3:0] of own channel.

- 101 Source is the 32× BRG output selected by TTR[3:0] of own channel.

- 110 Source is the internal signal which loads received characters from the receive shift register into the receiver FIFO. When operating in this mode, the FIFoed EOM status bit (RSR[7]) shall be set when the character which causes the count to go to zero is loaded into the receive FIFO.

- 111 Source is the internal signal which transfers characters from the data bus into the transmit FIFO. When operating in this mode, and if the TEOM on zero count or done control bit (TPR[4]) is asserted, the FIFoed Send EOM command will be automatically asserted when the character which causes the count to go to zero is loaded into the transmit FIFO.

## Counter/Timer Preset High Register (CTPRHA, CTPRH)

[7:0] **MSB** — This register contains the eight most significant bits of the value loaded into

# Dual Universal Serial Communications Controller (DUSCC) SCN68562

2

**Table 6. Counter/Timer Control and Value Register Bit Formats**

COUNTER/TIMER CONTROL REG								
	BIT 7	BIT 6	BIT 5	BIT 4	BIT 3	BIT 2	BIT 1	BIT 0
(CTCRA, CTCRB)	<b>Zero Detect Interrupt</b>	<b>Zero Detect Control</b>	<b>Output Control</b>	<b>Prescaler</b>		<b>Clock Source</b>		
	0 — disable 1 — enabled	0 — preset 1 — continue	0 — square 1 — pulse	00 — 1 01 — 16 10 — 32 11 — 64		000 — RTxC pin 001 — TRxC pin 010 — X1/CLK divided by 4 011 — X1/CLK divided by 4 gated by RxD 100 — Rx BRG 101 — Tx BRG 110 — Rx characters 111 — Tx characters		
COUNTER/TIMER PRESET HIGH REG								
	BIT 7	BIT 6	BIT 5	BIT 4	BIT 3	BIT 2	BIT 1	BIT 0
(CTPRHA, CTPRHB)	Most significant bits of counter/timer preset value							
COUNTER/TIMER PRESET REGISTER LOW								
	BIT 7	BIT 6	BIT 5	BIT 4	BIT 3	BIT 2	BIT 1	BIT 0
(CTPRLA, CTPRLB)	Least significant bits of counter/timer preset value							
COUNTER/TIMER HIGH								
	BIT 7	BIT 6	BIT 5	BIT 4	BIT 3	BIT 2	BIT 1	BIT 0
(CTHA, CTHB)	Most significant bits of counter/timer							
COUNTER/TIMER LOW								
	BIT 7	BIT 6	BIT 5	BIT 4	BIT 3	BIT 2	BIT 1	BIT 0
(CTLA, CTLB)	Least significant bits of counter/timer							

the counter/timer upon receipt of the load C/T from preset register command or when the counter/timer reaches zero count and the zero detect control bit (CTCR[6]) is negated. The minimum 16-bit counter/timer preset value is H'0002'.

**Counter/Timer Preset Low Register (CTPRLA, CTPRLB)**

[7:0] **LSB** — This register contains the eight least significant bits of the value loaded into the counter/timer upon receipt of the load C/T from preset register command or when the counter/timer reaches zero count and the zero detect control bit (CTCR[6]) is negated. The minimum 16-bit counter/timer preset value is H'0002'.

**Counter/Timer High Register (CTHA, CTHB)**

[7:0] **MSB** — A read of this 'register' provides the eight most significant bits of the current value of the counter/timer. It is recommended that the C/T be stopped via a stop counter command before it is read in order to prevent errors which may occur due to the read being performed while the C/T is changing. This count is continued after the register is read.

**Counter/Timer Low Register (CTLA, CTLB)**

[7:0] **LSB** — A read of this 'register' provides the eight least significant bits of the current value of the counter/timer. It is recommended that the C/T be stopped via a stop

counter command before it is read, in order to prevent errors which may occur due to the read being performed while the C/T is changing. This count is continued after the register is read.

**Interrupt Control and Status Registers**

This group of registers define mechanisms for communications between the DUSCC and the processor and contain the device status information. Four registers, available for each channel, and four common device registers comprise this group which consists of the following:

1. Interrupt enable register (IERA/B)
2. Receiver status register (RSRA/B)
3. Transmitter and receiver status register (TRSRA/B)

# Dual Universal Serial Communications Controller (DUSCC) SCN68562

- 4. Input and counter/timer status register (ICTSRA/B)
- 5. Interrupt vector register (IVR) and modified interrupt vector register (IVRM)
- 6. Interrupt control register (ICR)
- 7. General status register (GSR)

See Table 7 for bit formats and Figure 3 for table relationships.

**Interrupt Enable Register (IERA, IERB)**

This register controls whether the assertion of bits in the channel's status registers causes an interrupt to be generated. An additional condition for an interrupt to be generated is that the channel's master interrupt enable bit, ICR[0] or ICR[1], be asserted.

**[7] DCD/CTS —**

- 0 Interrupt not enabled.
- 1 Interrupt generated if ICTSR[4] or ICTSR[5] are asserted.

**[6] TxRDY —**

- 0 Interrupt not enabled.
- 1 Interrupt generated if TxRDY (GSR[1] or GSR[5] for channels A and B respectively) is asserted.

**[5] TRSR 73 —**

- 0 Interrupt not enabled.
- 1 Interrupt generated if bits 7, 6, 5, 4 or 3 of the TRSR are asserted.

**[4] RxRDY —**

- 0 Interrupt not enabled.
- 1 Interrupt generated if RxRDY (GSR[0] or GSR[4] for channels A and B respectively) is asserted.

**[3] RSR 76 —**

- 0 Interrupt not enabled.
- 1 Interrupt generated if bits 7 or 6 of the RSR are asserted.

**[2] RSR 54 —**

- 0 Interrupt not enabled.
- 1 Interrupt generated if bits 5 or 4 of the RSR are asserted.

**[1] RSR 32 —**

- 0 Interrupt not enabled.
- 1 Interrupt generated if bits 3 or 2 of the RSR are asserted.

**Table 7. Interrupt Control and Status Register Bit Format**

		*BIT 7	BIT 6	BIT 5	BIT 4	BIT 3	BIT 2	BIT 1	BIT 0
(RSRA, RSRB) ASYNC  COP  BOP  LOOP	# Char compare	RTS negated	Overrun error	not used	BRK end detect	BRK start detect	# Framing error	# Parity error	
	# EOM detect +	PAD error +	Overrun error	not used	not used	Syn detect	# CRC error	# Parity error	
	# EOM detect	Abort detect	Overrun error	Short frame detect	Idle detect	Flag detect	# CRC error	# RCL not zero	
	# EOM detect	Abort/EOP detect	Overrun error	Short frame detect	Turn-around detect	Flag detect	# CRC error	# RCL not zero	

**NOTES:**

- \* Status bit is FIFOed.
- + COP BISYNC mode only.
- \* All modes indicate character count complete.

**TRANSMITTER AND RECEIVER STATUS REG**

		BIT 7	BIT 6	BIT 5	BIT 4	BIT 3	BIT 2	BIT 1	BIT 0
(TRSRA, TRSRB) ASYNC  COP  BOP	Transmitter empty	CTS underrun	not used	Send break ack	DPLL error	not used	not used	not used	
	Transmitter empty	CTS underrun	Frame complete	Send SOM ack	DPLL error	not used	Rx hunt mode	Rx xpnt mode	
	Transmitter empty	CTS underrun Loop sending*	Frame complete	Send SOM/ abort ack	DPLL error	<b>Rx Residual Character Length</b>			
						000 — 0 bit		100 — 4 bits	
						001 — 1 bits		101 — 5 bits	
						010 — 2 bits		110 — 6 bits	
						011 — 3 bits		111 — 7 bits	

**NOTE:**

- \*Loop mode only

**INPUT AND COUNTER/TIMER STATUS REGISTER**

		BIT 7	BIT 6	BIT 5	BIT 4	BIT 3	BIT 2	BIT 1	BIT 0
(ICTSRA, ICTSRB)	C/T running	C/T zero count	Delta DCD	Delta CTS/LC	DCD	CTS/LC	GPI2	GPI1	



# Dual Universal Serial Communications Controller (DUSCC) SCN68562

**Table 7. Interrupt Control and Status Register Bit Format (Continued)**

INTERRUPT ENABLE REG								
	BIT 7	BIT 6	BIT 5	BIT 4	BIT 3	BIT 2	BIT 1	BIT 0
(IERA, IERB)	DCD/CTS	TxRDY	TRSR [7:3]	RxRDY	RSR [7:6]	RSR [5:4]	RSR [3:2]	RSR [1:0]
	0 — no 1 — yes	0 — no 1 — yes	0 — no 1 — yes	0 — no 1 — yes	0 — no 1 — yes	0 — no 1 — yes	0 — no 1 — yes	0 — no 1 — yes
INTERRUPT VECTOR REG AND INTERRUPT VECTOR MODIFIED REG								
	BIT 7	BIT 6	BIT 5	BIT 4	BIT 3	BIT 2	BIT 1	BIT 0
(IVR, IVRM)	8-bit interrupt vector							
GENERAL STATUS REG								
	BIT 7	BIT 6	BIT 5	BIT 4	BIT 3	BIT 2	BIT 1	BIT 0
(GSR)	Channel B				Channel A			
	External or C/T status	Rx/Tx status	TxRDY	RxRDY	External or C/T status	Rx/Tx status	TxRDY	RxRDY
INTERRUPT CONTROL REG								
	BIT 7	BIT 6	BIT 5	BIT 4	BIT 3	BIT 2	BIT 1	BIT 0
(ICR)	Channel A/B Interrupt Priority		Vector Mode		Bits to Modify	Vector Includes Status	Channel A Master Int Enable	Channel B Master Int Enable
	00 — channel A 01 — channel B 10 — interleaved A 11 — interleaved B		00 — vectored 01 — vectored 10 — vectored 11 — non vectored		0 — 2:0 1 — 4:2	0 — no 1 — yes	0 — no 1 — yes	0 — no 1 — yes

**[0] RSR 10 —**

- 0 Interrupt not enabled.
- 1 Interrupt generated if bits 1 or 0 of the RSR are asserted.

**Receiver Status Register (RSRA, RSRB)**

This register informs the CPU of receiver status. Bits indicated as 'not used' in a particular mode will read as zero. The logical OR of these bits is presented in GSR[2] or GSR[6] (ORed with the bits of TRSR) for channels A and B, respectively. Unless otherwise indicated, asserted status bits are reset only by performing a write operation to the status register with the bits to be reset being ones in the accompanying data word, or when the RESETN input is asserted, or when a 'reset receiver' command is issued.

Certain status bits are specified as being FIFOed. This means that they occupy positions in a status FIFO that correspond to the data FIFO. As the data is brought to the top of the FIFO (the position read when the RxFIFO is read), the FIFOed status bits are logically ORed with the previous contents of the corresponding bits in the status register. This permits the user to obtain status either char-

acter by character or on a block basis. For character by character status, the SR bits should be read and then cleared before reading the character data from RxFIFO. For block status, the status register is initially cleared and then read after the message is received. Asserted status bits can be programmed to generate an interrupt (see Interrupt Enable Register).

**[7] Character Count Complete (All Modes), Character Compare (ASYNC), EOM (BI-SYNC/BOP/LOOP) —** If the counter/timer is programmed to count received characters, this bit is asserted when the character which causes the count to go to zero is loaded into the receive FIFO. It is also asserted to indicate the following conditions:

- ASYNC** The character currently at the top of RxFIFO matched the contents of S1R. A character will not compare if it is received with parity error even if the data portion matches.
- BI SYNC** The character currently at the top of the FIFO was either a text message terminator or a control

sequence received outside of a text or header field. See Detailed Operation of COP Receiver. If transfer FCS to FIFO (RPR[6]) is set, the EOM will instead be tagged onto the last byte of the FCS. Note that if an overrun occurs during receipt of a message, the EOM character may be lost, but this status bit will still be asserted to indicate that an EOM was received. For two-byte EOM comparisons, only the second byte is tagged (assuming the CRC is not transferred to the FIFO).

BOP,  
LOOP

The character currently at the top of the FIFO was the last character of the frame. If transfer FCS to FIFO (RPR[6]) is asserted, the EOM will be tagged instead onto the last byte of the FCS. Note that if an overrun occurs, the EOM character may be lost, but this status bit will still be asserted to indicate that an EOM was received. This bit will not be set when an abort is received.

## Dual Universal Serial Communications Controller (DUSCC)

SCN68562

**[6] RTS Negated (ASYNC), PAD Error (BISYNC), ABORT (BOP) —**

**ASYNC** The RTSN output was negated due to receiving the start bit of a new character while the Rx FIFO was full (see RPR[4]).

**BISYNC** PAD error detected (see RPR[5]).

**BOP** An ABORT sequence consisting of a zero followed by seven ones was received after receipt of the first address octet but before receipt of the closing FLAG. The user should read Rx FIFO until it is empty and determine if any valid characters from a previous frame are in the FIFO. If no character with a tagged EOM detect ([7]) is found, all characters are from the current frame and should be discarded along with any previously read by the CPU. An ABORT detect causes the receiver to automatically go into search for FLAG state. An abort during a valid frame does not cause the CRC to reset; this will occur when the next frame begins.

**LOOP** Performs the ABORT detect function as described for BOP without the restriction that the pattern be detected during an active frame. A zero followed by seven ones is the end-of-poll sequence which allows the transmitter to go active if the 'go active on poll' command has been invoked.

**[5] Overrun Error (All Modes) —** A new character was received while the receive FIFO was full and a character was already waiting in the receive shift register to be transferred to the FIFO. The DUSCC protects the five characters previously assembled (four in Rx FIFO, one in the Rx shift register) and discards the overrunning character(s). After the CPU reads the FIFO, the character waiting in the RxSR will be loaded into the available FIFO position. This releases the RxSR and a new character assembly will start at the next character boundary. In this way, only valid characters will be assembled, i.e. no partial character assembly will occur regardless of when the RxSR became available during the incoming data stream.

**[4] Short Frame (BOP/LOOP) —**

**ASYNC** Not used

**COP** Not used

**BOP, LOOP** A closing flag was received with missing fields in the frame. See detailed operation for BOP receiver.

**[3] BREAK End Detect (ASYNC), IDLE (BOP), Turnaround (LOOP) —**

**ASYNC** 1× clock mode: The Rx D input has returned to the marking state for at least one period of the 1× receiver clock after detecting a BREAK.

16× clock mode: The Rx D input has returned to the marking (high) state for at least one-half bit time after detecting a BREAK. A half-bit time is defined as eight clock cycles of the 16× receiver clock.

**COP** Not used

**BOP** An IDLE sequence consisting of a zero followed by fifteen ones was received. During a valid frame, an abort must precede an idle. However, outside of a valid frame, an idle is recognized and abort is not.

**LOOP** A turnaround sequence consisting of eight contiguous zeros was detected outside of an active frame. This should normally be used to terminate transmitter operation and return the system to the 'echoing Rx D' mode.

**[2] BREAK Start Detect (ASYNC), SYN Detect (COP), FLAG Detect (BOP/LOOP)**

**ASYNC** An all zero character, including parity (if specified) and first stop bit, was received. The receiver shall be capable of detecting breaks which begin in the middle of a previous character. Only a single all-zero character shall be put into the FIFO when a break is detected. Additional entries to the FIFO are inhibited until the end of break has been detected (see above) and a new character is received.

**COP** A SYN pattern was received. Refer to Detailed Operation for definition of SYN patterns. Set one bit time after detection of SYN pattern in HSRH, HSRL. See Figure 1 for receiver data path.

**BOP, LOOP** A FLAG sequence (01111110) was received. Set one bit time after FLAG is detected in CCSR. See Figure 1 for receiver data path.

**[1] Framing Error (ASYNC), CRC Error (COP/BOP/LOOP) —**

**ASYNC** At the first stop bit position the Rx D input was in the low (space) state. The receiver only checks for framing error at the nominal center of the first stop bit regardless of the number of stop bits programmed in TPR[7:4]. This bit is not set for BREAKS.

**COP**

In BISYNC COP mode, this bit is set upon receipt of the BCC byte(s), if any, to indicate that the received BCC was in error. The bit is normally FIFOed with the last byte of the frame (the character preceding the first BCC byte). However, if transfer FCS to FIFO (RPR[6]) is asserted, this bit is FIFOed with the last BCC byte. The value of this bit should be ignored for non-text messages or if the received frame was aborted via an ENQ. In non-BISYNC COP modes, the bit is set with each received character if the current value of the CRC checker is not equal to the non-error value (see CMR2[2:0]).

**BOP, LOOP**

This bit is set upon receipt of the FCS byte(s), if any, to indicate that the received FCS was in error. The bit is normally FIFOed with the last byte of the 1 field (the character preceding the first FCS byte). However, if transfer FCS to FIFO (RPR[6]) is asserted, this bit is FIFOed with the last FCS byte.

**[0] Parity Error (ASYNC/COP), RCL Not Zero (BOP/LOOP) —**

**ASYNC** The parity bit of the received character was not as expected. A parity error does not affect the parity bit put into the FIFO as part of the character when strip parity (RPR [3]) is negated.

**COP**

The parity bit of the received character was not as expected. A parity error does not affect the parity bit put into the FIFO as part of the character when strip parity (RPR[3]) is negated. A SYN or other character received with parity error is treated as a data character. Thus, a SYN with parity error received while in SYN search state will not establish character sync. Characters received with parity error while in the SYN search state will not set the error bit.

**BOP, LOOP**

The last character of the 1 field did not have the character length specified in RPR[1:0]. The actual received character length of this byte can be read in TRSR[2:0]. This bit is FIFOed with the EOM character but TRSR[2:0] is not. An exception occurs if the command to transfer the FCS to the FIFO is active. In this case, the bit will be FIFOed with the last byte of the FCS, i.e., with REOM. In the event

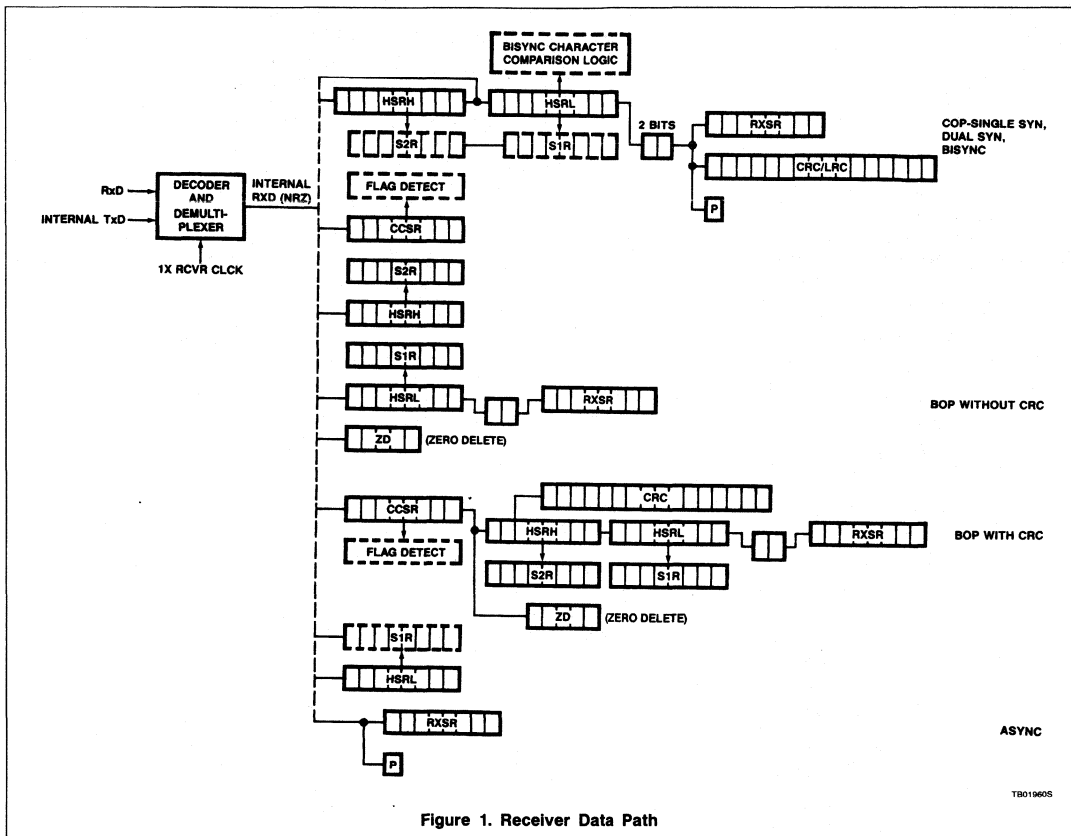

Figure 1. Receiver Data Path

that residual characters from two consecutive frames are received and are both in the FIFO, the length in TRSR[2:0] applies to the last received residual character.

**Transmitter/Receiver Status Register (TRSRA, TRSRB)**

This register informs the CPU of transmitter and receiver status. Bits indicated as not used in a particular mode will read as zero, except for bits [2:0], which may not be zero. The logical-OR of bits [7:3] is presented in GSR[2] or GSR[6] (ORed with the bits of RSR) for channels A and B, respectively. Unless otherwise indicated, asserted status bits are reset only:

1. By performing a write operation to the status register with the bits to be reset being ones in the accompanying data word [7:3].
2. When the RESETN input is asserted.

3. For [7:4], when a 'reset transmitter' command is issued.
4. For [3:0], when a 'reset receiver' command is issued.
5. For [2:0], see description in BOP mode.

Asserted status bits in [7:3] can be programmed to generate an interrupt. See IER.

**[7] Transmitter Empty** — Indicates that the transmit shift register has completed serializing a character and found no other character to serialize in the TxFIFO. The bit is not set until at least one character from the transmit FIFO (not including PAD characters in synchronous modes) has been serialized. The transmitter action after transmitter empty depends on operating mode:

ASYNC The Tx/D output is held in the MARK state until another character is loaded into the TxFIFO. Normal operation then continues.

COP Action is specified by TPR[7:6].  
 BOP, LOOP Action is specified by TPR[7:6].

**[6] CTS Underrun (ASYNC/COP/BOP), Loop sending (LOOP) —**

ASYNC, COP, BOP This bit is set only if CTS enable Tx (TPR[2]) is asserted. It indicates that the transmit shift register was ready to begin serializing a character and found the CTS\_N input negated. In ASYNC mode, this bit will be reassorted if cleared by the CPU while the CTS\_N input is negated.

LOOP Asserted when the go active on poll command has been invoked and an EOP sequence has been detected, causing the transmitter to go active by changing the EOP to a FLAG (see detailed operation of transmitter).

TB019605

## Dual Universal Serial Communications Controller (DUSCC)

SCN68562

**[5] Frame Complete (COP/BOP) —**

**ASYN** Not used.

**COP** Asserted at the beginning of transmission of the end of message sequence invoked by which is either a TEOM command, or when TPR[4], or TPR[7:6] = 00. The CPU can invoke the TSOM command after this bit is set to control the number of SYN's between transmitted frames.

**BOP** Asserted at the beginning of transmission of the end of message sequence which is invoked by either a TEOM command, or when TPR[4] = 1, or TPR[7:6] = 00. The CPU can invoke the TSOM command after this bit is set to control the number of FLAG's between transmitted frames.

In COP/BOP modes, the frame complete status bit is set during the next-to-last bit (on TxD pin) of the last character in the data/information field. In BOP mode, if a 1-bit residual character is selected through OMR[7:5], then this bit is set during the next-to-last bit (on TxD pin) of the last full length character of the information field.

**[4] Send Break Ack (ASYN)/Send SOM ACK (COP)/Send SOM-Abort Ack (BOP) —**

**ASYN** Set when the transmitter begins transmission of a break in response to the send break command. If the command is reinvoked, the bit will be set again at the beginning of the next character time. The user can control the length of the break by counting character times through this mechanism.

**COP** Set when the transmitter begins transmission of a SYN pattern in response to the TSOM or TSOMP command. If the command is reinvoked, the bit will be set again at the beginning of the next transmitted SYN pattern. The user can control the number of SYN's which are sent through this mechanism.

**BOP** Set when the transmitter begins transmission of a FLAG/ABORT in response to the TSOM or TSOMP or TABRK command. If the command is reinvoked, the bit will be set again at the beginning of the next transmitted FLAG/ABORT. The user can control the number of FLAG's/ABORT's which are sent through this mechanism.

**[3] DPLL Error** — Set while the DPLL is operating in FM mode to indicate that a data transition was not detected within the detec-

tion window for two consecutive bits and that the DPLL was forced into search mode. This feature is disabled when the DPLL is specified as the clock source for the transmitter via TTR[6:4].

**[2:0] Received Residual Character Length (BOP) —**

**BOP** This field should be examined to determine the length of the last character of the I field (character tagged with REOM status bit) if RSR[0] is set to indicate that the length was not equal to the character length specified in RPR[1:0]. This field is negated when a reset receiver or disable receiver command is issued, or when the first control character for the next frame of data is in HSRL (see Figure 1). Care must be taken to read TRSR[2:0] before these bits are cleared.

**[1] Receiver in Hunt Mode (COP) —**

**COP** This bit is asserted after the receiver is reset or disabled. It indicates that the receiver is in the hunt mode, searching the data stream for a SYN sequence to establish character synchronization. The bit is negated automatically when character sync is achieved.

**[0] Receiver in Transparent Mode (BISYNC) —**

**COP** Indicates that a DLE-STx sequence was received and the receiver is operating in BISYNC transparent mode. Set two bit times after detection of STx in HSRL. See Figure 1 for receiver data path. Transparent mode operation is terminated and the bit is negated automatically when one of the terminators for transparent text mode is received (DLE-ETx/ETB/ITB/ENQ).

**Input and Counter/Timer Status Register (ICTSRA, ICTSRB)**

This register informs the CPU of status of the counter/timer and inputs. The logical-OR of bits [6:4] is presented in GSR[3] or GSR[7] for channels A and B, respectively. Unless otherwise specified, bits of this register are reset only:

1. By performing a write operation to the status register with the bits to be reset (ones in the accompanying data word for bits [6:4] only).
2. When the RESETN input is asserted (bits [7:4]) only.

**[7] Counter/Timing Running** — Set when the C/T is started by start C/T command and

reset when it is stopped by a stop C/T command.

**[6] Counter/Timer Zero Detect** — Set when the counter/timer reaches zero count, or when the bit length measurement is enabled (CTCR [2:0] = 011) and the RXD input has returned high. The assertion of this bit causes an interrupt to be generated if ICTCR[7] and the channel's master interrupt enable (ICR[1] or ICR[0]) are asserted.

**[5] Delta DCD** — The DCD input is sampled approximately every 6.8μs using the 32×, 4800 baud output from the BRG. After synchronizing with the sampling clock, at least two consecutive samples at the same level are required to establish the level. As a consequence, a change of state at the DCD input, lasting at least 17μs, will set this bit. The reset circuitry initializes the sampling circuits so that a change is not falsely indicated at power on time. The assertion of this bit causes an interrupt to be generated if IER[7] and the channel's master interrupt enable (ICR[1] or ICR[0]) are asserted.

**[4] Delta CTS/LC** — When not in loop mode, the CTS input is sampled approximately every 6.8μs using the 32×, 4800 baud output from the BRG. After synchronizing with the sampling clock, at least two consecutive samples at the same level are required to establish the level. As a consequence, a change of state at the CTS input, lasting at least 17μs, will set this bit. The reset circuitry initializes the sampling circuits so that a change is not falsely indicated at power on time. The assertion of this bit causes an interrupt to be generated if IER[7] and the channel's master interrupt enable (ICR[1] or ICR[0]) are asserted.

In SDLC loop mode, this bit is set upon transitions of the LC output. LC is asserted in response to the 'go on-loop' command when the receiver detects a zero followed by seven ones, and negated in response to the 'go off-loop' command when the receiver detects a sequence of eight ones.

**[3:0] Current State of DCD, CTS, GPI2, and GPI1 Inputs** — This field provides the current state of the channel's input pins. The bit's value is latched at the beginning of the read cycle.

**Interrupt Vector Register (IVR) and Modified Vector Register (IVRM)**

**[7:0] Register Content** — If ICR[2] = 0, the content of IVR register is output on the data bus when the DUSCC has issued an interrupt request and the responding interrupt acknowledgement (IACKN) is received. The value in the IVR is initialized to H'0F' on master reset. If 'vector includes status' is specified by

Dual Universal Serial Communications Controller (DUSCC) **SCN68562**

ICR[2] = 1, bits [2:0] or [4:2] (depending on ICR[3]), of the vector are modified as shown in Table 8 to indicate the highest priority interrupt currently active. The priority is programmable through the ICR. This modified vector is stored in the IVRM. When ICR[2] = 1, the content of the IVRM is output on to the data bus on the interrupt acknowledge. The vector is not modified, regardless of the value of ICR[2], if the CPU has not written an initial vector into this register.

Either the modified or unmodified vector can also be read by the CPU via a normal bus read cycle (see Table 1). The vector value is locked at the beginning of the IACK or read cycle until the cycle is completed.

**Interrupt Control Register (ICR)**

**[7:6] Channel A/B Interrupt Priority** — Selects the relative priority between channels A and B. The state of this bit determines the value of the interrupt vector (see Interrupt Vector Register). The priority within each channel, from highest to lowest, is as follows:

- 0 Receiver ready
- 1 Transmitter ready
- 2 Rx/Tx status
- 3 External or C/T status
- 00 Channel A has the highest priority. The DUSCC interrupt priorities from highest to lowest are as follows: A(0), A(1), A(2), A(3), B(0), B(1), B(2), B(3)
- 01 Channel B has the highest priority. The DUSCC interrupt priorities from highest to lowest are as follows: B(0), B(1), B(2), B(3), A(0), A(1), A(2), A(3)
- 10 Priorities are interleaved between channels, but channel A has the highest priority between events of equal channel priority. The DUSCC interrupt priorities from highest to lowest are as follows: A(0), B(0), A(1), B(1), A(2), B(2), A(3), B(3)

**Table 8. Interrupt Status Encoding**

IVRM [2:0]/ [4:2]	HIGHEST PRIORITY INTERRUPT CONDITION
000	Channel A receiver ready
001	Channel A transmitter ready
010	Channel A Rx/Tx status
011	Channel A external or C/T status
100	Channel B receiver ready
101	Channel B transmitter ready
110	Channel B Rx/Tx status
111	Channel B external or C/T status

- 11 Priorities are interleaved between channels, but channel B has the highest priority between events of equal channel priority. The DUSCC interrupt priorities from highest to lowest are as follows: B(0), A(0), B(1), A(1), B(2), A(2), B(3), A(3)

**[5:4] Vector Mode** — The value of this field determines the response of the DUSCC when the interrupt acknowledge (IACKN) is received from the CPU.

- 00 Vectored mode. Upon interrupt acknowledge, the DUSCC locks its current interrupt status until the end of the acknowledge cycle. If it has an active interrupt pending, it responds with the appropriate vector and then asserts DTACKN. If it does not have an interrupt, it propagates the acknowledge through its X2/IDCN output if this function is programmed in PCRA[7]. Otherwise, the IACKN is ignored. Locking the interrupt status at the leading edge of IACKN prevents a device at a high position in the interrupt daisy chain from responding to an IACK issued for a lower priority device while the acknowledge is being propagated to that device.
- 11 Non-vectored mode. The DUSCC ignores an IACK if one is received; the interrupt vector is not placed on the data bus. The internal interrupt status is locked when a read of the IVR or IVRM is performed. Except for the absence of the vector on the bus, the DUSCC performs as it does in vectored mode — the vector is prioritized and modified if programmed.

**[3] Vector Bits to Modify** — Selects which bits of the vector stored in the IVR are to be modified to indicate the highest priority interrupt pending in the DUSCC. See Interrupt Vector Register.

- 0 Modify bits 2:0 of the vector.
- 1 Modify bits 4:2 of the vector.

**[2] Vector Includes Status** — Selects whether the modified (includes status) (IVRM) or unmodified vector (IVR) is output in response to an interrupt acknowledge (see Interrupt Vector Register).

- 0 Unmodified vector.
- 1 Modified vector.

**[1] Channel A Master Interrupt Enable** —

- 0 Channel A interrupts are disabled.
- 1 Channel A interrupts are enabled.

**[0] Channel B Master Interrupt Enable** —

- 0 Channel B interrupts are disabled.
- 1 Channel B interrupts are enabled.

**General Status Register (GSR)**

This register provides a 'quick look' at the overall status of both channels of the DUSCC. A write to this register with 1s at the corresponding bit positions causes TxRDY (bits 5 and 1) and/or RxRDY (bits 4 and 0) to be reset. The other status bits can be reset only by resetting the individual status bits that they point to.

**[7] Channel B External or Counter/Timer Status** — This bit indicates that one of the following status bits is asserted: ICTSRB[6:4].

**[6] Channel B Receiver or Transmitter Status** — This bit indicates that one of the following status bits is asserted: RSRB[7:0], TRSRB[7:3].

**[5] Channel B Transmitter Ready** — The assertion of this bit indicates that one or more characters may be loaded into the channel B transmitter FIFO to be serialized by the transmit shift register. See description of OMR[4]. This bit can be asserted only when the transmitter is enabled. Disabling or resetting the transmitter negates TxRDY.

**[4] Channel B Receiver Ready** — The assertion of this bit indicates that one or more characters are available in the channel B receiver FIFO to be read by the CPU. See description of OMR[3]. RxRDY is initially reset (negated) by a chip reset or when a 'reset channel B receiver' command is invoked.

**[3] Channel A External or Counter/Timer Status** — This bit indicates that one of the following status bits is asserted: ICTSRA[6:4].

**[2] Channel A Receiver or Transmitter Status** — This bit indicates that one of the following status bits is asserted: RSRA[7:0], TRSRA[7:3].

**[1] Channel A Transmitter Ready** — The assertion of this bit indicates that one or more characters may be loaded into the channel A transmitter FIFO to be serialized by the transmit shift register. See description of OMR[4]. This bit can be asserted only when the transmitter is enabled. Disabling or resetting the transmitter negates TxRDY.

**[0] Channel A Receiver Ready** — The assertion of this bit indicates that one or more characters are available in the channel A receiver FIFO to be read by the CPU. See description of OMR[3]. RxRDY is initially reset (negated) by a chip reset or when a 'reset channel A receiver' command is invoked.

**Channel Command Register (CCRA, CCRB) —**

Commands to the DUSCC are entered through the channel command register. The format of that register is shown in Table 9. A

## Dual Universal Serial Communications Controller (DUSCC)

SCN68562

Table 9. Command Register Bit Format

CHANNEL COMMAND REG								
	BIT 7	BIT 6	BIT 5	BIT 4	BIT 3	BIT 2	BIT 1	BIT 0
(CCRA, CCRB)	00 = Transmitter CMD		don't care	don't care	Transmitter Command			
					0000 — reset Tx	0001 — reset TxCRC*	0010 — enable Tx	0011 — disable Tx
					0100 — transmit SOM (TSOM)	0101 — transmit SOM with PAD (TSOMP)	0110 — transmit EOM (TEOM)*	0111 — transmit ABORT/BREAK (TABRK)
					1000 — transmit DLE (TDLE)*	1001 — go active on poll	1010 — reset go active on poll	1011 — go on-loop
								1100 — go off-loop
								1101 — exclude from CRC*
	01 = Receiver CMD		don't care	don't care	Receiver Command			
0000 — reset Rx					0001 — reserved	0010 — enable Rx	0011 — disable Rx	
Counter/Timer Command								
0000 — start					0001 — stop	0010 — preset to FFFF	0011 — preset from CTPRH/CTPRL	
	10 = C/T CMD		don't care	don't care	DPLL Command			
0000 — enter search mode					0001 — disable DPLL	0010 — set FM mode	0011 — set NRZI mode	
0100 — reserved for test					0101 — reserved for test			
	11 = DPLL CMD		don't care	don't care				

**NOTE:**

\*FIFOed commands

read of this register returns the last invoked command (with bits 4 and 5 set to 1).

**Transmitter Commands**

- 0000 Reset transmitter. Causes the transmitter to cease operation immediately. The transmit FIFO is cleared and the TxD output goes into the marking state. Also clears the transmitter status bits (TRSR[7:4]) and resets the TxRDY status bit (GSR[1] or GSR[5] for channels A and B, respectively). The counter/timer and other registers are not affected.
- 0001 Reset transmit CRC. This command is appended to and FIFOed along with the next character loaded into the transmit FIFO. It causes the transmitter CRC generator to be reset to its initial state prior to beginning transmission of the appended character.
- 0010 Enable transmitter. Enables transmitter operation, conditioned by the state

- of the CTS ENABLE Tx bit, TPR[2]. Has no effect if invoked when the transmitter has previously been enabled.
- 0011 Disable transmitter. Terminates transmitter operation and places the TxD output in the marking state at the next occurrence of a transmit FIFO empty condition. All characters currently in the FIFO, or any loaded subsequently prior to attaining an empty condition, will be transmitted.
- 0100 Transmit start of message. Used in COP and BOP modes to initiate transmission of a frame after the transmitter is first enabled, prior to sending the contents of the FIFO. Can also be used to precisely control the number of SYN/FLAGS at the beginning of transmission or in between frames.
- When the transmitter is first enabled, transmission will not begin until this

command (or the transmit SOM with PAD command, see below) is issued. The command causes the SYN (COP) or FLAG (BOP) pattern to be transmitted. SEND SOM ACK (TRSR[4]) is set when transmission of the SYN/FLAG begins. The CPU may then reinvoke the command if multiple SYN/FLAGS are to be transmitted. Transmission of the FIFO characters begins when the command is no longer reinvoiced. If the FIFO is empty, SYN/FLAGS continue to be transmitted until a character is loaded into the FIFO, but the status bit (TSR[4]) is not set. Insertion of SYN/FLAGS between frames can be accomplished by invoking this command after the frame complete status bit (TRSR[5]) has been asserted in response to transmission of the end-of-message sequence.

# Dual Universal Serial Communications Controller (DUSCC)      SCN68562

2

- 0101 Transmit start of message with opening PAD. Used in COP and BOP modes after the transmitter is first enabled to send a bit pattern for DLL synchronization prior to transmitting the opening SYN (COP) or FLAG (BOP). The SYN/FLAG is sent at the next occurrence of a transmit FIFO empty condition. All characters currently in the FIFO, or any loaded subsequently prior to attaining an empty condition, will be transmitted. While the PAD characters are transmitted, the character length is set to 8 bits, (regardless of the programmed length), and parity generation (COP), zero insertion (BOP), and LRC/CRC accumulation are disabled. SEND SOM ACK (TRSR[4]) is set when transmission of the SYN/FLAG begins. The CPU may then invoke the transmit SOM command if multiple SYN/FLAGS are to be transmitted.
- The TSOM/TSOMP commands, described above, are sampled by the controller in alternate bit times of the transmitter clock. As a consequence, the first bit time of a COP/BOP frame will be transmitted on the TxD pin, after a maximum of three bit times, after the command is issued. (The additional 1-bit delay in the data path is due to the data encoding logic.)
- 0110 Transmit end-of-message. This command is appended to the next character loaded into the transmit FIFO. It causes the transmitter to send the end-of-message sequence (selected FCS in COP modes, FCS-FLAG in BOP modes) after the appended character is transmitted. Frame complete (TRSR[5]) is set when transmission of the FCS begins. This command is also asserted automatically if the TEOM on zero count or done control bit (TPR[4]) is asserted, and the counter/timer is programmed to count transmitted characters when the character which causes the count to go to zero is loaded into the transmit FIFO.
- 0111 Transmit Abort BOP/Transmit Break ASYNC. In BOP modes, causes an abort (eight ones) to be transmitted after transmission of the character currently in the shift register is completed. The transmitter then sends MARKs or FLAGs depending on the state of underrun control (TPR[7:6]). Send SOM/abort ack (TRSR[4]) is set when the transmission of the abort begins. If the command is reasserted before transmission of the previous ABORT is completed, the process will be repeated. This can be used to send the idle sequence. The 'transmit SOM' command must be used to initiate transmission of a new message. In either mode, invoking this command causes the transmit FIFO to be flushed (characters are not transmitted).
- In ASYNC mode, causes a break (space) to be transmitted after transmission of the character currently in the shift register is completed. Send break ack (TRSR[4]) is set when the transmission of the break begins. The transmitter keeps track of character times. If the command is reasserted, send break ack will be set again at the beginning of the next character time. The user can use this mechanism to control the length of the break in character time multiples. Transmission of the break is terminated by issuing a 'reset Tx' or 'disable Tx' command.
- 1000 Transmit DLE. Used in COP modes only. This command is appended to and FIFOed with the next character loaded into the transmitter FIFO. It causes the transmitter to send a DLE, (EBCDIC H'10', ASCII H'10') prior to transmitting the appended character. If the transmitter is operating in BLSYNC transparent mode, the transmitter control logic automatically causes a second DLE to be transmitted whenever a DLE is detected at the top of the FIFO. In this case, the TDLE command should not be invoked. An extra (third) DLE, however, will not be sent if the transmit DLE command is invoked.
- 1001 Go active on poll. Used in BOP loop mode only. Causes the transmitter, if it is enabled, to begin sending when an EOP sequence consisting of a zero followed by seven ones is detected. The last one of the EOP is changed to zero, making it another FLAG, and then the transmitter operates as described in the detailed operation section. The loop sending status bit (TRSR[6]) is asserted concurrent with the beginning of transmission.
- 1010 Reset go active on poll. Clears the stored 'go active on poll' command.
- 1011 Go on-loop. Used in BOP loop mode to control the assertion of the LC\_N output. This output provides the means of controlling external loop interface hardware to go on-loop and off-loop. When the command is asserted, the DUSCC will look for the receipt of seven contiguous ones, at which time it will assert the LC\_N output and set the delta DCD/LC status bit (ICTSR[4]). This allows the DUSCC to break into the loop without affecting loop operation. This command must be used to initiate loop mode operation.
- 1100 Go off-loop. Used in BOP loop mode to control the negation of the LC\_N output. This output provides the means of controlling external loop interface hardware to go on-loop and off-loop. When the command is asserted, the DUSCC will look for the receipt of eight contiguous ones, at which time it will negate the LC\_N output and set the delta DCD/LC status bit (ICTSR[4]). This allows the DUSCC to get off the loop without affecting loop operation. This command is normally used to terminate loop mode operation.
- 1101 Exclude from CRC. This command is appended to and FIFOed along with the next character loaded into the transmit FIFO. It causes the transmitter CRC generator to be disabled while the appended character is being transmitted. Thus, that character is not included in the CRC accumulation.

## Receiver Commands

- 0000 Reset Receiver. Causes the receiver to cease operation, clears the receiver FIFO, and clears the receiver status (RSR[7:0], TRSR[3:0]), and either GSR[0] or GSR[4] for channels A and B, respectively). The counter/timer and other registers are not affected.
- 0001 Reserved.
- 0010 Enable receiver. Causes receiver operation to begin, conditioned by the state of the DCD ENABLE Rx bit, RPR[2]. Receiver goes into START, SYN, or FLAG search mode depending on channel protocol mode. Has no effect if invoked when the receiver has previously been enabled.
- 0011 Disable receiver. Terminates operation of the receiver. Any character currently being assembled will be lost. Does not affect FIFO or any status.

## Counter/Timer Commands

- 0000 Start. Starts the counter/timer and prescaler.
- 0001 Stop. Stops the counter/timer and prescaler. Since the command may be asynchronous with the selected clock source, the counter/timer and/

# Dual Universal Serial Communications Controller (DUSCC)      SCN68562

- or prescaler may count one or more additional cycles before stopping.
- 0010 Preset to FFFF. Presets the counter timer to H'FFFF' and the prescaler to its initial value. This command causes the C/T output to go low.
- 0011 Preset from CTPRH/CTPRL. Transfers the current value in the counter/timer preset registers to the counter/timer and presets the prescaler to its initial value. This command causes the C/T output to go low.

## Digital Phase-Locked Loop Commands

- 0000 Enter Search Mode. This command causes the DPLL counter to be set to the value 16 and the clock output will be forced high. The counter will be disabled until a transition on the data line is detected, at which point it will start incrementing and the clock output will go from high to low. After the counter reaches a count of 31, it will reset to zero and cause the clock output to go from low to high. The DPLL will then continue normal operation. This allows the DPLL to be locked onto the data without pre-frame transitions. This command should not be used if the DPLL is programmed to supply the clock for the transmitter and the transmitter is active.
- 0001 Disable DPLL. Disables operation of the DPLL.
- 0010 Set FM Mode. Sets the DPLL to the FM mode of operation, used when FM0, FM1, or Manchester (NRZ) is selected by CMR1[7:6].
- 0011 Set NRZI Mode. Sets the DPLL to the NRZI mode of operation, used when NRZ or NRZI is selected by CMR1[7:6].
- 0100 Reserved for test
- 0101 Reserved for test

## DETAILED OPERATION

### Interrupt Control

A single interrupt output (IRQN) is provided which is activated upon the occurrence of any of the following conditions:

- Channel A external or C/T special condition
- Channel B external or C/T special condition
- Channel A Rx/Tx error or special condition
- Channel B Rx/Tx error or special condition
- Channel A TxRDY

Channel B TxRDY

Channel A RxRDY

Channel B RxRDY

Each of the above conditions occupies a bit in the general status register (GSR). If ICR[2] is set, the eight conditions are encoded into three bits which are inserted into bits [2:0] or [4:2] of the interrupt vector register. This forms the content of the IVRM during an interrupt acknowledge cycle. Unmodified and modified vectors can be read directly through specified registers. Two of the conditions are the inclusive OR of several other maskable conditions:

- Ext or C/T special condition: Delta DCD, delta CTS or C/T zero count (ICTSR[6:4]).
- Rx/Tx error or special condition: Any condition in the receiver status register (RSR[7:0]) or a transmitter or DPLL condition in the transmitter and receiver status register (TRSR[7:3]).

The TxRDY and RxRDY conditions are defined by OMR[4] and OMR[3], respectively. Also associated with the interrupt system are the interrupt enable register (IER), one bit in the counter/timer control register (CTCR), and the interrupt control register (ICR).

The IER is programmed to enable specified conditions or groups of conditions to cause an interrupt by asserting the corresponding bit. A negated bit prevents an interrupt from occurring when the condition is active and hence masks the interrupt. In addition to the IER, CTCR[7] could be programmed to enable or disable an interrupt upon the C/T zero count condition. The interrupt priorities within a channel are fixed. Priority between channels is controlled by ICR[7:6]. Refer to Table 8 and ICR[7:6].

The ICR contains the master interrupt enables for each channel (ICR[1] and ICR[0]) which must be set if the corresponding channel is to cause an interrupt. The CPU vector mode is specified by ICR[5:4] which selects either vectored or non-vectored operation. If vectored mode is selected, the content of the IVR or IVRM is placed on the data bus when IACK is activated. If ICR[2] is set, the content of IVRM is output which contains the content of IVR and the encoded status of the interrupting condition.

Upon receiving an interrupt acknowledge, the DUSCC locks its current interrupt status until the end of the acknowledge cycle. If it has an active interrupt pending, it responds with the appropriate vector and then asserts DTACKN. If it does not have an interrupt, it propagates the acknowledge through its X2/IDCN output if this function is programmed in PCRA[7]; otherwise, the IACKN is ignored. Locking the interrupt status at the leading

edge of IACKN prevents a device at a high position in the interrupt daisy chain from responding to an IACK issued for a lower priority device while the acknowledge is being propagated to that device.

### DMA Control

The DMA control section provides the interface to allow the DUSCC to operate with an external DMA controller. One of four modes of DMA can be programmed for each channel independently via CMR2[5:3]:

- Half-duplex single address. In this mode, a single pin provides both DMA read and write requests. Acknowledgement of the requests is via a single DMA acknowledge pin. The data transfer is accomplished in a single bus cycle — the DMA controller places the memory address of the source or destination of the data on the address bus and then issues the acknowledge signal, which causes the DUSCC to either write the data into its transmit FIFO (write request) or to output the contents of the top of the receive FIFO (read request). The cycle is completed when the DTCN input is asserted by the DMA controller. This mode can be used when channel operation is half-duplex (e.g., BISOYNC). It allows a single DMA channel to service the receiver and transmitter.
- Half-duplex dual address. In this mode, a single pin provides both DMA read and write requests. Acknowledgement of the requests is via normal bus read and write cycles. The data transfer requires two bus cycles — the DMA controller acquires the data from the source (memory for a Tx DMA or DUSCC for a Rx DMA) on the first cycle and deposits it at the destination (DUSCC for a Tx DMA or memory for a Rx DMA) on the second bus cycle. This mode is used when channel operation is half-duplex (e.g., BISOYNC) and allows a single DMA channel to service the receiver and transmitter.
- Full-duplex single address. This mode is similar to half-duplex single address mode but provides separate request and acknowledge pins for the receiver and transmitter.
- Full-duplex dual address. This mode is similar to half-duplex dual address mode but provides duplex dual address mode but provides separate request pins for the receiver and transmitter.

Figures 4 through 7 describe operation of the DUSCC in the various DMA environments. Table 10 summarizes pins used for the DMA request and acknowledge function for the transmitter and receiver for the different DMA modes.



# Dual Universal Serial Communications Controller (DUSCC)      SCN68562

**2**

**Table 10. DMA REQ and ACK Pins for Operational Modes**

FUNCTION	HALF DUPLEX SINGLE ADDR DMA	HALF DUPLEX DUAL ADDR DMA	FULL DUPLEX SINGLE ADDR DMA	FULL DUPLEX DUAL ADDR DMA
RCVR REQ	RTxDRQ_N	RTxDRQ_N	RTxDRQ_N	RTxDRQ_N
TRAN REQ	Same as RCVR REQ	Same as RCVR REQ	TxDRQ_N	TxDRQ_N
RCVR ACK	RTxDAK_N	Normal read RCVR FIFO	RTxDAK_N	Normal read RCVR FIFO
TRAN ACK	Same as RCVR ACK	Normal write TRAN FIFO	TxDAK_N	Normal write TRAN FIFO

The DMA request signals are functionally identical to the TxRDY and RxRDY status signals for each serial channel except that in DMA the signals are negated on the leading edge of the acknowledge signal when the subsequent transfer causes the FIFO to become full (transmitter request) or empty (receiver request). In non DMA operation TxRDY and RxRDY signals are negated only after the transfer is completed. The DMA read request can be programmed through OMR[3] be asserted either when any character is in the receive FIFO or only when the receive FIFO is full. Likewise, the DMA write request can be programmed through OMR[4] to be asserted either when the transmit FIFO is not full or only when the transmit FIFO is empty (the transmitter must be enabled for a DMA request to be asserted). The request signals are negated when the respective data transfer cycle is completed. When the serial channel is not operating in DMA mode, the request and acknowledge pins for the channel can be programmed for other functions (see pin descriptions).

**DMA DONEN Operation**

As an input, DONEN is asserted by the DMA controller concurrent with the corresponding DMA acknowledge to indicate to the DUSCC that the character being transferred into the TxFIFO is the last character of the transmission frame. In synchronous modes, the DUSCC can be programmed through TPR[4] to automatically transmit the frame termination sequence (e.g., FCS-FLAG in BOP mode) upon receipt of this signal.

As an output, DONEN is asserted by the DUSCC under the following conditions:

- a. In response to the DMA acknowledge for a receiver DMA request if the FIFOed RECEIVED EOM status bit (RSR[7]) is set for the character being transferred.
- b. In response to the DMA acknowledge for a transmitter DMA request if the counter/timer has been programmed to count transmitted characters and the terminal count has occurred.

**Block Transfers Using DTACK**

The DTACKN line may be used to synchronize data transfers to and from the DUSCC

utilizing a 'wait' state. Either the receiver or the transmitter or both may be programmed for this mode of operation, independently for each channel, via CMR2[5:3].

In this mode, if the CPU attempts a write to the transmit FIFO and an empty FIFO position is not available, the DTACK line will remain negated until a position empties. The data will then be written into the FIFO and DTACKN will be asserted to signify that the transfer is complete.

Similarly, a read of an empty receive FIFO will be held off until data is available to be transferred. Potentially, this mode can cause the microcomputer system to hang up if, for example, a read request was made and no further data was available.

**Timing Circuits**

The timing block for each channel consists of a crystal oscillator, a bit rate generator (BRG), a digital phase locked loop (DPLL) and a 16-bit counter/timer (C/T) (see Figure 8).

**Crystal Oscillator**

The crystal oscillator operates directly from a crystal (normally 14.7456MHz if the internal BRG is to be used) connected across the X1/CLK and X2/IDCN pins with a minimum of external components. If an external clock of the appropriate frequency is available, it may be connected to the X1/CLK pin. This signal is divided by two to provide the internal system clock (a maximum of 16MHz input is allowed).

**Bit Rate Generator**

The BRG operates from the oscillator or external clock and is capable of generating 16 bit rates. These are available to the receiver, transmitter, DPLL, and C/T. The BRG output is at 32x the base bit rate. Since all sixteen rates are generated simultaneously, each receiver and transmitter may select its bit rate independently. The transmitter and receiver timing registers include a 4-bit field for this purpose (TTR[3:0], RTR[3:0]).

**Digital Phase-Locked Loop**

Each channel of the DUSCC includes a DPLL used in synchronous modes to recover clock information from a received data stream. The DPLL is driven by a clock at nominally 32

times the data rate. This clock can be programmed, via RTR (7:4), to be supplied from an external input, from the receiver BRG, from the C/T, or directly from the crystal oscillator.

The DPLL uses this clock, along with the data stream to construct a data clock which may then be used as the DUSCC receive clock, transmit clock, or both. The output of the DPLL is a square wave at 1x the data rate. The derived clock can also be programmed to be output on a DUSCC pin; only the DPLL receiver output clock is available at the TRxC pin. Four commands are associated with DPLL operation: Enter search mode, set FM mode, set NRZI mode, and disable DPLL. The commands are described in the command register description. Waveforms associated with the DPLL are illustrated in Figure 9.

**DPLL NRZI Mode Operation**

This mode is used with NRZ and NRZI data encoding. With this type of encoding, the transitions of the data stream occur at the beginning of the bit cell. The DPLL has a six-bit counter which is incremented by a 32x clock. The first edge detected during search mode sets the counter to 16 and begins operation. The DPLL output clock then rises at a count of 0 and falls at 16. Data is sampled on the rising edge of the clock. When a transition in the data stream is detected, the count length is adjusted by one or two counts, depending on the counter value when the transition occurs (see Table 11). A transition detection at the rollover point (third column in Figure 11) is treated as a transition occurring at zero count.

The count length adjustments cause the rising edge of the DPLL output clock to converge to the nominal center of the bit cell. In the worst case, which occurs when a DPLL pulse is coincident with the data edge, the DPLL converges after 12 data transitions.

For NRZ encoded data, a stream of alternating ones and zeros should be used as a synchronizing pattern. For NRZI encoded data, a stream of zeros should be used.

**Table 11. NRZI Mode Count Length**

COUNT WHEN TRANSITION DETECTED	COUNT LENGTH ADJUSTMENT	COUNTER RESET AFTER COUNT REACHES
0 - 7	-2	29
8 - 15	-1	30
16 - 23	+1	32
24 - 30	+2	33
None detected	0	31

## Dual Universal Serial Communications Controller (DUSCC)

SCN68562

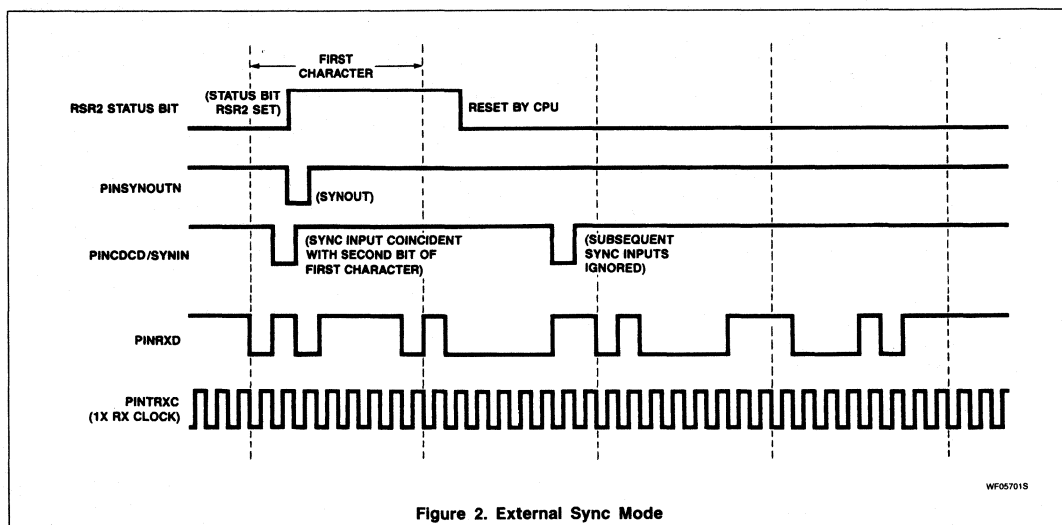

Figure 2. External Sync Mode

WF05701S

**DPLL FM Mode Operation**

FM operation is used with FM0, FM1, and Manchester data encoding. With this type of encoding, transitions in the data stream always occur at the beginning of the bit cell for FM0 and FM1, or at the center of the bit cell for Manchester. The DPLL 6-bit counter is incremented by a  $32\times$  clock. The first edge detected during search mode sets the counter to 16 and begins operation. The DPLL receiver clock then rises on a count of 8 and falls on 24. (The DPLL transmitter clock output falls on a count of 16. It rises on a count of 0 if a transition has been detected between counts of 16 and 23. For other cases, it rises 1/2 count of the  $32\times$  input clock sooner.) This provides a  $1\times$  clock with edges positioned at the nominal centers of the two halves of the bit cell. The transition detection circuit is enabled between counts of 8 and 23, inclusive. When a transition is detected, the count length is adjusted by one, depending on when the transition occurs (see Table 12).

Table 12. FM Mode Count Length

COUNT WHEN TRANSITION DETECTED	COUNT LENGTH ADJUSTMENT	COUNTER RESET AFTER COUNT REACHES
8 - 15	- 1	30
16 - 23	+ 1	32
24 - 7	Disabled	
None detected	0	31

If a transition is not detected for two consecutive data bits, the DPLL is forced into search mode and the DPLL error status bit (TRSR [3]) is asserted. This feature is disabled when the DPLL output is used only as the transmitter clock.

To prevent the DPLL from locking on the wrong edges of the data stream, an opening PAD sequence should be transmitted. For FM0, a stream of at least 16 ones should be sent initially. For FM1, a minimum stream of 16 zeros should be sent and for Manchester encoding the initial data stream should consist of alternating ones and zeros.

**Counter/Timer**

Each channel of the DUSCC contains a counter/timer (C/T) consisting of a 16-bit down counter, a 16-bit preset register, and associated control circuits. Operation of the counter/timer is programmed via the counter/timer control register (CTCR). There are also four commands associated with C/T operation, as described in the Command Description section.

The C/T clock source, clock prescaling, and operating mode are programmed via CTCR[2:0], CTCR[4:3], and CTCR[6] respectively. The preset register is loaded with a minimum of 2 by the CPU and its contents can be transferred into the down counter by a command, or automatically upon reaching terminal count if CTCR[6] is negated. Commands are also available to stop and start the C/T and to preset it to an initial value of FFFF. Counting is triggered by the falling edge of the clocking input. The C/T zero count status bit, ICTSR[6], is set when the

C/T reaches the terminal count of zero and ICTSR[7] indicates whether the counter is currently enabled or not.

An interrupt is generated upon reaching zero count if CTCR[7] and the channel's master interrupt enable are asserted. The output of the C/T can be programmed to be output on the channel's RTxC or TRxC pin (via PCR[4:0]) as either a single pulse or a square wave, as programmed in CTCR[5]. The contents of the C/T can be read at any time by the CPU, but the C/T should normally be stopped before this is done. Several C/T operating modes can be selected by programming of the counter/timer control register. Typical applications include:

1. Programmable divider. The selected clock source, optionally prescaled, is divided by the contents of the preset register. The counter automatically reloads itself each time the terminal count is reached. In this mode, the C/T may be programmed to be used as the Rx or Tx bit rate generator, as the input to the DPLL, or it may be output on a pin as either a pulse or a square wave. The C/T interrupt should be disabled in this mode.
2. Periodic interrupt generator. This mode is similar to the programmable divider mode, except that the C/T interrupt is enabled, resulting in a periodic interrupt to the CPU.
3. Delay timer. The counter is preset from the preset register and a clock source, optionally prescaled, is selected. An interrupt is generated upon reaching terminal count. The C/T continues counting

# Dual Universal Serial Communications Controller (DUSCC)

SCN68562

2

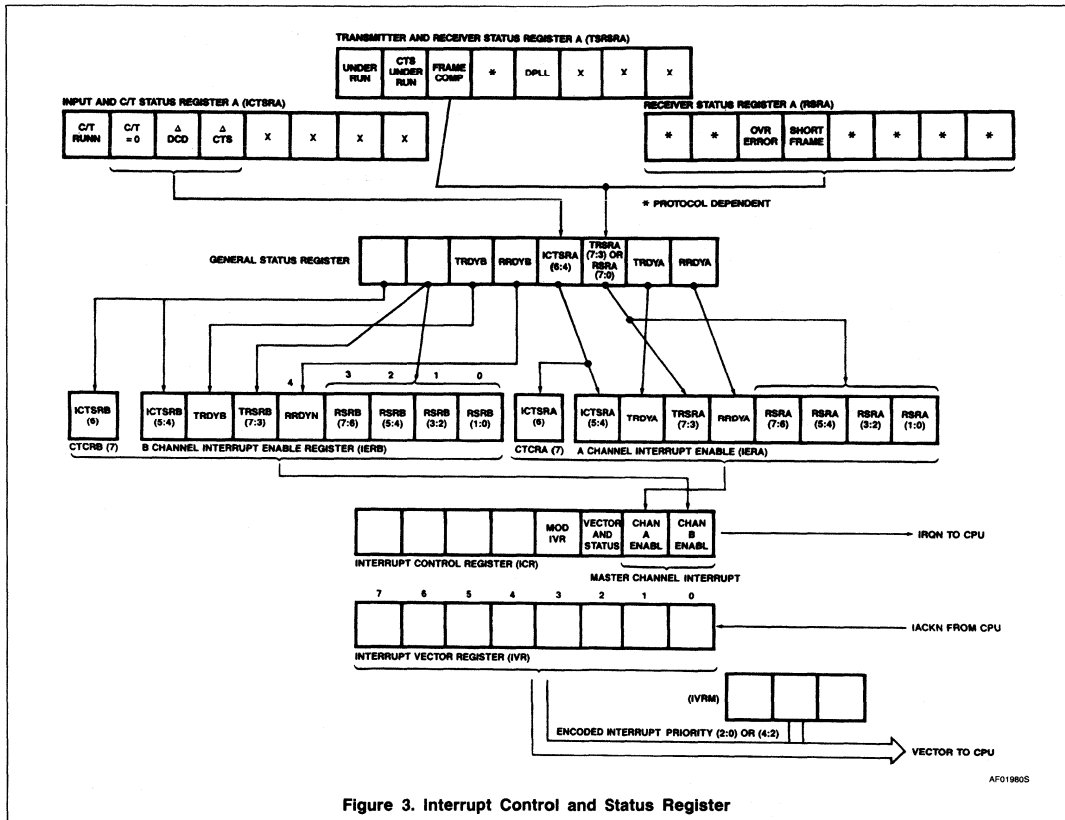

Figure 3. Interrupt Control and Status Register

without reloading itself and its contents may be read by the CPU to allow additional delay past the zero count to be determined.

4. Character counter. The counter is preset to FFFF by command and the clock source becomes the internal signal used to control loading of the Rx or Tx characters. This operation is selected by CTCR\_ [2:0]. The C/T counts characters loaded into the Rx FIFO by the receiver or loaded into the transmit FIFO by the CPU respectively. The current character count can be determined by the CPU by reading the contents of the C/T and taking its ones complement. Optionally, a preset number may be loaded into the counter and an interrupt generated when the count is exhausted. When counting Tx characters, the terminal count condition

can be programmed through TPR\_ [4] to cause an end of message sequence to be transmitted. When counting received characters, the FIFOed EOM status bit is asserted when the character which causes the count to go to zero is loaded into the receive FIFO. The channel's 'reset Tx' or 'reset Rx' commands have no effect on the operation of the C/T.

5. External event counter. The counter is preset to FFFF by command and an external clock source is selected. The current count can be determined by the CPU by reading the contents of the C/T and taking its ones complement. Optionally, a preset number may be loaded into the counter and an interrupt generated when the count is exhausted.
6. Bit length measurement. The counter is preset to FFFF by command and the X1/

CLK/4 clock input gated by Rx mode (optionally prescaled) is programmed. The C/T starts counting when RxD goes low and stops counting when RxD goes high. At this time, ICTSR[6] = 1 is set and an interrupt (if enabled) is generated. The resulting count in the counter can be read by the CPU to determine the bit rate of the input data. Normally this function is used for asynchronous operation.

## Communication Channels A and B

Each communication channel of the DUSCC is a full-duplex receiver and transmitter that supports ASYNC, COP, and BOP transmission formats. The bit rate clock for each receiver and transmitter can be selected independently to come from the bit rate generator, C/T, DPLL, or an external input (such as a modem generated clock).

# Dual Universal Serial Communications Controller (DUSCC)

SCN68562

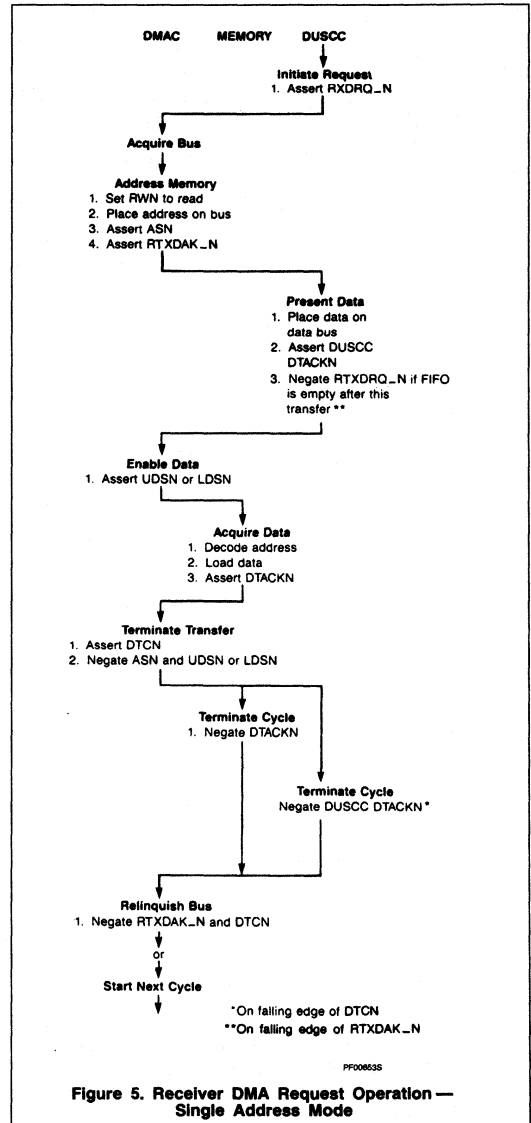
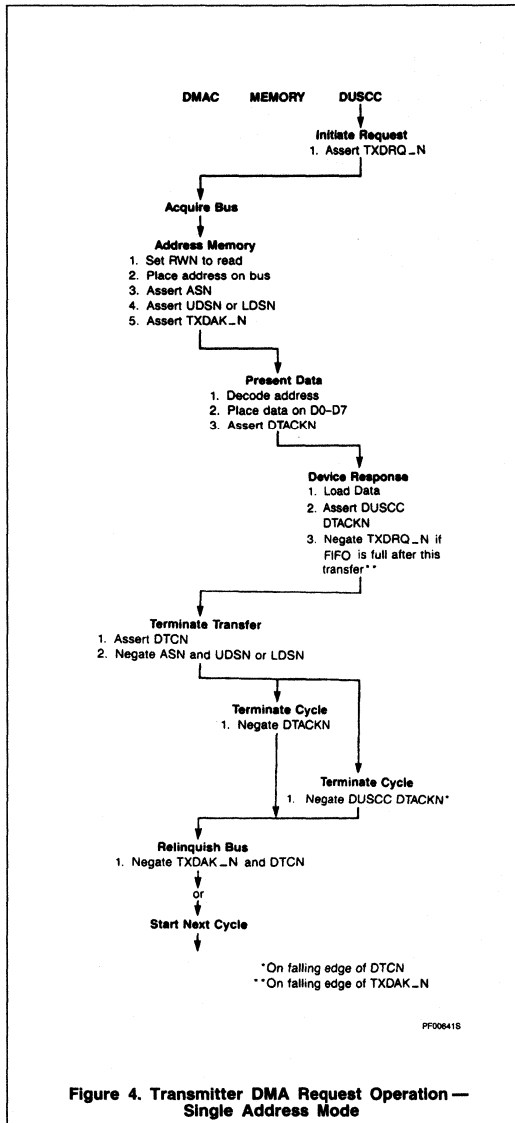

Dual Universal Serial Communications Controller (DUSCC)

SCN68562

**2**

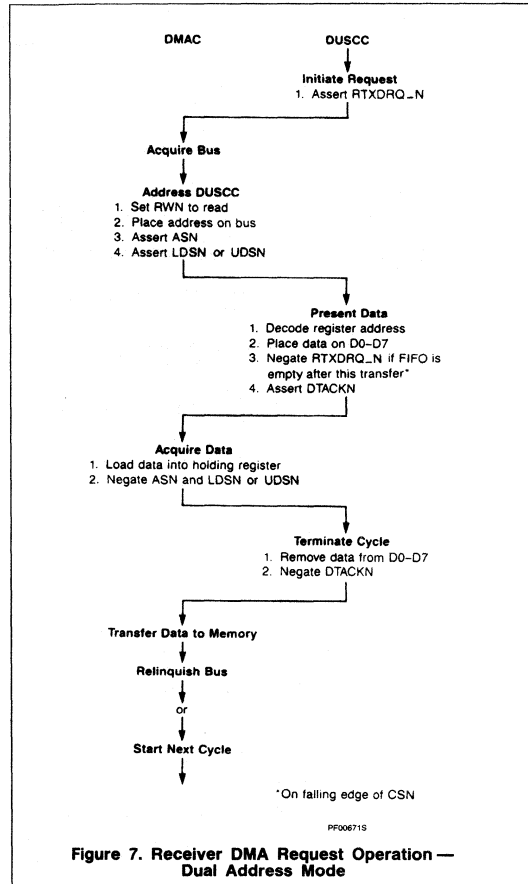
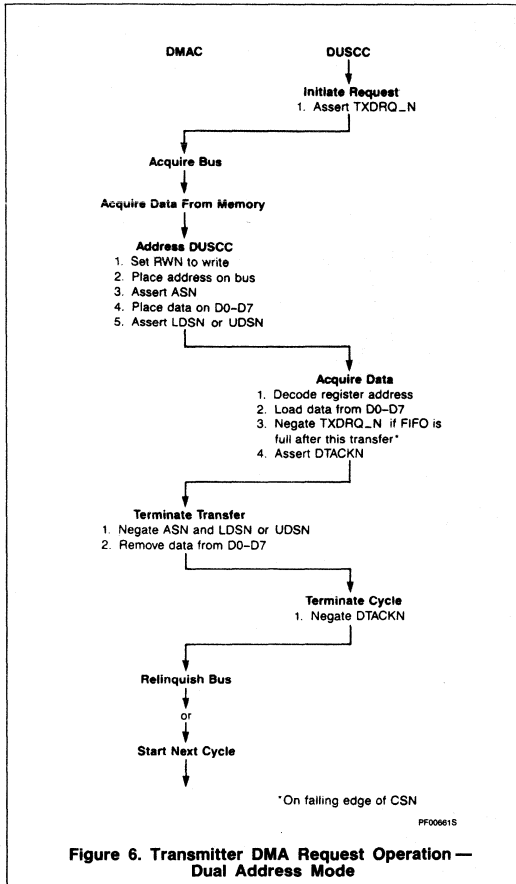

# Dual Universal Serial Communications Controller (DUSCC)

SCN68562

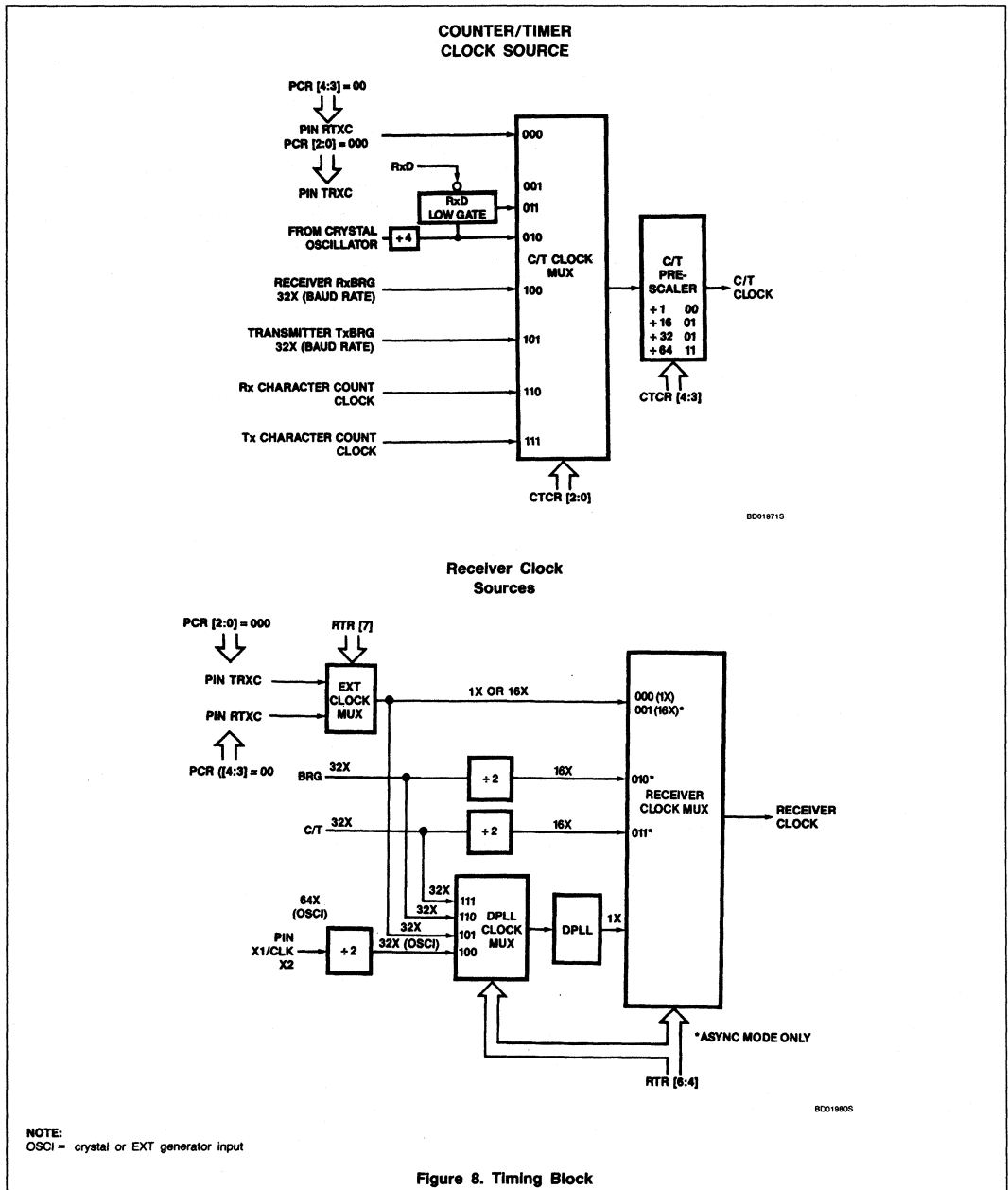

Figure 8. Timing Block

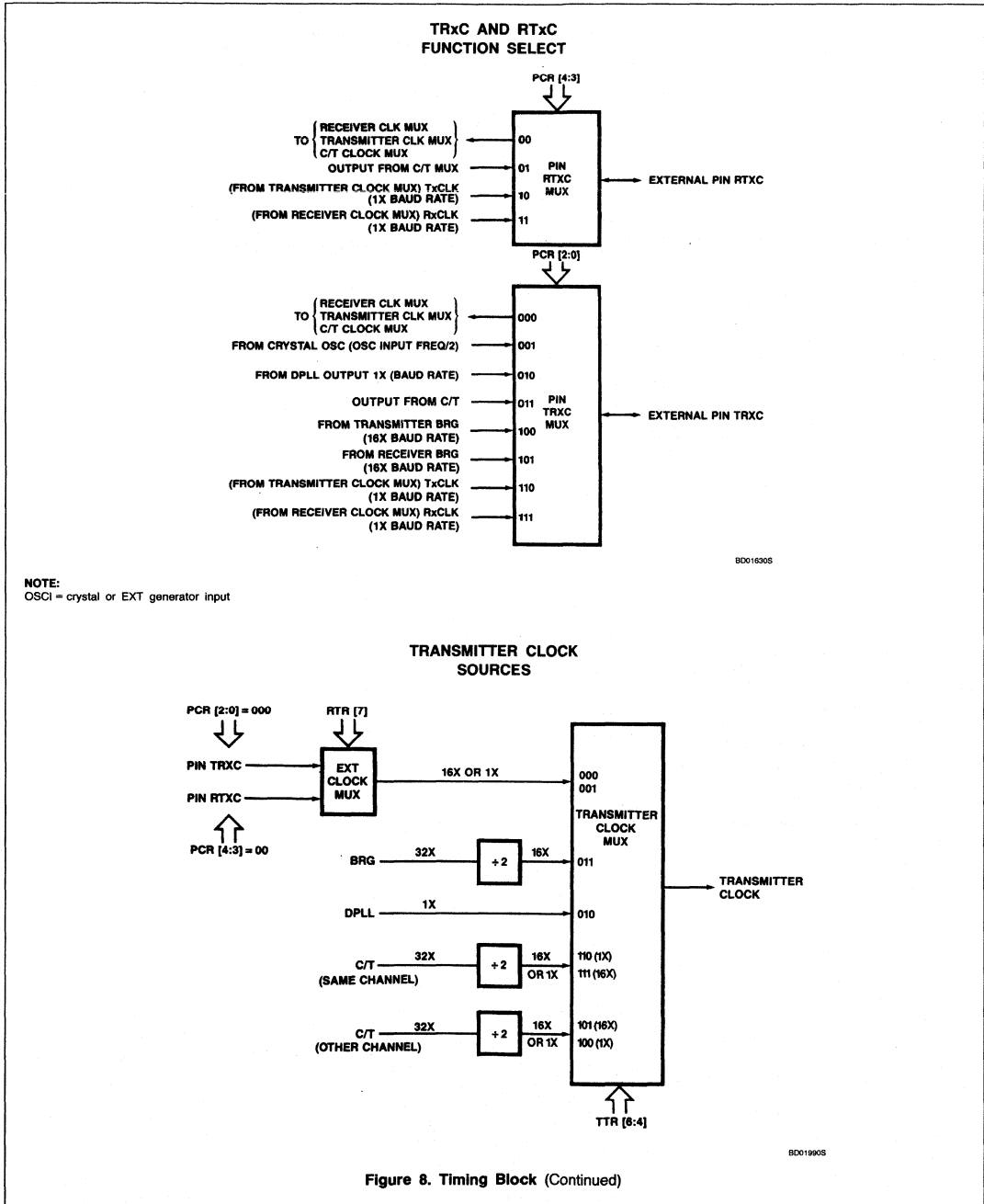

Figure 8. Timing Block (Continued)

## Dual Universal Serial Communications Controller (DUSCC) SCN68562

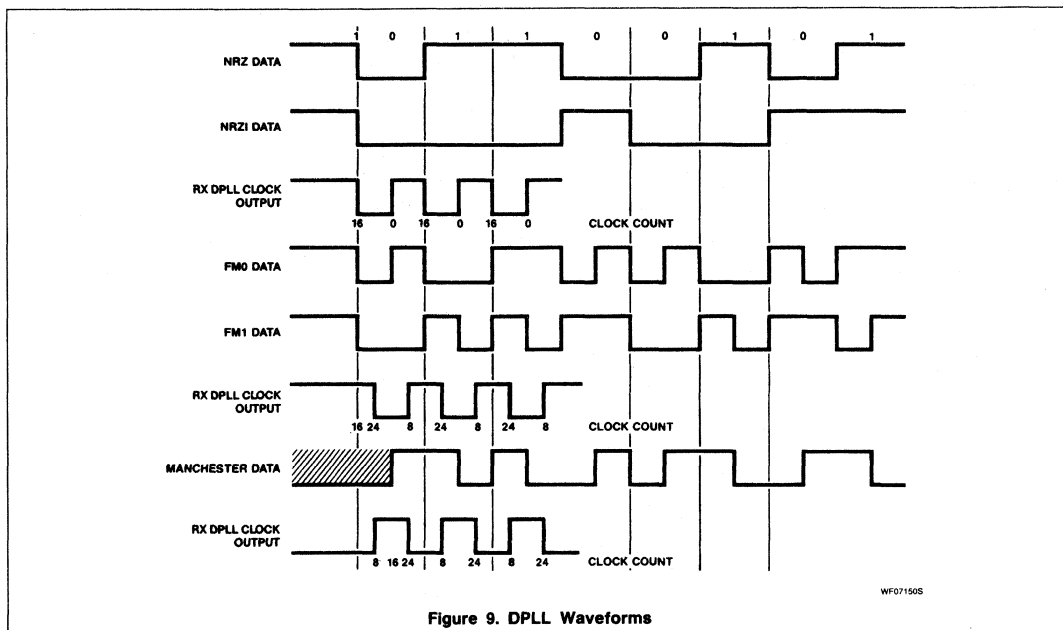

Figure 9. DPLL Waveforms

WF071505

## TRANSMITTER

### Transmitter TxFIFO and TxRDY

The transmitter accepts parallel data from the data bus and loads it into the TxFIFO, which consists of four 8-bit holding registers. This data is then moved to the transmitter shift register, TxSR, which serializes the data according to the transmission format programmed. The TxSR is loaded from the TxFIFO, from special character logic, or from the CRC/LRC generator. The LSB is transmitted first, which requires right justification of characters by the CPU. TxRDY (GSR[5] or GSR[1]) and underrun (TRSR[7]) indicate the state of the TxFIFO. The TxFIFO may be addressed at any of four consecutive locations (see Table 1) to allow use of multiple byte word instructions. A write to any valid address always writes data to the next empty FIFO location.

TxRDY is set when the transmitter is enabled and there is an empty position in the TxFIFO (OMR[4] = 0) or when the TxFIFO becomes empty (OMR[4] = 1). The CPU may reset TxRDY through a status reset write cycle. If this is done, it will not be reasserted until a character is transferred to the TxSR (OMR[4] = 0) or when the TxFIFO becomes empty again (OMR[4] = 1). The assertion of TxRDY, enabling of the IER [6] and the enabling of the channel master interrupt ICR [0] or [1] allow an interrupt to be generated.

If DMA operation is programmed, either RTxDRN (half-duplex) or TxDRQN (full-duplex) follows the state of TxRDY if the transmitter is enabled. These operations differ from normal ready in that the request signal is negated on the leading edge of the DMA acknowledge signal when the subsequent transfer causes the transmit FIFO to become full, while the TxRDY signal is negated only after the transfer is completed. Underrun status TRS[7] set indicates that one or more data characters (not PAD characters) have been transmitted and the TxFIFO and TxSR are both empty.

In 'wait on Tx', a write to a full FIFO causes the write cycle to be extended until a FIFO position is available. DTACKN is asserted to acknowledge acceptance of the data. In non-wait modes, if an attempt is made to load data into a full TxFIFO, the TxFIFO data is preserved and the overrun data character(s) is lost. A normal DTACKN will be issued, and no indication of this occurrence is provided. The transmitter is enabled by the enable transmitter command. When the disable transmitter command is issued, the transmitter continues to operate until the TxFIFO becomes empty. The TxRDY does not become valid until the transmitter is enabled. Characters can be loaded into the FIFO while disabled. However, if the FIFO is full when the transmitter is enabled, TxRDY is not asserted.

### TxRTS Control

If TxRTS CONTROL, TPR[3], is programmed, the channel's RTS output is negated five bit times after the last bit (stop bit in ASYNC mode) of the last character is transmitted. RTS is normally asserted and negated by writing to OMR[0]. The assertion of TPR[3] causes RTS to be reset automatically (if the transmitter is not enabled) after all characters in the transmitter FIFO (if any) are transmitted and five bit times after the 'last character' is shifted out. This feature can be used to automatically terminate the transmission of a message as follows:

- Program auto-reset mode: TPR[3] = 1.
- Enable transmitter.
- Assert RTS\_N: OMR[0] = 1.
- Send message.
- Disable transmitter after the last character is loaded into the TxFIFO.
- The last character will be transmitted and OMR[0] will be reset five bit times after the last bit, causing RTS\_N to be negated. The TxD output will remain in the marking state until the transmitter is enabled again.

The 'last bit' in ASYNC is simply the last stop bit of the character. In BOP and COP, the last character is defined either explicitly by either appending it with TEOM or implicitly through the selection of the frame underrun control



# Dual Universal Serial Communications Controller (DUSCC)      SCN68562

sequence, TPR[7:6] (transmitter parameter register). Table 13 summarizes the relationship of the selected underrun sequence and the protocol mode.

### Tx CTS Operation

If CTS enable Tx, TPR[2], is set, the CTSN input must be asserted for the transmitter to operate. Changes in CTSN while a character is being transmitted do not affect transmission of that character. However, if the CTS input becomes negated when TPR[2] is set and the transmitter is enabled and ready to start sending a new character, CTS underrun, TRSR[6], is asserted and the TxD output is placed in the marking (high) state. In ASYNC mode, operation resumes when CTSN is asserted again. In COP and BOP modes, the transmission of the message is terminated and operation of the transmitter will not resume until CTS is asserted and a TSOM or TSOMP command is invoked. Prior to issuing the command and retransmitting the message, the transmitter must be reset. After a change-of-state CTS is established by the input sampling circuits (refer to the description of ICTSR[4]), it is sampled by the Tx controller 1½ bit times before each new character is serialized out of the Tx shift register. (This is 2½ bits before the LSB of the new character appears on the TxD pin; there is an additional 1-bit delay in the transmitter data path due to the data encoding logic.)

### Tx Special Bit Pattern Transmission

The DUSCC provides features to transmit special bit patterns (see Table 14).

The TxD pin is held marking after a hardware reset, a reset Tx command, when the transmitter is not enabled, and during underrun/idle, if this feature is selected through TPR[7:5]. The TxD pin is also held marking if the transmitter is enabled, and the Tx FIFO is empty (ASYNC), or if a TSOM or TSOMP command has not been issued (SYNC modes).

The following command bits can be appended to characters in the Tx FIFO: TEOM, TDLE, exclude from CRC, and reset Tx CRC. An invoked command(s) is appended to the next character loaded into the Tx FIFO and follows the character through the FIFO until that character is ready to be loaded into the TxSR. The transmitter data path is shown in Figure 10. The following describes the operation of the transmitter for the various protocols.

### Tx ASYNC Mode

Serialization begins when the Tx FIFO data is loaded into the TxSR. The transmitter first sends a start bit, then the programmed number of bits/character (TPR[1,0]), a parity bit (if specified), and the programmed number of stop bits. Following the transmission of the

**Table 13. Abort Sequence — Protocol Mode**

TPRA [7:6]	PROTO-COL	LAST CHARACTER
00	BOP	FLAG following either FCS (if selected) or last data character
10	COP	Last byte of FCS before line begins SYN or MARKing
	BOP	Abort sequence (11111111) prior to MARKing
11	COP	Last byte of FCS before line begins SYN or MARKing
	BOP	Abort sequence (11111111) prior to FLAG
	COP	First SYN of SYN sequence

**Table 14. Special Bit Patterns**

PROTOCOL	BIT PATTERN
ASYNC-BREAK	An all 0's character including parity bit (if specified) and stop bits. Used for send break command.
COP-SYN	Contained in S1R (single SYN mode) or in S1R/S2R (dual SYN modes). Used for TSOM and TSOMP commands and for non-transparent mode linefill and IDLE.
COP-DLE	Used for TDLE command and for BISYNC transparent mode linefill and to generate BISYNC control sequences.
COP-CRC	16/8 bits from the CRC/LRC accumulator used for TEOM command or for auto-EOM modes.
BOP-FLAG	01111110. Used for TSOM, TSOMP, and TEOM commands, for auto-EOM modes, and as an IDLE line fill.
BOP-ABORT	11111111. Used for send ABORT command or during Tx FIFO underrun.
BOP-CRC	16 bits from the CRC accumulator used for TEOM command or for auto-EOM modes.
BOP/COP MARK	All 1's pattern on data line.

stop bits, if a new character is not available in the Tx FIFO, the TxD output goes to marking and the underrun condition (TRSR[7]) is set.

Transmission resumes when the CPU loads a new character into the Tx FIFO or issues a send break command. The send break command clears the Tx FIFO and forces a continuous space (low) on the TxD output after the character in TxSR (if any) is serialized. A send break acknowledge (TRSR[4]) is returned to the CPU to facilitate reassertion of the send break command in order to send an integral number of break characters. The send break condition is cleared when the reset Tx or disable Tx command is issued.

### Tx COP Modes

Transmitter commands associated with all COP modes are: transmit SOM (TSOM, transmit start of message), transmit SOM with PAD (TSOMP), transmit EO' (TEOM, transmit end of message), reset Tx CRC, exclude from CRC, and transmit DLE.

A TSOM or send TSOMP command must be issued to start COP transmission. TSOM (without PAD) causes the Tx CRC/LRC generator to be initialized and one or two SYN characters from S1R/S2R to be loaded into the TxSR and shifted out on the TxD output. A parity bit, if specified, is appended to each SYN character after the MSB. Send SOM acknowledge (TRSR[4]) is asserted when the SYN output begins. The user may reinvok

the command to cause multiple SYNs to be transmitted. If the command is not reinvoked and the Tx FIFO is empty, SYN patterns continue to be transmitted until the Tx FIFO is loaded. If data is present in the FIFO, the first character is loaded into the TxSR and serialization of the data begins. Note that the Tx FIFO may be preloaded with data before the TSOM is issued.

The TSOMP command causes all characters in the Tx FIFO (PAD characters) to be loaded into the TxSR and serialized if the Tx is enabled. Unlike the transmit SOM without PAD command, data (non-PAD characters) cannot be preloaded into the Tx FIFO. While the PAD is transmitted, parity is disabled and character length is automatically set to 8 bits regardless of the value in TPR[1:0]. When the Tx FIFO becomes empty after the PAD, the Tx CRC/LRC generator is initialized, the SYN character(s) are transmitted with optional parity appended, and send SOM acknowledge asserted. Operation then proceeds in the same manner as the TSOM command; the user has the option to invoke the TSOM command to cause multiple SYNs to be transmitted.

After the TSOM/TSOMP command is executed, characters in the Tx FIFO are loaded into the TxSR and shifted out with a parity bit, if specified, appended after the MSB. If, after the opening SYN(s) and at least one data has

## Dual Universal Serial Communications Controller (DUSCC) SCN68562

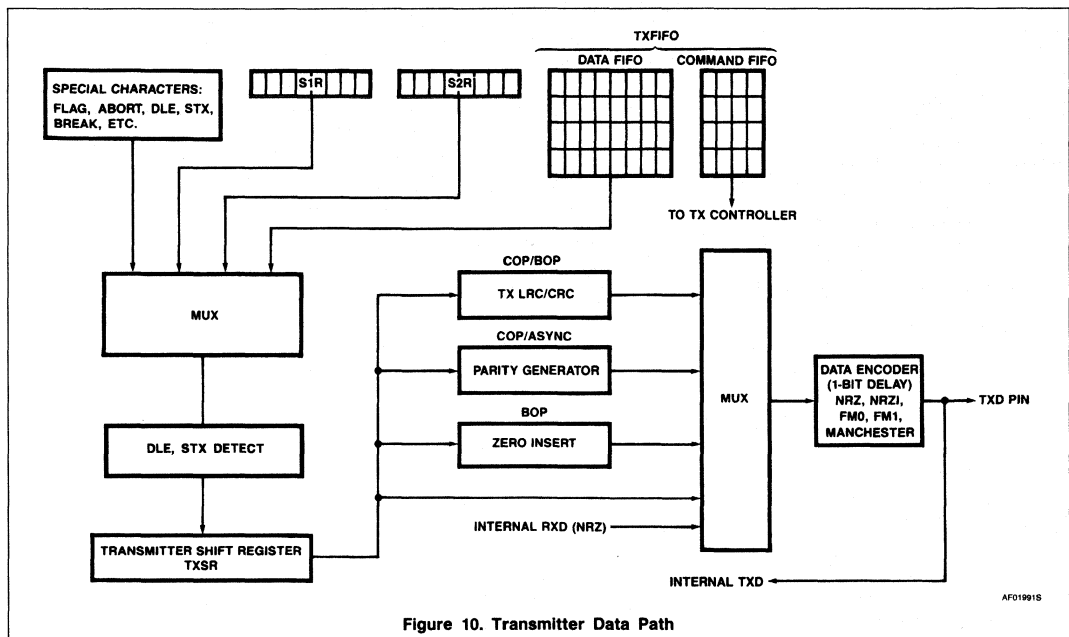

Figure 10. Transmitter Data Path

been transmitted, the TxFIFO is empty, a data underrun condition results and TRSR[7] is asserted. The transmitter's action on data underrun is determined by TPR[7:6] and the COP protocol. If TPR[7:6] = '10', the transmitter line fills with MARK characters until a character is loaded into the FIFO. If TPR[7:6] = '11' is selected, the transmitter line fills with SYN, SYN1-SYN2, or DLE-SYN1 for mono-sync, dual sync, and BISYNC transparent modes, respectively. If TPR[7:6] = '00', the BCC characters are transmitted and frame complete (TRSR[6]) is set. TxD then assumes the programmed idle state (TPR[5]) of MARKs or SYN1/SYN1-SYN2.

Operation resumes with the transmission of a SYN sequence when a TSOM command is invoked. A TSOMP command is ignored unless the transmitter is disabled and then reenabled.

An appended TEOM command also terminates the frame as described above. It occurs after transmission of the character to which the TEOM is appended. The TEOM command can be explicitly asserted through the channel command register. If TPR[4] = '1', the TEOM is automatically appended to a character in DMA mode, if the DONEN input is asserted when that character is loaded into the TxFIFO, or if the counter/timer is counting transmitted characters when the character

which causes the counter to reach zero count is loaded.

The TDLE command when appended to a character in the TxFIFO, causes the DLE character to be loaded into the TxSR and serialized before the TxFIFO character is loaded into the TxSR and serialized. This feature is particularly useful for BISYNC operation. The DLE character will be excluded from the CRC accumulation in BISYNC transparent mode (see below), but will be included in all other COP modes.

In BISYNC mode, transmission of a DLE-STx character sequence (either via a send TDLE command appended to the STx character, or via DLE and STx loaded into the TxFIFO) puts the transmitter into the transparent text mode of operation. In this mode, normally restricted character sequences can be transmitted as 'normal' bit sequences. The switch occurs after transmission of the two characters, so that the DLE and STx are included in the BCC accumulation. If the DLE-STx is to be excluded from the CRC, the user should issue a 'reset CRC' command prior to loading the next character.

Another method of excluding the two characters from the CRC is to invoke the 'exclude from CRC' command prior to loading the character(s) into the FIFO. While in transparent mode, the transmitter line fills with DLE-SYN1 and automatically transmits an extra

DLE if it finds a DLE in the TxFIFO ('DLE stuffing'). The transmitter reverts to non-transparent mode when the frame complete status is set in TRSR[5].

CRC/LRC accumulation can be specified in all COP modes; the type of CRC is specified via CMR2[2:0]. The TSOM/TSOMP commands set the CRC/LRC accumulator to its initial state and accumulation begins with the first non-SYN character after the initial SYN(s) are transmitted. PAD characters are not subject to CRC accumulation. In non-BISYNC or BISYNC normal modes, all transmitted characters except linefill characters (SYNs or MARKs) are subject to accumulation. In BISYNC transparent mode, odd (stuffed) DLEs and the DLE-SYN1 linefill are excluded from the accumulation. Characters can be selectively excluded from the accumulation by invoking the 'exclude from CRC' command prior to loading the character into the FIFO.

Accumulation stops when transmission of the first character of the BCC begins. The CPU can set the accumulator to its initial state prior to the transmission of any character by using the appended reset CRC command. The CRC generator is also automatically initialized after the EOM is sent.

#### TxBOP Modes

Transmitter commands associated with BOP modes are TSOM, TSOMP, TEOM, and trans-

# Dual Universal Serial Communications Controller (DUSCC) SCN68562

2

mit ABORT (TABRK). The TSOM and TSOMP commands are identical to COP modes except that a FLAG character (01111110) is used as the start of message sequence instead of the SYNS, and FLAG(s) that continue to be sent until the Tx FIFO is loaded. There is no zero insertion (see below) during transmission of the PAD characters, and they are not preceded by a FLAG or accumulated in the CRC. Character length is automatically set to 8 bits regardless of TPR[1:0].

The first characters loaded into the TxSR from the Tx FIFO are the address and control fields, which have fixed character lengths of eight bits. The number of address field bytes is determined by CMR1[4:3]. If extended address field is specified, the field is terminated if the first address octet is 'H'00' or if the LSB of the octet is a 1. The number of control field bytes is selected by CMR1\_5. If any information field characters follow the control field (forming an I field), they are transmitted with the number of bits per character programmed in TPR[1:0]. The TEOM command can be appended to the last character either explicitly or automatically as described for COP mode. When the character with the appended TEOM is loaded from the Tx FIFO, it is transmitted with the character length specified by OMR[7:5]. In this way, a residual character of 1–8 bits is transmitted without requiring the CPU to change the Tx character length for this last character.

After the opening FLAG and first address octet have been transmitted, an underrun occurs (TRSR[7] = 1) if the Tx FIFO is empty when the transmitter requires a new character. The underrun control bits (TPR[7:6]) determine whether the transmitter line fills with either ABORT-MARKS, ABORT-FLAGS (see below), or ends transmission with the 'normal' end of message sequence.

EOM on underrun is functionally similar to EOM due to an appended TEOM command. If the EOM is due to underrun, the normal character length applies to the last data character. After the last character is transmitted, the FCS (inverted CRC) and closing FLAG are sent, frame complete (TRSR[5]) is set, and the Tx CRC is initialized. If the Tx FIFO is empty after the closing FLAG has been sent, Tx D will assume the programmed idle state of FLAGS or MARKS (TPR[5]) and wait for a character to be loaded into the FIFO or for a TSOM command to be issued. If the Tx FIFO is not empty at that time, the Tx FIFO data will be loaded into the TxSR and serialized. In that case, the closing FLAG is the opening FLAG of the next frame.

The user can control the number of FLAGS between frames by invoking the TSOM command after frame complete is asserted. The

DUSCC then operates in the same manner as for transmission of multiple FLAGS at the beginning of a frame. When the command is no longer reinvoked, transmission of the Tx FIFO data will begin. If the FIFO is empty, FLAGS continue to be transmitted.

The DUSCC provides automatic zero insertion in the data stream to prevent erroneous transmission of the FLAG sequence. All data characters loaded into the TxSR from the Tx FIFO and characters transmitted from the CRC generator are subject to zero insertion. For this feature a zero is inserted in the serial data stream each time five consecutive ones (regardless of character boundaries) have been transmitted.

A send ABORT command clears the Tx FIFO and inserts an ABORT character of eight ones (not subject to zero insertion) into the TxSR for transmission after the current character has been serialized. A send abort ack (TRSR[4]) facilitates reassertion of send abort by the user to guarantee transmission of multiple abort characters. This feature can be used to send the 15-ones idle sequence. The transmitter sends either marks or FLAGS after the abort character(s) has been transmitted, depending on TPR[7:6]. Operation resumes with the transmission of a FLAG when a TSOM command is invoked. A TSOMP command is ignored unless the transmitter is disabled and then reenabled.

CRC accumulation can be specified in all BOP modes. The type of CRC is specified via CMR2[2:0], and is normally selected as CRC-CCITT preset to ones, although any option is valid. Note that LRC8 option is not allowed in BOP modes.

The TSOM/TSOMP command sets the CRC accumulator to its initial state and accumulation begins with the first address octet after the initial FLAG(s). Accumulation stops when transmission of the first character of the FCS begins. The CPU can set the accumulator to its initial state prior to the transmission of any character by using the appended reset CRC command and can exclude any character from the accumulation by use of the exclude from CRC command, but these features would not normally be used in BOP modes. The CRC generator is also automatically initialized after the EOM or an ABORT are sent.

### TxBOP Loop Mode

The loop modes are used by secondary stations on the loop, while the primary station operates in the BOP primary mode. Both the transmitter and receiver must be enabled. Loop operation is initiated by issuing the 'go on-loop' command. The receiver looks for the receipt of seven contiguous ones and then asserts the LC\_N output to cause external loop control hardware to put the DUSCC into

the loop, with the Tx D output echoing the Rx D input with a 2-bit time delay. The echoing process continues until a go active on poll (GAP) command is invoked. The DUSCC then looks for receipt of an EOP bit pattern (a zero followed by seven ones, 11111110) and changes the last one of the EOP into a zero making it an opening FLAG. Loop sending (TRSR[6]) is asserted at that same time. The action of the transmitter after sending the initial FLAG depends on the status of the transmit FIFO.

If the transmit FIFO is not empty, a normal frame transmission begins. The operation is then similar to normal BOP operation with the following differences:

1. An ABORT command, an underrun, or receipt of the turnaround sequence ('H'00') or a FLAG cause the transmitter to cease operation and to revert to echoing the Rx D input with a 2-bit time delay. A new transmission cannot begin until the GAP command is reinvoked and a new EOP sequence is received.
2. Subsequent to sending the EOM sequence of FCS-FLAG, the DUSCC examines the internal GAP flip-flop. If it is not set (having been reset by the 'reset GAP' command), the DUSCC reverts to echoing the received data. If the internal GAP flip-flop is still set, transmission of a new frame begins, with the user having control of sending multiple FLAGS between frames by use of the 'send SOM' command. If the FIFO is empty at this time, the DUSCC continues to send FLAGS until the data is loaded into the FIFO or until GAP is reset. If the latter occurs, it reverts to echoing Rx D.

When the DUSCC reverts to echoing Rx D in any of the above cases, the last transmitted zero and seven ones will form an EOP for the next station down the loop.

If the Tx FIFO is empty when the EOP is recognized, the transmitter continues to send FLAGS until there is data in the FIFO. If a turnaround sequence or the reset GAP command is received before the FIFO is loaded, the transmitter switches to echoing Rx D without any data transmission. Otherwise a frame transmission begins as above when a character is loaded into the FIFO. The mechanism provides time for the CPU to examine the received frame (the frame preceding the EOP) to determine if it should respond or not, while holding its option to initiate a transmission.

Termination of operation in the loop mode should be accomplished by use of the 'go off-loop' command. When the

# Dual Universal Serial Communications Controller (DUSCC) SCN68562

command is invoked, the DUSCC looks for the receipt of eight contiguous ones. It then negates the LC\_N output to cause the external loop control hardware to remove the DUSCC from the loop without affecting operation of other units remaining on the loop.

## RECEIVER

The receiver data path includes two 9-bit holding registers, HSRH and HSRL, an 8-bit character comparison register, CCSR, two synchronizing flip flops, a receiver shift register, RxSR, the programmable SYN comparison registers, S1R and S2R, and BISYNC character comparison logic. The DUSCC configures this circuitry and utilizes it according to the operational mode selected for the channel through the two mode registers CMR1 and CMR2. For all data paths, character data is assembled according to the character bit count, in the RxSR, and is moved to the RxFIFO with any appended statuses when assembly is completed. Figure 1 depicts the four data paths created in the DUSCC for the previous protocols.

### Receiver RxFIFO, RxRDY

The receiver converts received serial data on RxD (LSB first) into parallel data according to the transmission format programmed. Data is shifted through a synchronizing flip flop and one or more shift registers, the last of which is the 8-bit receiver shift register (RxSR). Bits are shifted into the RxSR on the rising edge of each  $1 \times$  receive clock until the LSB is in RxSR[0]. Hence, the received character is right justified, with all unused bits in the RxSR cleared to zero. A receive character length counter generates a character boundary signal for synchronization of character assembly, character comparisons, break detection (ASYNCR), and RxSR to RxFIFO transfers (except for BOP residual characters). During COP and BOP hunt phases, the SYN/FLAG comparison is made each receive bit time, as abort, and idle comparisons in BOP modes.

An internal clock from the BRG, the DPLL or the counter/timer, or an external  $1 \times$  or  $16 \times$  clock may be used as the receiver clock in ASYNCR mode. The BRG or counter/timer cannot be used directly for the receiver clock in synchronous modes, since these modes require a  $1 \times$  receive clock that is in phase with the received data. This clock may come externally from the RTxC or TRxC pins, or it may be derived internally from the DPLL. Encoded data is internally converted to NRZ format for the receiver circuits by using clock pulses generated by the DPLL.

When a complete character has been assembled in the RxSR, it is loaded into the receive FIFO with appended status bits. The most significant data bits of the character are set to

zero if the character length is less than eight bits. In ASYNCR and COP modes the user may select, via RPR[3], whether the data transferred to the FIFO includes the received parity bit or not. The receiver indicates to the CPU or DMA controller that it has data in the FIFO by asserting the channel's RxRDY status bit (GSR[4] or GSR[0]) and, if in DMA mode, the corresponding receiver DMA request pin.

The RxFIFO consists of four 8-bit holding registers with appended status bits for character count complete indications (all modes), character compare indication (ASYNCR), EOM indication (BISYNCR/BOP), and parity, framing, and CRC errors. Data is loaded into the RxFIFO from the RxSR and extracted (read) by the CPU or DMA controller via the data bus. An RxFIFO read creates an empty RxFIFO position for new data from the RxSR.

RxRDY assertion depends on the state of OMR[3]:

1. If OMR[3] is 0 (FIFO not empty), RxRDY is asserted each time a character is transferred from the receive shift register to the receive FIFO. If it is not reset by the CPU, RxRDY remains asserted until the receive FIFO becomes empty, at which time it is automatically negated. If it is reset by the CPU, it will remain negated, regardless of the current state of the receive FIFO, until a new character is transferred from the RxSR to the RxFIFO.
2. If OMR[3] is 1 (FIFO full), RxRDY is asserted:
  - a. when a character transfer from the receive shift register to the receive FIFO causes it to become full
  - b. when a character with a tagged EOM status bit is loaded into the FIFO (BISYNCR or BOP) regardless of RxFIFO full condition.
  - c. when the counter/timer is programmed to count received characters and the character which causes it to reach zero count is loaded into the FIFO (ICTSR[6]).
  - d. when the beginning of a break is detected in ASYNCR mode regardless of the RxFIFO full condition.

If it is not reset by the CPU, RxRDY remains asserted until the FIFO becomes empty, at which time it is automatically negated. If it is reset by the CPU, it will remain negated regardless of the current state of the receive FIFO, until it is asserted again due to one of the above conditions.

The assertion of RxRDY causes an interrupt to be generated if IER[4] and the channel's master interrupt enable (ICR[0] or ICR[1]) are asserted.

When DMA operation is programmed, the RxRDY status bit is routed to the DMA control circuitry for use as the channel receiver DMA request. Assertion of RxRDY results in assertion of RTxDRQN output.

Several status bits are appended to each character in the RxFIFO. When the FIFO is read, causing it to be 'popped', the status bits associated with the new character at the top of the RxFIFO are logically ORed into the RSR. Therefore, the user should read RSR before reading the RxFIFO in response to RxRDY activation. If character-by-character status is desired, the RSR should be read and cleared each time a new character is received. The user may elect to accumulate status over several characters or over a frame by clearing RSR at appropriate times. This mode would normally also be used when operating in DMA mode. If the RxFIFO is empty when a read is attempted, and wait mode as specified in CMR2[5:3], is not being used, a 'H'FF' is output on the data bus.

In all modes, the DUSCC protects the contents of the FIFO and the RxSR from overrun. If a character is received while the FIFO is full and a character is already in the RxSR waiting to be transferred into the FIFO, the overrun character is discarded and the OVERRUN status bit (RSR[5]) is asserted. If the overrun character is an end-of-message character, the character is lost but the FIFOed EOM status bit will be asserted when the character in the RxSR is loaded into the FIFO.

Operation of the receiver is controlled by the enable receiver command. When this command is issued, the DUSCC goes into the search for start bit state (ASYNCR), search for SYN state (COP modes), or search for FLAG state (BOP modes). When the disable receiver command is issued, the receiver ceases operation immediately. The RxFIFO is cleared on master reset, or by a reset receiver command. However, disabling the receiver does not affect the RxFIFO, RxRDY, or DMA request operation.

### Receiver DCD and RTS Controls

If DCD enable Rx, RPR[2], is asserted, the DCD input must be asserted for the receiver to operate. If RPR[2] is asserted and the sampling circuit detects that the DCD input has been negated, the receiver ceases operation immediately. Operation resumes when the sampled DCD is asserted again. A change of state detector is provided on the DCD input of each channel. The required duration of the DCD level change is described in the discussion of ICTSR[5]. The user may program a change of state to cause an interrupt to be generated (master interrupt enable ICR[0] or [1] and IER[7] must be set) so that appropriate action can be taken.

# Dual Universal Serial Communications Controller (DUSCC)      SCN68562

# 2

In ASYNC mode, RPR[4] can be programmed to control the deactivation of the RTS\_N output by the receiver. RTS\_N can be manually asserted and negated by writing to OMR[0]. However, the assertion of RPR[4] causes RTS to be negated automatically upon receipt of a valid start bit if the channel's receive FIFO is already full. When this occurs, the RTSN negated status bit, RSR[6], is set. This may be used as a flow control feature to prevent overrun in the receiver by using the RTS\_N output signal to control the CTS\_N input of the remote transmitter. The new character will be assembled in the RxSR, but its transfer to the FIFO will be delayed until the CPU reads the FIFO, making the FIFO position available for the new character.

Once enabled, receiver operation depends on channel protocol mode. The following describes the receiver operation for the various protocols:

## RxASYNC Mode

When first enabled, the receiver goes into the search for start bit state, looking for a high-to-low (mark-to-space) transition of the start bit on the RxD input. If a transition is detected, the state of the RxD pin is sampled again each  $16 \times$  clock for  $7\frac{1}{2}$  clocks ( $16 \times$  clock mode) or at the next rising edge of the bit time clock ( $1 \times$  clock mode). If RxD is sampled high, the start bit is invalid and the search for a valid start bit begins again.

If RxD is still low, a valid start bit is assumed and the receiver continues to sample the input at one bit time intervals (16 periods of the  $16 \times$  Rx clock; one period of the  $1 \times$  Rx clock) at the theoretical center of the bit, until the proper number of data bits and the parity bit (if specified) have been assembled, and the first stop bit has been detected.

The assembled character is then transferred to the RxFIFO with appended parity error (if parity is specified) and framing error status bits. The DUSCC can be programmed to compare this character to the contents of S1R. The appended character compare status bit, RSR[7], is set if the data matches and there is no parity error.

After the stop bit is sampled, the receiver will immediately look for the next start bit. However, if a non-zero character was received without a stop bit (i.e. framing error) and RxD remains low for one-half of the bit period after the stop bit was sampled, then the receiver operates as if a new start bit transition had been detected at that point (one-half bit time after the stop bit was sampled).

If a break condition is detected (RxD low for entire character time including optional parity and first stop bit), only one character consisting of all zeros will be loaded into the RxFIFO and break start detect, RSR[2], will be set.

The RxD input must return to a high condition for at least one half of a bit time ( $16 \times$  clock mode) or for one bit time ( $1 \times$  clock mode) before the break condition is terminated and the search for the next start bit begins. At that time, the break end detect condition, RSR[3], is set.

## Rx COP Modes

When the receiver is enabled in COP modes, it first goes into the SYN hunt phase, testing the received data each bit time for receipt of the appropriate SYN bit pattern, plus parity if specified, to establish character boundaries. Receipt of the SYN bit pattern terminates hunt phase and places the receiver in the data phase, in which all leading SYNs are stripped and the RxFIFO begins to load starting with the first non-SYN character. In COP single SYN protocol mode, S1R contains the SYN character required to establish character synchronization. In COP dual SYN and BISYNC protocol modes, S1R and S2R contain the first and second SYN characters, respectively, required to establish character synchronization. The SYN character length is the same as the character length programmed in RPR[1:0], plus the parity bit if parity is specified. SYN characters received with a parity error, when parity is specified, are considered invalid and will not cause synchronization to be achieved.

If external synchronization is programmed (RPR[4] = 1), the internal SYN detection and special character recognition logic are disabled and receipt of SYN characters is not required. A pulse on the SYNI input pin will establish character synchronization and terminate hunt phase. The SYNI pin is ignored after the first input on the SYNIN pin is received. The receiver must be disabled and then reenabled to resynchronize or to return to normal mode. This must be programmed in conjunction with CMR1[2:0] = 110. Refer to the description of RPR[4] for further details.

The SYN detect status bit, RSR[2], is set whenever SYN1, SYN1-SYN2, or DLE-SYN1 is detected for single SYN, dual SYN/BISYNC normal, and BISYNC transparent modes, respectively, and the SYNOUT pin will go active for one receive clock period one bit time after SYN detection in HSRH/HSRL. After character sync has been attained, the receiver enters the data phase and assembles characters in the RxSR, beginning with the first non-SYN character, with the least significant bit received first. It computes the BCC if specified, checks parity if specified, and checks for overrun errors.

The operation of the BCC (CRC/LRC) logic depends on the particular COP mode in use. The BCC is initialized upon first entering the data phase. For non-BISYNC modes, all received characters after entering data phase

are included in the BCC computation, except for leading SYNs and SYNs which are specified to be stripped by RPR[7]. As each received character is transferred from the RxSR to the FIFO, the current value of the BCC characters is checked and the CRC ERROR status bit (RSR[1]) is set if the value of the CRC remainder is not the expected value. The EOM status bit, RSR[7], is not set since there is no defined end-of-message character. The receiver computes the BCC for text messages automatically when operating in BISYNC protocol mode.

## BISYNC Features

The DUSCC provides support for both BISYNC normal and transparent operations. The following summarizes the features provided. Both EBCDIC and ASCII text messages can be handled by the DUSCC as selected by CMR1[5]. The receiver has the capability of recognizing special characters for the BISYNC protocol mode (see Table 15).

All sequences in Table 15, except SOH and STx, when detected explicitly cause a status to be affected. The following describes the conditions when this occurs.

The first character received when entering data phase for a header or text message should be an SOH, an STx, or a DLE-STx two-character sequence. Receipt of any of these initializes the CRC generator and starts the CRC accumulation. The SOH places the receiver in header mode, receipt of the STx places it in text mode, and receipt of the DLE-STx sequence (at any time) automatically places the receiver in transparent mode and sets the XPNT mode status bit, TRSR[0]. There is no explicit status associated with SOH and STx. If any other characters are received when entering the data phase, the message is treated as a control message and will not be accumulated in CRC.

After the data phase is established, the receiver searches the data stream for an end of message control character(s):

Header field: ENQ, ETB, or ITB

Normal text field: ENQ, ETx, ETB, or ITB

Transparent text field: DLE-ENQ, DLE-ETx, DLE-ETB, or DLE-ITB

Control message field: EOT, NAK, ACK0, ACK1, WACK, RVI or TTD

Detection of any one of these sequences causes the EOM status bit, RSR[7], to be set. Also if RPR[5] is set and the receiver does not detect a closing PAD (four 1's) after the 'EOT' or 'NAK', the PAD error status bit, RSR[6], is set. When the abort sequence ENQ or DLE-ENQ is detected, the character is tagged with an EOM status and transferred to the FIFO, but the appended CRC error

# Dual Universal Serial Communications Controller (DUSCC) SCN68562

status bit should be ignored. For the other EOM control sequences, the receiver waits for the next two bytes (the CRC bytes) to be received, checks the value of the CRC generator, and tags the transferred character with a CRC error, RSR[1], if the CRC remainder is not correct. See Figure 11 for an example of BCC accumulation in various BISYNC messages.

The CRC bytes are normally not transferred to the FIFO, unless the transfer FCS to FIFO control bit, RPR[6], is asserted. In this case the EOM and CRC error status bits will be tagged onto the last byte of the last FCS byte instead of to the last character of the message. After detecting one of the end-of-message (EOM) character sequences and setting RSR[7], the receiver automatically goes into auto hunt mode for the SYNC characters and PAD check if RRP[5] is set.

### SYNC Pattern Stripping

Leading SYNCs (before a message) are always stripped and excluded from the FCS, but SYNC patterns within a message are treated by the

receiver according to the RPR[7] bit. SYNC character patterns are defined for the various COP modes as follows:

COP single SYNC mode — SYNC1

COP dual SYNC mode — SYNC1, and SYNC2 when immediately preceded by SYNC1.

BISYNC normal mode — SYNC1, and SYNC2 when immediately preceded by SYNC1. SYNC1 is always stripped, even if it is not followed by SYNC2 when stripping is selected.

BISYNC transparent mode — DLE - SYNC1, where the DLE is the last of an odd number of consecutive DLEs.

0 Strip only RPR[7] leading the SYNC and do not accumulate in FCS.

1 Strip all SYNCs. Additionally, strip odd DLEs when operating in BISYNC transparent mode. Do not accumulate stripped characters in FCS.

Processing of the SYNC patterns is determined by the RPR[7] bit, the COP mode, and the

position of the pattern in the frame. This is summarized in Table 16.

The value of the RPR[7] field does not affect the setting of the SYNC DETECT status bit, RSR[2], and the generation of a SYNCOUT pulse when a SYNC pattern is received.

### RxBOP Mode

In BOP protocol mode, the receiver may be in any one of four phases: hunt phase, address field (A) phase, control field (C) phase, or information field (I) phase. The character length for the A and C phases is always 8 bits. The I field character length is specified in RPR[1:0].

**DESIGN NOTE:** If the residual character length is not zero, the unused most significant bits in the receiver FIFO are not necessarily zero. The unused bits should be ignored, this will not cause a CRC error.

After an enable receiver command is executed, the receiver enters hunt phase, in which a comparison for the string (01111110) is done every Rx bit time. The FLAG delineates the beginning (and end) of a received frame and establishes the character boundary. Each FLAG match in CCSR causes the FLAG detect status bit (RSR[2]) to be set and SYNCOUT N pin to be activated one bit time later for one receive clock period. FLAGS with an overlapping zero will be detected. All FLAGS are deleted from the data stream.

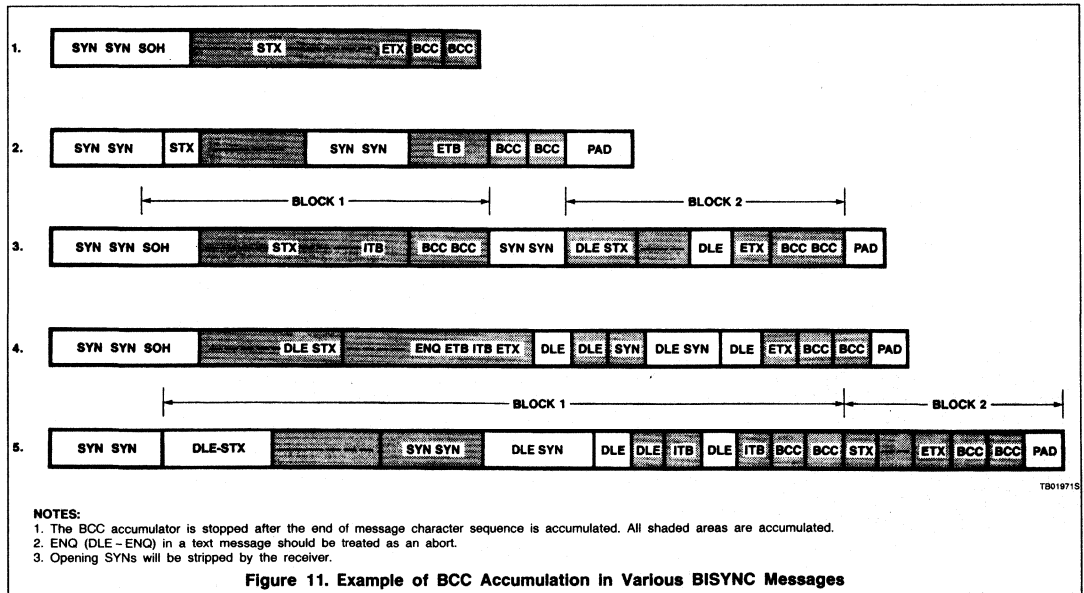

## Dual Universal Serial Communications Controller (DUSCC) SCN68562

Table 15. BISYNC Features

BISYNC — Single-Character Sequences			
Sequence	ASCII	EBCDIC	Description
SOH	H'01	H'01	Start of header
STx	H'02	H'02	Start of text
ETx	H'83	H'03	End of text
EOT	H'04	H'37	End of transmission
ENQ	H'85	H'2D	Enquiry
DLE	H'10	H'10	Data link escape
NAK	H'15	H'3D	Negative ack
ETB	H'97	H'26	End of transmission block
ITB	H'1F	H'1F	End of intermediate transmission block
BISYNC — Two-Character Sequences			
Sequence	ASCII	EBCDIC	Description
ACK0	H'10,B0	H'10,70	Acknowledge 0
ACK1	H'10,31	H'10,61	Acknowledge 1
WACK	H'10,38	H'10,6B	Wait before transmit positive ack
RVI	H'10,BC	H'10,7C	Reverse interrupt
TTD	H'02,85	H'02,2D	Temporary text delay
BISYNC — (Transparent Text Mode) — Two-Character Sequences			
Sequence	ASCII	EBCDIC	Description
DLE-ENQ	H'10,85	H'10,2D	Enquiry
DLE-ITB	H'10,1F	H'10,1F	End of intermediate transmission block
DLE-ETB	H'10,97	H'10,26	End of transmission block
DLE-ETx	H'10,83	H'10,03	End of text
DLE-STx	H'10,02	H'10,02	Start of transparent text mode

Table 16. SYN Pattern Processing

MODE	RPR [7]	LEADING SYNs	WITHIN A MESSAGE
BISYNC	0	no FCS no FIFO	no FCS Pattern into FIFO
	1	no FCS no FIFO	no FCS no FIFO
COP	0	no FCS no FIFO	Accumulate in FCS Pattern into FIFO
	1	no FCS no FIFO	no FCS no FIFO

Once a FLAG has been detected, the receiver will exit hunt phase and enter address phase. The handling of the address field is determined by the values programmed in CMR1[2:0], which selects one of the BOP modes. The BOP secondary address modes are selected by CMR1 [4:3] and function as in the description that follows.

**Single-Octet Address**

For receive, the address comparison for a secondary station is made on the first octet

following the opening FLAG. A match occurs if the first octet after the FLAG matches the contents of S1R, or if all parties address (RPR[3]) is asserted and the first octet is equal to H'FF'.

**Dual-Octet Address**

For receive, the address comparison for a secondary station is made on the first two octets following the opening FLAG.

A match occurs if the first two octets after the FLAG match the contents of S1R and S2R respectively, or if all parties address (RPR[3]) is asserted and the first two octets are equal to H'FF, FF'.

**Dual Address with Group Mode**

For receive, the address comparison for a secondary station is made on the first two octets following the opening FLAG. A match occurs for one of three possible conditions. If the first two octets after the FLAG match the contents of S1R and S2R, respectively, or if the first octet is H'FF' and the second matches the contents of S2R (group mode), or when all parties address (RPR[3]) is asserted and the first two octets are equal to H'FF, FF'. The second condition (group mode) allows a selected group of stations to receive a message.

**Extended Address Mode**

Extend address field to the next octet if the LSB of the current address octet is zero. Address field is terminated if the LSB of the address is a one. The address field will be terminated after the first octet if the null address H'00' is received/transmitted as the first address octet. For this mode the receiver does not perform an address comparison (all received characters after the opening FLAG are transferred to the FIFO) but does determine when the address field is terminated.

The length of the A field may be a single octet, a dual octet, or more octets, as described above. A primary station or an extended address secondary station does not perform an address comparison, and all characters in the A, C, and I fields after the flag are transferred to the FIFO. Although address field comparisons are not performed, the length of the address field is still determined by CMR1[4:3]. For the other secondary address modes, if there is a match, or the received character(s) match either of the other enabling conditions (group or all-parties address), all characters in the A, C, and I fields are transferred to the FIFO. If there is no match, the receiver returns to the FLAG hunt phase.

C phase begins after A phase is terminated. The receiver receives one or two control characters, CMR1[5]. After this phase is terminated, the character length is switched automatically from 8 bits to the number of bits specified in RPR[1:0] and the information field phase is entered.

The frame is terminated when a closing FLAG is detected. The same FLAG can also serve as the opening FLAG of the next frame. The 16 bits received prior to the closing FLAG form the frame check sequence (if an FCS is specified in CMR2[2:0]). All non-FLAG characters of the frame are accumulated in the CRC checker and the result is compared to the expected remainder. Failure to match will cause a CRC error. EOM detect RSR[7], RCL not zero RSR[0], and CRC error RSR[1] are normally FIFOed with the last character of the I field. RCL not zero RSR[0] is set if the length of the last character of the I field does not have the length programmed in RPR[1:0]. The residual character length in TRSR[2:0] is also valid at that time. The CRC characters themselves are normally not passed to the Rx FIFO. However, if the transfer FCS to FIFO control bit RPR[6] is asserted, the FCS bytes will be transferred to the FIFO. In this case the EOM, CRC error, and RCL not zero status bits will be tagged onto the last byte of the CRC sequence instead of to the last character of the message.

If the closing FLAG is received prior to receipt of the appropriate number of A field, C field

## Dual Universal Serial Communications Controller (DUSCC)

SCN68562

as programmed in CMR1[5:3], and FCS field octets, a short frame will be detected and RSR[4] will be set. The I field need not be present in a valid frame. An abort (11111110) comparison is done after an opening FLAG has been received and up to receipt of the closing FLAG. A match causes the abort detect status bit (RSR[6]) to be set. The receiver then enters FLAG search mode. The abort is stripped from the received data stream.

If a zero followed by 15 contiguous ones is detected, the idle detect status bit RSR[3] is set. This comparison is done whenever the receiver is enabled. Therefore, it can occur before or after a received frame.

Zero deletion is performed during BOP receive. A zero after 5 contiguous ones is deleted from the data stream regardless of character boundaries. Deleted zeroes are not subject to CRC accumulation. FLAG, ABORT, and IDLE comparisons are done prior to zero deletion.

If external synchronization is programmed (RPR[4] = 1), the internal FLAG detection and address comparison logic is disabled and receipt of FLAGs is not required. In this arrangement, a pulse on the SYNI-N input pin will establish synchronization and terminate hunt phase. The receiver will then go immediately into the I-field mode with zero deletion disabled, assembling and transferring characters into the FIFO with the character length specified in RPR[1:0]. The SYNI-N pin is ignored after the first input on the SYNI-N pin is received. The receiver must be disabled and then reenabled to resynchronize or to return to normal operating mode.

This mode must be programmed in conjunction with CMR1[2:0] = 110. Refer to the description of RPR[4] for further details.

**BOP Loop Mode**

Operation of the receiver in BOP loop protocol mode is similar to operation in other BOP modes, except that only certain frame formats are supported. Several character detection functions that interact with the operation

of the transmitter or transmitter commands are added:

1. When the 'go on-loop' command is invoked, the receiver looks for the receipt of a zero followed by seven ones and then asserts the LC\_N output.
2. When the 'go off-loop' command is invoked, the receiver looks for the receipt of eight contiguous ones and then negates the LC\_N output.
3. The TxD output normally echoes the receive input with a two bit time delay. When the 'go active on poll' command is asserted, the receiver looks for an EOP (a zero followed by seven ones) and then switches the TxD output line to the normal transmitter output. Receipt of an EOP or an ABORT sets RSR[6].
4. Receipt of a turnaround sequence (eight contiguous zeros) terminates the transmitter operation, if any, and returns the TxD output to echoing the RxD input. RSR[3] is set if a turnaround is received.

See transmitter operation for additional details.

**SUMMARY OF COP FEATURES**

<b>COP Dual SYN Mode</b>	
SYN detect	SYN1-SYN2
Linefill	SYN1-SYN2
SYN stripping	SYN1-SYN2 used to establish character sync, i.e. leading SYNs. Subsequent to this (after receiving first non-SYN character), SYN1 and SYN1-SYN2 if stripping is specified by RPR[7].
Excluded from FCS**	SYN1 and SYN1-SYN2 before beginning of message, i.e. leading SYNs and, if SYN stripping is specified by RPR[7] anywhere else in the message for the Rx; linefill SYN1-SYN2 for Tx regardless of RPR[7]. (If SYN stripping is not specified, then SYNs within a message will be included in FCS by Rx.)
<b>BISYNC normal mode</b>	
SYN detect	SYN1-SYN2
Linefill	SYN1-SYN2
SYN stripping	SYN1-SYN2 used to establish character sync, i.e. leading SYNs. Subsequent to this (after receiving first non-SYN character), SYN1 and SYN1-SYN2 if stripping is specified by RPR[7].
Excluded from FCS	All SYNs either before or within a message, regardless of RPR[7], plus additional characters as required by the protocol.
<b>BISYNC transparent mode</b>	
SYN detect	*DLE-SYN1
Linefill	DLE-SYN1
SYN/DLE stripping	*DLE-SYN1 and odd DLEs if stripping is specified by RPR[7].
Excluded from FCS	*DLE-SYN1 and odd DLEs, regardless of RPR[7] plus additional characters as required by the protocol.
<b>COP single SYN mode</b>	
SYN detect	SYN1
Linefill	SYN1
SYN stripping	SYN1 used to establish character sync, i.e. leading SYNs. Subsequent to this, SYN1 if stripping is specified by RPR[7].
Excluded from FCS**	SYN1 before beginning of message, i.e. leading SYNs, and if SYN stripping is specified by RPR[7], anywhere else in the message for the Rx; linefill SYN1 for Tx regardless of RPR[7]. (If SYN stripping is not specified, then SYNs within a message will be included in FCS by Rx.)

**NOTES:**

\*DLE indicates last DLE of an odd number of consecutive DLEs.

\*\*In non-BISYNC COP modes (single or dual SYN case), if SYN stripping is off, i.e. RPR[7] = 0, then SYNs within a message will be included in FCS by receiver. Therefore, the remote DUSCC transmitter should be careful not to let the TxFIFO overrun since the linefill SYN characters are not accumulated in FCS by the transmitter regardless of RPR[7]. Letting the TxFIFO overrun will result in a CRC error in the receiver.



## Dual Universal Serial Communications Controller (DUSCC)

SCN68562

2

ABSOLUTE MAXIMUM RATINGS<sup>1</sup>

SYMBOL	PARAMETER	RATING	UNIT
T <sub>A</sub>	Operating ambient temperature <sup>2</sup> range	0 to +70	°C
T <sub>STG</sub>	Storage temperature range	-55 to +150	°C
	All voltages with respect to ground <sup>3</sup>	-0.5 to +6.0	V

DC ELECTRICAL CHARACTERISTICS T<sub>A</sub> = 0°C to +70°C, V<sub>CC</sub> = 5.0V ± 5%<sup>4, 5, 6</sup>

SYMBOL	PARAMETER	TEST CONDITIONS	LIMITS			UNIT
			Min	Typ	Max	
V <sub>IL</sub>	Input low voltage All except X1/CLK X1/CLK				0.8 .04	V V
V <sub>IH</sub>	Input high voltage All except X1/CLK X1/CLK		2 2.4			V V
V <sub>OL</sub>	Output low voltage except DONEN, IRQN DONEN, IRQN	I <sub>OL</sub> = 2.4mA I <sub>OL</sub> = 8.8mA			0.5 0.5	V V
V <sub>OH</sub>	Output high voltage (except o.c. outputs)	I <sub>OH</sub> = -400μA	2.4			V
I <sub>X1L</sub>	X1/CLK low input current	V <sub>IN</sub> = 0, X2 grounded V <sub>IN</sub> = 0, X2 floated	-4.5 -4.5			mA mA
I <sub>X1H</sub>	X1/CLK high input current	V <sub>IN</sub> = V <sub>CC</sub> , X2 grounded V <sub>IN</sub> = V <sub>CC</sub> , X2 floated			1 30	mA mA
I <sub>X2L</sub>	X2 low input current	V <sub>IN</sub> = 0, X1/CLK floated	-100			μA
I <sub>X2H</sub>	X2 high input current	V <sub>IN</sub> = V <sub>CC</sub> , X1/CLK floated			100	μA
I <sub>IL</sub>	Input leakage current	V <sub>IN</sub> = 0 to V <sub>CC</sub>	-10		10	μA
I <sub>LL</sub>	Data bus 3-State leakage current	V <sub>0</sub> = 0 to V <sub>CC</sub>	-10		10	μA
I <sub>OC</sub>	Open-collector output leakage current	V <sub>0</sub> = 0 to V <sub>CC</sub>	-10		10	μA
I <sub>CC</sub>	Power supply current				200	mA

## NOTES:

- Stresses above those listed under Absolute Maximum Ratings may cause permanent damage to the device. This is a stress rating only and functional operation of the device at these or at any other conditions above those indicated in the operation section of this specification is not implied.
- For operating at elevated temperatures, the device must be derated based on +150°C maximum junction temperature and thermal resistance of 35°C/W junction to ambient for ceramic DIP, 35°C/W for plastic DIP, and 41°C/W for PLCC.
- This product includes circuitry specifically designed for the protection of its internal devices from damaging effects of excessive static charge. Nonetheless, it is suggested that conventional precautions be taken to avoid applying any voltages larger than the rated maxima.
- Parameters are valid over specified temperature range.
- All voltage measurements are referenced to ground (GND). For testing, all inputs except X1/CLK swing between 0.4V and 2.4V with a transition time of 20ns maximum. For X1/CLK, this swing is between 0.4V and 4.4V. All time measurements are referenced at input voltages of 0.8V and 2V and output voltages of 0.8V and 2.0V as appropriate.
- Typical values are at +25°C, typical supply voltages, and typical processing parameters.
- Test condition for outputs: C<sub>L</sub> = 150pF, except interrupt outputs. Test conditions for interrupt outputs: C<sub>L</sub> = 50pF, R<sub>L</sub> = 2.7kΩ to V<sub>CC</sub>.
- This specification will impose maximum 68000 CPU CLK to 6MHz. Higher CPU CLK can be used if repeating bus reads are not performed.
- Execution of the valid command (after it is latched) requires 3-4 falling edges of X1 (see Figure 14).
- Tests for open drain outputs are intended to guarantee switching of the output transistor. Measurement of this response is referenced from the midpoint of the switching signal to a point 0.5V above V<sub>OL</sub>. This point represents noise margin that assures true switching has occurred. Beyond this level, the effects of external circuitry and test environment are pronounced and can greatly affect the resultant measurement.

## Dual Universal Serial Communications Controller (DUSCC)

SCN68562

AC ELECTRICAL CHARACTERISTICS  $T_A = 0^\circ\text{C}$  to  $+70^\circ\text{C}$ ,  $V_{CC} = 5\text{V} \pm 5\%$ <sup>4, 5, 6, 7</sup>

NO.	FIGURE	PARAMETER	TENTATIVE LIMITS			UNIT
			Min	Typ	Max	
1	12	RESETN pulse width	3			$\mu\text{s}$
2	13, 15	A0 – A6 setup time to CSN low	10			ns
3	13, 15	A0 – A6 hold time from CSN high	0			ns
4	13, 15	RWN setup time to CSN low	0			ns
5	13, 15	RWN hold time to CSN high	0			ns
6	13, 15	CSN high pulse width <sup>9</sup>	160			ns
7	13, 15, 16	CSN or IACKN high from DTACKN low	30			ns
8	13, 16	Data valid from CSN low			300	ns
9	13	Data bus floating from CSN high			270	ns
10	15	Data hold time from CSN high <sup>9, 10, 11</sup>	0			ns
11	13, 16	DTACKN low from read data ready	0			ns
12	13, 15	DTACKN low from CSN low			480	ns
13	13, 15	DTACKN high from CSN high			235	ns
14	13, 15	DTACKN high impedance from CSN high			360	ns
15	16	DTACKN low from IACKN low			650	ns
16	17	Port input setup time to CSN low	20			ns
17	17	Port input hold time from CSN low	120			ns
18	17	Port output valid from DTACK low			560	ns
19	18	IRQN high from: <sup>12</sup> Read Rx FIFO (RxRDY interrupt) Write Tx FIFO (TxRDY interrupt) Write RSR (receiver condition interrupt) Write TRSR (receiver/transmitter interrupt) Write ICTSR (port change and timer/counter interrupt)			300 300 650 650 650	ns ns ns ns ns
20	19	X1/CLK high or low time X1/CLK frequency CTCLK high or low time CTCLK frequency RxC high or low time RxC frequency  TxC high or low time TxC frequency	25 2 100 0 110 0 0 110 0 0	14.7456	16 4 4 4 4	ns MHz ns MHz ns MHz ns MHz ns MHz
21	20	TxD output from 1X TxC input low			385	ns
22	20	TxD output from TxC output low	0		50	ns
23	21	RxD data setup time to RxC high	50			ns
24	21	RxD data hold time from RxC high	0			ns
25	22	IACKN low to daisy chain low			350	ns
26	24	Data valid from receive DMA ACKN			320	ns
27	23, 24	DTCN width	100			ns
28	23, 24	RDYN low to DTCN low	80			ns
29	24	Data bus float from DTCN low			300	ns
30	23, 24	DMA ACKN low to RDYN (DTACKN) low			600	ns
31	23, 24	RDYN high from DTCN low			420	ns
32	23, 24	RDYN high impedance from DTCN low			530	ns
33	24	Receive DMA REQN high from DMA ACKN low			585	ns
34	24	Receive DMA ACKN width	150			ns
35	23, 24	Receive DMA ACKN low to DONEN low			300	ns
36	23	Data setup to DTCN low	300			ns
37	23	Data hold from DTCN low	230			ns
38	23	Transmit DMA REQN high from ACKN low			550	ns
39	23	Transmit DMA ACKN deasserted width	150			ns
40	23	Transmit DMA ACKN low to DONEN low output			550	ns
41	25	CSN low to transmit DONEN low output			400	ns
42	25	CSN low to transmit DMA REQ negated			620	ns
43	25	CSN low to receive DONEN low			400	ns
44	25	CSN low to receive DMA REQ negated			620	ns

Dual Universal Serial Communications Controller (DUSCC)

SCN68562

2

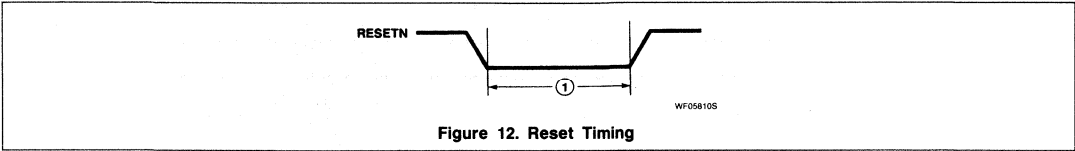

Figure 12. Reset Timing

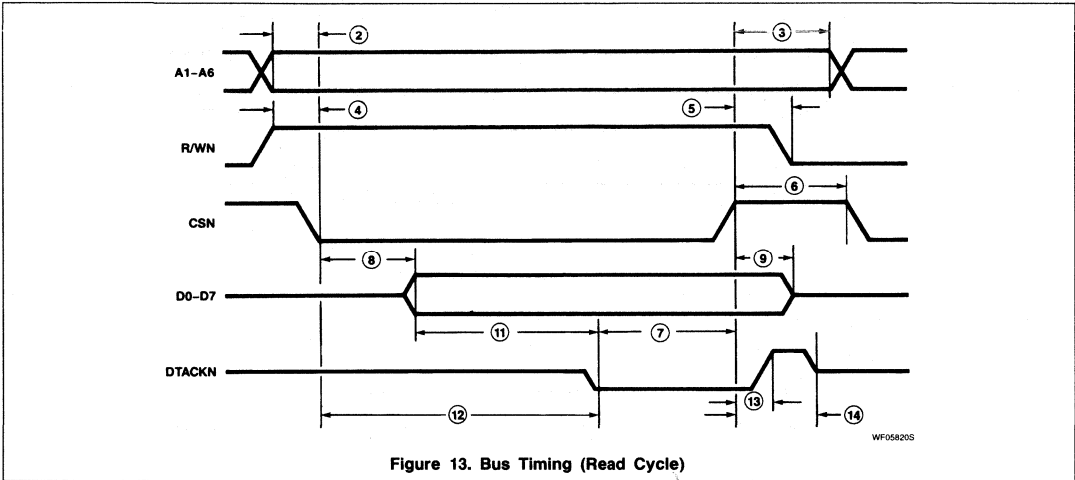

Figure 13. Bus Timing (Read Cycle)

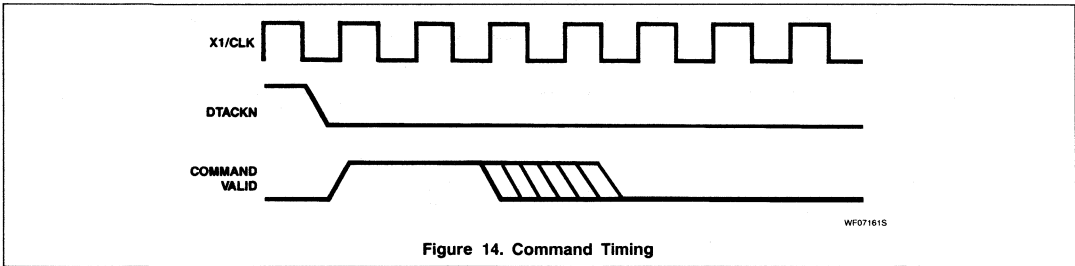

Figure 14. Command Timing

Dual Universal Serial Communications Controller (DUSCC)

SCN68562

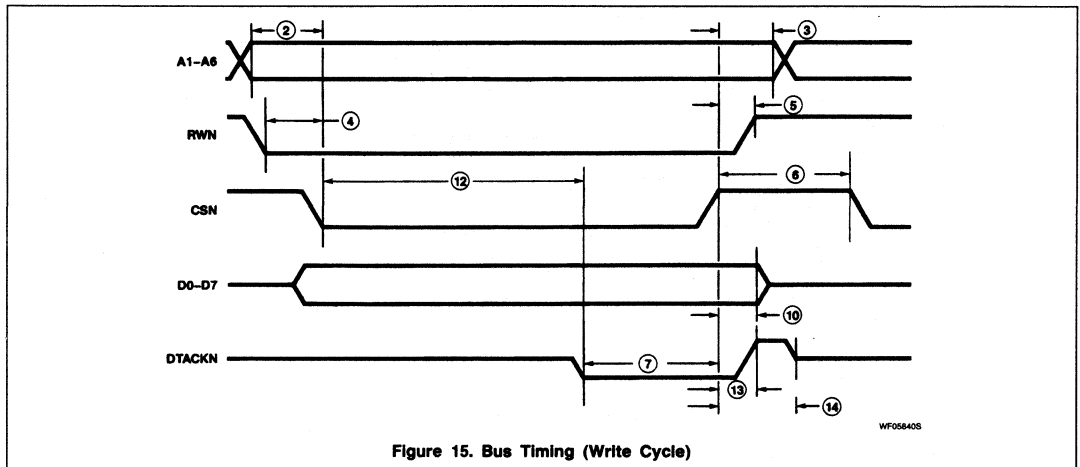

Figure 15. Bus Timing (Write Cycle)

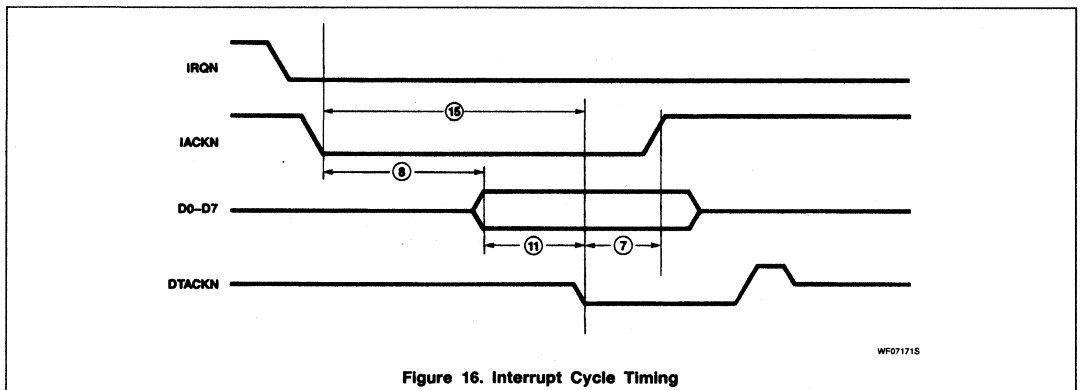

Figure 16. Interrupt Cycle Timing

Dual Universal Serial Communications Controller (DUSCC)

SCN68562

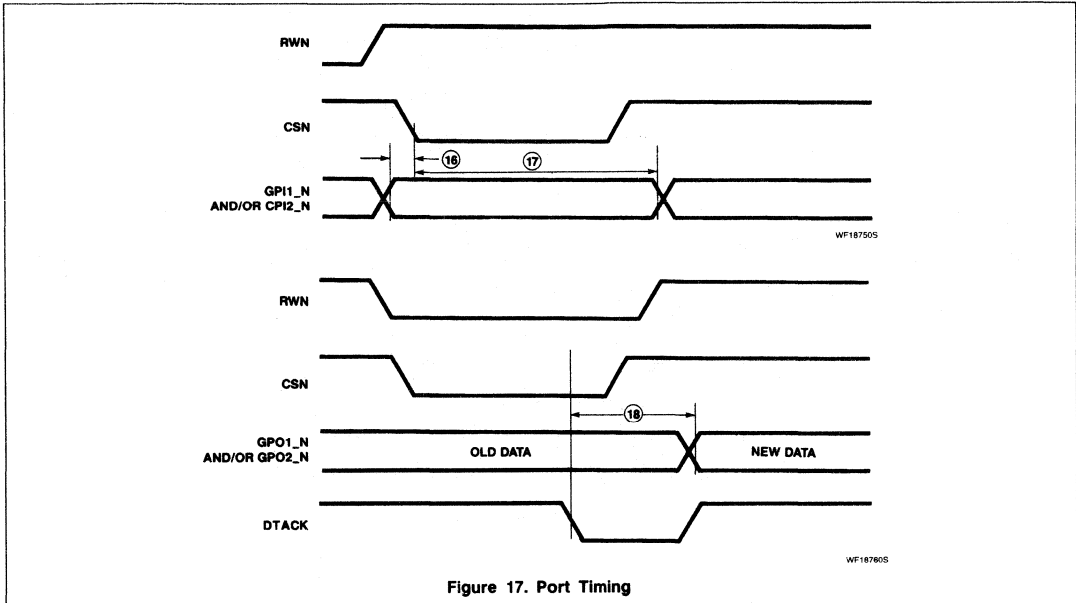

Figure 17. Port Timing

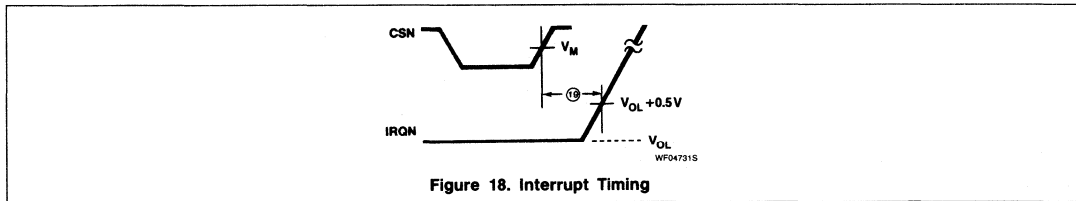

Figure 18. Interrupt Timing

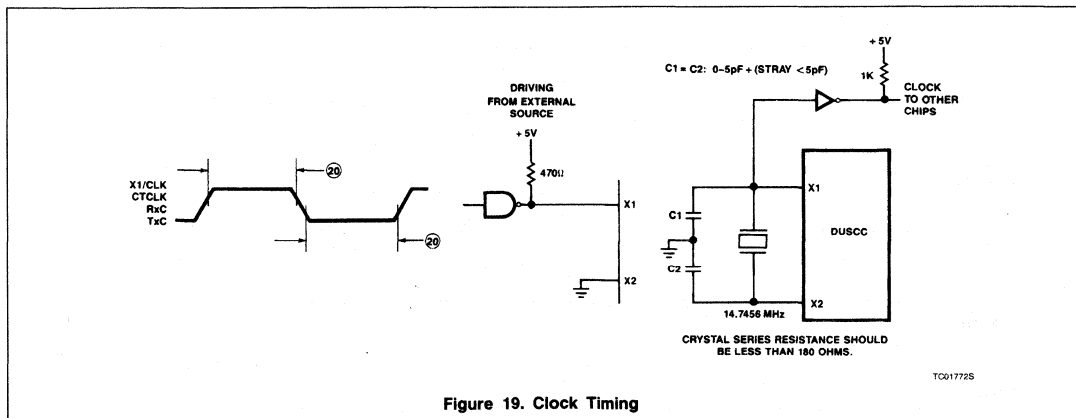

Figure 19. Clock Timing

# Dual Universal Serial Communications Controller (DUSCC)

SCN68562

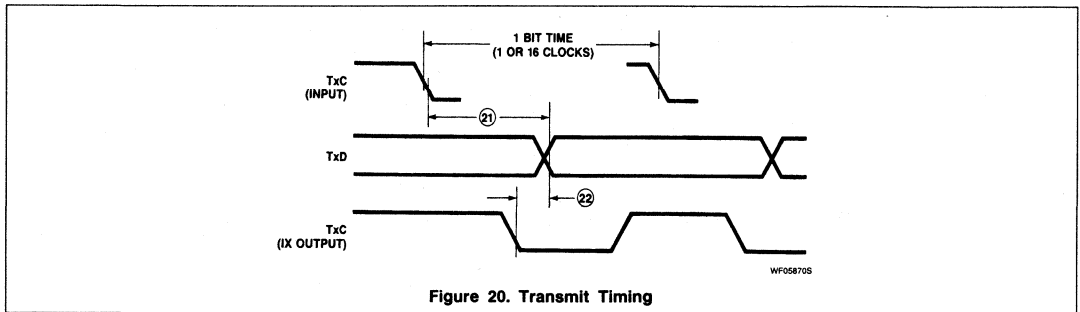

Figure 20. Transmit Timing

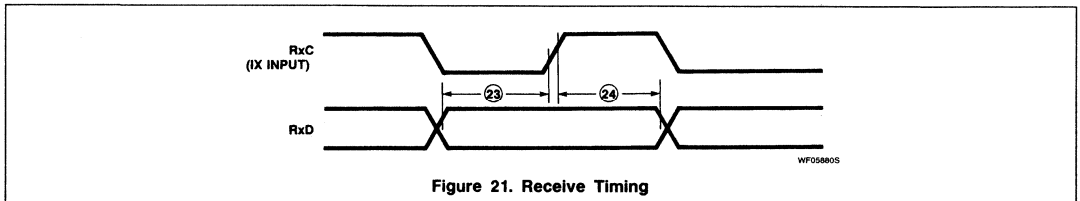

Figure 21. Receive Timing

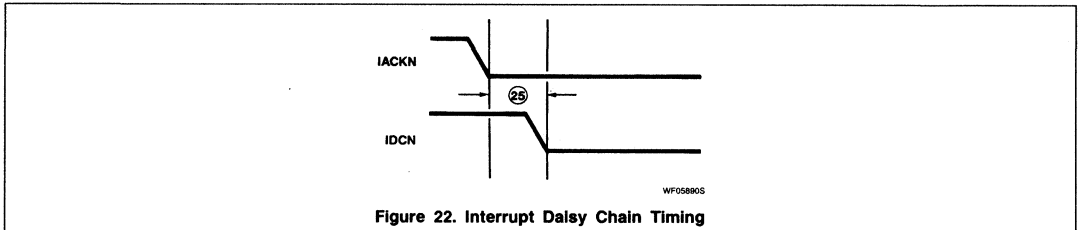

Figure 22. Interrupt Daisy Chain Timing

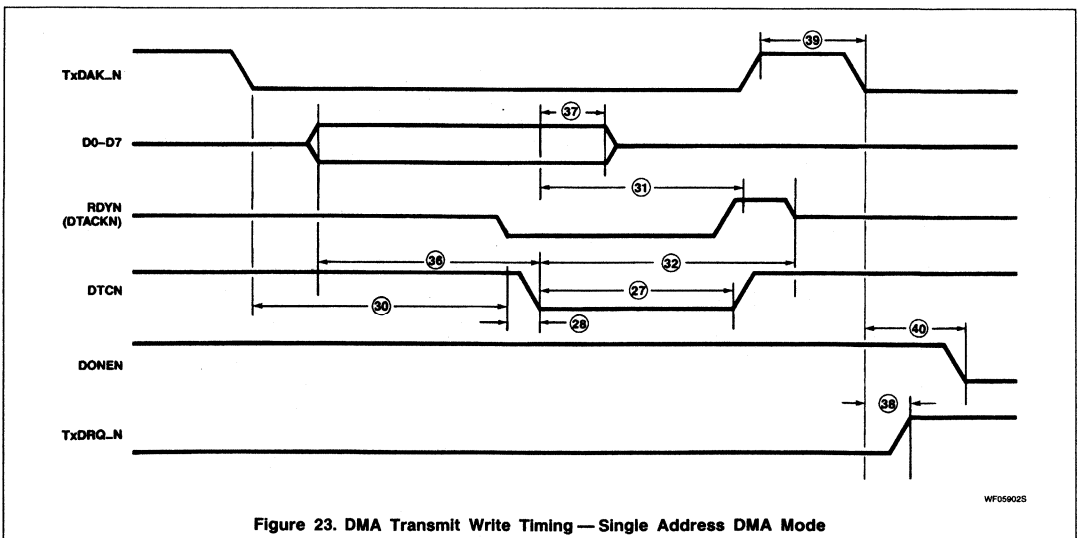

Figure 23. DMA Transmit Write Timing — Single Address DMA Mode

Dual Universal Serial Communications Controller (DUSCC)

SCN68562

2

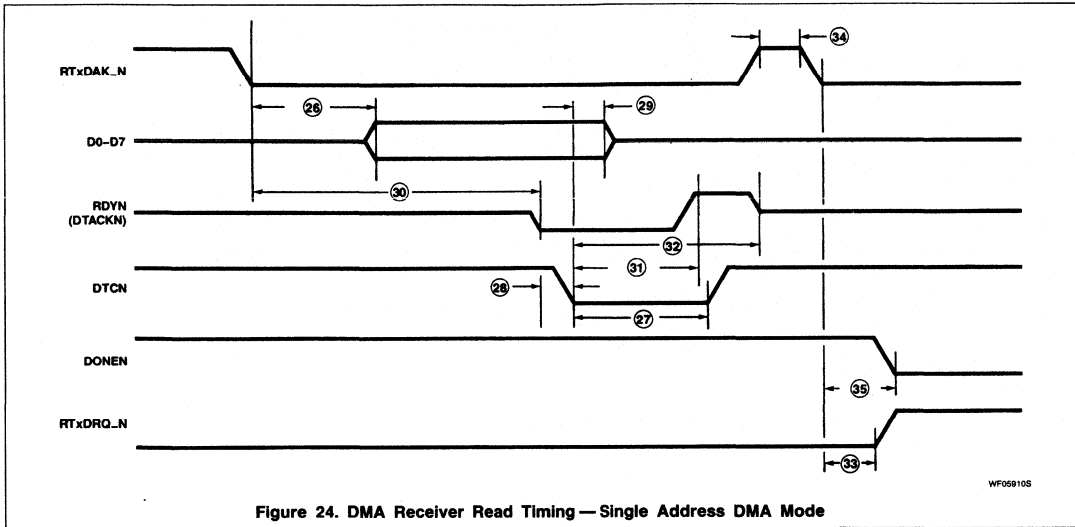

Figure 24. DMA Receiver Read Timing — Single Address DMA Mode

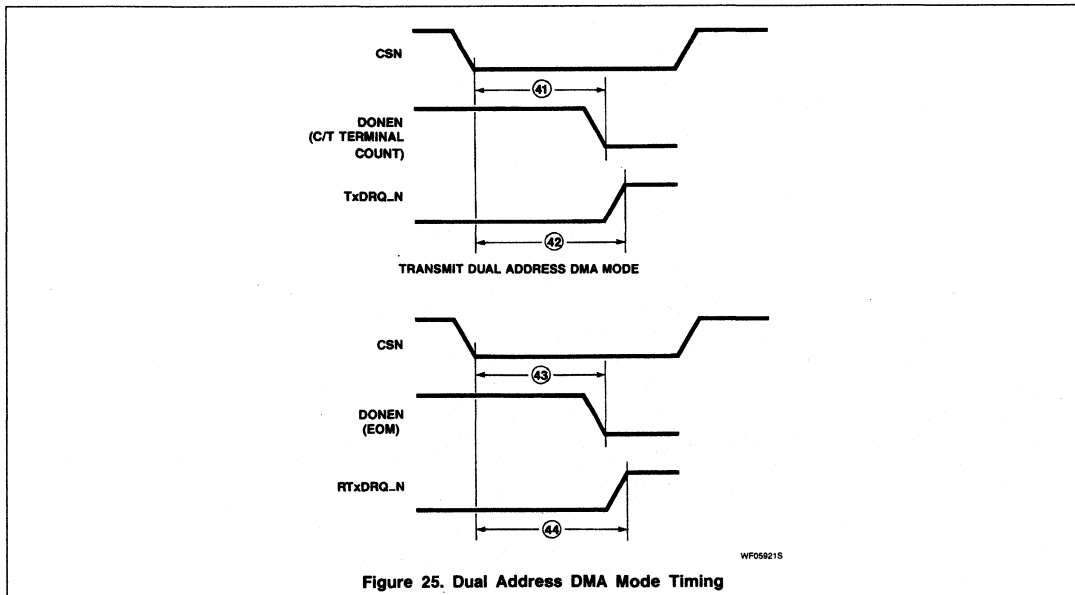

Figure 25. Dual Address DMA Mode Timing

# SCN68681

## Dual Asynchronous Receiver/ Transmitter (DUART)

### Product Specification

#### Microprocessor Products

#### DESCRIPTION

The Signetics SCN68681 Dual Universal Asynchronous Receiver/Transmitter (DUART) is a single-chip MOS-LSI communications device that provides two independent full-duplex asynchronous receiver/transmitter channels in a single package. It is compatible with other S68000 family devices, and can also interface easily with other microprocessors. The DUART can be used in polled or interrupt driven systems.

The operating mode and data format of each channel can be programmed independently. Additionally, each receiver and transmitter can select its operating speed as one of eighteen fixed baud rates, a  $16\times$  clock derived from a programmable counter/timer, or an external  $1\times$  or  $16\times$  clock. The baud rate generator and counter/timer can operate directly from a crystal or from external clock inputs. The ability to independently program the operating speed of the receiver and transmitter make the DUART particularly attractive for dual-speed channel applications such as clustered terminal systems.

#### FEATURES

- S68000 bus compatible
- Dual full-duplex asynchronous receiver/transmitter
- Quadruple buffered receiver data registers
- Programmable data format
  - 5 to 8 data bits plus parity
  - Odd, even, no parity or force parity
  - 1, 1.5 or 2 stop bits programmable in  $\frac{1}{16}$ -bit increments
- Programmable baud rate for each receiver and transmitter selectable from:
  - 18 fixed rates: 50 to 38.4k baud

- One user-defined rate derived from programmable timer/counter
- External  $1\times$  or  $16\times$  clock
- Parity, framing, and overrun error detection
- False start bit detection
- Line break detection and generation
- Programmable channel mode
  - Normal (full-duplex)
  - Automatic echo
  - Local loopback
  - Remote loopback
- Multi-function programmable 16-bit counter/timer
- Multi-function 6-bit input port
  - Can serve as clock or control inputs
  - Change-of-state detection on four inputs
- Multi-function 8-bit output port
  - Individual bit set/reset capability
  - Outputs can be programmed to be status/interrupt signals
- Versatile interrupt system
  - Single interrupt output with eight maskable interrupting conditions
  - Interrupt vector output on interrupt acknowledge
  - Output port can be configured to provide a total of up to six separate wire-ORable interrupt outputs
- Maximum data transfer:  $1\times$  - 1MB/sec,  $16\times$  - 125kB/sec
- Automatic wake-up mode for multidrop applications
- Start-end break interrupt/status
- Detects break which originates in the middle of a character
- On-chip crystal oscillator
- TTL compatible
- Single +5V power supply

#### PIN CONFIGURATIONS

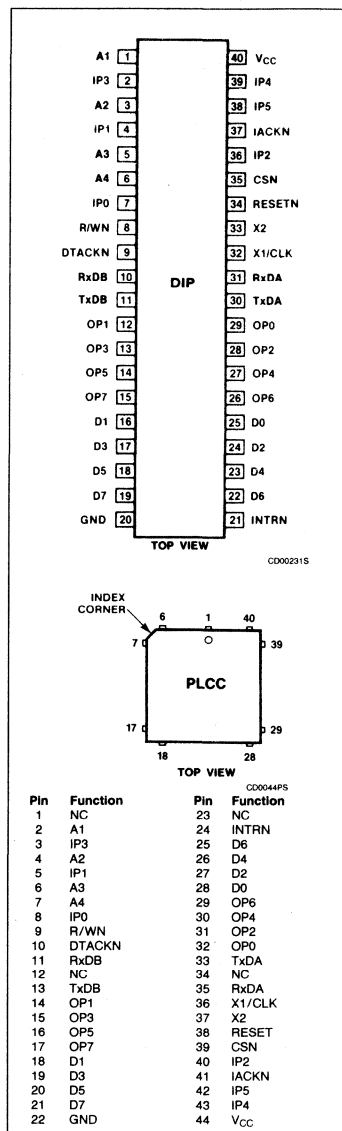



# Dual Asynchronous Receiver/Transmitter (DUART)

## SCN68681

2

### ORDERING INFORMATION

PACKAGES	V <sub>CC</sub> = +5V ±5%, T <sub>A</sub> = 0°C to +70°C
Ceramic DIP	SCN68681C1140
Plastic DIP	SCN68681C1N40
Plastic LCC	SCN68681CIA44

### BLOCK DIAGRAM

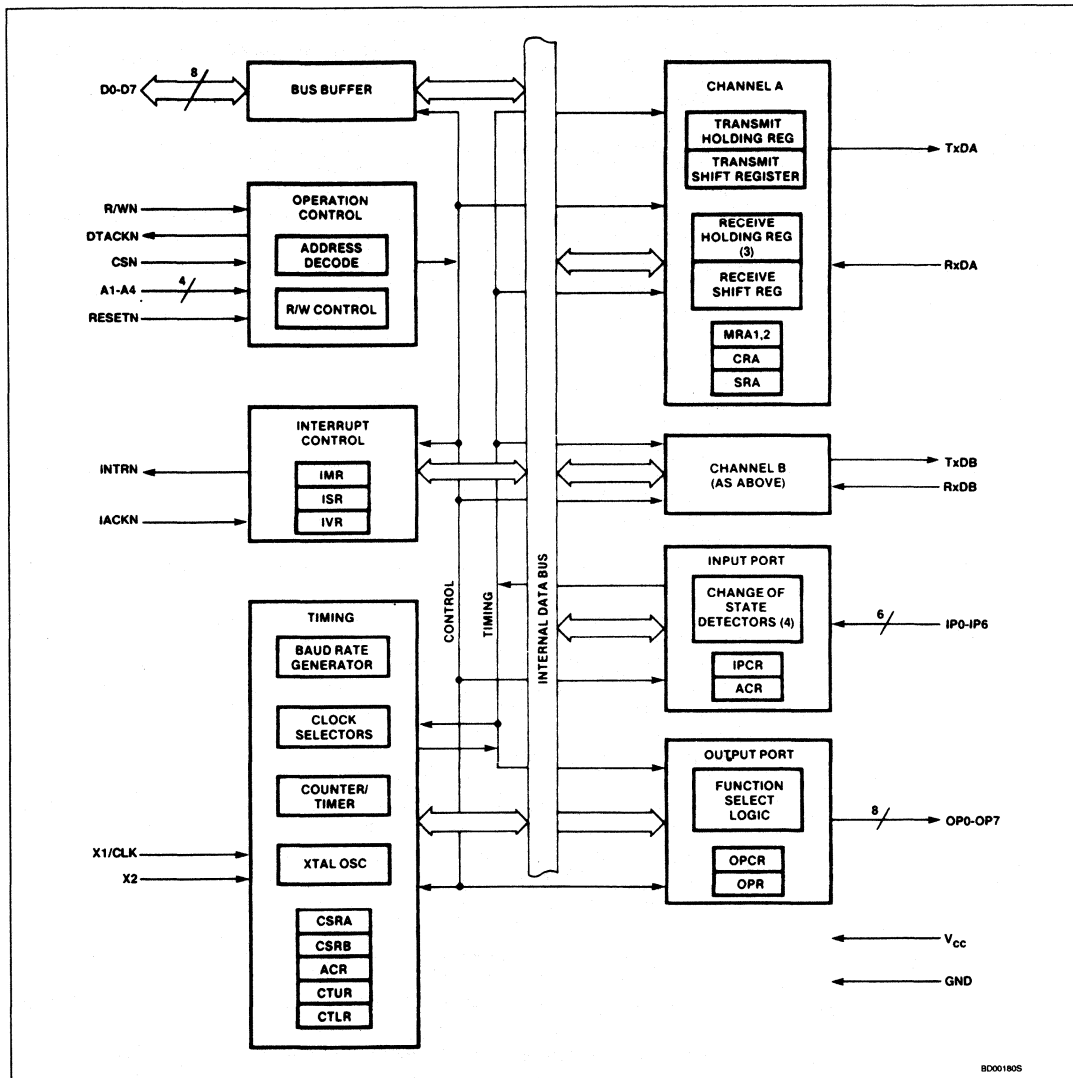

B0001805

## Dual Asynchronous Receiver/Transmitter (DUART)

SCN68681

## PIN DESCRIPTION

MNEMONIC	PIN NO.		TYPE	NAME AND FUNCTION
	DIP	PLCC		
D0 – D7	25, 16, 24 17, 23, 18 22, 19	28, 18, 27 19, 26, 20 25, 21	I/O	<b>Data Bus:</b> Bidirectional 3-State data bus used to transfer commands, data and status between the DUART and the CPU. D0 is the least significant bit.
CSN	35	39	I	<b>Chip Select:</b> Active low input signal. When low, data transfers between the CPU and the DUART are enabled on D0 – D7 as controlled by the R/WN and A1 – A4 inputs. When high, places the D0 – D7 lines in the 3-State condition.
R/WN	8	9	I	<b>Read/Write:</b> A high input indicates a read cycle and a low input indicates a write cycle, when a cycle is initiated by assertion of the CSN input.
A1 – A4	1, 2, 5, 6	2, 4, 6, 7	I	<b>Address Inputs:</b> Select the DUART internal registers and ports for read/write operations.
RESETN	34	38	I	<b>Reset:</b> A low clears internal registers (SRA, SRB, IMR, ISR, OPR, OPCR), initializes the IVR to hex 0F, puts OP0 – OP7 in the high state, stops the counter/timer, and puts channel A and B in the inactive state, with the TxDA and TxDB outputs in the mark (high) state.
DTACKN	9	10	O	<b>Data Transfer Acknowledge:</b> 3-State active low output asserted in write, read, or interrupt cycles to indicate proper transfer of data between the CPU and the DUART.
INTRN	21	24	O	<b>Interrupt Request:</b> Active low, open drain output which signals the CPU that one or more of the eight maskable interrupting conditions are true.
IACKN	37	41	I	<b>Interrupt Acknowledge:</b> Active low input indicating an interrupt acknowledge cycle. In response, the DUART will place the interrupt vector on the data bus and will assert DTACKN if it has an interrupt pending.
X1/CLK	32	36	I	<b>Crystal 1:</b> Crystal or external clock input. A crystal or clock of the specified limits must be supplied at all times. If a crystal is used, a capacitor must be connected from this pin to ground (see Figure 7).
X2	33	37	I	<b>Crystal 2:</b> Connection for other side of the crystal. If a crystal is used, a capacitor must be connected from this pin to ground (see Figure 7). If X1/CLK is driven from an external source, this pin should be grounded.
RxDA	31	35	I	<b>Channel A Receiver Serial Data Input:</b> The least significant bit is received first. 'Mark' is high, 'space' is low.
RxDB	10	11	I	<b>Channel B Receiver Serial Data Input:</b> The least significant bit is received first. 'Mark' is high, 'space' is low.
TxDA	30	33	O	<b>Channel A Transmitter Serial Data Output:</b> The least significant bit is transmitted first. This output is held in the 'mark' condition when the transmitter is disabled, idle, or when operating in local loopback mode. 'Mark' is high, 'space' is low.
TxDB	11	13	O	<b>Channel B Transmitter Serial Data Output:</b> The least significant bit is transmitted first. This output is held in the 'mark' condition when the transmitter is disabled, idle, or when operating in local loopback mode. 'Mark' is high, 'space' is low.
OP0	29	32	O	<b>Output 0:</b> General purpose output, or channel A request to send (RTSAN, active low); can be deactivated automatically on receive or transmit.
OP1	12	14	O	<b>Output 1:</b> General purpose output, or channel B request to send (RTSBN, active low); can be deactivated automatically on receive or transmit.
OP2	28	40	O	<b>Output 2:</b> General purpose output, or channel A transmitter 1× or 16× clock output, or channel A receiver 1× clock output.
OP3	13	15	O	<b>Output 3:</b> General purpose output, or open drain, active low counter/timer output, or channel B transmitter 1× clock output, or channel B receiver 1× clock output.
OP4	27	30	O	<b>Output 4:</b> General purpose output, or channel A open drain, active low, RxRDYA/FFULLA output.
OP5	14	16	O	<b>Output 5:</b> General purpose output or channel B open drain, active low, RxRDYB/FFULLB output.
OP6	26	29	O	<b>Output 6:</b> General purpose output, or channel A open drain, active low, TxRDYA output.
OP7	15	17	O	<b>Output 7:</b> General purpose output, or channel B open drains, active low, TxRDYB output.
IPO	7	8	I	<b>Input 0:</b> General purpose input, or channel A clear to send active low input (CTSAN).

## Dual Asynchronous Receiver/Transmitter (DUART)

SCN68681

## PIN DESCRIPTION (Continued)

MNEMONIC	PIN NO.		TYPE	NAME AND FUNCTION
	DIP	PLCC		
IP1	4	5	I	<b>Input 1:</b> General purpose input, or channel B clear to send active low input (CTSBN).
IP2	36	40	I	<b>Input 2:</b> General purpose input, or channel B receiver external clock input (RxCB), or counter/timer external clock input. When the external clock is used by the receiver, the received data is sampled on the rising edge of the clock.
IP3	2	3	I	<b>Input 3:</b> General purpose input, or channel A transmitter external clock input (TxCA). When the external clock is used by the transmitter, the transmitted data is clocked on the falling edge of the clock.
IP4	39	43	I	<b>Input 4:</b> General purpose input, or channel A receiver external clock input (RxCA). When the external clock is used by the receiver, the received data is sampled on the rising edge of the clock.
IP5	38	42	I	<b>Input 5:</b> General purpose input, or channel B transmitter external clock input (TxCB). When the external clock is used by the transmitter, the transmitted data is clocked on the falling edge of the clock.
V <sub>CC</sub>	40	44	I	<b>Power Supply:</b> +5V supply input.
GND	20	22	I	<b>Ground</b>

Each receiver is quadruply buffered to minimize the potential of receiver overrun or to reduce interrupt overhead in interrupt driven systems. In addition, a flow control capability is provided to disable a remote DUART transmitter when the buffer of the receiving device is full.

Also provided on the SCN68681 are a multipurpose 6-bit input port and a multipurpose 8-bit output port. These can be used as general purpose I/O ports or can be assigned specific functions (such as clock inputs or status/interrupt outputs) under program control.

### BLOCK DIAGRAM

The SCN68681 DUART consists of the following eight major sections: data bus buffer, operation control, interrupt control, timing, communications channels A and B, input port and output port. Refer to the block diagram.

#### Data Bus Buffer

The data bus buffer provides the interface between the external and internal data buses. It is controlled by the operation control block to allow read and write operations to take place between the controlling CPU and the DUART.

#### Operation Control

The operation control logic receives operation commands from the CPU and generates appropriate signals to internal sections to control device operation. It contains address decoding and read and write circuits to permit communications with the microprocessor via the data bus buffer. The DTACKN output is asserted during write and read cycles to indicate to the CPU that data has been

latched on a write cycle, or that valid data is present on the bus on a read cycle.

#### Interrupt Control

A single active low interrupt output (INTRN) is provided which is activated upon the occurrence of any of eight internal events. Associated with the interrupt system are the interrupt mask register (IMR), the interrupt status register (SR), the auxiliary control register (ACR), and the interrupt vector register (IVR). The IMR may be programmed to select only certain conditions to cause INTRN to be asserted. The ISR can be read by the CPU to determine all currently active interrupting conditions. When IACKN is asserted, and the DUART has an interrupt pending, the DUART responds by placing the contents of the IVR register on the data bus and asserting DTACKN.

Outputs OP3–OP7 can be programmed to provide discrete interrupt outputs for the transmitters, receivers, and counter/timer.

#### Timing Circuits

The timing block consists of a crystal oscillator, a baud rate generator, a programmable 16-bit counter/timer, and four clock selectors. The crystal oscillator operates directly from a 3.6864MHz crystal connected across the X1/CLK and X2 inputs. If an external clock of the appropriate frequency is available, it may be connected to X1/CLK. The clock serves as the basic timing reference for the baud rate generator (BRG), the counter/timer and other internal circuits. A clock signal within the limits specified in the specifications section of this data sheet must always be supplied to the DUART. If an external signal is used instead of a crystal, X1 should be driven using a configuration similar to the one in Figure 7.

The baud rate generator operates from the oscillator or external clock input and is capable of generating 18 commonly used data communications baud rates ranging from 50 to 38.4k baud. The clock outputs from the BRG are at  $16\times$  the actual baud rate. The counter/timer can be used as a timer to produce a  $16\times$  clock for any other baud rate by counting down the crystal clock or an external clock. The four clock selectors allow the independent selection, for each receiver and transmitter, of any of these baud rates or an external timing signal.

The counter/timer (C/T) can be programmed to use one of several timing sources as its input. The output of the C/T is available to the clock selectors and can also be programmed to be output at OP3. In the counter mode, the contents of the C/T can be read by the CPU and it can be stopped and started under program control. In the timer mode, the C/T acts as a programmable divider.

#### Communications Channels

##### A and B

Each communications channel of the SCN68681 comprises a full-duplex asynchronous receiver/transmitter (DUART). The operating frequency for each receiver and transmitter can be selected independently from the baud rate generator, the counter timer, or from an external input.

The transmitter accepts parallel data from the CPU, converts it to a serial bit stream, inserts the appropriate start, stop, and optional parity bits and outputs a composite serial stream of data on the TxD output pin. The receiver accepts serial data on the RxD pin, converts this serial input to parallel format, checks for start bit, stop bit, parity bit (if any), or break

# Dual Asynchronous Receiver/Transmitter (DUART)

SCN68681

condition and sends an assembled character to the CPU.

## Input Port

The input port pulse detection circuitry uses a 38.4kHz sampling clock derived from one of the baud rate generator taps. This results in a sampling period of slightly more than 25 $\mu$ s (assuming that the clock input is 3.6864MHz). The detection circuitry, in order to guarantee a true change in level has occurred, requires that two successive samples at the new logic level be observed. As a consequence, the minimum duration of the signal change is 25 $\mu$ s if the transition occurs coincident with the first sample pulse. The 50 $\mu$ s time refers to the situation in which the change of state is just missed and the first change of state is not detected until 25 $\mu$ s later.

The inputs to this unatched 6-bit port can be read by the CPU by performing a read operation at address D16. A high input results in a logic 1 while a low input results in a logic 0. D7 will always be read as a logic 1 and D6 will reflect the level of IACKN. The pins of this port can also serve as auxiliary inputs to certain portions of the DUART logic.

Four change-of-state detectors are provided which are associated with inputs IP3, IP2, IP1, and IP0. A High-to-Low or Low-to-High transition of these inputs lasting longer than 25–50 $\mu$ s will set the corresponding bit in the input port change register. The bits are cleared when the register is read by the CPU. Any change of state can also be programmed to generate an interrupt to the CPU.

## Output Port

The 8-bit multi-purpose output port can be used as a general purpose output port, in which case the outputs are the complements of the output port register (OPR).  $OPR[n] = 1$  results in  $OP[n] = \text{low}$  and vice-versa. Bits of the OPR can be individually set and reset. A bit is set by performing a write operation at address E<sub>16</sub> with the accompanying data specifying the bits to be set (1 = set, 0 = no change). Likewise, a bit is reset by a write at address F16 with the accompanying data specifying the bits to be reset (1 = reset, 0 = no change).

Outputs can be also individually assigned specific functions by appropriate programming of the channel A mode registers (MR1A, MR2A), the channel B mode registers (MR1B, MR2B), and the output port configuration register (OPCR).

## OPERATION

### Transmitter

The SCN68681 is conditioned to transmit data when the transmitter is enabled through the command register. The SCN68681 indi-

cates to the CPU that it is ready to accept a character by setting the TxRDY bit in the status register. This condition can be programmed to generate an interrupt request at OP6 or OP7 and INTRN. When a character is loaded into the transmit holding register (THR), the above conditions are negated. Data is transferred from the holding register to the transmit shift register when it is idle or has completed transmission of the previous character. The TxRDY conditions are then asserted again which means one full character time of buffering is provided. Characters cannot be loaded into the THR while the transmitter is disabled.

The transmitter converts the parallel data from the CPU to a serial bit stream on the TxD output pin. It automatically sends a start bit followed by the programmed number of data bits, an optional parity bit, and the programmed number of stop bits. The least significant bit is sent first. Following the transmission of the stop bits, if a new character is not available in the THR, the TxD output remains high and the TxEMT bit in the status register (SR) will be set to 1. Transmission resumes and the TxEMT bit is cleared when the CPU loads a new character into the THR. If the transmitter is disabled, it continues operating until the character currently being transmitted is completely sent out. The transmitter can be forced to send a continuous low condition by issuing a send break command.

The transmitter can be reset through a software command. If it is reset, operation ceases immediately and the transmitter must be enabled through the command register before resuming operation. If CTS operation is enabled, the CTSN input must be low in order for the character to be transmitted, if it goes high in the middle of a transmission, the character in the shift register is transmitted and TxDA then remains in the marking state until CTSN goes low. The transmitter can also control the deactivation of the RTSN output. If programmed, the RTSN output will be reset one bit time after the character in the transmit shift register and transmit holding register (if any) are completely transmitted; only if the transmitter has been disabled.

### Receiver

The SCN68681 is conditioned to receive data when enabled through the command register. The receiver looks for a high to low (mark to space) transition of the start bit on the RxD input pin. If a transition is detected, the state of the RxD pin is sampled each 16 $\times$  clock for 7 $\frac{1}{2}$  clocks (16 $\times$  clock model) or at the next rising edge of the bit time clock (1 $\times$  clock model). If RxD is sampled high, the start bit is invalid and the search for a valid start bit begins again. If RxD is still low, a valid start bit is assumed and the receiver continues to sample the input at one bit time intervals at

the theoretical center of the bit, until the proper number of data bits and the parity bit (if any) have been assembled, and one stop bit has been detected. The least significant bit is received first. The data is then transferred to the receive holding register (RHR) and the RxRDY bit in the SR is set to a 1. This condition can be programmed to generate an interrupt at OP4 or OP5 and INTRN. If the character length is less than eight bits, the most significant unused bits in the RHR are set to zero.

After the stop bit is detected, the receiver will immediately look for the next start bit. However, if a non-zero character was received without a stop bit (framing error) and RxD remains low for one half of the bit period after the stop bit was sampled, then the receiver operates as if a new start bit transition had been detected at that point (one-half bit time after the stop bit was sampled).

The parity error, framing error, overrun error and received break state (if any) are strobed into the SR at the received character boundary, before the RxRDY status bit is set. If a break condition is detected (RxD is low for the entire character including the stop bit), a character consisting of all zeros will be loaded into the RHR and the received break bit in the SR is set to 1. The RxD input must return to a high condition for at least one-half bit time before a search for the next start bit begins.

The RHR consists of a first-in-first-out (FIFO) stack with a capacity of three characters. Data is loaded from the receive shift register into the topmost empty position of the FIFO. The RxRDY bit in the status register is set whenever one or more characters are available to be read, and a FFULL status bit is set if all three stack positions are filled with data. Either of these bits can be selected to cause an interrupt. A read of the RHR outputs the data at the top of the FIFO. After the read cycle, the data FIFO and its associated status bits (see below) are 'popped' thus emptying a FIFO position for new data.

In addition to the data word, three status bits (parity error, framing error, and received break) are also appended to each data character in the FIFO (overrun is not). Status can be provided in two ways, as programmed by the error mode control bit in the mode register. In the 'character' mode, status is provided on a character-by-character basis; the status applies only to the character at the top of the FIFO. In the 'block' mode, the status provided in the SR for these three bits is the logical-OR of the status for all characters coming to the top of the FIFO since the last 'reset error' command was issued. In either mode reading the SR does not affect the FIFO. The FIFO is 'popped' only when the

## Dual Asynchronous Receiver/Transmitter (DUART)

SCN68681

Table 1. 68681 Register Addressing

A4	A3	A2	A1	READ (R/WN = 1)	WRITE (R/WN = 0)
0	0	0	0	Mode Register A (MR1A, MR2A)	Mode Register A (MR1A, MR2A)
0	0	0	1	Status Register A (SRA)	Clock Select Reg. A (CSRA)
0	0	1	0	*Reserved*	Command Register A (CRA)
0	0	1	1	Rx Holding Register A (RHRA)	Tx Holding Register A (THRA)
0	1	0	0	Input Port Change Reg. (IPCR)	Aux. Control Register (ACR)
0	1	0	1	Interrupt Status Reg. (ISR)	Interrupt Mask Reg. (IMR)
0	1	1	0	Counter/Timer Upper (CTU)	C/T Upper Register (CTUR)
0	1	1	1	Counter/Timer Lower (CTL)	C/T Lower Register (CTLR)
1	0	0	0	Mode Register B (MR1B, MR2B)	Mode Register B (MR1B, MR2B)
1	0	0	1	Status Register B (SRB)	Clock Select Reg. B (CSRB)
1	0	1	0	*Reserved*	Command Register B (CRB)
1	0	1	1	Rx Holding Register B (RHRB)	Tx Holding Register B (THRB)
1	1	0	0	Interrupt Vector Reg. (IVR)	Interrupt Vector Reg. (IVR)
1	1	0	1	Input Port	Output Port Conf. Reg. (OPCR)
1	1	1	0	Start Counter Command	Set Output Port Bits Command
1	1	1	1	Stop Counter Command	Reset Output Port Bits Command

RHR is read. Therefore the status register should be read prior to reading the FIFO.

If the FIFO is full when a new character is received, that character is held in the receive shift register until a FIFO position is available. If an additional character is received while this state exists, the contents of the FIFO are not affected: the character previously in the shift register is lost and the overrun error status bit (SP[4]) will be set upon receipt of the start bit of the new (overrunning) character.

The receiver can control the deactivation of RTS. If programmed to operate in this mode, the RTSN output will be negated when a valid start bit was received and the FIFO is full. When a FIFO position becomes available, the RTSN output will be re-asserted automatically. This feature can be used to prevent an overrun, in the receiver, by connecting the RTSN output to the CTSN input of the transmitting device.

If the receiver is disabled, the FIFO characters can be read. However, no additional characters can be received until the receiver is enabled again. If the receiver is reset, the FIFO and all of the receiver status, and the corresponding output ports and interrupt are reset. No additional characters can be received until the receiver is enabled again.

### Multidrop Mode

The DUART is equipped with a wake up mode used for multidrop applications. This

mode is selected by programming bits MR1A[4:3] or MR1B[4:3] to '11' for channels A and B respectively. In this mode of operation, a 'master' station transmits an address character followed by data characters for the addressed 'slave' station. The slave stations, with receivers that are normally disabled, examine the received data stream and 'wake-up' the CPU (by setting RxRDY) only upon receipt of an address character. The CPU compares the received address to its station address and enables the receiver if it wishes to receive the subsequent data characters. Upon receipt of another address character, the CPU may disable the receiver to initiate the process again.

A transmitted character consists of a start bit, the programmed number of data bits, an address/data (A/D) bit, and the programmed number of stop bits. The polarity of the transmitted A/D bit is selected by the CPU by programming bit MR1A[2]/MR1B[2]. MR1A[2]/MR1B[2] = 0 transmits a zero in the A/D bit position, which identifies the corresponding data bits as data, while MR1A[2]/MR1B[2] = 1 transmits a one in the A/D bit position, which identifies the corresponding data bits as an address. The CPU should program in the mode register prior to loading the corresponding data bits into the THR.

In this mode, the receiver continuously looks at the received data stream, whether it is enabled or disabled. If disabled, it sets the

RxRDY status bit and loads the character into the RHR FIFO if the received A/D bit is a one (address tag), but discards the received character if the received A/D bit is a zero (data tag). If enabled, all received characters are transferred to the CPU via the RHR. In either case, the data bits are loaded into the data FIFO while the A/D bit is loaded into the status FIFO position normally used for parity error (SRA[5] or SRB[5]). Framing error, overrun error, and break detect operate normally whether or not the receiver is enabled.

### PROGRAMMING

The operation of the DUART is programmed by writing control words into the appropriate registers. Operational feedback is provided via status registers which can be read by the CPU. The addressing of the registers is described in Table 1.

The contents of certain control registers are initialized to zero on RESET. Care should be exercised if the contents of a register are changed during operation, since certain changes may cause operational problems. For example, changing the number of bits per character while the transmitter is active may cause the transmission of an incorrect character. In general, the contents of the MR, the CSR, and the OPCR should only be changed while the receiver(s) and transmitter(s) are not enabled, and certain changes to the ACR should only be made while the C/T is stopped.

Mode registers 1 and 2 of each channel are accessed via independent auxiliary pointers. The pointer is set to MR1x by RESET or by issuing a 'reset pointer' command via the corresponding command register. Any read or write of the mode register while the pointer is at MR1x switches the pointer to MR2x. the pointer then remains at MR2x, so that subsequent accesses are always to MR2x unless the pointer is reset to MR1x as described above.

Mode, command, clock select, and status registers are duplicated for each channel to provide total independent operation and control. Refer to Table 2 for register bit descriptions. The reserved registers at addresses 'H02' and 'H0A' should never be read during normal operation since they are reserved for internal diagnostics.

## Dual Asynchronous Receiver/Transmitter (DUART)

SCN68681

Table 2. Register Bit Formats

	BIT 7	BIT 6	BIT 5	BIT 4	BIT 3	BIT 2	BIT 1	BIT 0
	<b>RxRTS CONTROL</b>	<b>RxINT SELECT</b>	<b>ERROR MODE</b>	<b>PARITY MODE</b>		<b>PARITY TYPE</b>	<b>BITS PER CHARACTER</b>	
MR1A MR1B	0=no 1=yes	0=RxDY 1=FFULL	0=char 1=block	00 = with parity 01 = force parity 10 = no parity 11 = multi-drop mode		0=even 1=odd	00=5 01=6 10=7 11=8	

	BIT 7	BIT 6	BIT 5	BIT 4	BIT 3	BIT 2	BIT 1	BIT 0
	<b>CHANNEL MODE</b>		<b>TxRTS CONTROL</b>	<b>CTS ENABLE Tx</b>	<b>STOP BIT LENGTH*</b>			
MR2A MR2B	00=Normal 01=Auto echo 10=Local loop 11=Remote loop		0=no 1=yes	0=no 1=yes	0=0.563 1=0.625 2=0.688 3=0.750	4=0.813 5=0.875 6=0.938 7=1.000	8=1.563 9=1.625 A=1.688 B=1.750	C=1.813 D=1.875 E=1.938 F=2.000

## NOTE:

\*Add 0.5 to values shown for 0-7 if channel is programmed for 5 bits/char.

	BIT 7	BIT 6	BIT 5	BIT 4	BIT 3	BIT 2	BIT 1	BIT 0
	<b>RECEIVER CLOCK SELECT</b>				<b>TRANSMITTER CLOCK SELECT</b>			
CSRA CSRB	See Text				See Text			

	BIT 7	BIT 6	BIT 5	BIT 4	BIT 3	BIT 2	BIT 1	BIT 0
	not used— must be 0	<b>MISCELLANEOUS COMMANDS</b>			<b>DISABLE Tx</b>	<b>ENABLE Tx</b>	<b>DISABLE Rx</b>	<b>ENABLE Rx</b>
CRA CRB		See Text			0=no 1=yes	0=no 1=yes	0=no 1=yes	0=no 1=yes

	BIT 7	BIT 6	BIT 5	BIT 4	BIT 3	BIT 2	BIT 1	BIT 0
	<b>RECEIVED BREAK</b>	<b>FRAMING ERROR</b>	<b>PARITY ERROR</b>	<b>OVERRUN ERROR</b>	<b>TxE<sub>MT</sub></b>	<b>TxRDY</b>	<b>FFULL</b>	<b>RxDY</b>
SRA SRB	0=no 1=yes *	0=no 1=yes *	0=no 1=yes *	0=no 1=yes	0=no 1=yes	0=no 1=yes	0=no 1=yes	0=no 1=yes

## NOTE:

\*These status bits are appended to the corresponding data character in the receive FIFO. A read of the status register provides these bits (7:5) from the top of the FIFO together with bits 4:0. These bits are cleared by a 'reset error status' command. In character mode they are discarded when the corresponding data character is read from the FIFO.

	BIT 7	BIT 6	BIT 5	BIT 4	BIT 3	BIT 2	BIT 1	BIT 0
	<b>OP7</b>	<b>OP6</b>	<b>OP5</b>	<b>OP4</b>	<b>OP3</b>		<b>OP2</b>	
OPCR	0 = OPR[7] 1 = TxRDYB	0 = OPR[6] 1 = TxRDYA	0 = OPR[5] 1 = RxRDY/ FFULLB	0 = OPR[4] 1 = RxRDY/ FFULLA	00 = OPR[3] 01 = C/T OUTPUT 10 = TxCB(1 × ) 11 = RxCB(1 × )		00 = OPR[2] 01 = TxCA(16 × ) 10 = TxCA(1 × ) 11 = RxCA(1 × )	

	BIT 7	BIT 6	BIT 5	BIT 4	BIT 3	BIT 2	BIT 1	BIT 0
	<b>BRG SET SELECT</b>	<b>COUNTER/TIMER MODE AND SOURCE</b>			<b>DELTA IP3 INT</b>	<b>DELTA IP2 INT</b>	<b>DELTA IP1 INT</b>	<b>DELTA IP0 INT</b>
ACR	0 = set1 1 = set2	See Table 4			0 = off 1 = on	0 = off 1 = on	0 = off 1 = on	0 = off 1 = on

## Dual Asynchronous Receiver/Transmitter (DUART)

SCN68681

2

Table 2. Register Bit Formats (Continued)

	BIT 7	BIT 6	BIT 5	BIT 4	BIT 3	BIT 2	BIT 1	BIT 0
IPCR	$\Delta$ IP3	$\Delta$ IP2	$\Delta$ IP1	$\Delta$ IP0	IP3	IP2	IP1	IP0
	0 = no 1 = yes	0 = no 1 = yes	0 = no 1 = yes	0 = no 1 = yes	0 = low 1 = high	0 = low 1 = high	0 = low 1 = high	0 = low 1 = high
ISR	BIT 7	BIT 6	BIT 5	BIT 4	BIT 3	BIT 2	BIT 1	BIT 0
	INPUT PORT CHANGE	$\Delta$ BREAK B	RxRDY/FFULLB	TxRDYB	COUNTER READY	$\Delta$ BREAK A	RxRDY/FFULLA	TxRDYA
	0=no 1=yes	0=no 1=yes	0=no 1=yes	0=no 1=yes	0=no 1=yes	0=no 1=yes	0=no 1=yes	0=no 1=yes
IMR	BIT 7	BIT 6	BIT 5	BIT 4	BIT 3	BIT 2	BIT 1	BIT 0
	IN. PORT CHANGE INT	$\Delta$ BREAK B INT	RxRDY/FFULLB INT	TxRDYB INT	COUNTER READY INT	$\Delta$ BREAK A INT	RxRDY/FFULLA INT	TxRDYA INT
	0=off 1=on	0=off 1=on	0=off 1=on	0=off 1=on	0=off 1=on	0=off 1=on	0=off 1=on	0=off 1=on
CTUR	BIT 7	BIT 6	BIT 5	BIT 4	BIT 3	BIT 2	BIT 1	BIT 0
	C/T[15]	C/T[14]	C/T[13]	C/T[12]	C/T[11]	C/T[10]	C/T[9]	C/T[8]
CTLR	BIT 7	BIT 6	BIT 5	BIT 4	BIT 3	BIT 2	BIT 1	BIT 0
	C/T[7]	C/T[6]	C/T[5]	C/T[4]	C/T[3]	C/T[2]	C/T[1]	C/T[0]
IVR	BIT 7	BIT 6	BIT 5	BIT 4	BIT 3	BIT 2	BIT 1	BIT 0
	IVR[7]	IVR[6]	IVR[5]	IVR[4]	IVR[3]	IVR[2]	IVR[1]	IVR[0]

### MR1A — Channel A Mode Register 1

MR1A is accessed when the channel A MR pointer points to MR1. The pointer is set to MR1 by RESET or by a 'set pointer' command applied via CRA. After reading or writing MR1A, the pointer will point to MR2A.

#### MR1A[7] — Channel A Receiver Request-to-Send Control

This bit controls the deactivation of the RTSAN output (OP0) by the receiver. This output is normally asserted by setting OPR[0] and negated by resetting OPR[0].

MR1A[7] = 1 causes RTSAN to be negated upon receipt of a valid start bit if the channel A FIFO is full. However, OPR[0] is not reset and RTSAN will be asserted again when an empty FIFO position is available. This feature can be used for flow control to prevent

overrun in the receiver by using the RTSAN output signal to control the CTSN input of the transmitting device.

#### MR1A[6] — Channel A Receiver Interrupt Select

This bit selects either the channel A receiver ready status (RxRDY) or the channel A FIFO full status (FFULL) to be used for CPU interrupts. It also causes the selected bit to be output on OP4 if it is programmed as an interrupt output via the OPCR.

#### MR1A[5] — Channel A Error Mode Select

This bit selects the operating mode of the three FIFOed status bits (FE, PE, received break) for channel A. In the 'character' mode, status is provided on a character-by-character basis: the status applies only to the character at the top of the FIFO. In the 'block'

mode, the status provided in the SR for these bits is the accumulation (logical-OR) of the status for all characters coming to the top of the FIFO since the last 'reset error' command for channel A was issued.

#### MR1A[4:3] — Channel A Parity Mode Select

If 'with parity' or 'force parity' is selected, a parity bit is added to the transmitted character and the receiver performs a parity check on incoming data. MR1A[4:3] = 11 selects channel A to operate in the special multidrop mode described in the Operation section.

#### MR1A[2] — Channel A Parity Type Select

This bit selects the parity type (odd or even) if the 'with parity' mode is programmed by MR1A[4:3], and the polarity of the forced parity bit if the 'force parity' mode is pro-

## Dual Asynchronous Receiver/Transmitter (DUART)

SCN68684

grammed. It has no effect if the 'no parity' mode is programmed. In the special multidrop mode it selects the polarity of the A/D bit.

#### MR1A[1:0] — Channel A Bits per Character Select

This field selects the number of data bits per character to be transmitted and received. The character length does not include the start, parity, and stop bits.

#### MR2A — Channel A Mode Register 2

MR2A is accessed when the channel A MR pointer points to MR2, which occurs after any access to MR1A. Accesses to MR2A do not change the pointer.

#### MR2A[7:6] — Channel A Mode Select

Each channel of the DUART can operate in one of four modes. MR2A[7:6] = 00 is the normal mode, with the transmitter and receiver operating independently. MR2A[7:6] = 01 places the channel in the automatic echo mode, which automatically retransmits the received data. The following conditions are true while in automatic echo mode:

1. Received data is relocked and retransmitted on the TxDA output.
2. The receive clock is used for the transmitter.
3. The receiver must be enabled, but the transmitter need not be enabled.
4. The channel A TxRDY and TxEMT status bits are inactive.
5. The received parity is checked, but is not regenerated for transmission, i.e., transmitted parity bit is as received.
6. Character framing is checked, but the stop bits are retransmitted as received.
7. A received break is echoed as received until the next valid start bit is detected.
8. CPU to receiver communication continues normally, but the CPU to transmitter link is disabled.

Two diagnostic modes can also be configured. MR2A[7:6] = 10 selects local loopback mode. In this mode:

1. The transmitter output is internally connected to the receiver input.
2. The transmit clock is used for the receiver.
3. The TxDA output is held high.
4. The RxDA input is ignored.
5. The transmitter must be enabled, but the receiver need not be enabled.
6. CPU to transmitter and receiver communications continue normally.

The second diagnostic mode is the remote loopback mode, selected by MR2A[7:6] = 11. In this mode:

1. Received data is relocked and retransmitted on the TxDA output.

2. The receive clock is used for the transmitter.
3. Received data is not sent to the local CPU, and the error status conditions are inactive.
4. The received parity is not checked and is not regenerated for transmission; i.e., transmitted parity bit is as received.
5. The receiver must be enabled.
6. Character framing is not checked, and the stop bits are retransmitted as received.
7. A received break is echoed as received until the next valid start bit is detected.

The user must exercise care when switching into and out of the various modes. The selected mode will be activated immediately upon mode selection, even if this occurs in the middle of a received or transmitted character. Likewise, if a mode is deselected, the device will switch out of the mode immediately. An exception to this is switching out of autoecho or remote loopback modes: if the de-selection occurs just after the receiver has sampled the stop bit (indicated in autoecho by assertion of RxRDY), and the transmitter is enabled, the transmitter will remain in autoecho mode until the entire stop bit has been retransmitted.

#### MR2A[5] — Channel A Transmitter Request-to-Send Control

This bit controls the deactivation of the RTSAN output (OP0) by the transmitter. This output is normally asserted by setting OPR[0] and negated by resetting OPR[0]. MR2A[5] = 1 causes OPR[0] to be reset automatically one bit time after the characters in the channel A transmit shift register and in the THR, if any, are completely transmitted, including the programmed number of stop bits, if the transmitter is not enabled. This feature can be used to automatically terminate the transmission of a message as follows:

1. Program auto-reset mode: MR2A[5] = 1.
2. Enable transmitter.
3. Assert RTSAN: OPR[0] = 1.
4. Send message.
5. Verify the message is sent by waiting until the transmit ready status (TxRDY) is asserted. Disable transmitter after the last character is loaded into the channel A THR.
6. The last character will be transmitted and OPR[0] will be reset one bit time after the last stop bit, causing RTSAN to be negated.

#### MR2A[4] — Channel A Clear-to-Send Control

If this bit is 0, CTSAN has no effect on the transmitter. If this bit is a 1, the transmitter checks the state of CTSAN (IP0) each time it

is ready to send a character. If IP0 is asserted (low), the character is transmitted. If it is negated (high), the TxDA output remains in the marking state and the transmission is delayed until CTSAN goes low. Changes in CTSAN while a character is being transmitted do not affect the transmission of that character.

#### MR2A[3:0] — Channel A Stop Bit Length Select

This field programs the length of the stop bit appended to the transmitted character. Stop bit lengths of  $\frac{9}{16}$  to 1 and  $\frac{19}{16}$  to 2 bits, in increments of  $\frac{1}{16}$  bit, can be programmed for character lengths of 6, 7, and 8 bits. For a character length of 5 bits,  $\frac{1}{16}$  to 2 stop bits can be programmed in increments of  $\frac{1}{16}$  bit. The receiver only checks for a 'mark' condition at the center of the first stop bit position (one bit time after the last data bit, or after the parity bit if parity is enabled) in all cases.

If an external  $1 \times$  clock is used for the transmitter, MR2A[3] = 0 selects one stop bit and MR2A[3] = 1 selects two stop bits to be transmitted.

#### MR1B — Channel B Mode Register 1

MR1B is accessed when the channel B MR pointer points to MR1. The pointer is set to MR1 by RESET or by a 'set pointer' command applied via CRB. After reading or writing MR1B, the pointer will point to MR2B.

The bit definitions for this register are identical to the bit definitions for MR1A, except that all control actions apply to the channel B receiver and transmitter and the corresponding inputs and outputs.

#### MR2B — Channel B Mode Register 2

MR2B is accessed when the channel B MR pointer points to MR2, which occurs after any access to MR1B. Accesses to MR2B do not change the pointer.

The bit definitions for this register are identical to the bit definitions for MR2A, except that all control actions apply to the channel B receiver and transmitter and the corresponding inputs and outputs.

#### CSRA — Channel A Clock Select Register

##### CSRA[7:4] — Channel A Receiver Clock Select

This field selects the baud rate clock for the channel A receiver as follows:



## Dual Asynchronous Receiver/Transmitter (DUART)

SCN68681

Baud Rate		
Clock = 3.6864MHz		
CSRA[7:4]	ACR[7] = 0	ACR[7] = 1
0 0 0 0	50	75
0 0 0 1	110	110
0 0 1 0	134.5	134.5
0 0 1 1	200	150
0 1 0 0	300	300
0 1 0 1	600	600
0 1 1 0	1,200	1,200
0 1 1 1	1,050	2,000
1 0 0 0	2,400	2,400
1 0 0 1	4,800	4,800
1 0 1 0	7,200	1,800
1 0 1 1	9,600	9,600
1 1 0 0	38.4k	19.2k
1 1 0 1	Timer	Timer
1 1 1 0	IP4 — 16×	IP4 — 16×
1 1 1 1	IP4 — 1×	IP4 — 1×

The receiver clock is always a 16× clock except for CSRA[7:4] = 1111.

#### CSRA[3:0] — Channel A Transmitter Clock Select

This field selects the baud rate clock for the channel A transmitter. The field definition is as per CSRA[7:4] except as follows:

Baud Rate		
CSRA[3:0]	ACR[7] = 0	ACR[7] = 1
1 1 1 0	IP3 — 16×	IP3 — 16×
1 1 1 1	IP3 — 1×	IP3 — 1×

The transmitter clock is always a 16× clock except for CSRA[3:0] = 1111.

#### CSRB — Channel B Clock Select Register

##### CSRB[7:4] — Channel B Receiver Clock Select

This field selects the baud rate clock for the channel B receiver. The field definition is as per CSRA[7:4] except as follows:

Baud Rate		
CSRB[7:4]	ACR[7] = 0	ACR[7] = 1
1 1 1 0	IP2 — 16×	IP2 — 16×
1 1 1 1	IP2 — 1×	IP2 — 1×

The receiver clock is always a 16× clock except for CSRB[7:4] = 1111.

##### CSRB[3:0] — Channel B Transmitter Clock Select

This field selects the baud rate clock for the channel B transmitter. The field definition is as per CSRA[7:4] except as follows:

Baud Rate		
CSRB[3:0]	ACR[7] = 0	ACR[7] = 1
1 1 1 0	IP5 — 16×	IP5 — 16×
1 1 1 1	IP5 — 1×	IP5 — 1×

The transmitter clock is always a 16× clock except for CSRB[3:0] = 1111

#### CRA — Channel A Command Register

CRA is a register used to supply commands to channel A. Multiple commands can be

specified in a single write to CRA as long as the commands are non-conflicting; e.g., the 'enable transmitter' and 'reset transmitter' commands cannot be specified in a single command word.

#### CRA[6:4] — Channel A Miscellaneous Commands

The encoded value of this field may be used to specify a single command as follows:

##### CRA[6:4] COMMAND

0 0 0 No command.  
 0 0 1 Reset MR pointer. Causes the channel A MR pointer to point to MR1.  
 0 1 0 Reset receiver. Resets the channel A receiver as if a hardware reset had been applied. The receiver is disabled and the FIFO pointers are reset.

0 1 1 Reset transmitter. Resets the channel A transmitter as if a hardware reset had been applied.

1 0 0 Reset error status. Clears the channel A Received Break, Parity Error, Framing Error, and Overrun Error bits in the status register (SRA[7:4]). Used in character mode to clear OE status (although RB, PE, and FE bits will also be cleared) and in block mode to clear all error status after a block of data has been received.

1 0 1 Reset channel A break change interrupt. Causes the channel A break detect change bit in the interrupt status register (ISR[2]) to be cleared to zero.

1 1 0 Start Break. Forces the TxDA output low (spacing). If the transmitter is empty the start of the break condition will be delayed up to two bit times. If the transmitter is active the break begins when transmission of the character is completed. If a character is in the THR, the start of the break will be delayed until that character, or any others loaded subsequently are transmitted. The transmitter must be enabled for this command to be accepted.  
 1 1 1 Stop Break. The TxDA line will go high (marking) within two bit times. TxDA will remain high for one bit time before the next character, if any, is transmitted.

#### CRA[3] — Disable Channel A Transmitter

This command terminates transmitter operation and resets the TxRDY and TxEMT status bits. However, if a character is being transmitted or if a character is in the THR when the transmitter is disabled, the transmission of

the character(s) is completed before assuming the inactive state.

#### CRA[2] — Enable Channel A Transmitter

Enables operation of the channel A transmitter. The TxRDY status bit will be asserted.

#### CRA[1] — Disable Channel A Receiver

This command terminates operation of the receiver immediately — a character being received will be lost. The command has no effect on the receiver status bits or any other control registers. If the special multidrop mode is programmed, the receiver operates even if it is disabled. See Operation section.

#### CRA[0] — Enable Channel A Receiver

Enables operation of the channel A receiver. If not in the special wake-up mode, this also forces the receiver into the search for start-bit state.

#### CRB — Channel B Command Register

CRB is a register used to supply commands to channel B. Multiple commands can be specified in a single write to CRB as long as the commands are non-conflicting; e.g., the 'enable transmitter' and 'reset transmitter' commands cannot be specified in a single command word.

The bit definitions for this register are identical to the bit definitions for CRA, except that all control actions apply to the channel B receiver and transmitter and the corresponding inputs and outputs.

#### SRA — Channel A Status Register

##### SRA[7] — Channel A Received Break

This bit indicates that an all zero character of the programmed length has been received without a stop bit. Only a single FIFO position is occupied when a break is received: further entries to the FIFO are inhibited until the RxDA line returns to the marking state for at least one-half a bit time (two successive edges of the internal or external 1× clock).

When this bit is set, the channel A 'change in break' bit in the ISR (ISR[2]) is set. ISR[2] is also set when the end of the break condition, as defined above, is detected.

The break detect circuitry can detect breaks that originate in the middle of a received character. However, if a break begins in the middle of a character, it must persist until at least the end of the next character time in order for it to be detected.

##### SRA[6] — Channel A Framing Error

This bit, when set, indicates that a stop bit was not detected when the corresponding data character in the FIFO was received. The stop bit check is made in the middle of the first stop bit position.

## Dual Asynchronous Receiver/Transmitter (DUART)

SCN68681

**SRA[5] — Channel A Parity Error**

This bit is set when the 'with parity' or 'force parity' mode is programmed and the corresponding character in the FIFO was received with incorrect parity.

In the special multidrop mode the parity error bit stores the received A/D bit.

**SRA[4] — Channel A Overrun Error**

This bit, when set, indicates that one or more characters in the received data stream have been lost. It is set upon receipt of a new character when the FIFO is full and a character is already in the receive shift register waiting for an empty FIFO position. When this occurs, the character in the receive shift register (and its break detect, parity error and framing error status, if any) is lost.

This bit is cleared by a 'reset error status' command.

**SRA[3] — Channel A Transmitter Empty (TxEMTA)**

This bit will be set when the channel A transmitter underruns; i.e., both the transmit holding register (THR) and the transmit shift register are empty. It is set after transmission of the last stop bit of a character if no character is in the THR awaiting transmission. It is reset when the THR is loaded by the CPU or when the transmitter is disabled.

**SRA[2] — Channel A Transmitter Ready (TxRDYA)**

This bit, when set, indicates that the THR is empty and ready to be loaded with a character. This bit is cleared when the THR is loaded by the CPU and is set when the character is transferred to the transmit shift register. TxRDY is reset when the transmitter is disabled and is set when the transmitter is first enabled, viz., characters loaded into the THR while the transmitter is disabled will not be transmitted.

**SRA[1] — Channel A FIFO Full (FFULLA)**

This bit is set when a character is transferred from the receive shift register to the receive FIFO and the transfer causes the FIFO to become full; i.e., all three FIFO positions are occupied. It is reset when the CPU reads the RHR. If a character is waiting in the receive shift register because the FIFO is full, FFULL will not be reset when the CPU reads the RHR.

**SRA[0] — Channel A Receiver Ready (RxRDYA)**

This bit indicates that a character has been received and is waiting in the FIFO to be read by the CPU. It is set when the character is transferred from the receive shift register to the FIFO and reset when the CPU reads the RHR, only if (after this read) there are no more characters still in the FIFO.

**SRB — Channel B Status Register**

The bit definitions for this register are identical to the bit definitions for SRA, except that all status applies to the channel B receiver and transmitter and the corresponding inputs and outputs.

**OPCR — Output Port Configuration Register****OPCR[7] — OP7 Output Select**

This bit programs the OP7 output to provide one of the following:

- The complement of OPR[7]
- The channel B transmitter interrupt output, which is the complement of TxRDYB. When in this mode OP7 acts as an open-drain output. Note that this output is not masked by the contents of the IMR.

**OPCR[6] — OP6 Output Select**

This bit programs the OP6 output to provide one of the following:

- The complement of OPR[6]
- The channel A transmitter interrupt output, which is the complement of TxRDYA. When in this mode OP6 acts as an open-drain output. Note that this output is not masked by the contents of the IMR.

**OPCR[5] — OP5 Output Select**

This bit programs the OP5 output to provide one of the following:

- The complement of OPR[5]
- The channel B receiver interrupt output, which is the complement of ISR[5]. When in this mode OP5 acts as an open-drain output. Note that this output is not masked by the contents of the IMR.

**OPCR[4] — OP4 Output Select**

This bit programs the OP4 output to provide one of the following:

- The complement of OPR[4]
- The channel A receiver interrupt output, which is the complement of ISR[1]. When in this mode OP4 acts as an open-drain output. Note that this output is not masked by the contents of the IMR.

**OPCR[3:2] — OP3 Output Select**

This field programs the OP3 output to provide one of the following:

- The complement of OPR[3]
- The counter/timer output, in which case OP3 acts as an open-drain output. In the timer mode, this output is a square wave at the programmed frequency. In the counter mode, the output remains high until terminal count is reached, at which time it goes low. The output returns to the high state when the counter is stopped by a stop counter command. Note that this output is not masked by the contents of the IMR.
- The 1× clock for the channel B transmitter, which is the clock that shifts the transmitted

data. If data is not being transmitted, a free running 1× clock is output.

- The 1× clock for the channel B receiver, which is the clock that samples the received data. If data is not being received, a free running 1× clock is output.

**OPCR[1:0] — OP2 Output Select**

This field programs the OP2 output to provide one of the following:

- The complement of OPR[2]
- The 16× clock for the channel A transmitter. This is the clock selected by CSRA[3:0], and will be 1× clock if CSRA[3:0] = 1111.
- The 1× clock for the channel A transmitter, which is the clock that shifts the transmitted data. If data is not being transmitted, a free running 1× clock is output.
- The 1× clock for the channel A receiver, which is the clock that samples the received data. If data is not being received, a free running 1× clock is output.

**ACR — Auxiliary Control Register****ACR[7] — Baud Rate Generator Set Select**

This bit selects one of two sets of baud rates to be generated by the BRG:

Set 1: 50, 110, 134.5, 200, 300, 600, 1.05k, 1.2k, 2.4k, 4.8k, 7.2k, 9.6k, and 38.4k baud.

Set 2: 75, 110, 134.5, 150, 300, 600, 1.2k, 1.8k, 2.0k, 2.4k, 4.8k, 9.6k, and 19.2k baud.

The selected set of rates is available for use by the channel A and B receivers and transmitters as described in CSRA and CSRB. Baud rate generator characteristics are given in Table 3.

**ACR[6:4] — Counter/Timer Mode and Clock Source Select**

This field selects the operating mode of the counter/timer and its clock source as shown in Table 4.

**ACR[3:0] — IP3, IP2, IP1, IP0 Change of State Interrupt Enable**

This field selects which bits of the Input Port Change register (IPCR) cause the input change bit in the interrupt status register (ISR[7]) to be set. If a bit is in the 'on' state, the setting of the corresponding bit in the IPCR will also result in the setting of ISR[7], which results in the generation of an interrupt output if IMR[7] = 1. If a bit is in the 'off' state, the setting of that bit in the IPCR has no effect on ISR[7].

## Dual Asynchronous Receiver/Transmitter (DUART)

SCN68681

**Table 3. Baud Rate Generator Characteristics Crystal or Clock = 3.6864MHz**

NOMINAL RATE (BAUD)	ACTUAL 16X CLOCK (KHz)	ERROR (PERCENT)
50	0.8	0
75	1.2	0
110	1.759	-0.069
134.5	2.153	0.059
150	2.4	0
200	3.2	0
300	4.8	0
600	9.6	0
1050	16.756	-0.260
1200	19.2	0
1800	28.8	0
2000	32.056	0.175
2400	38.4	0
4800	76.8	0
7200	115.2	0
9600	153.6	0
19.2k	307.2	0
38.4k	614.4	0

**NOTE:**

Duty cycle of 16X clock is 50% ± 1%

**Table 4. ACR [6:4] Field Definition**

ACR [6:4]	MODE	CLOCK SOURCE
0 0 0	Counter	External (IP2) <sup>1</sup>
0 0 1	Counter	TxCA — 1X clock of channel A transmitter
0 1 0	Counter	TxCB — 1X clock of channel B transmitter
0 1 1	Counter	Crystal or external clock (X1/CLK) divided by 16
1 0 0	Timer	External (IP2) <sup>1</sup>
1 0 1	Timer	External (IP2) divided by 16 <sup>1</sup>
1 1 0	Timer	Crystal or external clock (X1/CLK)
1 1 1	Timer	Crystal or external clock (X1/CLK) divided by 16

**NOTE:**

1. In these modes, the channel B receiver clock should normally be generated from the baud rate generator.

**IPCR — Input Port Change Register****IPCR[7:4] — IP3, IP2, IP1, IP0 Change of State**

These bits are set when a change of state, as defined in the Input Port section of this data sheet, occurs at the respective input pins. They are cleared when the IPCR is read by the CPU. A read of the IPCR also clears ISR[7], the input change bit in the interrupt status register.

The setting of these bits can be programmed to generate an interrupt to the CPU.

**IPCR[3:0] — IP3, IP2, IP1, IP0 Current State**

These bits provide the current state of the respective inputs. The information is unlatched and reflects the state of the input pins at the time the IPCR is read.

**ISR — Interrupt Status Register**

This register provides the status of all potential interrupt sources. The contents of this

register are masked by the interrupt mask register (IMR). If a bit in the ISR is a '1' and the corresponding bit in the IMR is also a '1', the INTRN output will be asserted. If the corresponding bit in the IMR is a zero, the state of the bit in the ISR has no effect on the INTRN output. Note that the IMR does not mask the reading of the ISR — the true status will be provided regardless of the contents of the IMR. The contents of this register are initialized to 00<sub>16</sub> when the DUART is reset.

**ISR[7] — Input Port Change Status**

This bit is a '1' when a change of state has occurred at the IP0, IP1, IP2, or IP3 inputs and that event has been selected to cause an interrupt by the programming of ACR[3:0]. The bit is cleared when the CPU reads the IPCR.

**ISR[6] — Channel B Change In Break**

This bit, when set, indicates that the channel B receiver has detected the beginning or the end of a received break. It is reset when the CPU issues a channel B 'reset break change interrupt' command.

**ISR[5] — Channel B Receiver Ready or FIFO Full**

The function of this bit is programmed by MR1B[6]. If programmed as receiver ready, it indicates that a character has been received in channel B and is waiting in the FIFO to be read by the CPU. It is set when the character is transferred from the receive shift register to the FIFO and reset when the CPU reads the RHR. If after this read there are more characters still in the FIFO the bit will be set again after the FIFO is 'popped'. If programmed as FIFO full, it is set when a character is transferred from the receive holding register to the receive FIFO and the transfer causes the channel B FIFO to become full; i.e., all three FIFO positions are occupied. It is reset when the CPU reads the RHR. If a character is waiting in the receive shift register because the FIFO is full, the bit will be set again when the waiting character is loaded into the FIFO.

**ISR[4] — Channel B Transmitter Ready**

This bit is a duplicate of TxRDYB (SRB[2]).

**ISR[3] — Counter Ready**

In the counter mode, this bit is set when the counter reaches terminal count and is reset when the counter is stopped by a stop counter command.

In the timer mode, this bit is set once each cycle of the generated square wave (every other time that the counter/timer reaches zero count). The bit is reset by a stop counter command. The command, however, does not stop the counter/timer.

**ISR[2] — Channel A Change In Break**

This bit, when set, indicates that the channel A receiver has detected the beginning or the end of a received break. It is reset when the CPU issues a channel A 'reset break change interrupt' command.

**ISR[1] — Channel A Receiver Ready or FIFO Full**

The function of this bit is programmed by MR1A[6]. If programmed as receiver ready, it indicates that a character has been received in channel A and is waiting in the FIFO to be read by the CPU. It is set when the character is transferred from the receive shift register to the FIFO and reset when the CPU reads the RHR. If after this read there are more characters still in the FIFO the bit will be set again after the FIFO is 'popped'. If programmed as FIFO full, it is set when a character is transferred from the receive holding register to the receive FIFO and the transfer causes the channel A FIFO to become full; i.e., all three FIFO positions are occupied. It is reset when the CPU reads the RHR. If a character is waiting in the receive shift register because the FIFO is full, the bit will be set again when the waiting character is loaded into the FIFO.

## Dual Asynchronous Receiver/Transmitter (DUART)

SCN68681

**ISR[0] — Channel A Transmitter Ready**

This bit is a duplicate of TxRDYA (SRA[2]).

**IMR — Interrupt Mask Register**

The programming of this register selects which bits in the ISR cause an interrupt output. If a bit in the ISR is a '1' and the corresponding bit in the IMR is also a '1', the INTRN output will be asserted. If the corresponding bit in the IMR is a zero, the state of the bit in the ISR has no effect on the INTRN output. Note that the IMR does not mask the programmable interrupt outputs OP3–OP7 or the reading of the ISR.

**CTUR and CTLR — Counter/Timer Registers**

The CTUR and CTLR hold the eight MSBs and eight LSBs respectively of the value to be used by the counter/timer in either the counter or timer modes of operation. The minimum value which may be loaded into the CTUR/CTLR registers is 0002<sub>16</sub>. Note that these registers are write-only and cannot be read by the CPU.

In the timer (programmable divider) mode, the C/T generates a square wave with a period of twice the value (in clock periods) of the CTUR and CTLR. If the value in CTUR or CTLR is changed, the current half-period will not be affected, but subsequent half periods will be.

In this mode the C/T runs continuously. Receipt of a start counter command (read with A4–A1 = 1110) causes the counter to terminate the current timing cycle and to begin a new cycle using the values in CTUR and CTLR. The counter ready status bit (ISR[3]) is set once each cycle of the square wave. The bit is reset by a stop counter command (read with A4–A1 = 1111). The command, however, does not stop the C/T. The generated square wave is output on OP3 if it is programmed to be the C/T output.

On power-up and after reset, the timer/counter runs in timer mode and can only be restarted. Because it cannot be shut off or stopped, and runs continuously in timer mode, it is recommended that at initialization, the output port, OP3, should be masked off through the OPCR[3:2] = 00 until the T/C is programmed to the desired operational state.

In the counter mode, the C/T counts down the number of pulses loaded into CTUR and CTLR by the CPU. Counting begins upon receipt of a start counter command. Upon reaching terminal count (0000<sub>16</sub>), the counter ready interrupt bit (ISR[3]) is set. The counter continues counting past the terminal count until stopped by the CPU. If OP3 is programmed to be the output of the C/T, the

output remains high until terminal count is reached, at which time it goes low. The output returns to the high state and ISR[3] is cleared when the counter is stopped by a stop counter command. The CPU may change the values of CTUR and CTLR at any time, but the new count becomes effective only on the next start counter command. If new values have not been loaded, the previous count values are preserved and used for the next count cycle.

In the counter mode, the current value of the upper and lower 8 bits of the counter (CTU, CTL) may be read by the CPU. It is recommended that the counter be stopped when reading to prevent potential problems which may occur if a carry from the lower 8 bits to the upper 8 bits occurs between the times that both halves of the counter are read. However, note that a subsequent start counter command will cause the counter to begin a new count cycle using the values in CTUR and CTLR.

**IVR — Interrupt Vector Register**

This register contains the interrupt vector. The register is initialized to H'0F' by RESET. The contents of the register are placed on the data bus when the DUART responds to a valid interrupt acknowledge cycle.

## Dual Asynchronous Receiver/Transmitter (DUART)

SCN68681

ABSOLUTE MAXIMUM RATINGS<sup>1</sup>

SYMBOL	PARAMETER	RATING	UNIT
T <sub>A</sub>	Operating ambient temperature <sup>2</sup> range	0 to +70	°C
T <sub>STG</sub>	Storage temperature range	-65 to +150	°C
	All voltages with respect to ground <sup>3</sup>	-0.5 to +6.0	V

## NOTES:

- Stresses above those listed under Absolute Maximum Ratings may cause permanent damage to the device. This is a stress rating only and functional operation of the device at these or any other condition above those indicated in the operation section of this specification is not implied.
- For operating at elevated temperatures, the device must be derated based on +150°C maximum junction temperature.
- This product includes circuitry specifically designed for the protection of its internal devices from damaging effects of excessive static charge. Nonetheless, it is suggested that conventional precautions be taken to avoid applying any voltages larger than the rated maxima.

DC ELECTRICAL CHARACTERISTICS T<sub>A</sub> = 0°C to +70°C, V<sub>CC</sub> = 5.0V ± 5%<sup>4, 5, 6</sup>

SYMBOL	PARAMETER	TEST CONDITIONS	LIMITS			UNIT
			Min	Typ	Max	
V <sub>IL</sub>	Input low voltage				0.8	V
V <sub>IH</sub>	Input high voltage (except X1/CLK)		2			V
V <sub>IH</sub>	Input high voltage (X1/CLK)		4			V
V <sub>OL</sub>	Output low voltage	I <sub>OL</sub> = 2.4mA			0.4	V
V <sub>OH</sub>	Output high voltage (except o.c. outputs)	I <sub>OH</sub> = -400µA	2.4			V
I <sub>IL</sub>	Input leakage current	V <sub>IN</sub> = 0 to V <sub>CC</sub>	-10		10	µA
I <sub>LL</sub>	Data bus 3-State leakage current	V <sub>O</sub> = 0.4 to V <sub>CC</sub>	-10		10	µA
I <sub>X1L</sub>	X1/CLK low input current	V <sub>IN</sub> = 0, X2 grounded	-4	-2	0	mA
		V <sub>IN</sub> = 0, X2 floated	-3	-1.5	0	mA
I <sub>X1H</sub>	X1/CLK high input current	V <sub>IN</sub> = V <sub>CC</sub> , X2 grounded	-1	0.2	1	mA
		V <sub>IN</sub> = V <sub>CC</sub> , X2 floated	0	3.5	10	mA
I <sub>X2L</sub>	X2 low input current	V <sub>IN</sub> = 0, X1/CLK floated	-100	-30	0	µA
I <sub>X2H</sub>	X2 high input current	V <sub>IN</sub> = V <sub>CC</sub> , X1/CLK floated	0	+30	100	µA
I <sub>OC</sub>	Open-collector output leakage current	V <sub>O</sub> = 0.4 to V <sub>CC</sub>	-10		10	µA
I <sub>CC</sub>	Power supply current				150	mA

## NOTES:

- Parameters are valid over specified temperature range.
- All voltage measurements are referenced to ground (GND). For testing, all inputs except X1/CLK swing between 0.4V and 2.4V with a transition time of 20ns maximum. For X1/CLK, this swing is between 0.4V and 4.4V. All time measurements are referenced at input voltages of 0.8V and 2V as appropriate.
- Typical values are at +25°C, typical supply voltages, and typical processing parameters.
- Test condition for outputs: C<sub>L</sub> = 150pF, except interrupt outputs. Test condition for interrupt outputs: C<sub>L</sub> = 50pF, R<sub>L</sub> = 2.7kΩ to V<sub>CC</sub>.
- This specification will impose maximum 68000 CPU CLK to 6MHz. Higher CPU CLK can be used if repeating bus reads are not performed. Consecutive write operations to the same command register require at least three edges of the X1 clock between writes.
- This specification imposes a lower bound on CSN and IACKN low, guaranteeing that it will be low for at least 1 CLK period. This requirement is made on CSN only to insure assertion of DTACKN and not to guarantee operation of the part.
- This specification is made only to insure that DTACKN is asserted with respect to the rising edge of the X1/CLK pin as shown in the timing diagram, not to guarantee operation of the part. If the setup time is violated, DTACKN may be asserted as shown, or may be asserted one clock cycle later.

## Dual Asynchronous Receiver/Transmitter (DUART)

SCN68681

AC ELECTRICAL CHARACTERISTICS  $T_A = 0^\circ\text{C}$  to  $+70^\circ\text{C}$ ,  $V_{CC} = 5.0\text{V} \pm 5\%$ <sup>4, 5, 6, 7</sup>

SYMBOL	PARAMETER	LIMITS			UNIT
		Min	Typ	Max	
<b>Reset timing (Figure 1)</b>					
$t_{RES}$	RESETN pulse width	1.0			$\mu\text{s}$
<b>Bus timing (Figures 2, 3, 4)</b>					
$t_{AS}$	A1-A4 setup time to CSN low	10			ns
$t_{AH}$	A1-A4 hold time from CSN high	0			ns
$t_{RWS}$	RWN setup time to CSN high	0			ns
$t_{RWH}$	RWN holdup time to CSN high	0			ns
$t_{CSW}^8$	CSN high pulse width	160			ns
$t_{CSD}^9$	CSN or IACKN high from DTACKN low	20			ns
$t_{DD}$	Data valid from CSN or IACKN low			175	ns
$t_{DF}$	Data bus floating from CSN or IACKN high			100	ns
$t_{DS}$	Data setup time to CLK high	100			ns
$t_{DH}$	Data hold time from CSN high	0			ns
$t_{DAL}$	DTACKN low from read data valid	0			ns
$t_{DCR}$	DTACKN low (read cycle) from CLK high			125	ns
$t_{DCW}$	DTACKN low (write cycle) from CLK high			125	ns
$t_{DAH}$	DTACKN high from CSN or IACKN high			100	ns
$t_{DAT}$	DTACKN high impedance from CSN or IACKN high			125	ns
$t_{CSC}^{10}$	CSN or IACKN setup time to clock high	90			ns
<b>Port timing (Figure 5)</b>					
$t_{PS}$	Port input setup time to CSN low	0			ns
$t_{PH}$	Port input hold time from CSN high	0			ns
$t_{PD}$	Port output valid from CSN high			400	ns
<b>Interrupt reset timing (Figure 6)</b>					
$t_{IR}$	INTRN, or OP3-OP7 when used as interrupts, negated from: Read RHR (RxRDY/FFULL interrupt) Write THR (TxRDY interrupt) Reset command (delta break interrupt) Stop C/T command (counter interrupt) Read IPCR (input port change interrupt) Write IMR (clear of interrupt mask bit)			300 300 300 300 300 300	ns ns ns ns ns ns
<b>Clock timing (Figure 7)</b>					
$t_{CLK}$	X1/CLK high or low time	100			ns
$f_{CLK}$	X1/CLK frequency	2	3.6864	4	MHz
$t_{CTC}$	CTCLK high or low time	100			ns
$f_{CTC}$	CTCLK frequency	0		4	MHz
$t_{RX}$	RxC high or low time	220			ns
$f_{RX}$	RxC frequency ( $16\times$ )	0		2	MHz
	( $1\times$ )	0		1	MHz
$t_{TX}$	TxC high or low time	220			ns
$f_{TX}$	TxC frequency ( $16\times$ )	0		2	MHz
	( $1\times$ )	0		1	MHz
<b>Transmitter timing (Figure 8)</b>					
$t_{TXD}$	TxD output delay from TxC low			350	ns
$t_{TCS}$	Output delay from TxC low to TxD data output			150	ns
<b>Receiver timing (Figure 9)</b>					
$t_{RXS}$	RxD data setup time to RxC high	240			ns
$t_{RXH}$	RxD data hold time from RxC high	200			ns

# Dual Asynchronous Receiver/Transmitter (DUART)

SCN68681

**2**

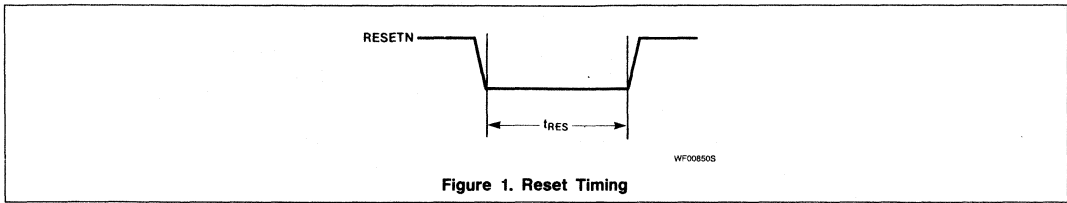

Figure 1. Reset Timing

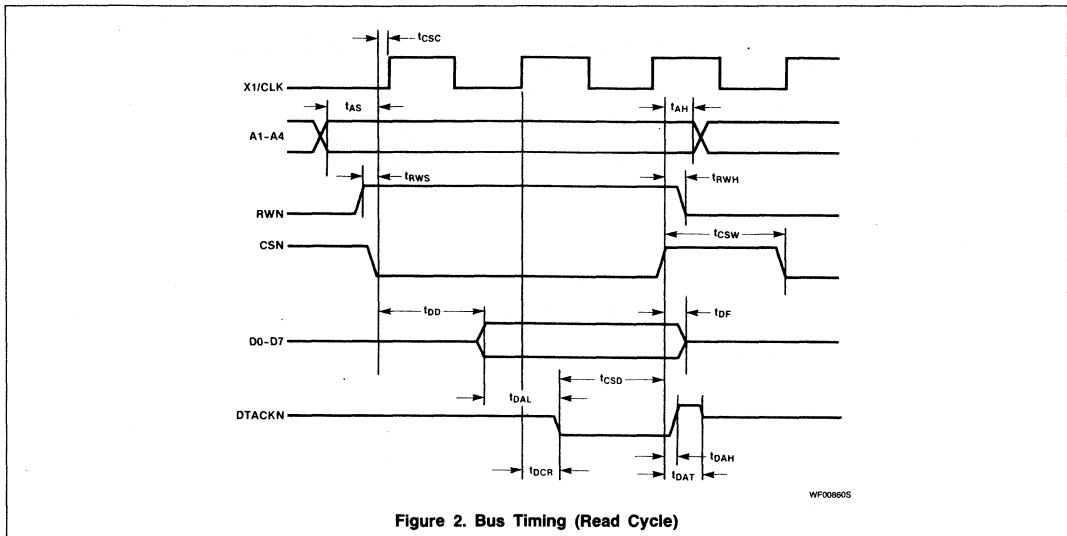

Figure 2. Bus Timing (Read Cycle)

# Dual Asynchronous Receiver/Transmitter (DUART)

SCN68681

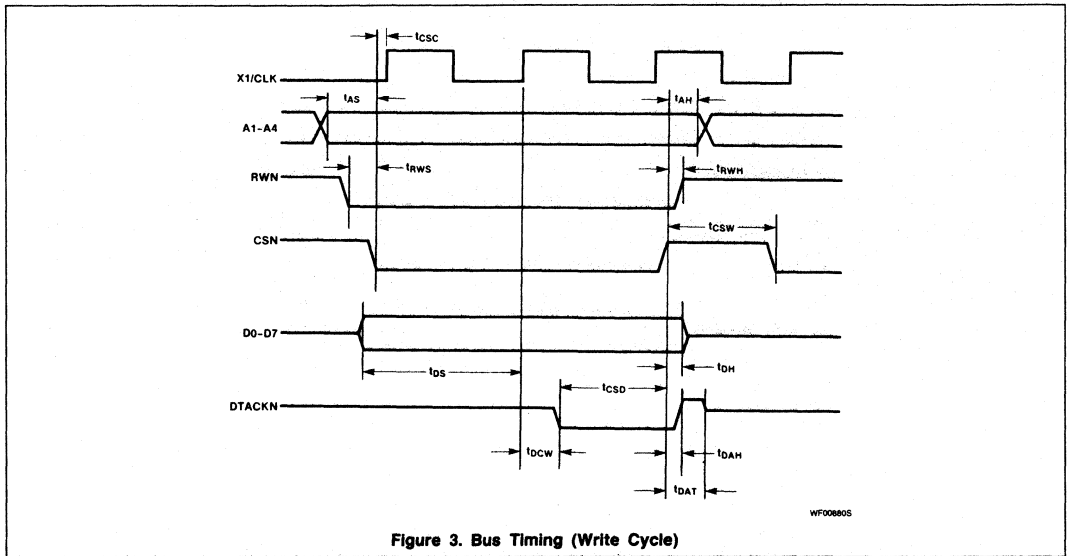

Figure 3. Bus Timing (Write Cycle)

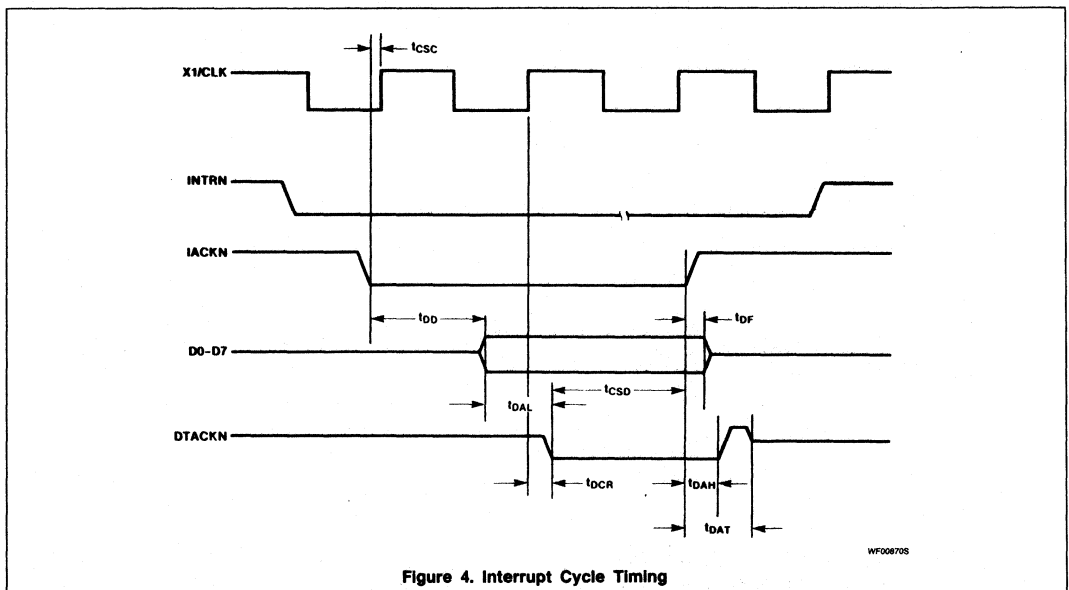

Figure 4. Interrupt Cycle Timing



# Dual Asynchronous Receiver/Transmitter (DUART)

SCN68681

2

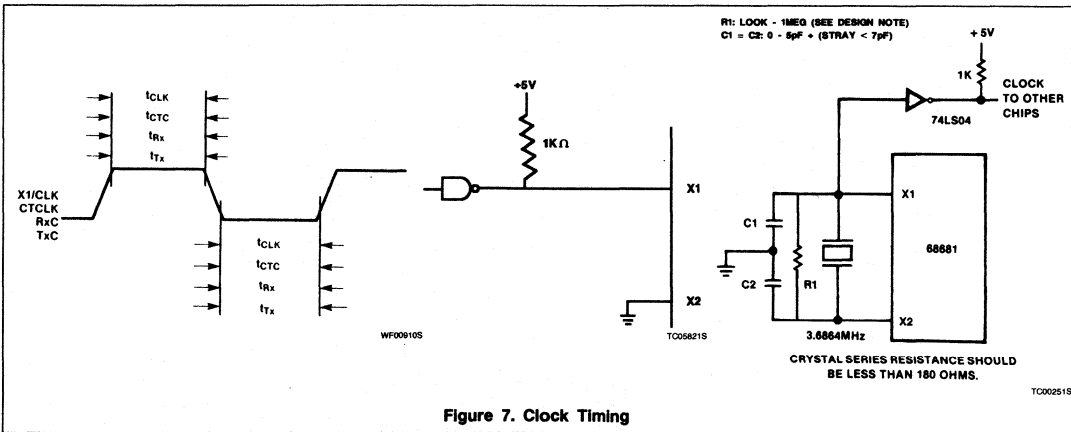
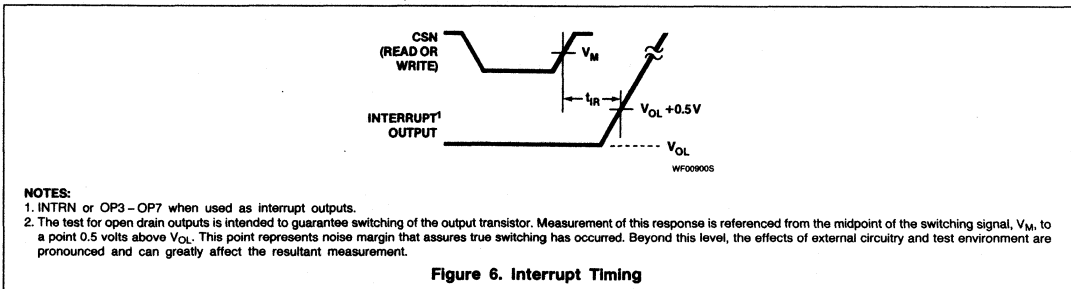
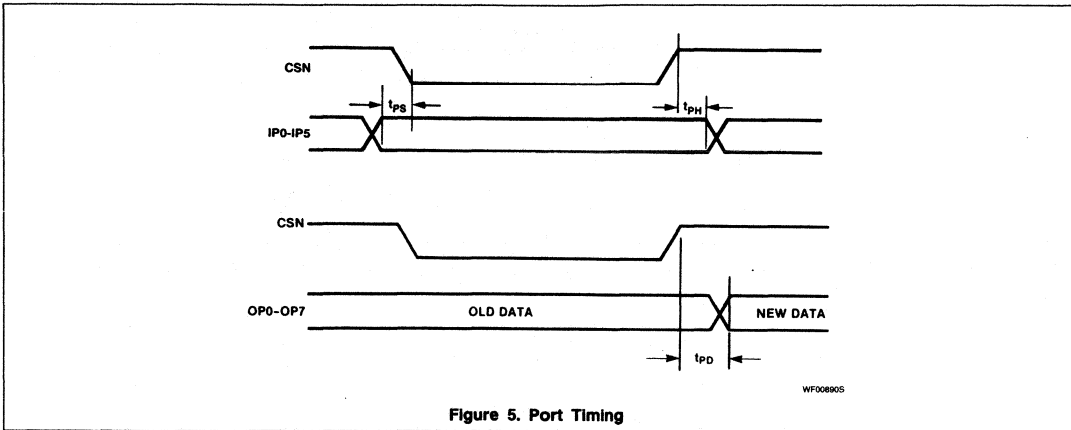

# Dual Asynchronous Receiver/Transmitter (DUART)

SCN68681

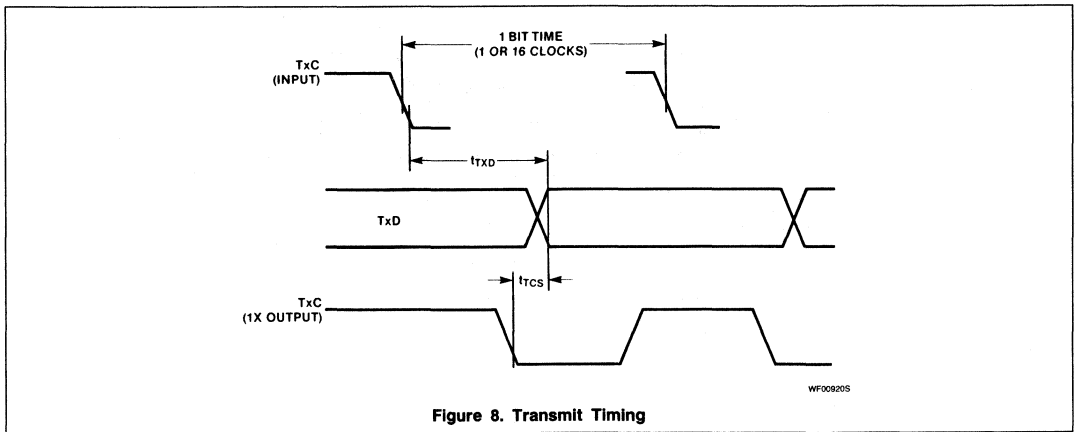

Figure 8. Transmit Timing

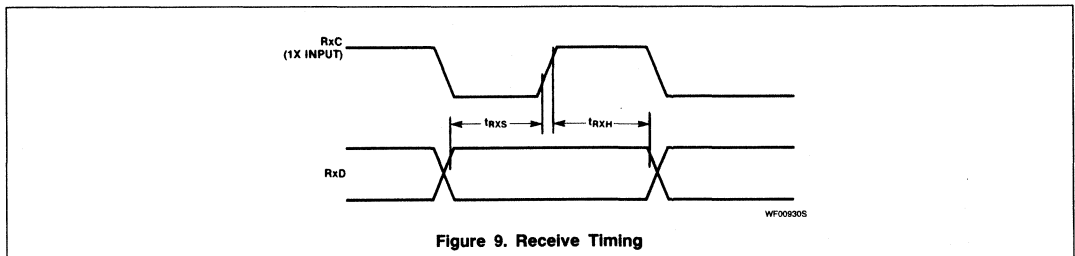
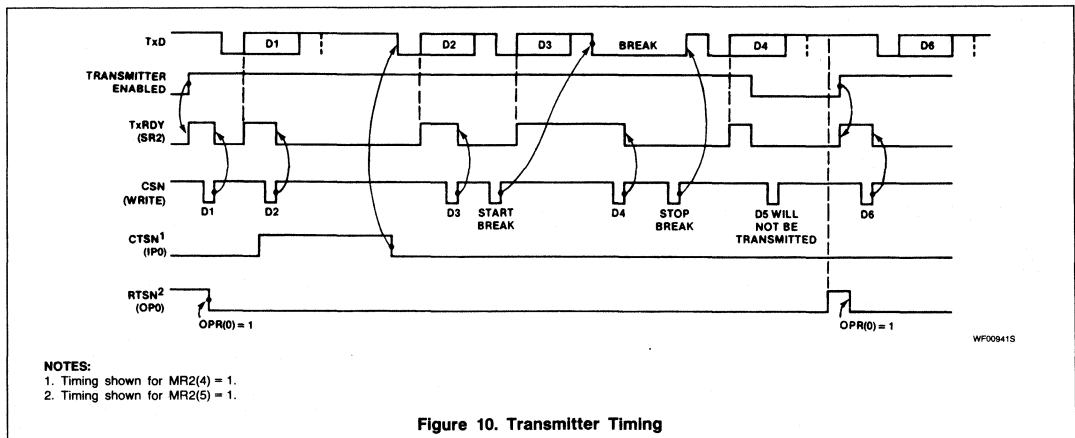

Figure 9. Receive Timing



**NOTES:**

1. Timing shown for MR2(4) = 1.
2. Timing shown for MR2(5) = 1.

Figure 10. Transmitter Timing

# Dual Asynchronous Receiver/Transmitter (DUART)

SCN68684

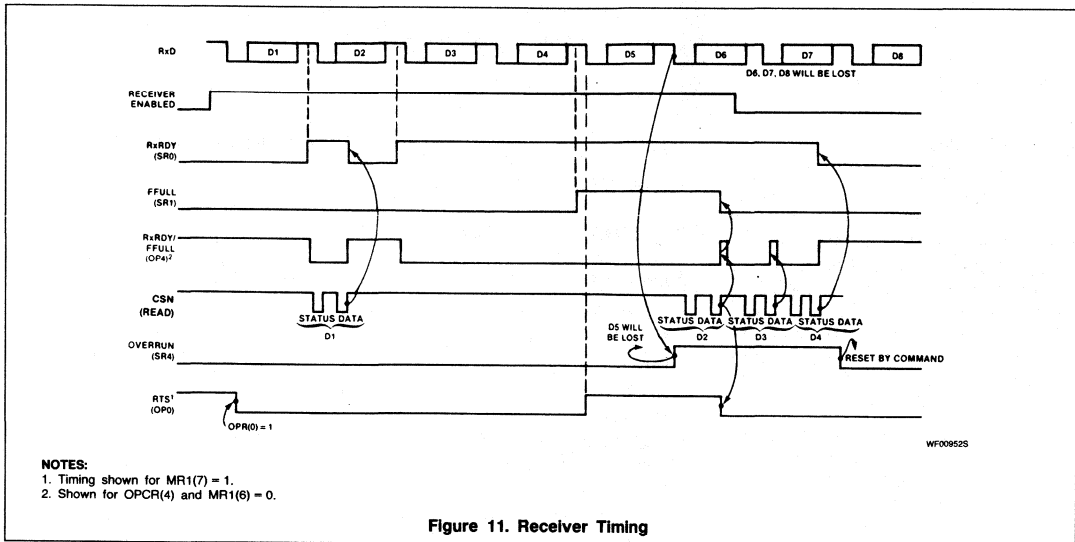

Figure 11. Receiver Timing

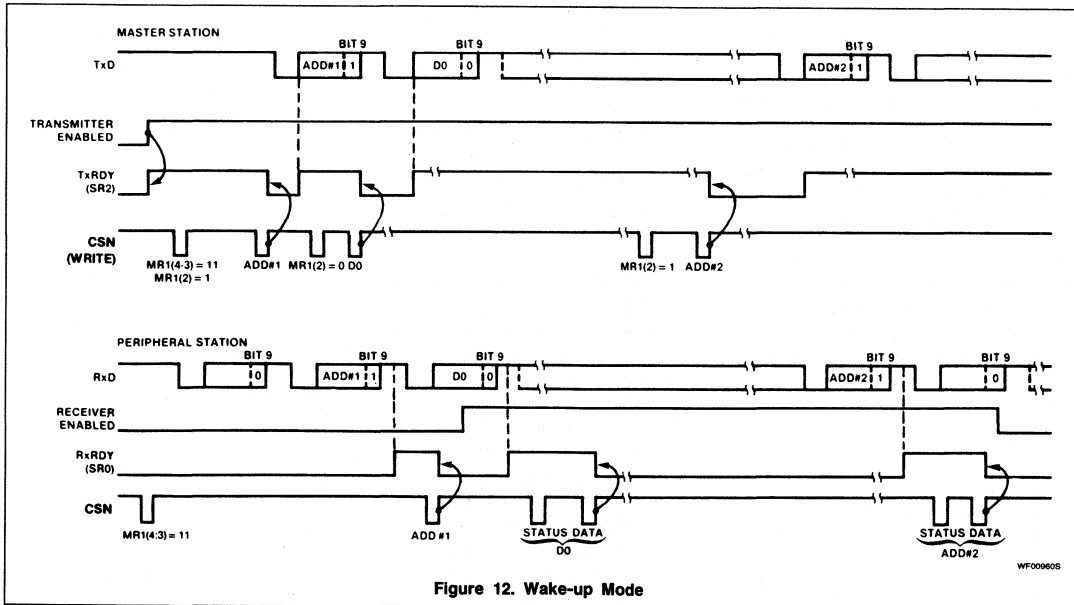

Figure 12. Wake-up Mode

# SCC68692

## Dual Asynchronous Receiver/Transmitter (DUART)

Preliminary Specification

### Microprocessor Products

#### DESCRIPTION

The Signetics SCC68692 Dual Universal Asynchronous Receiver/Transmitter (DUART) is a single-chip CMOS-LSI communications device that provides two independent full-duplex asynchronous receiver/transmitter channels in a single package. It is compatible with other S68000 family devices, and can also interface easily with other microprocessors. The DUART can be used in polled or interrupt driven systems.

The operating mode and data format of each channel can be programmed independently. Additionally, each receiver and transmitter can select its operating speed as one of eighteen fixed baud rates, a  $16\times$  clock derived from a programmable counter/timer, or an external  $1\times$  or  $16\times$  clock. The baud rate generator and counter/timer can operate directly from a crystal or from external clock inputs. The ability to independently program the operating speed of the receiver and transmitter make the DUART particularly attractive for dual-speed channel applications such as clustered terminal systems.

#### FEATURES

- S68000 bus compatible
- Dual full-duplex asynchronous receiver/transmitter
- Quadruple buffered receiver data registers
- Programmable data format
  - 5 to 8 data bits plus parity
  - Odd, even, no parity or force parity
  - 1, 1.5 or 2 stop bits programmable in  $\frac{1}{16}$ -bit increments
- Programmable baud rate for each receiver and transmitter selectable from:
  - 18 fixed rates: 50 to 38.4k baud
  - One user-defined rate derived from programmable timer/counter

- External  $1\times$  or  $16\times$  clock
- Parity, framing, and overrun error detection
- False start bit detection
- Line break detection and generation
- Programmable channel mode
  - Normal (full-duplex)
  - Automatic echo
  - Local loopback
  - Remote loopback
- Multi-function programmable 16-bit counter/timer
- Multi-function 6-bit input port
  - Can serve as clock or control inputs
  - Change-of-state detection on four inputs
- Multi-function 8-bit output port
  - Individual bit set/reset capability
  - Outputs can be programmed to be status/interrupt signals
- Versatile interrupt system
  - Single interrupt output with eight maskable interrupting conditions
  - Interrupt vector output on interrupt acknowledgment
  - Output port can be configured to provide a total of up to six separate wire-ORable interrupt outputs
- Maximum data transfer:  $1\times$  - 1MB/sec,  $16\times$  - 125kB/sec
- Automatic wake-up mode for multidrop applications
- Start-end break interrupt/status
- Detects break which originates in the middle of a character
- On-chip crystal oscillator
- TTL compatible
- Single +5V power supply
- Power down mode
- Receiver timeout mode

#### PIN CONFIGURATIONS

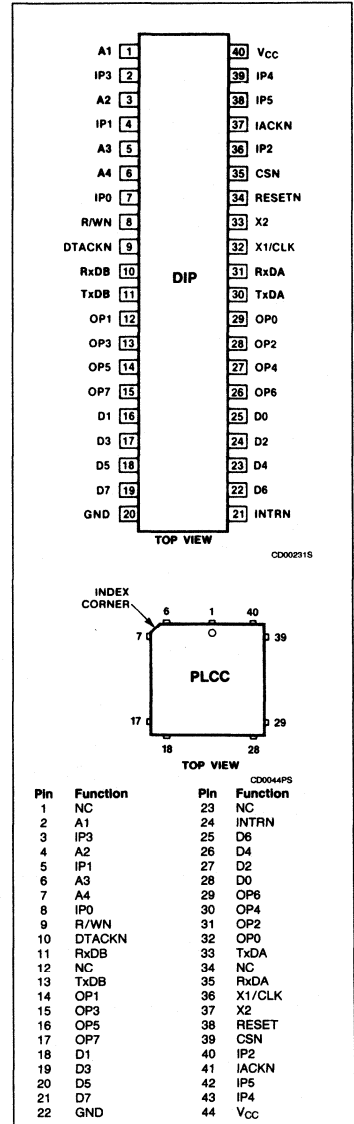

# Dual Asynchronous Receiver/Transmitter (DUART)

## SCC68692

### ORDERING INFORMATION

PACKAGES	V <sub>CC</sub> = +5V ± 5%, T <sub>A</sub> = 0°C to +70°C
Ceramic DIP	SCC68692C1140
Plastic DIP	SCC68692C1N40
Plastic LCC	SCC68692CIA44

### BLOCK DIAGRAM

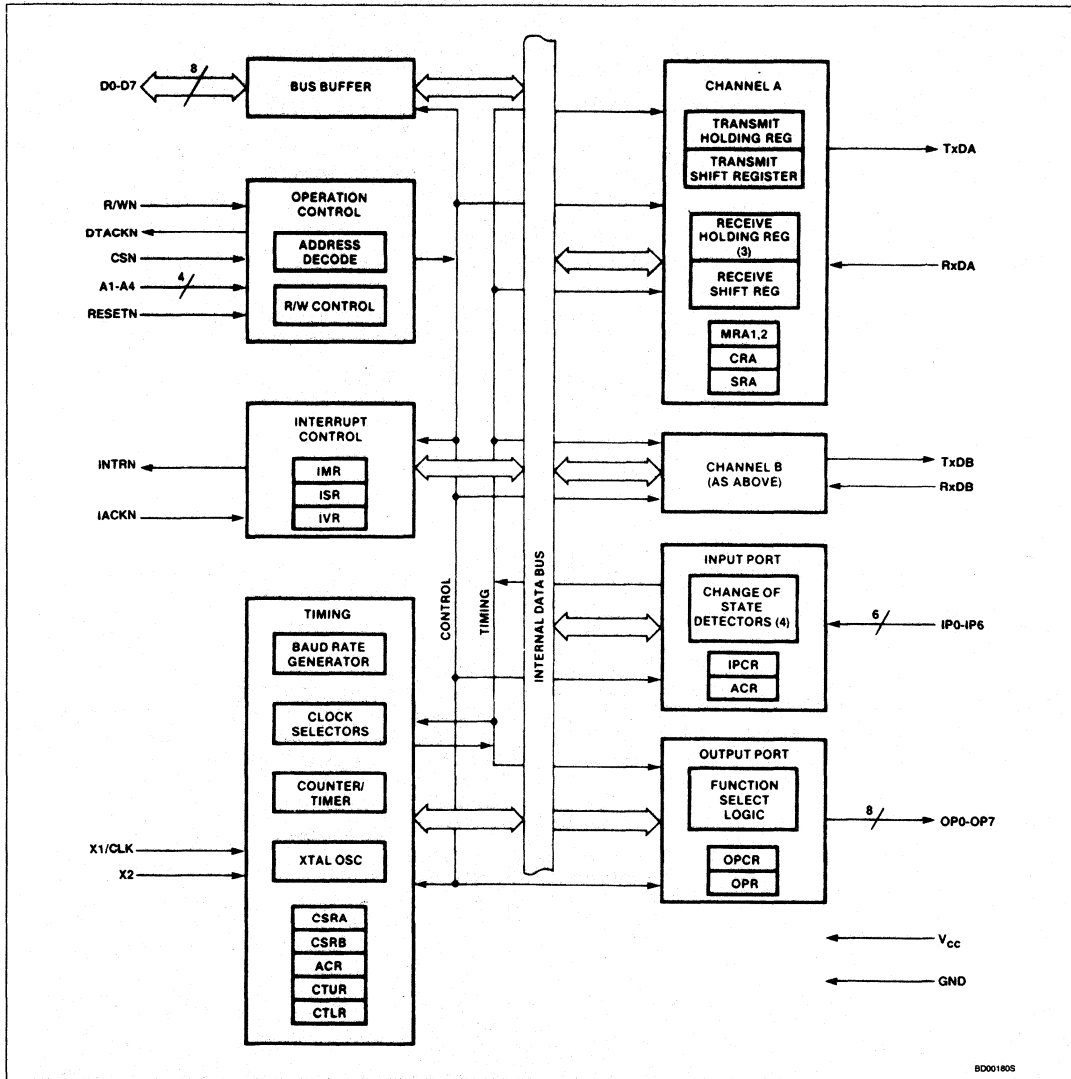

BD001805

## Dual Asynchronous Receiver/Transmitter (DUART)

SCC68692

## PIN DESCRIPTION

MNEMONIC	PIN NO.		TYPE	NAME AND FUNCTION
	DIP	PLCC		
D0 – D7	25, 16, 24 17, 23, 18 22, 19	28, 18, 27 19, 26, 20 25, 21	I/O	<b>Data Bus:</b> Bidirectional 3-State data bus used to transfer commands, data and status between the DUART and the CPU. D0 is the least significant bit.
CSN	35	39	I	<b>Chip Select:</b> Active low input signal. When low, data transfers between the CPU and the DUART are enabled on D0 – D7 as controlled by the R/WN and A1 – A4 inputs. When high, places the D0 – D7 lines in the 3-State condition.
R/WN	8	9	I	<b>Read/Write:</b> A high input indicates a read cycle and a low input indicates a write cycle, when a cycle is initiated by assertion of the CSN input.
A1 – A4	1, 2, 5, 6	2, 4, 6, 7	I	<b>Address Inputs:</b> Select the DUART internal registers and ports for read/write operations.
RESETN	34	38	I	<b>Reset:</b> A low clears internal registers (SRA, SRB, IMR, ISR, OPR, OPCR), initializes the IVR to hex 0F, puts OP0 – OP7 in the high state, stops the counter/timer, and puts channel A and B in the inactive state, with the TxDA and TxDB outputs in the mark (high) state.
DTACKN	9	10	O	<b>Data Transfer Acknowledge:</b> 3-State active low output asserted in write, read, or interrupt cycles to indicate proper transfer of data between the CPU and the DUART.
INTRN	21	24	O	<b>Interrupt Request:</b> Active low, open drain output which signals the CPU that one or more of the eight maskable interrupting conditions are true.
IACKN	37	41	I	<b>Interrupt Acknowledge:</b> Active low input indicating an interrupt acknowledge cycle. In response, the DUART will place the interrupt vector on the data bus and will assert DTACKN if it has an interrupt pending.
X1/CLK	32	36	I	<b>Crystal 1:</b> Crystal or external clock input. A crystal or clock of the specified limits must be supplied at all times. If a crystal is used, a capacitor must be connected from this pin to ground (see Figure 7).
X2	33	37	I	<b>Crystal 2:</b> Connection for other side of the crystal. If a crystal is used, a capacitor must be connected from this pin to ground (see Figure 7). If X1/CLK is driven from an external source, this pin must be open.
RxDA	31	35	I	<b>Channel A Receiver Serial Data Input:</b> The least significant bit is received first. "Mark" is high, "space" is low.
RxDB	10	11	I	<b>Channel B Receiver Serial Data Input:</b> The least significant bit is received first. "Mark" is high, "space" is low.
TxDA	30	33	O	<b>Channel A Transmitter Serial Data Output:</b> The least significant bit is transmitted first. This output is held in the "mark" condition when the transmitter is disabled, idle, or when operating in local loopback mode. "Mark" is high, "space" is low.
TxDB	11	13	O	<b>Channel B Transmitter Serial Data Output:</b> The least significant bit is transmitted first. This output is held in the "mark" condition when the transmitter is disabled, idle, or when operating in local loopback mode. "Mark" is high, "space" is low.
OP0	29	32	O	<b>Output 0:</b> General purpose output, or channel A request to send (RTSAN, active low); can be deactivated automatically on receive or transmit.
OP1	12	14	O	<b>Output 1:</b> General purpose output, or channel B request to send (RTSBN, active low); can be deactivated automatically on receive or transmit.
OP2	28	40	O	<b>Output 2:</b> General purpose output, or channel A transmitter 1× or 16× clock output, or channel A receiver 1× clock output.
OP3	13	15	O	<b>Output 3:</b> General purpose output, or open drain, active low counter/timer output, or channel B transmitter 1× clock output, or channel B receiver 1× clock output.
OP4	27	30	O	<b>Output 4:</b> General purpose output, or channel A open drain, active low, RxRDYA/FFULLA output.
OP5	14	16	O	<b>Output 5:</b> General purpose output or channel B open drain, active low, RxRDYB/FFULLB output.
OP6	26	29	O	<b>Output 6:</b> General purpose output, or channel A open drain, active low, TxRDYA output.
OP7	15	17	O	<b>Output 7:</b> General purpose output, or channel B open drains, active low, TxRDYB output.
IP0	7	8	I	<b>Input 0:</b> General purpose input, or channel A clear to send active low input (CTSAN).

## Dual Asynchronous Receiver/Transmitter (DUART)

SCC68692

## PIN DESCRIPTION (Continued)

MNEMONIC	PIN NO.		TYPE	NAME AND FUNCTION
	DIP	PLCC		
IP1	4	5	I	<b>Input 1:</b> General purpose input, or channel B clear to send active low input (CTSBN).
IP2	36	40	I	<b>Input 2:</b> General purpose input, or channel B receiver external clock input (RxCB), or counter/timer external clock input. When the external clock is used by the receiver, the received data is sampled on the rising edge of the clock.
IP3	2	3	I	<b>Input 3:</b> General purpose input, or channel A transmitter external clock input (TxCA). When the external clock is used by the transmitter, the transmitted data is clocked on the falling edge of the clock.
IP4	39	43	I	<b>Input 4:</b> General purpose input, or channel A receiver external clock input (RxCA). When the external clock is used by the receiver, the received data is sampled on the rising edge of the clock.
IP5	38	42	I	<b>Input 5:</b> General purpose input, or channel B transmitter external clock input (TxCB). When the external clock is used by the transmitter, the transmitted data is clocked on the falling edge of the clock.
V <sub>CC</sub>	40	44	I	<b>Power Supply:</b> +5V supply input.
GND	20	22	I	<b>Ground</b>

Each receiver is quadruply buffered to minimize the potential of receiver overrun or to reduce interrupt overhead in interrupt driven systems. In addition, a flow control capability is provided to disable a remote DUART transmitter when the buffer of the receiving device is full.

Also provided on the SCC68681 are a multipurpose 6-bit input port and a multipurpose 8-bit output port. These can be used as general purpose I/O ports or can be assigned specific functions (such as clock inputs or status/interrupt outputs) under program control.

### BLOCK DIAGRAM

The SCC68692 DUART consists of the following eight major sections: data bus buffer, operation control, interrupt control, timing, communications channels A and B, input port and output port. Refer to the block diagram.

### Data Bus Buffer

The data bus buffer provides the interface between the external and internal data buses. It is controlled by the operation control block to allow read and write operations to take place between the controlling CPU and the DUART.

### Operation Control

The operation control logic receives operation commands from the CPU and generates appropriate signals to internal sections to control device operation. It contains address decoding and read and write circuits to permit communications with the microprocessor via the data bus buffer. The DTACKN output is asserted during write and read cycles to indicate to the CPU that data has been

latched on a write cycle, or that valid data is present on the bus on a read cycle.

### Interrupt Control

A single active low interrupt output (INTRN) is provided which is activated upon the occurrence of any of eight internal events. Associated with the interrupt system are the interrupt mask register (IMR), the interrupt status register (SR), the auxiliary control register (ACR), and the interrupt vector register (IVR). The IMR may be programmed to select only certain conditions to cause INTRN to be asserted. The ISR can be read by the CPU to determine all currently active interrupting conditions. When IACKN is asserted, and the DUART has an interrupt pending, the DUART responds by placing the contents of the IVR register on the data bus and asserting DTACKN.

Outputs OP3 – OP7 can be programmed to provide discrete interrupt outputs for the transmitters, receivers, and counter/timer.

### Timing Circuits

The timing block consists of a crystal oscillator, a baud rate generator, a programmable 16-bit counter/timer, and four clock selectors. The crystal oscillator operates directly from a 3.6864MHz crystal connected across the X1/CLK and X2 inputs. If an external clock of the appropriate frequency is available, it may be connected to X1/CLK. The clock serves as the basic timing reference for the baud rate generator (BRG), the counter/timer and other internal circuits. A clock signal within the limits specified in the specifications section of this data sheet must always be supplied to the DUART. If an external signal is used instead of a crystal, X1 should be driven using a configuration similar to the one in Figure 7.

The baud rate generator operates from the oscillator or external clock input and is capable of generating 18 commonly used data communications baud rates ranging from 50 to 38.4k baud. The clock outputs from the BRG are at 16× the actual baud rate. The counter/timer can be used as a timer to produce a 16× clock for any other baud rate by counting down the crystal clock or an external clock. The four clock selectors allow the independent selection, for each receiver and transmitter, of any of these baud rates or an external timing signal.

The counter/timer (C/T) can be programmed to use one of several timing sources as its input. The output of the C/T is available to the clock selectors and can also be programmed to be output at OP3. In the counter mode, the contents of the C/T can be read by the CPU and it can be stopped and started under program control. In the timer mode, the C/T acts as a programmable divider.

### Communications Channels A and B

Each communications channel of the SCC68692 comprises a full-duplex asynchronous receiver/transmitter (DUART). The operating frequency for each receiver and transmitter can be selected independently from the baud rate generator, the counter timer, or from an external input.

The transmitter accepts parallel data from the CPU, converts it to a serial bit stream, inserts the appropriate start, stop, and optional parity bits and outputs a composite serial stream of data on the TxD output pin. The receiver accepts serial data on the RxD pin, converts this serial input to parallel format, checks for start bit, stop bit, parity bit (if any), or break

# Dual Asynchronous Receiver/Transmitter (DUART)

SCC68692

condition and sends an assembled character to the CPU.

## Input Port

The input port pulse detection circuitry uses a 38.4kHz sampling clock derived from one of the baud rate generator taps. This results in a sampling period of slightly more than 25 $\mu$ s (assuming that the clock input is 3.6864MHz). The detection circuitry, in order to guarantee a true change in level has occurred, requires that two successive samples at the new logic level be observed. As a consequence, the minimum duration of the signal change is 25 $\mu$ s if the transition occurs coincident with the first sample pulse. The 50 $\mu$ s time refers to the situation in which the change of state is just missed and the first change of state is not detected until 25 $\mu$ s later.

The inputs to this unlatched 6-bit port can be read by the CPU by performing a read operation at address D16. A high input results in a logic 1 while a low input results in a logic 0. D7 will always be read as a logic 1 and D6 will reflect the level of IACKN. The pins of this port can also serve as auxiliary inputs to certain portions of the DUART logic.

Four change-of-state detectors are provided which are associated with inputs IP3, IP2, IP1, and IP0. A high-to-low or low-to-high transition of these inputs lasting longer than 25–50 $\mu$ s will set the corresponding bit in the input port change register. The bits are cleared when the register is read by the CPU. Any change of state can also be programmed to generate an interrupt to the CPU.

## Output Port

The 8-bit multi-purpose output port can be used as a general purpose output port, in which case the outputs are the complements of the output port register (OPR). OPR[n] = 1 results in OP[n] = low and vice-versa. Bits of the OPR can be individually set and reset. A bit is set by performing a write operation at address E<sub>16</sub> with the accompanying data specifying the bits to be set (1 = set, 0 = no change). Likewise, a bit is reset by a write at address F<sub>16</sub> with the accompanying data specifying the bits to be reset (1 = reset, 0 = no change).

Outputs can be also individually assigned specific functions by appropriate programming of the channel A mode registers (MR1A, MR2A), the channel B mode registers (MR1B, MR2B), and the output port configuration register (OPCR).

## OPERATION

### Transmitter

The SCC68692 is conditioned to transmit data when the transmitter is enabled through the command register. The SCC68692 indi-

cates to the CPU that it is ready to accept a character by setting the TxRDY bit in the status register. This condition can be programmed to generate an interrupt request at OP6 or OP7 and INTRN. When a character is loaded into the transmit holding register (THR), the above conditions are negated. Data is transferred from the holding register to the transmit shift register when it is idle or has completed transmission of the previous character. The TxRDY conditions are then asserted again which means one full character time of buffering is provided. Characters cannot be loaded into the THR while the transmitter is disabled.

The transmitter converts the parallel data from the CPU to a serial bit stream on the TxD output pin. It automatically sends a start bit followed by the programmed number of data bits, an optional parity bit, and the programmed number of stop bits. The least significant bit is sent first. Following the transmission of the stop bits, if a new character is not available in the THR, the TxD output remains high and the TxEMT bit in the status register (SR) will be set to 1. Transmission resumes and the TxEMT bit is cleared when the CPU loads a new character into the THR. If the transmitter is disabled, it continues operating until the character currently being transmitted is completely sent out. The transmitter can be forced to send a continuous low condition by issuing a send break command.

The transmitter can be reset through a software command. If it is reset, operation ceases immediately and the transmitter must be enabled through the command register before resuming operation. If CTS operation is enabled, the CTSN input must be low in order for the character to be transmitted, if it goes high in the middle of a transmission, the character in the shift register is transmitted and TxDA then remains in the marking state until CTSN goes low. The transmitter can also control the deactivation of the RTSN output. If programmed, the RTSN output will be reset one bit time after the character in the transmit shift register and transmit holding register (if any) are completely transmitted; only if the transmitter has been disabled.

### Receiver

The SCC68692 is conditioned to receive data when enabled through the command register. The receiver looks for a high to low (mark to space) transition of the start bit on the RxD input pin. If a transition is detected, the state of the RxD pin is sampled each 16 $\times$  clock for 7 $\frac{1}{2}$  clocks (16 $\times$  clock model) or at the next rising edge of the bit time clock (1 $\times$  clock model). If RxD is sampled high, the start bit is invalid and the search for a valid start bit begins again. If RxD is still low, a valid start bit is assumed and the receiver continues to sample the input at one bit time intervals at

the theoretical center of the bit, until the proper number of data bits and the parity bit (if any) have been assembled, and one stop bit has been detected. The least significant bit is received first. The data is then transferred to the receive holding register (RHR) and the RxRDY bit in the SR is set to a 1. This condition can be programmed to generate an interrupt at OP4 or OP5 and INTRN. If the character length is less than eight bits, the most significant unused bits in the RHR are set to zero.

After the stop bit is detected, the receiver will immediately look for the next start bit. However, if a non-zero character was received without a stop bit (framing error) and RxD remains low for one half of the bit period after the stop bit was sampled, then the receiver operates as if a new start bit transition had been detected at that point (one-half bit time after the stop bit was sampled).

The parity error, framing error, overrun error and received break state (if any) are strobed into the SR at the received character boundary, before the RxRDY status bit is set. If a break condition is detected (RxD is low for the entire character including the stop bit), a character consisting of all zeros will be loaded into the RHR and the received break bit in the SR is set to 1. The RxD input must return to a high condition for at least one-half bit time before a search for the next start bit begins.

The RHR consists of a first-in-first-out (FIFO) stack with a capacity of three characters. Data is loaded from the receive shift register into the topmost empty position of the FIFO. The RxRDY bit in the status register is set whenever one or more characters are available to be read, and a FFULL status bit is set if all three stack positions are filled with data. Either of these bits can be selected to cause an interrupt. A read of the RHR outputs the data at the top of the FIFO. After the read cycle, the data FIFO and its associated status bits (see below) are "popped" thus emptying a FIFO position for new data.

In addition to the data word, three status bits (parity error, framing error, and received break) are also appended to each data character in the FIFO (overrun is not). Status can be provided in two ways, as programmed by the error mode control bit in the mode register. In the "character" mode, status is provided on a character-by-character basis; the status applies only to the character at the top of the FIFO. In the "block" mode, the status provided in the SR for these three bits is the logical-OR of the status for all characters coming to the top of the FIFO since the last "reset error" command was issued. In either mode reading the SR does not affect the FIFO. The FIFO is "popped" only when the



## Dual Asynchronous Receiver/Transmitter (DUART)

SCC68692

Table 1. 68692 Register Addressing

A4	A3	A2	A1	READ (R/WN = 1)	WRITE (R/WN = 0)
0	0	0	0	Mode Register A (MR1A, MR2A)	Mode Register A (MR1A, MR2A)
0	0	0	1	Status Register A (SRA)	Clock Select Reg. A (CSRA)
0	0	1	0	*Reserved*	Command Register A (CRA)
0	0	1	1	Rx Holding Register A (RHRA)	Tx Holding Register A (THRA)
0	1	0	0	Input Port Change Reg. (IPCR)	Aux. Control Register (ACR)
0	1	0	1	Interrupt Status Reg. (ISR)	Interrupt Mask Reg. (IMR)
0	1	1	0	Counter/Timer Upper (CTU)	C/T Upper Register (CTUR)
0	1	1	1	Counter/Timer Lower (CTL)	C/T Lower Register (CTLR)
1	0	0	0	Mode Register B (MR1B, MR2B)	Mode Register B (MR1B, MR2B)
1	0	0	1	Status Register B (SRB)	Clock Select Reg. B (CSRB)
1	0	1	0	*Reserved*	Command Register B (CRB)
1	0	1	1	Rx Holding Register B (RHRB)	Tx Holding Register B (THRB)
1	1	0	0	Interrupt Vector Reg. (IVR)	Interrupt Vector Reg. (IVR)
1	1	0	1	Input Port	Output Port Conf. Reg. (OPCR)
1	1	1	0	Start Counter Command	Set Output Port Bits Command
1	1	1	1	Stop Counter Command	Reset Output Port Bits Command

RHR is read. Therefore the status register should be read prior to reading the FIFO.

If the FIFO is full when a new character is received, that character is held in the receive shift register until a FIFO position is available. If an additional character is received while this state exists, the contents of the FIFO are not affected: the character previously in the shift register is lost and the overrun error status bit (SP[4]) will be set upon receipt of the start bit of the new (overrunning) character.

The receiver can control the deactivation of RTS. If programmed to operate in this mode, the RTSN output will be negated when a valid start bit was received and the FIFO is full. When a FIFO position becomes available, the RTSN output will be re-asserted automatically. This feature can be used to prevent an overrun, in the receiver, by connecting the RTSN output to the CTSN input of the transmitting device.

If the receiver is disabled, the FIFO characters can be read. However, no additional characters can be received until the receiver is enabled again. If the receiver is reset, the FIFO and all of the receiver status, and the corresponding output ports and interrupt are reset. No additional characters can be received until the receiver is enabled again.

### Timeout Mode

Under certain conditions, the user may want to set the receiver to interrupt the CPU when the receive FIFO becomes full. This can be accomplished by programming MR1[6] = 1. If a message that is only one or two characters long is received, the FIFO is not full so that ISR[1] does not set and the CPU is not interrupted. The CPU will not know that there is data in the receive FIFO. The time-out mode provides the user with a time-out interrupt via the C/T. If a character is received and the FIFO does not become full, a pre-select-

ed period of delay can be timed out by the C/T and the CPU interrupted.

This mode is enabled by writing the appropriate command to the command register. Writing an "AX" to CRA or CRB will invoke the time-out mode for that channel. Writing a "CX" to CRA or CRB will reset the time-out mode. CTU and CTL must be loaded with a value greater than the normal receive character period. Each time a received character is transferred from the shift register to the RHR, the C/T is reloaded with the value in CTU and CTL and then restarted. If the C/T is allowed to end the count, the counter ready bit (ISR[3]) will be set. If IMR[3] is set, an interrupt will occur.

### Multidrop Mode

The DUART is equipped with a wake up mode used for multidrop applications. This mode is selected by programming bits MR1A[4:3] or MR1B[4:3] to "11" for channels A and B respectively. In this mode of operation, a "master" station transmits an address character followed by data characters for the addressed "slave" station. The slave stations, with receivers that are normally disabled, examine the received data stream and "wake-up" the CPU (by setting RxRDY) only upon receipt of an address character. The CPU compares the received address to its station address and enables the receiver if it wishes to receive the subsequent data characters. Upon receipt of another address character, the CPU may disable the receiver to initiate the process again.

A transmitted character consists of a start bit, the programmed number of data bits, an address/data (A/D) bit, and the programmed number of stop bits. The polarity of the transmitted A/D bit is selected by the CPU by programming bit MR1A[2]/MR1B[2]. MR1A[2]/MR1B[2] = 0 transmits a zero in the A/D bit position, which identifies the corresponding data bits as data, while

MR1A[2]/MR1B[2] = 1 transmits a one in the A/D bit position, which identifies the corresponding data bits as an address. The CPU should program in the mode register prior to loading the corresponding data bits into the THR.

In this mode, the receiver continuously looks at the received data stream, whether it is enabled or disabled. If disabled, it sets the RxRDY status bit and loads the character into the RHR FIFO if the received A/D bit is a one (address tag), but discards the received character if the received A/D bit is a zero (data tag). If enabled, all received characters are transferred to the CPU via the RHR. In either case, the data bits are loaded into the data FIFO while the A/D bit is loaded into the status FIFO position normally used for parity error (SRA[5] or SRB[5]). Framing error, overrun error, and break detect operate normally whether or not the receiver is enabled.

### PROGRAMMING

The operation of the DUART is programmed by writing control words into the appropriate registers. Operational feedback is provided via status registers which can be read by the CPU. The addressing of the registers is described in Table 1.

The contents of certain control registers are initialized to zero on RESET. Care should be exercised if the contents of a register are changed during operation, since certain changes may cause operational problems. For example, changing the number of bits per character while the transmitter is active may cause the transmission of an incorrect character. In general, the contents of the MR, the CSR, and the OPCR should only be changed while the receiver(s) and transmitter(s) are not enabled, and certain changes to the ACR should only be made while the C/T is stopped.

Mode registers 1 and 2 of each channel are accessed via independent auxiliary pointers. The pointer is set to MR1x by RESET or by issuing a "reset pointer" command via the corresponding command register. Any read or write of the mode register while the pointer is at MR1x switches the pointer to MR2x. The pointer then remains at MR2x, so that subsequent accesses are always to MR2x unless the pointer is reset to MR1x as described above.

Mode, command, clock select, and status registers are duplicated for each channel to provide total independent operation and control. Refer to Table 2 for register bit descriptions. The reserved registers at addresses H'02' and H'0A' should never be read during normal operation since they are reserved for internal diagnostics.

# Dual Asynchronous Receiver/Transmitter (DUART)

SCC68692

**Table 2. Register Bit Formats**

	BIT 7	BIT 6	BIT 5	BIT 4	BIT 3	BIT 2	BIT 1	BIT 0
	<b>RxRTS CONTROL</b>	<b>RxINT SELECT</b>	<b>ERROR MODE</b>	<b>PARITY MODE</b>		<b>PARITY TYPE</b>	<b>BITS PER CHARACTER</b>	
<b>MR1A</b> <b>MR1B</b>	0=no 1=yes	0=RxDY 1=FFULL	0=char 1=block	00 = with parity 01 = force parity 10 = no parity 11 = multi-drop mode		0=even 1=odd	00=5 01=6 10=7 11=8	

	BIT 7	BIT 6	BIT 5	BIT 4	BIT 3	BIT 2	BIT 1	BIT 0
	<b>CHANNEL MODE</b>		<b>TxRTS CONTROL</b>	<b>CTS ENABLE Tx</b>	<b>STOP BIT LENGTH<sup>*</sup></b>			
<b>MR2A</b> <b>MR2B</b>	00=Normal 01=Auto echo 10=Local loop 11=Remote loop		0=no 1=yes	0=no 1=yes	0=0.563 1=0.625 2=0.688 3=0.750	4=0.813 5=0.875 6=0.938 7=1.000	8=1.563 9=1.625 A=1.688 B=1.750	C=1.813 D=1.875 E=1.938 F=2.000

**NOTE:**

<sup>\*</sup>Add 0.5 to values shown for 0-7 if channel is programmed for 5 bits/char.

	BIT 7	BIT 6	BIT 5	BIT 4	BIT 3	BIT 2	BIT 1	BIT 0
	<b>RECEIVER CLOCK SELECT</b>				<b>TRANSMITTER CLOCK SELECT</b>			
<b>CSRA</b> <b>CSRB</b>	See Text				See Text			

	BIT 7	BIT 6	BIT 5	BIT 4	BIT 3	BIT 2	BIT 1	BIT 0
	<b>MISCELLANEOUS COMMANDS</b>				<b>DISABLE Tx</b>	<b>ENABLE Tx</b>	<b>DISABLE Rx</b>	<b>ENABLE Rx</b>
<b>CRA</b> <b>CRB</b>	See Text				0=no 1=yes	0=no 1=yes	0=no 1=yes	0=no 1=yes

	BIT 7	BIT 6	BIT 5	BIT 4	BIT 3	BIT 2	BIT 1	BIT 0
	<b>RECEIVED BREAK</b>	<b>FRAMING ERROR</b>	<b>PARITY ERROR</b>	<b>OVERRRUN ERROR</b>	<b>TxE<sub>MT</sub></b>	<b>TxRDY</b>	<b>FFULL</b>	<b>RxDY</b>
<b>SRA</b> <b>SRB</b>	0=no 1=yes	0=no 1=yes	0=no 1=yes	0=no 1=yes	0=no 1=yes	0=no 1=yes	0=no 1=yes	0=no 1=yes

**NOTE:**

<sup>\*</sup>These status bits are appended to the corresponding data character in the receive FIFO. A read of the status register provides these bits (7:5) from the top of the FIFO together with bits 4:0. These bits are cleared by a "reset error status" command. In character mode they are discarded when the corresponding data character is read from the FIFO.

	BIT 7	BIT 6	BIT 5	BIT 4	BIT 3	BIT 2	BIT 1	BIT 0
	<b>OP7</b>	<b>OP6</b>	<b>OP5</b>	<b>OP4</b>	<b>OP3</b>		<b>OP2</b>	
<b>OPCR</b>	0 = OPR[7] 1 = TxRDYB	0 = OPR[6] 1 = TxRDYA	0 = OPR[5] 1 = RxRDY/ FFULLB	0 = OPR[4] 1 = RxRDY/ FFULLA	00 = OPR[3] 01 = C/T OUTPUT 10 = TxCB(1 × ) 11 = RxCB(1 × )		00 = OPR[2] 01 = TxCA(16 × ) 10 = TxCA(1 × ) 11 = RxCA(1 × )	

	BIT 7	BIT 6	BIT 5	BIT 4	BIT 3	BIT 2	BIT 1	BIT 0
	<b>BRG SET SELECT</b>	<b>COUNTER/TIMER MODE AND SOURCE</b>			<b>DELTA IP3 INT</b>	<b>DELTA IP2 INT</b>	<b>DELTA IP1 INT</b>	<b>DELTA IP0 INT</b>
<b>ACR</b>	0 = set1 1 = set2	See Table 4			0 = off 1 = on	0 = off 1 = on	0 = off 1 = on	0 = off 1 = on

# Dual Asynchronous Receiver/Transmitter (DUART)

SCC68692

**Table 2. Register Bit Formats (Continued)**

	BIT 7	BIT 6	BIT 5	BIT 4	BIT 3	BIT 2	BIT 1	BIT 0
	ΔIP3	ΔIP2	ΔIP1	ΔIP0	IP3	IP2	IP1	IP0
IPCR	0 = no 1 = yes	0 = no 1 = yes	0 = no 1 = yes	0 = no 1 = yes	0 = low 1 = high	0 = low 1 = high	0 = low 1 = high	0 = low 1 = high

	BIT 7	BIT 6	BIT 5	BIT 4	BIT 3	BIT 2	BIT 1	BIT 0
	INPUT PORT CHANGE	Δ BREAK B	RxRDY/FFULLB	TxRDYB	COUNTER READY	Δ BREAK A	RxRDY/FFULLA	TxRDYA
ISR	0=no 1=yes	0=no 1=yes	0=no 1=yes	0=no 1=yes	0=no 1=yes	0=no 1=yes	0=no 1=yes	0=no 1=yes

	BIT 7	BIT 6	BIT 5	BIT 4	BIT 3	BIT 2	BIT 1	BIT 0
	IN. PORT CHANGE INT	Δ BREAK B INT	RxRDY/FFULLB INT	TxRDYB INT	COUNTER READY INT	Δ BREAK A INT	RxRDY/FFULLA INT	TxRDYA INT
IMR	0=off 1=on	0=off 1=on	0=off 1=on	0=off 1=on	0=off 1=on	0=off 1=on	0=off 1=on	0=off 1=on

	BIT 7	BIT 6	BIT 5	BIT 4	BIT 3	BIT 2	BIT 1	BIT 0
	C/T[15]	C/T[14]	C/T[13]	C/T[12]	C/T[11]	C/T[10]	C/T[9]	C/T[8]
CTUR								

	BIT 7	BIT 6	BIT 5	BIT 4	BIT 3	BIT 2	BIT 1	BIT 0
	C/T[7]	C/T[6]	C/T[5]	C/T[4]	C/T[3]	C/T[2]	C/T[1]	C/T[0]
CTLR								

	BIT 7	BIT 6	BIT 5	BIT 4	BIT 3	BIT 2	BIT 1	BIT 0
	IVR[7]	IVR[6]	IVR[5]	IVR[4]	IVR[3]	IVR[2]	IVR[1]	IVR[0]
IVR								

**MR1A — Channel A Mode Register 1**

MR1A is accessed when the channel A MR pointer points to MR1. The pointer is set to MR1 by RESET or by a "set pointer" command applied via CRA. After reading or writing MR1A, the pointer will point to MR2A.

**MR1A[7] — Channel A Receiver Request-to-Send Control**

This bit controls the deactivation of the RTSAN output (OP0) by the receiver. This output is normally asserted by setting OPR[0] and negated by resetting OPR[0].

MR1A[7] = 1 causes RTSAN to be negated upon receipt of a valid start bit if the channel A FIFO is full. However, OPR[0] is not reset and RTSAN will be asserted again when an empty FIFO position is available. This feature can be used for flow control to prevent

overrun in the receiver by using the RTSAN output signal to control the CTSN input of the transmitting device.

**MR1A[6] — Channel A Receiver Interrupt Select**

This bit selects either the channel A receiver ready status (RxRDY) or the channel A FIFO full status (FFULL) to be used for CPU interrupts. It also causes the selected bit to be output on OP4 if it is programmed as an interrupt output via the OPCR.

**MR1A[5] — Channel A Error Mode Select**

This bit selects the operating mode of the three FIFOed status bits (FE, PE, received break) for channel A. In the "character" mode, status is provided on a character-by-character basis: the status applies only to the character at the top of the FIFO. In the

"block" mode, the status provided in the SR for these bits is the accumulation (logical-OR) of the status for all characters coming to the top of the FIFO since the last "reset error" command for channel A was issued.

**MR1A[4:3] — Channel A Parity Mode Select**

If "with parity" or "force parity" is selected, a parity bit is added to the transmitted character and the receiver performs a parity check on incoming data. MR1A[4:3] = 11 selects channel A to operate in the special multidrop mode described in the Operation section.

**MR1A[2] — Channel A Parity Type Select**

This bit selects the parity type (odd or even) if the "with parity" mode is programmed by MR1A[4:3], and the polarity of the forced parity bit if the "force parity" mode is pro-

## Dual Asynchronous Receiver/Transmitter (DUART)

SCC68692

grammed. It has no effect if the "no parity" mode is programmed. In the special multidrop mode it selects the polarity of the A/D bit.

#### MR1A[1:0] — Channel A Bits per Character Select

This field selects the number of data bits per character to be transmitted and received. The character length does not include the start, parity, and stop bits.

#### MR2A — Channel A Mode Register 2

MR2A is accessed when the channel A MR pointer points to MR2, which occurs after any access to MR1A. Accesses to MR2A do not change the pointer.

#### MR2A[7:6] — Channel A Mode Select

Each channel of the DUART can operate in one of four modes. MR2A[7:6] = 00 is the normal mode, with the transmitter and receiver operating independently. MR2A[7:6] = 01 places the channel in the automatic echo mode, which automatically retransmits the received data. The following conditions are true while in automatic echo mode:

1. Received data is reclocked and retransmitted on the TxDA output.
2. The receive clock is used for the transmitter.
3. The receiver must be enabled, but the transmitter need not be enabled.
4. The channel A TxRDY and TxEMT status bits are inactive.
5. The received parity is checked, but is not regenerated for transmission, i.e., transmitted parity bit is as received.
6. Character framing is checked, but the stop bits are retransmitted as received.
7. A received break is echoed as received until the next valid start bit is detected.
8. CPU to receiver communication continues normally, but the CPU to transmitter link is disabled.

Two diagnostic modes can also be configured. MR2A[7:6] = 10 selects local loopback mode. In this mode:

1. The transmitter output is internally connected to the receiver input.
2. The transmit clock is used for the receiver.
3. The TxDA output is held high.
4. The RxDA input is ignored.
5. The transmitter must be enabled, but the receiver need not be enabled.
6. CPU to transmitter and receiver communications continue normally.

The second diagnostic mode is the remote loopback mode, selected by MR2A[7:6] = 11. In this mode:

1. Received data is reclocked and retransmitted on the TxDA output.

2. The receive clock is used for the transmitter.
3. Received data is not sent to the local CPU, and the error status conditions are inactive.
4. The received parity is not checked and is not regenerated for transmission, i.e., transmitted parity bit is as received.
5. The receiver must be enabled.
6. Character framing is not checked, and the stop bits are retransmitted as received.
7. A received break is echoed as received until the next valid start bit is detected.

The user must exercise care when switching into and out of the various modes. The selected mode will be activated immediately upon mode selection, even if this occurs in the middle of a received or transmitted character. Likewise, if a mode is deselected, the device will switch out of the mode immediately. An exception to this is switching out of autoecho or remote loopback modes: if the de-selection occurs just after the receiver has sampled the stop bit (indicated in autoecho by assertion of RxRDY), and the transmitter is enabled, the transmitter will remain in autoecho mode until the entire stop bit has been retransmitted.

#### MR2A[5] — Channel A Transmitter Request-to-Send Control

This bit controls the deactivation of the RTSAN output (OP0) by the transmitter. This output is normally asserted by setting OPR[0] and negated by resetting OPR[0]. MR2A[5] = 1 causes OPR[0] to be reset automatically one bit time after the characters in the channel A transmit shift register and in the THR, if any, are completely transmitted, including the programmed number of stop bits, if the transmitter is not enabled. This feature can be used to automatically terminate the transmission of a message as follows:

1. Program auto-reset mode: MR2A[5] = 1.
2. Enable transmitter.
3. Assert RTSAN: OPR[0] = 1.
4. Send message.
5. Verify the message is sent by waiting until the transmit ready status (TxRDY) is asserted. Disable transmitter after the last character is loaded into the channel A THR.
6. The last character will be transmitted and OPR[0] will be reset one bit time after the last stop bit, causing RTSAN to be negated.

#### MR2A[4] — Channel A Clear-to-Send Control

If this bit is 0, CTSAN has no effect on the transmitter. If this bit is a 1, the transmitter checks the state of CTSAN (IP0) each time it

is ready to send a character. If IP0 is asserted (low), the character is transmitted. If it is negated (high), the TxDA output remains in the marking state and the transmission is delayed until CTSAN goes low. Changes in CTSAN while a character is being transmitted do not affect the transmission of that character.

#### MR2A[3:0] — Channel A Stop Bit Length Select

This field programs the length of the stop bit appended to the transmitted character. Stop bit lengths of  $\frac{9}{16}$  to 1 and  $1\frac{9}{16}$  to 2 bits, in increments of  $\frac{1}{16}$  bit, can be programmed for character lengths of 6, 7, and 8 bits. For a character length of 5 bits,  $1\frac{1}{16}$  to 2 stop bits can be programmed in increments of  $\frac{1}{16}$  bit. The receiver only checks for a 'mark' condition at the center of the first stop bit position (one bit time after the last data bit, or after the parity bit if parity is enabled) in all cases.

If an external  $1\times$  clock is used for the transmitter, MR2A[3] = 0 selects one stop bit and MR2A[3] = 1 selects two stop bits to be transmitted.

#### MR1B — Channel B Mode Register 1

MR1B is accessed when the channel B MR pointer points to MR1. The pointer is set to MR1 by RESET or by a 'set pointer' command applied via CRB. After reading or writing MR1B, the pointer will point to MR2B.

The bit definitions for this register are identical to the bit definitions for MR1A, except that all control actions apply to the channel B receiver and transmitter and the corresponding inputs and outputs.

#### MR2B — Channel B Mode Register 2

MR2B is accessed when the channel B MR pointer points to MR2, which occurs after any access to MR1B. Accesses to MR2B do not change the pointer.

The bit definitions for this register are identical to the bit definitions for MR2A, except that all control actions apply to the channel B receiver and transmitter and the corresponding inputs and outputs.

#### CSRA — Channel A Clock Select Register

#### CSRA[7:4] — Channel A Receiver Clock Select

This field selects the baud rate clock for the channel A receiver as follows:

# Dual Asynchronous Receiver/Transmitter (DUART)

# SCC68692

Baud Rate Clock = 3.6864MHz		
CSRA[7:4]	ACR[7] = 0	ACR[7] = 1
0 0 0 0	50	75
0 0 0 1	110	110
0 0 1 0	134.5	134.5
0 0 1 1	200	150
0 1 0 0	300	300
0 1 0 1	600	600
0 1 1 0	1,200	1,200
0 1 1 1	1,050	2,000
1 0 0 0	2,400	2,400
1 0 0 1	4,800	4,800
1 0 1 0	7,200	1,800
1 0 1 1	9,600	9,600
1 1 0 0	38.4k	19.2k
1 1 0 1	Timer	Timer
1 1 1 0	IP4 — 16×	IP4 — 16×
1 1 1 1	IP4 — 1×	IP4 — 1×

The receiver clock is always a 16 × clock except for CSRA[7:4] = 1111.

### CSRA[3:0] — Channel A Transmitter Clock Select

This field selects the baud rate clock for the channel A transmitter. The field definition is as per CSRA[7:4] except as follows:

Baud Rate		
CSRA[3:0]	ACR[7] = 0	ACR[7] = 1
1 1 1 0	IP3 — 16×	IP3 — 16×
1 1 1 1	IP3 — 1×	IP3 — 1×

The transmitter clock is always a 16 × clock except for CSRA[3:0] = 1111.

### CSRB — Channel B Clock Select Register

#### CSRB[7:4] — Channel B Receiver Clock Select

This field selects the baud rate clock for the channel B receiver. The field definition is as per CSRA[7:4] except as follows:

Baud Rate		
CSRB[7:4]	ACR[7] = 0	ACR[7] = 1
1 1 1 0	IP2 — 16×	IP2 — 16×
1 1 1 1	IP2 — 1×	IP2 — 1×

The receiver clock is always a 16 × clock except for CSRB[7:4] = 1111.

#### CSRB[3:0] — Channel B Transmitter Clock Select

This field selects the baud rate clock for the channel B transmitter. The field definition is as per CSRA[7:4] except as follows:

Baud Rate		
CSRB[3:0]	ACR[7] = 0	ACR[7] = 1
1 1 1 0	IP5 — 16×	IP5 — 16×
1 1 1 1	IP5 — 1×	IP5 — 1×

The transmitter clock is always a 16 × clock except for CSRB[3:0] = 1111

### CRA — Channel A Command Register

CRA is a register used to supply commands to channel A. Multiple commands can be

specified in a single write to CRA as long as the commands are non-conflicting; e.g., the "enable transmitter" and "reset transmitter" commands cannot be specified in a single command word.

#### CRA[6:4] — Channel A Miscellaneous Commands

The encoded value of this field may be used to specify a single command as follows:

CRA[7:4]	COMMAND
0 0 0 0	No command.
0 0 0 1	Reset MR pointer. Causes the channel A MR pointer to point to MR1.
0 0 1 0	Reset receiver. Resets the channel A receiver as if a hardware reset had been applied. The receiver is disabled and the FIFO is flushed.
0 0 1 1	Reset transmitter. Resets the channel A transmitter as if a hardware reset had been applied.
0 1 0 0	Reset error status. Clears the channel A Received Break, Parity Error, Framing Error, and Overrun Error bits in the status register (SRA[7:4]). Used in character mode to clear OE status (although RB, PE, and FE bits will also be cleared) and in block mode to clear all error status after a block of data has been received.
0 1 0 1	Reset channel A break change interrupt. Causes the channel A break detect change bit in the interrupt status register (ISR[2]) to be cleared to zero.
0 1 1 0	Start break. Forces the TxDA output low (spacing). If the transmitter is empty the start of the break condition will be delayed up to two bit times. If the transmitter is active the break begins when transmission of the character is completed. If a character is in the THR, the start of the break will be delayed until that character, or any others loaded subsequently are transmitted. The transmitter must be enabled for this command to be accepted.
0 1 1 1	Stop Break. The TxDA line will go high (marking) within two bit times. TxDA will remain high for one bit time before the next character, if any, is transmitted.
1 0 0 0	Assert RTSN. Causes the RTSN output to be asserted (low).
1 0 0 1	Negate RTSN. Causes the RTSN output to be negated (high).

1 0 1 0	Set special time-out mode on with this channel as the channel to restart the C/T as each receive character is transferred from the serial shift register to the RHR.
1 0 1 1	Not used.
1 1 0 0	Reset special time-out mode.
1 1 0 1	Not used.
1 1 1 0	Power Down mode on. In this mode, the DUART oscillator is stopped and all functions requiring this clock are suspended. The contents of all registers are saved. It is recommended that the transmitter and receiver be disabled prior to placing the DUART in this mode. This bit is reset with the assertion of RESET. This command is in CRA only. <b>Design Note:</b> The part will not output DTACKN while in Power Down mode, use automatic DTACKN generation.
1 1 1 1	Power Down Mode Normal Run. This command resets the Power Down mode. This command is in CRA only.

**CRA[3] — Disable Channel A Transmitter**  
This command terminates transmitter operation and resets the TxRDY and TxEMT status bits. However, if a character is being transmitted or if a character is in the THR when the transmitter is disabled, the transmission of the character(s) is completed before assuming the inactive state.

**CRA[2] — Enable Channel A Transmitter**  
Enables operation of the channel A transmitter. The TxRDY status bit will be asserted.

**CRA[1] — Disable Channel A Receiver**  
This command terminates operation of the receiver immediately — a character being received will be lost. The command has no effect on the receiver status bits or any other control registers. If the special multidrop mode is programmed, the receiver operates even if it is disabled. See Operation section.

**CRA[0] — Enable Channel A Receiver**  
Enables operation of the channel A receiver. If not in the special wake-up mode, this also forces the receiver into the search for start-bit state.

### CRB — Channel B Command Register

CRB is a register used to supply commands to channel B. Multiple commands can be specified in a single write to CRB as long as the commands are non-conflicting; e.g., the "enable transmitter" and "reset transmitter" commands cannot be specified in a single command word.

## Dual Asynchronous Receiver/Transmitter (DUART)

SCC68692

The bit definitions for this register are identical to the bit definitions for CRA with the exceptions of the last two commands "EX" and "FX" which are used for power down mode. These two commands are not used in CRB. All other control actions that apply to CRA also apply to CRB.

### SRA — Channel A Status Register

#### SRA[7] — Channel A Received Break

This bit indicates that an all zero character of the programmed length has been received without a stop bit. Only a single FIFO position is occupied when a break is received; further entries to the FIFO are inhibited until the RxD line returns to the marking state for at least one-half a bit time (two successive edges of the internal or external  $1 \times$  clock).

When this bit is set, the channel A "change in break" bit in the ISR (ISR[2]) is set. ISR[2] is also set when the end of the break condition, as defined above, is detected.

The break detect circuitry can detect breaks that originate in the middle of a received character. However, if a break begins in the middle of a character, it must persist until at least the end of the next character time in order for it to be detected.

#### SRA[6] — Channel A Framing Error

This bit, when set, indicates that a stop bit was not detected when the corresponding data character in the FIFO was received. The stop bit check is made in the middle of the first stop bit position.

#### SRA[5] — Channel A Parity Error

This bit is set when the "with parity" or "force parity" mode is programmed and the corresponding character in the FIFO was received with incorrect parity.

In the special multidrop mode the parity error bit stores the received A/D bit.

#### SRA[4] — Channel A Overrun Error

This bit, when set, indicates that one or more characters in the received data stream have been lost. It is set upon receipt of a new character when the FIFO is full and a character is already in the receive shift register waiting for an empty FIFO position. When this occurs, the character in the receive shift register (and its break detect, parity error and framing error status, if any) is lost.

This bit is cleared by a "reset error status" command.

#### SRA[3] — Channel A Transmitter Empty (TxEMTA)

This bit will be set when the channel A transmitter underruns; i.e., both the transmit holding register (THR) and the transmit shift register are empty. It is set after transmission of the last stop bit of a character if no

character is in the THR awaiting transmission. It is reset when the THR is loaded by the CPU or when the transmitter is disabled.

#### SRA[2] — Channel A Transmitter Ready (TxRDYA)

This bit, when set, indicates that the THR is empty and ready to be loaded with a character. This bit is cleared when the THR is loaded by the CPU and is set when the character is transferred to the transmit shift register. TxRDY is reset when the transmitter is disabled and is set when the transmitter is first enabled, viz., characters loaded into the THR while the transmitter is disabled will not be transmitted.

#### SRA[1] — Channel A FIFO Full (FFULLA)

This bit is set when a character is transferred from the receive shift register to the receive FIFO and the transfer causes the FIFO to become full; i.e., all three FIFO positions are occupied. It is reset when the CPU reads the RHR. If a character is waiting in the receive shift register because the FIFO is full, FFULL will not be reset when the CPU reads the RHR.

#### SRA[0] — Channel A Receiver Ready (RxRDYA)

This bit indicates that a character has been received and is waiting in the FIFO to be read by the CPU. It is set when the character is transferred from the receive shift register to the FIFO and reset when the CPU reads the RHR, only if (after this read) there are no more characters still in the FIFO.

### SRB — Channel B Status Register

The bit definitions for this register are identical to the bit definitions for SRA, except that all status applies to the channel B receiver and transmitter and the corresponding inputs and outputs.

### OPCR — Output Port Configuration Register

#### OPCR[7] — OP7 Output Select

This bit programs the OP7 output to provide one of following:

- The complement of OPR[7]
- The channel B transmitter interrupt output, which is the complement of TxRDYB. When in this mode OP7 acts as an open-drain output. Note that this output is not masked by the contents of the IMR.

#### OPCR[6] — OP6 Output Select

This bit programs the OP6 output to provide one of the following:

- The complement of OPR[6]
- The channel A transmitter interrupt output, which is the complement of TxRDYA. When in this mode OP6 acts as an open-drain output. Note that this output is not masked by the contents of the IMR.

#### OPCR[5] — OP5 Output Select

This bit programs the OP5 output to provide one of the following:

- The complement of OPR[5]
- The channel B receiver interrupt output, which is the complement of ISR[5]. When in this mode OP5 acts as an open-drain output. Note that this output is not masked by the contents of the IMR.

#### OPCR[4] — OP4 Output Select

This bit programs the OP4 output to provide one of the following:

- The complement of OPR[4]
- The channel A receiver interrupt output, which is the complement of ISR[1]. When in this mode OP4 acts as an open-drain output. Note that this output is not masked by the contents of the IMR.

#### OPCR[3:2] — OP3 Output Select

This field programs the OP3 output to provide one of the following:

- The complement of OPR[3]
- The counter/timer output, in which case OP3 acts as an open-drain output. In the timer mode, this output is a square wave at the programmed frequency. In the counter mode, the output remains high until terminal count is reached, at which time it goes low. The output returns to the high state when the counter is stopped by a stop counter command. Note that this output is not masked by the contents of the IMR.
- The  $1 \times$  clock for the channel B transmitter, which is the clock that shifts the transmitted data. If data is not being transmitted, a free running  $1 \times$  clock is output.
- The  $1 \times$  clock for the channel B receiver, which is the clock that samples the received data. If data is not being received, a free running  $1 \times$  clock is output.

#### OPCR[1:0] — OP2 Output Select

This field programs the OP2 output to provide one of the following:

- The complement of OPR[2]
- The  $16 \times$  clock for the channel A transmitter. This is the clock selected by CSRA[3:0], and will be  $1 \times$  clock if CSRA[3:0] = 1111.
- The  $1 \times$  clock for the channel A transmitter, which is the clock that shifts the transmitted data. If data is not being transmitted, a free running  $1 \times$  clock is output.
- The  $1 \times$  clock for the channel A receiver, which is the clock that samples the received data. If data is not being received, a free running  $1 \times$  clock is output.

### ACR — Auxiliary Control Register

#### ACR[7] — Baud Rate Generator Set Select

This bit selects one of two sets of baud rates to be generated by the BRG:

## Dual Asynchronous Receiver/Transmitter (DUART)

SCC68692

**Table 3. Baud Rate Generator Characteristics Crystal or Clock = 3.6864MHz**

NOMINAL RATE (BAUD)	ACTUAL 16X CLOCK (KHz)	ERROR (PERCENT)
50	0.8	0
75	1.2	0
110	1.759	-0.069
134.5	2.153	0.059
150	2.4	0
200	3.2	0
300	4.8	0
600	9.6	0
1050	16.756	-0.260
1200	19.2	0
1800	28.8	0
2000	32.056	0.175
2400	38.4	0
4800	76.8	0
7200	115.2	0
9600	153.6	0
19.2k	307.2	0
38.4k	614.4	0

**NOTE:**

Duty cycle of 16x clock is 50% ±1%

**Table 4. ACR [6:4] Field Definition**

ACR [6:4]	MODE	CLOCK SOURCE
0 0 0	Counter	External (IP2) <sup>1</sup>
0 0 1	Counter	TxCA — 1x clock of channel A transmitter
0 1 0	Counter	TxCB — 1x clock of channel B transmitter
0 1 1	Counter	Crystal or external clock (X1/CLK) divided by 16
1 0 0	Timer	External (IP2) <sup>1</sup>
1 0 1	Timer	External (IP2) divided by 16 <sup>1</sup>
1 1 0	Timer	Crystal or external clock (X1/CLK)
1 1 1	Timer	Crystal or external clock (X1/CLK) divided by 16

**NOTE:**

1. In these modes, the channel B receiver clock should normally be generated from the baud rate generator.

Set 1: 50, 110, 134.5, 200, 300, 600, 1.05k, 1.2k, 2.4k, 4.8k, 7.2k, 9.6k, and 38.4k baud.

Set 2: 75, 110, 134.5, 150, 300, 600, 1.2k, 1.8k, 2.0k, 2.4k, 4.8k, 9.6k, and 19.2k baud.

The selected set of rates is available for use by the channel A and B receivers and transmitters as described in CSRA and CSRB. Baud rate generator characteristics are given in Table 3.

**ACR[6:4] — Counter/Timer Mode and Clock Source Select**

This field selects the operating mode of the counter/timer and its clock source as shown in Table 4.

**ACR[3:0] — IP3, IP2, IP1, IP0 Change of State Interrupt Enable**

This field selects which bits of the Input Port Change register (IPCR) cause the input change bit in the interrupt status register (ISR[7]) to be set. If a bit is in the "on" state, the setting of the corresponding bit in the

latched and reflects the state of the input pins at the time the IPCR is read.

**ISR — Interrupt Status Register**

This register provides the status of all potential interrupt sources. The contents of this register are masked by the interrupt mask register (IMR). If a bit in the ISR is a "1" and the corresponding bit in the IMR is also a "1", the INTRN output will be asserted. If the corresponding bit in the IMR is a zero, the state of the bit in the ISR has no effect on the INTRN output. Note that the IMR does not mask the reading of the ISR — the true status will be provided regardless of the contents of the IMR. The contents of this register are initialized to 00<sub>16</sub> when the DUART is reset.

**ISR[7] — Input Port Change Status**

This bit is a "1" when a change of state has occurred at the IP0, IP1, IP2, or IP3 inputs and that event has been selected to cause an interrupt by the programming of ACR[3:0]. The bit is cleared when the CPU reads the IPCR.

**ISR[6] — Channel B Change in Break**

This bit, when set, indicates that the channel B receiver has detected the beginning or the end of a received break. It is reset when the CPU issues a channel B "reset break change interrupt" command.

**ISR[5] — Channel B Receiver Ready or FIFO Full**

The function of this bit is programmed by MR1B[6]. If programmed as receiver ready, it indicates that a character has been received in channel B and is waiting in the FIFO to be read by the CPU. It is set when the character is transferred from the receive shift register to the FIFO and reset when the CPU reads the RHR. If after this read there are more characters still in the FIFO the bit will be set again after the FIFO is "popped". If programmed as FIFO full, it is set when a character is transferred from the receive holding register to the receive FIFO and the transfer causes the channel B FIFO to become full; i.e., all three FIFO positions are occupied. It is reset when the CPU reads the RHR. If a character is waiting in the receive shift register because the FIFO is full, the bit will be set again when the waiting character is loaded into the FIFO.

**ISR[4] — Channel B Transmitter Ready**

This bit is a duplicate of TxRDYB (SRB[2]).

**ISR[3] — Counter Ready**

In the counter mode, this bit is set when the counter reaches terminal count and is reset when the counter is stopped by a stop counter command.

In the timer mode, this bit is set once each cycle of the generated square wave (every other time that the counter/timer reaches zero count). The bit is reset by a stop counter

IPCR will also result in the setting of ISR[7], which results in the generation of an interrupt output if IMR[7] = 1. If a bit is in the "off" state, the setting of that bit in the IPCR has no effect on ISR[7].

**IPCR — Input Port Change Register****IPCR[7:4] — IP3, IP2, IP1, IP0 Change of State**

These bits are set when a change of state, as defined in the Input Port section of this data sheet, occurs at the respective input pins. They are cleared when the IPCR is read by the CPU. A read of the IPCR also clears ISR[7], the input change bit in the interrupt status register.

The setting of these bits can be programmed to generate an interrupt to the CPU.

**IPCR[3:0] — IP3, IP2, IP1, IP0 Current State**

These bits provide the current state of the respective inputs. The information is un-

## Dual Asynchronous Receiver/Transmitter (DUART)

SCC68692

command. The command, however, does not stop the counter/timer.

**ISR[2] — Channel A Change in Break**

This bit, when set, indicates that the channel A receiver has detected the beginning or the end of a received break. It is reset when the CPU issues a channel A "reset break change interrupt" command.

**ISR[1] — Channel A Receiver Ready or FIFO Full**

The function of this bit is programmed by MR1A[6]. If programmed as receiver ready, it indicates that a character has been received in channel A and is waiting in the FIFO to be read by the CPU. It is set when the character is transferred from the receive shift register to the FIFO and reset when the CPU reads the RHR. If after this read there are more characters still in the FIFO the bit will be set again after the FIFO is "popped". If programmed as FIFO full, it is set when a character is transferred from the receive holding register to the receive FIFO and the transfer causes the channel A FIFO to become full; i.e., all three FIFO positions are occupied. It is reset when the CPU reads the RHR. If a character is waiting in the receive shift register because the FIFO is full, the bit will be set again when the waiting character is loaded into the FIFO.

**ISR[0] — Channel A Transmitter Ready**

This bit is a duplicate of TxRDYA (SRA[2]).

**IMR — Interrupt Mask Register**

The programming of this register selects which bits in the ISR cause an interrupt output. If a bit in the ISR is a "1" and the corresponding bit in the IMR is also a "1", the INTRN output will be asserted. If the corresponding bit in the IMR is a zero, the state of the bit in the ISR has no effect on the INTRN

output. Note that the IMR does not mask the programmable interrupt outputs OP3–OP7 or the reading of the ISR.

**CTUR and CTLR — Counter/Timer Registers**

The CTUR and CTLR hold the eight MSBs and eight LSBs respectively of the value to be used by the counter/timer in either the counter or timer modes of operation. The minimum value which may be loaded into the CTUR/CTLR registers is 0002<sub>16</sub>. Note that these registers are write-only and cannot be read by the CPU.

In the timer (programmable divider) mode, the C/T generates a square wave with a period of twice the value (in clock periods) of the CTUR and CTLR. If the value in CTUR or CTLR is changed, the current half-period will not be affected, but subsequent half periods will be. In this mode the C/T runs continuously. Receipt of a start counter command (read with A4–A1 = 1110) causes the counter to terminate the current timing cycle and to begin a new cycle using the values in CTUR and CTLR. The counter ready status bit (ISR[3]) is set once each cycle of the square wave. The bit is reset by a stop counter command (read with A4–A1 = 1111). The command, however, does not stop the C/T. The generated square wave is output on OP3 if it is programmed to be the C/T output.

On power-up and after reset, the timer/counter runs in timer mode and can only be restarted. Because it cannot be shut off or stopped, and runs continuously in timer mode, it is recommended that at initialization, the output port, OP3, should be masked off through the OPCR[3:2] = 00 until the T/C is programmed to the desired operational state.

In the counter mode, the C/T counts down the number of pulses loaded into CTUR and CTLR by the CPU. Counting begins upon receipt of a start counter command. Upon reaching terminal count (0000<sub>16</sub>), the counter ready interrupt bit (ISR[3]) is set. The counter continues counting past the terminal count until stopped by the CPU. If OP3 is programmed to be the output of the C/T, the output remains high until terminal count is reached, at which time it goes low. The output returns to the high state and ISR[3] is cleared when the counter is stopped by a stop counter command. The CPU may change the values of CTUR and CTLR at any time, but the new count becomes effective only on the next start counter command. If new values have not been loaded, the previous count values are preserved and used for the next count cycle.

In the counter mode, the current value of the upper and lower 8 bits of the counter (CTU, CTL) may be read by the CPU. It is recommended that the counter be stopped when reading to prevent potential problems which may occur if a carry from the lower 8 bits to the upper 8 bits occurs between the times that both halves of the counter are read. However, note that a subsequent start counter command will cause the counter to begin a new count cycle using the values in CTUR and CTLR.

**IVR — Interrupt Vector Register**

This register contains the interrupt vector. The register is initialized to H'0F by RESET. The contents of the register are placed on the data bus when the DUART responds to a valid interrupt acknowledge cycle.



## Dual Asynchronous Receiver/Transmitter (DUART)

SCC68692

ABSOLUTE MAXIMUM RATINGS<sup>1</sup>

SYMBOL	PARAMETER	RATING	UNIT
T <sub>A</sub>	Operating ambient temperature <sup>2</sup> range	0 to +70	°C
T <sub>STG</sub>	Storage temperature range	-65 to +150	°C
	All voltages with respect to ground <sup>3</sup>	-0.5 to +6.0	V

## NOTES:

- Stresses above those listed under Absolute Maximum Ratings may cause permanent damage to the device. This is a stress rating only and functional operation of the device at these or any other condition above those indicated in the operation section of this specification is not implied.
- For operating at elevated temperatures, the device must be derated based on +150°C maximum junction temperature.
- This product includes circuitry specifically designed for the protection of its internal devices from damaging effects of excessive static charge. Nonetheless, it is suggested that conventional precautions be taken to avoid applying any voltages larger than the rated maxima.

DC ELECTRICAL CHARACTERISTICS T<sub>A</sub> = 0°C to +70°C, V<sub>CC</sub> = 5V ± 5%<sup>4, 5, 6</sup>

SYMBOL	PARAMETER	TEST CONDITIONS	LIMITS			UNIT
			Min	Typ	Max	
V <sub>IL</sub>	Input low voltage				0.8	V
V <sub>IH</sub>	Input high voltage (except X1/CLK)		2			V
V <sub>IH</sub>	Input high voltage (X1/CLK)		0.9V <sub>CC</sub>		V <sub>CC</sub>	V
V <sub>OL</sub>	Output low voltage	I <sub>OL</sub> = 2.4mA			0.4	V
V <sub>OH</sub>	Output high voltage (except o.d. outputs)	I <sub>OH</sub> = -400μA	2.4			V
I <sub>IL</sub>	Input leakage current	V <sub>IN</sub> = 0 to V <sub>CC</sub>	-10		10	μA
I <sub>LL</sub>	Data bus 3-State leakage current	V <sub>O</sub> = 0.4 to V <sub>CC</sub>	-10		10	μA
I <sub>X1L</sub>	X1/CLK low input current	V <sub>IN</sub> = 0, X2 floated	-100	-30	0	μA
I <sub>X1H</sub>	X1/CLK high input current	V <sub>IN</sub> = V <sub>CC</sub> , X2 floated	0	+30	100	μA
I <sub>OD</sub>	Open-drain output leakage current	V <sub>O</sub> = 0.4 to V <sub>CC</sub>	-10		10	μA
I <sub>CC</sub>	Power supply current				150	mA
<b>When oscillator is in power-down mode:</b>						
I <sub>X1H</sub>	X1/CLK high input current	V <sub>IN</sub> = V <sub>CC</sub> , X2 floated	2	6	10	mA
I <sub>CC</sub>	Power supply current Standby			0.8	4	mA
					500	μA

## NOTES:

- Parameters are valid over specified temperature range.
- All voltage measurements are referenced to ground (GND). For testing, all inputs except X1/CLK swing between 0.4V and 2.4V with a transition time of 20ns maximum. For X1/CLK, this swing is between 0.4V and 4.4V. All time measurements are referenced at input voltages of 0.8V and 2V as appropriate.
- Typical values are at +25°C, typical supply voltages, and typical processing parameters.
- Test condition for outputs: C<sub>L</sub> = 150pF, except interrupt outputs. Test condition for interrupt outputs: C<sub>L</sub> = 50pF, R<sub>L</sub> = 2.7kΩ to V<sub>CC</sub>.
- This specification will impose maximum 68000 CPU CLK to 6MHz. Higher CPU CLK can be used if repeating bus reads are not performed. Consecutive write operations to the same command register require at least three edges of the X1 clock between writes.
- This specification imposes a lower bound on CSN and IACKN low, guaranteeing that it will be low for at least 1 CLK period. This requirement is made on CSN only to insure assertion of DTACKN and not to guarantee operation of the part.
- This specification is made only to insure that DTACKN is asserted with respect to the rising edge of the X1/CLK pin as shown in the timing diagram, not to guarantee operation of the part. If the setup time is violated, DTACKN may be asserted as shown, or may be asserted one clock cycle later.

## Dual Asynchronous Receiver/Transmitter (DUART)

SCC68692

AC ELECTRICAL CHARACTERISTICS  $T_A = 0^\circ\text{C}$  to  $+70^\circ\text{C}$ ,  $V_{CC} = 5.0\text{V} \pm 5\%$ <sup>4, 5, 6, 7</sup>

SYMBOL	PARAMETER	LIMITS			UNIT
		Min	Typ	Max	
<b>Reset timing (Figure 1)</b>					
$t_{RES}$	RESETN pulse width	1			$\mu\text{s}$
<b>Bus timing (Figures 2, 3, 4)</b>					
$t_{AS}$	A1–A4 setup time to CSN low	10			ns
$t_{AH}$	A1–A4 hold time from CSN high	0			ns
$t_{RWS}$	RWN setup time to CSN high	0			ns
$t_{RWH}$	RWN holdup time to CSN high	0			ns
$t_{CSW}^8$	CSN high pulse width	160			ns
$t_{CSD}^9$	CSN or IACKN high from DTACKN low	20			ns
$t_{DD}$	Data valid from CSN or IACKN low			175	ns
$t_{DF}$	Data bus floating from CSN or IACKN high			65	ns
$t_{DS}$	Data setup time to CLK high	100			ns
$t_{DH}$	Data hold time from CSN high	0			ns
$t_{DAL}$	DTACKN low from read data valid	0			ns
$t_{DCR}$	DTACKN low (read cycle) from CLK high			125	ns
$t_{DCW}$	DTACKN low (write cycle) from CLK high			125	ns
$t_{DAH}$	DTACKN high from CSN or IACKN high			100	ns
$t_{DAT}$	DTACKN high impedance from CSN or IACKN high			125	ns
$t_{CSC}^{10}$	CSN or IACKN setup time to clock high	90			ns
<b>Port timing (Figure 5)</b>					
$t_{PS}$	Port input setup time to CSN low	0			ns
$t_{PH}$	Port input hold time from CSN high	0			ns
$t_{PD}$	Port output valid from CSN high			370	ns
<b>Interrupt reset timing (Figure 6)</b>					
$t_{IR}$	INTRN, or OP3–OP7 when used as interrupts, negated from: Read RHR (RxRDY/FFULL interrupt) Write THR (TxRDY interrupt) Reset command (delta break interrupt) Stop C/T command (counter interrupt) Read IPCR (input port change interrupt) Write IMR (clear of interrupt mask bit)			370 370 370 370 370 270	ns ns ns ns ns ns
<b>Clock timing (Figure 7)</b>					
$t_{CLK}$	X1/CLK high or low time	100			ns
$f_{CLK}$	X1/CLK frequency	2	3.6864	4	MHz
$t_{CTC}$	CTCLK high or low time	100			ns
$f_{CTC}$	CTCLK frequency	100		4M	Hz
$t_{RX}$	RxC high or low time	220			ns
$f_{RX}$	RxC frequency (16 $\times$ )	100		2M	Hz
	(1 $\times$ )	100		1M	Hz
$t_{TX}$	TxC high or low time	220			ns
$f_{TX}$	TxC frequency (16 $\times$ )	0		2	MHz
	(1 $\times$ )	0		1	MHz
<b>Transmitter timing (Figure 8)</b>					
$t_{TXD}$	TxD output delay from TxC low			350	ns
$t_{TCS}$	Output delay from TxC low to TxD data output			150	ns
<b>Receiver timing (Figure 9)</b>					
$t_{RXS}$	RxD data setup time to RxC high	240			ns
$t_{RXH}$	RxD data hold time from RxC high	200			ns

# Dual Asynchronous Receiver/Transmitter (DUART)

SCC68692

2

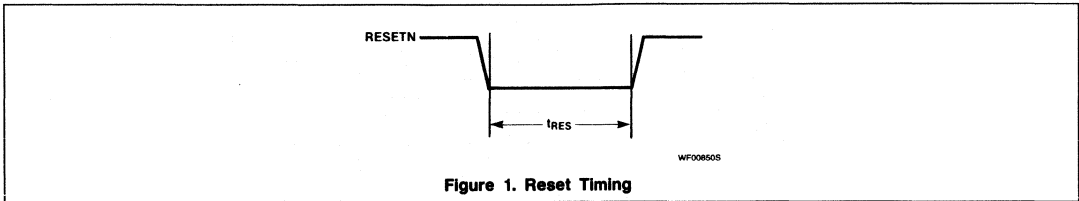

Figure 1. Reset Timing

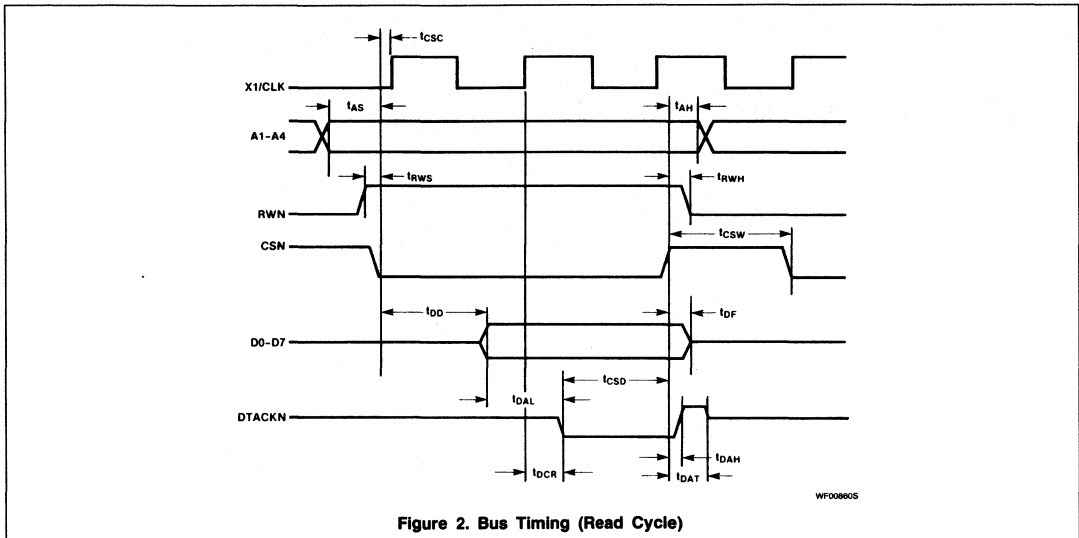

Figure 2. Bus Timing (Read Cycle)

# Dual Asynchronous Receiver/Transmitter (DUART)

SCC68692

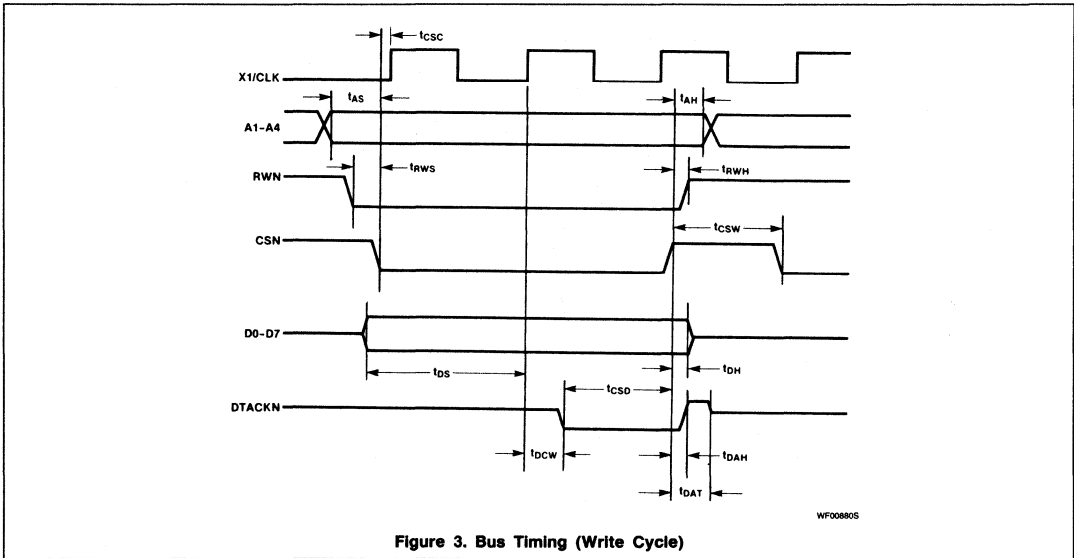

Figure 3. Bus Timing (Write Cycle)

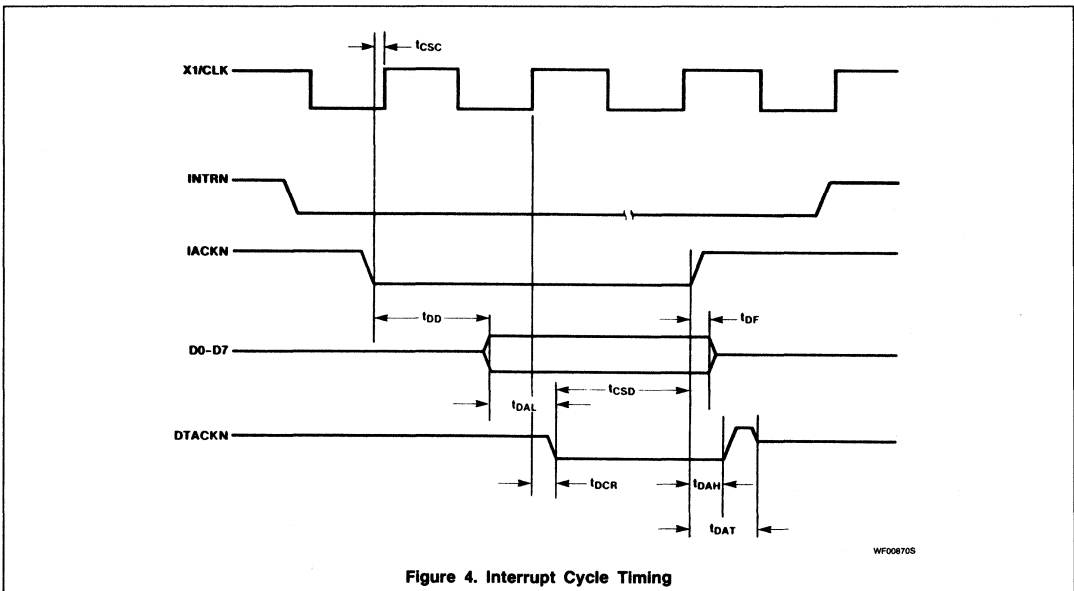

Figure 4. Interrupt Cycle Timing

# Dual Asynchronous Receiver/Transmitter (DUART)

SCC68692

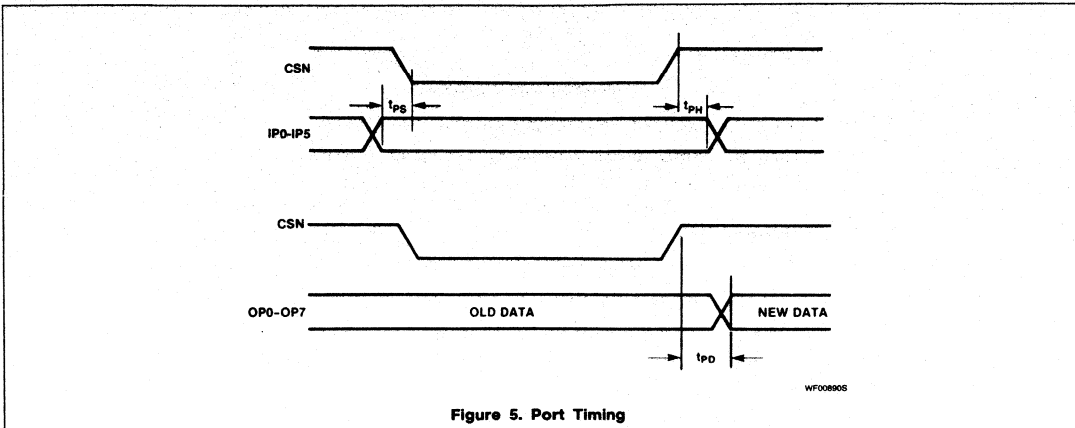
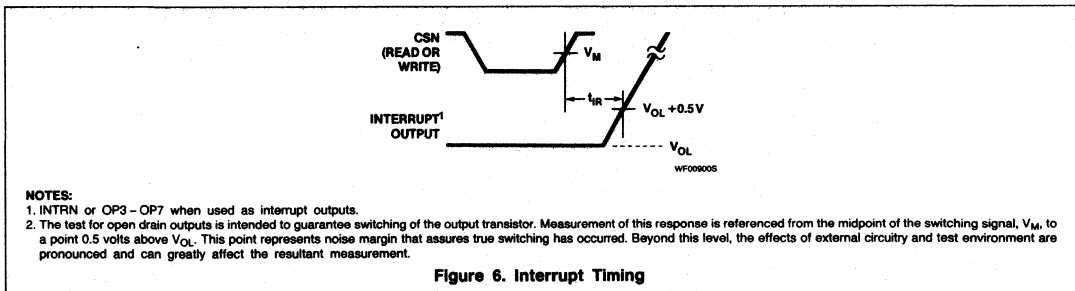

Figure 5. Port Timing



**NOTES:**

1. INTRN or OP3 - OP7 when used as interrupt outputs.
2. The test for open drain outputs is intended to guarantee switching of the output transistor. Measurement of this response is referenced from the midpoint of the switching signal,  $V_M$ , to a point 0.5 volts above  $V_{OL}$ . This point represents noise margin that assures true switching has occurred. Beyond this level, the effects of external circuitry and test environment are pronounced and can greatly affect the resultant measurement.

Figure 6. Interrupt Timing

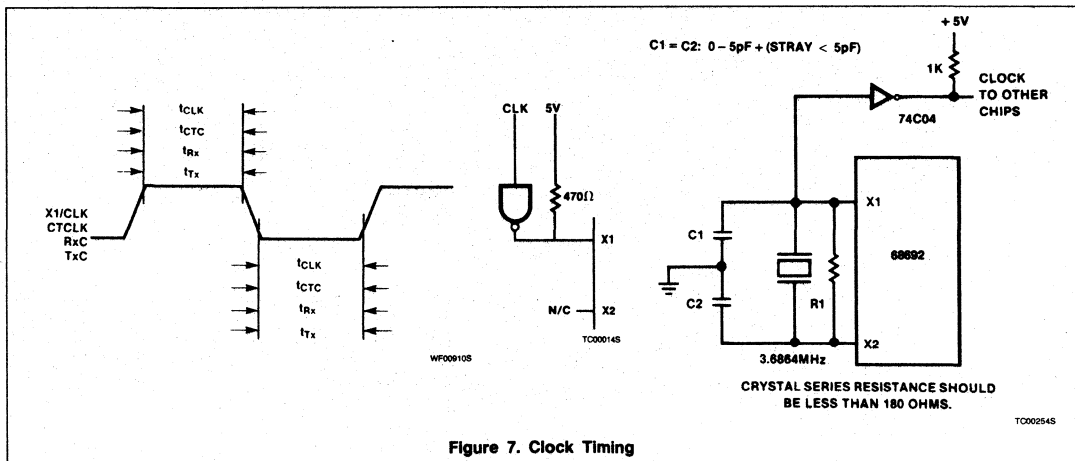
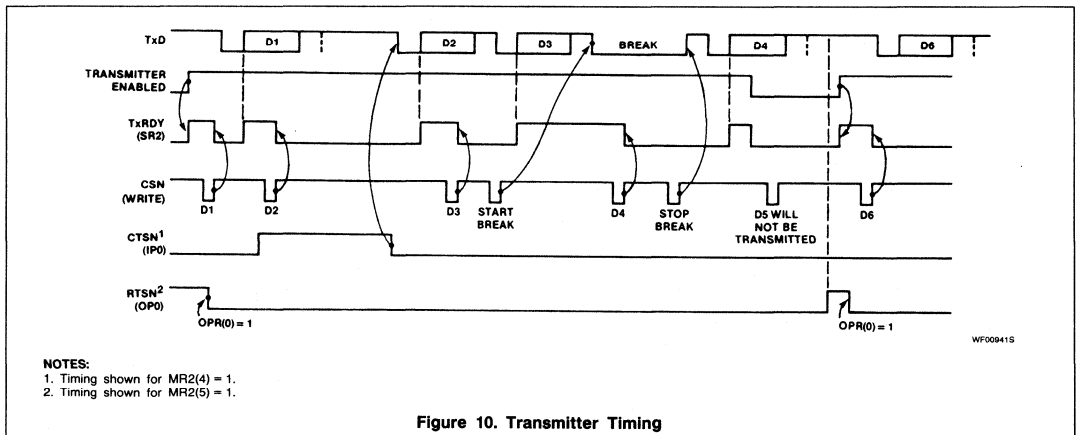
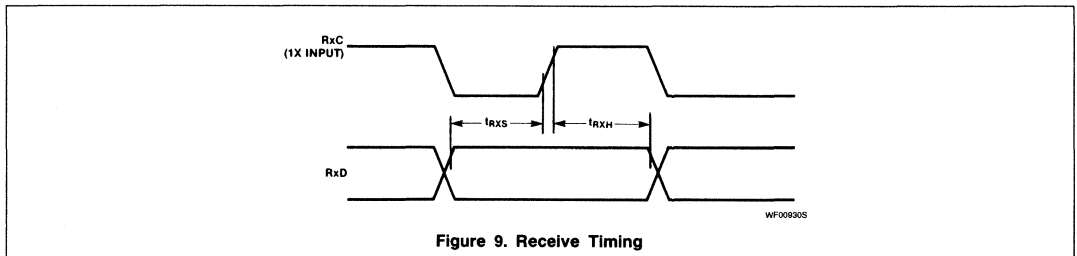
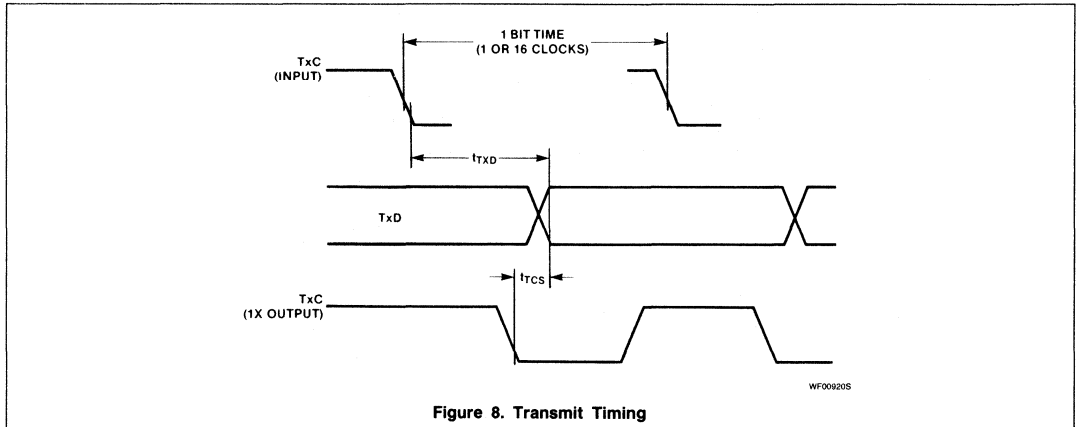

Figure 7. Clock Timing

# Dual Asynchronous Receiver/Transmitter (DUART)

SCC68692



# Dual Asynchronous Receiver/Transmitter (DUART)

SCC68692

2

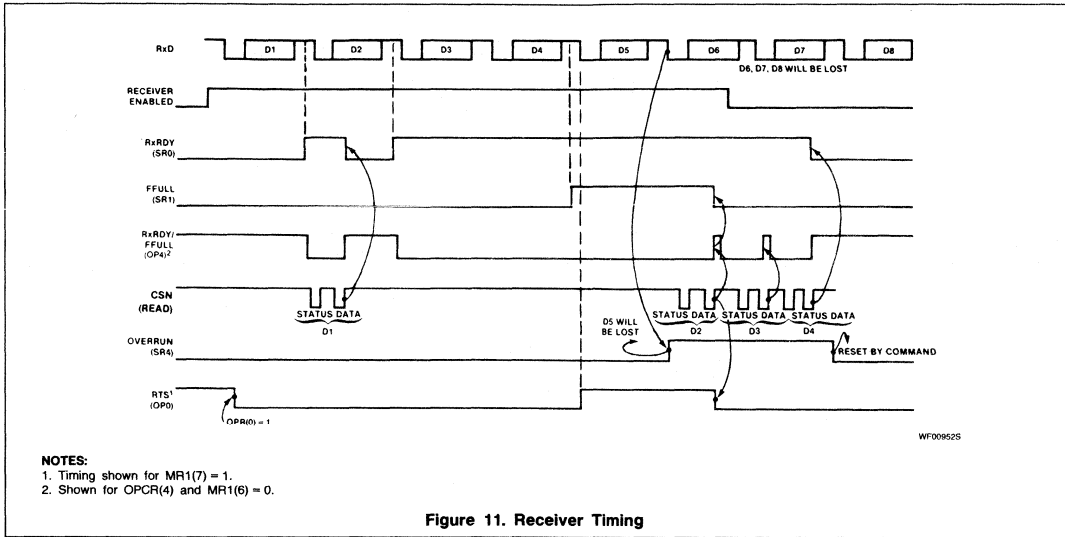

Figure 11. Receiver Timing

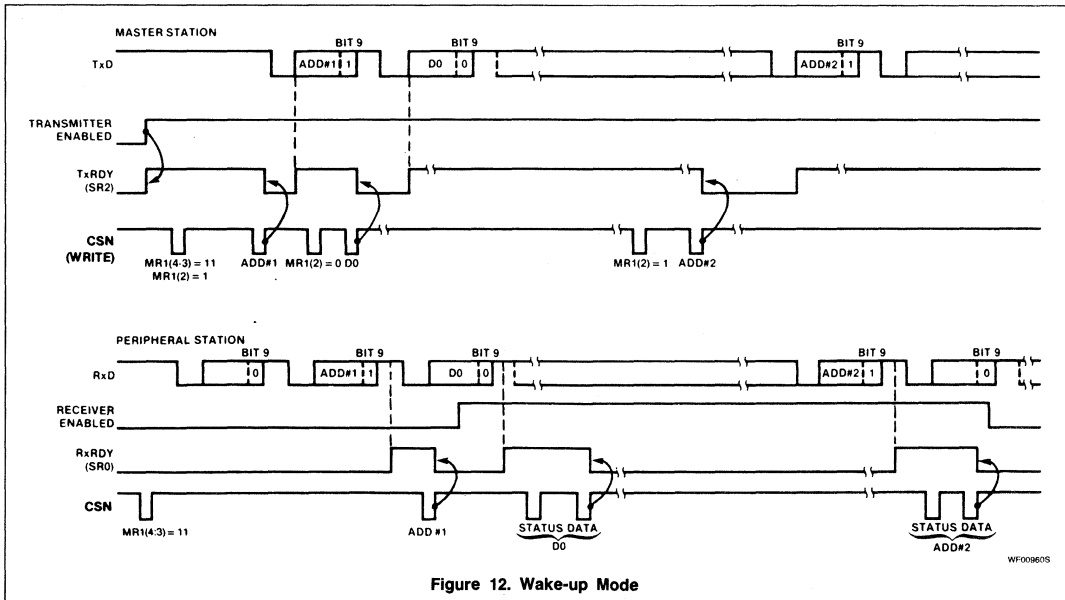

Figure 12. Wake-up Mode





# Section 4 Package Outlines

Microprocessor Products

## INDEX

A	Plastic Leaded Chip Carrier .....	4-3
D	Plastic Small Outline .....	4-6
F	Hermetic CERDIP .....	4-8
I	Hermetic SDIP .....	4-9
N	Plastic DIP .....	4-13
P	Grid Array .....	4-18



# Package Outlines

## 28-PIN PLASTIC LEADED CHIP CARRIER

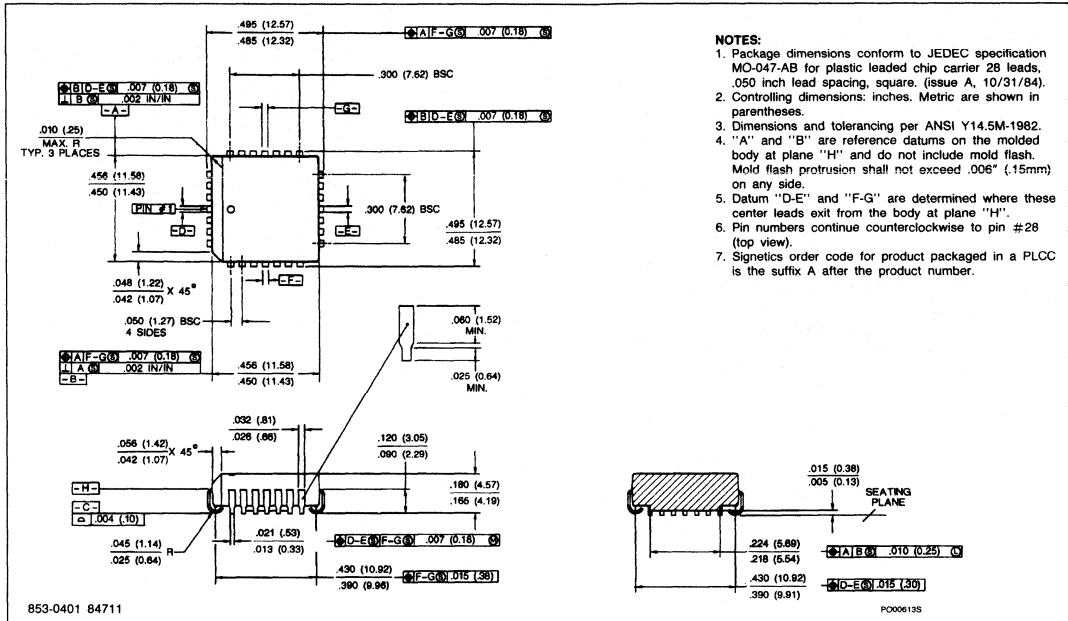

4

## 44-PIN PLASTIC LEADED CHIP CARRIER

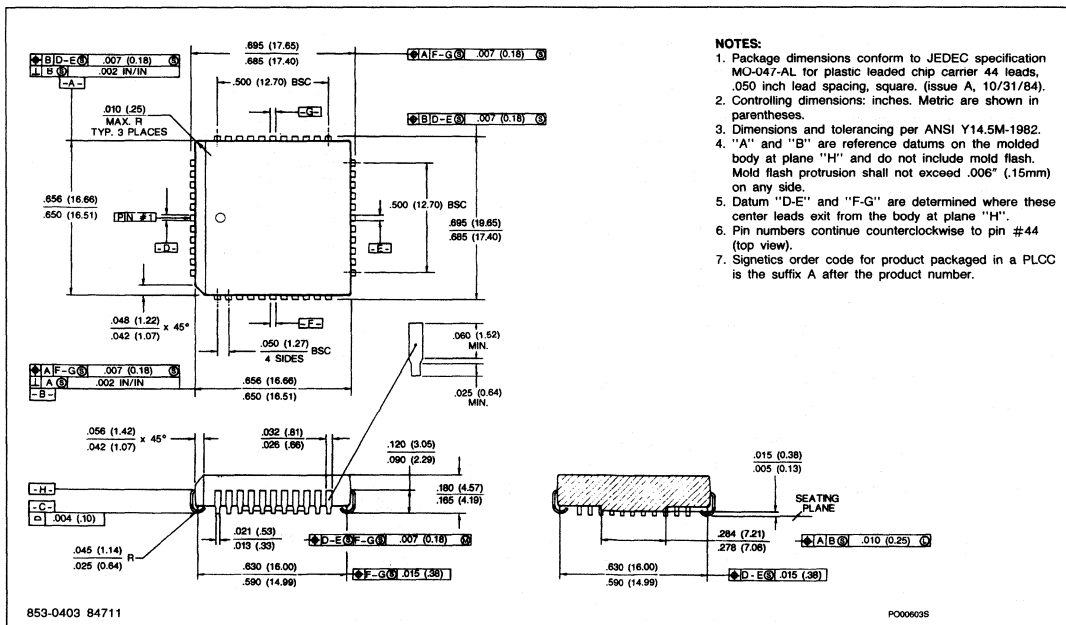

# Package Outlines

## 52-PIN PLASTIC LEADED CHIP CARRIER

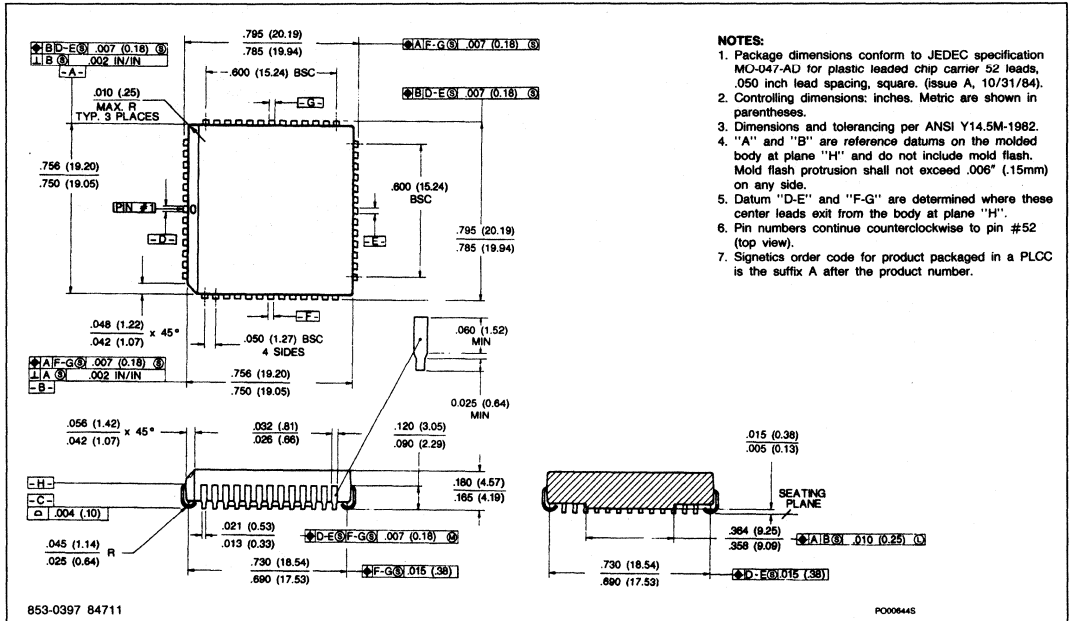

## 68-PIN PLASTIC LEADED CHIP CARRIER

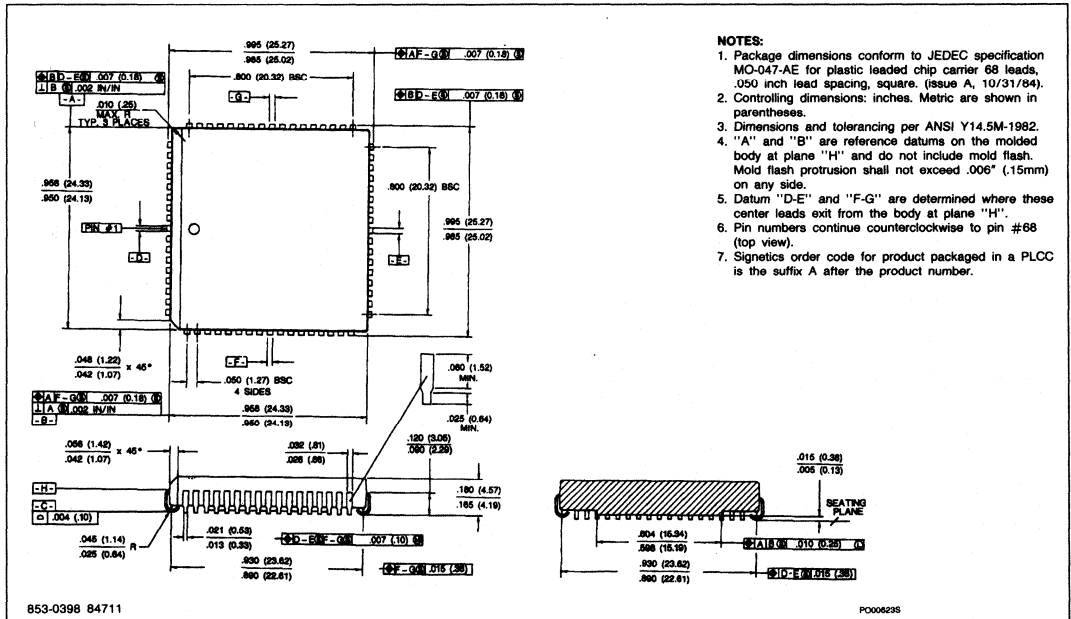

# Package Outlines

## 84-PIN PLASTIC LEADED CHIP CARRIER

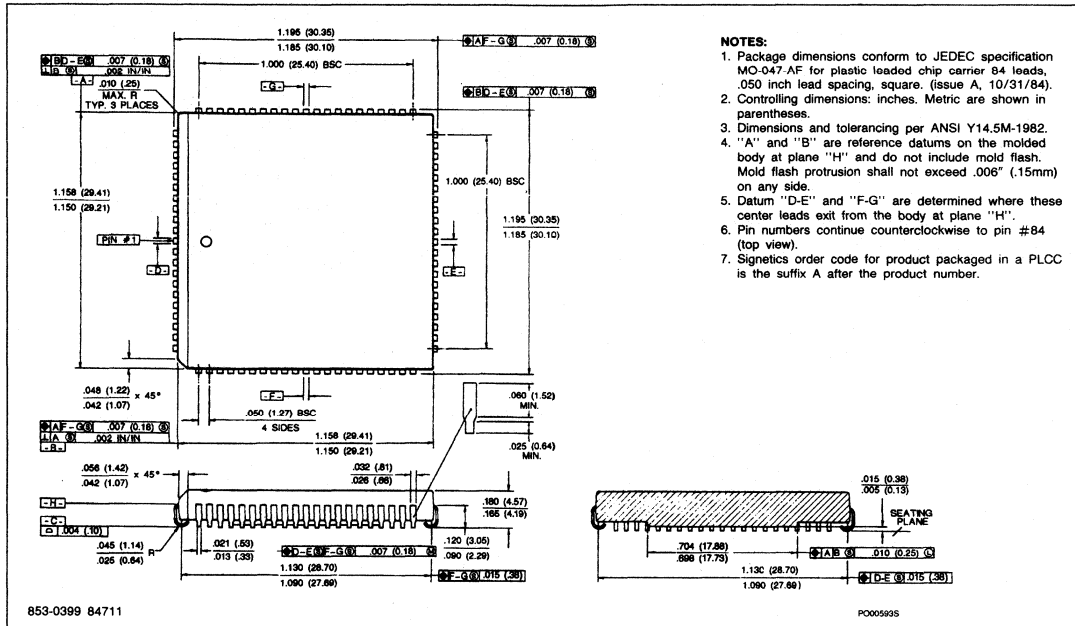

# Package Outlines

## 16-PIN PLASTIC SO

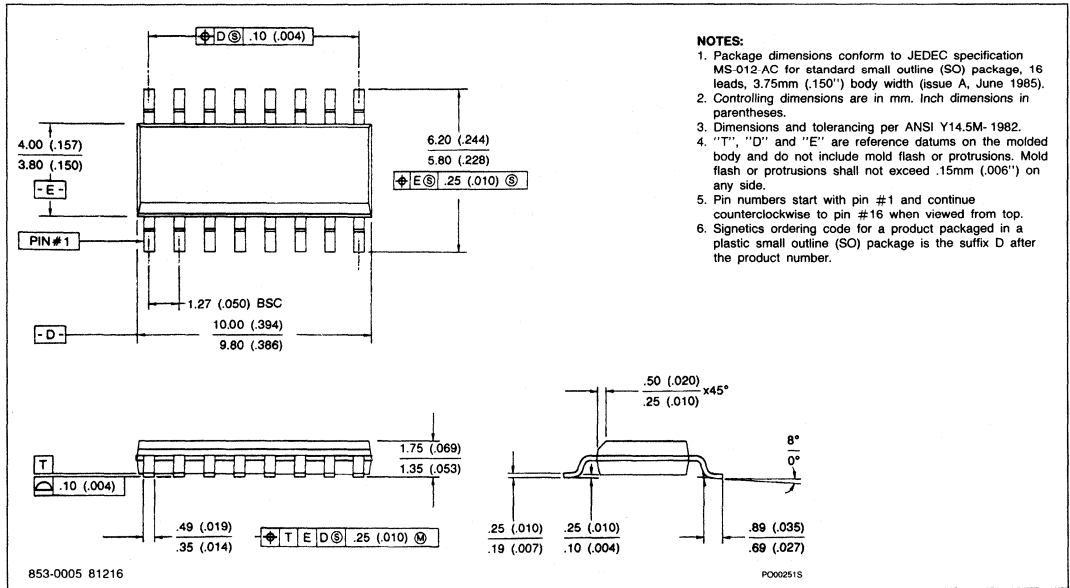

## 20-PIN PLASTIC SOL

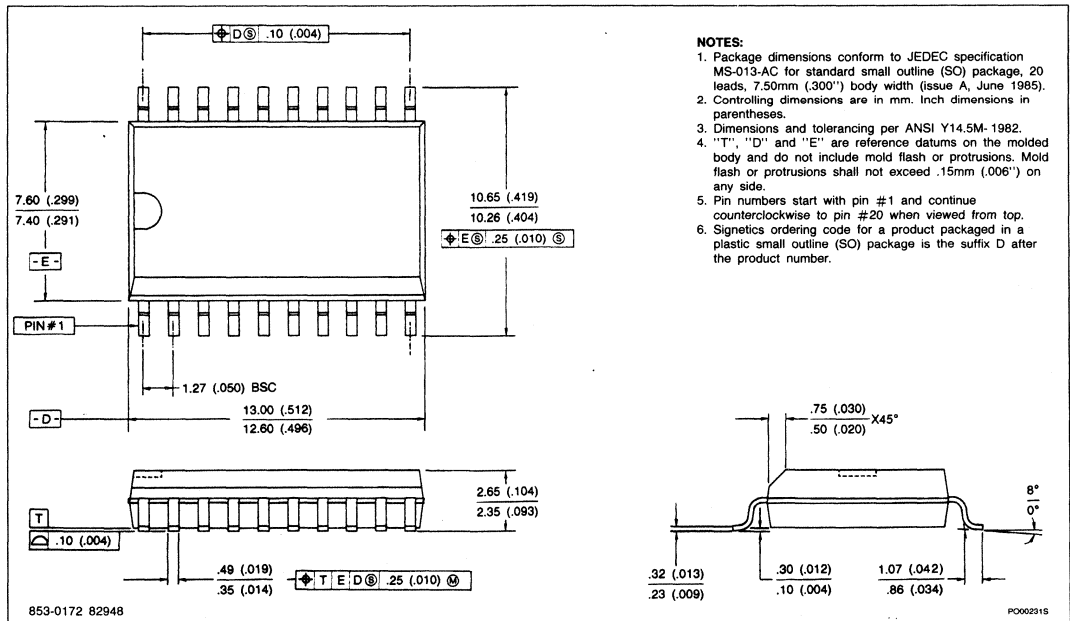

# Package Outlines

## 24-PIN PLASTIC SOL

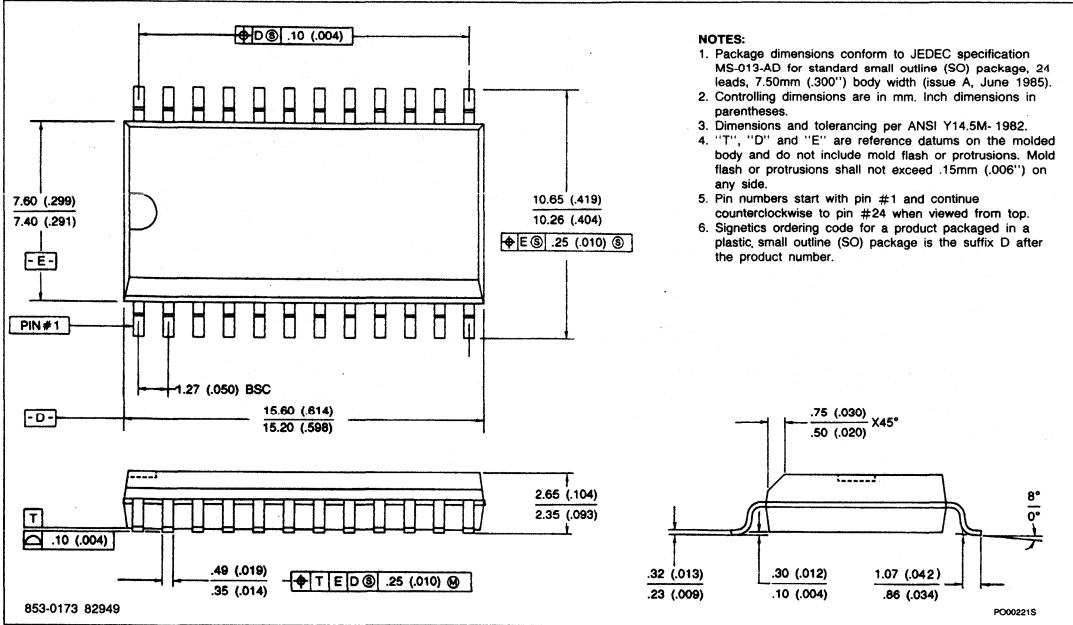

# Package Outlines

## 20-PIN HERMETIC CERDIP

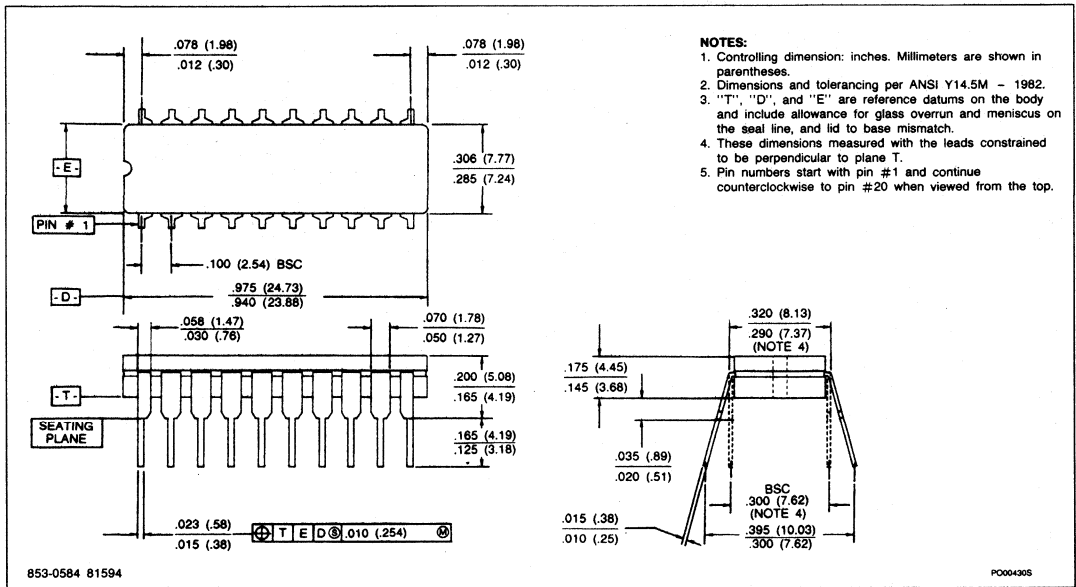



# Package Outlines

## 16-PIN HERMETIC SDIP

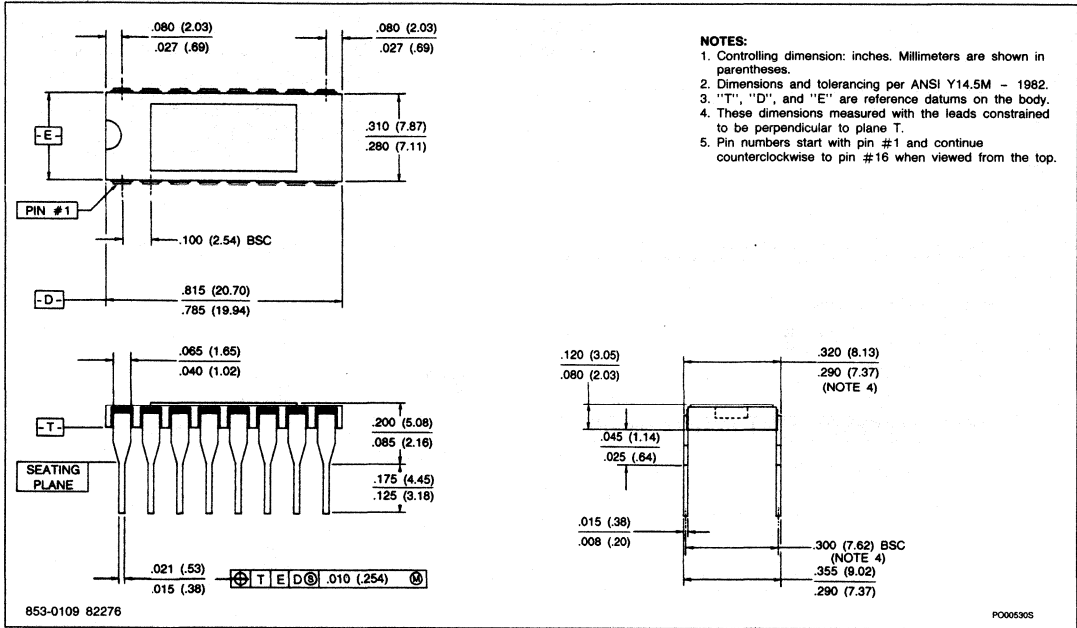

## 24-PIN HERMETIC SDIP

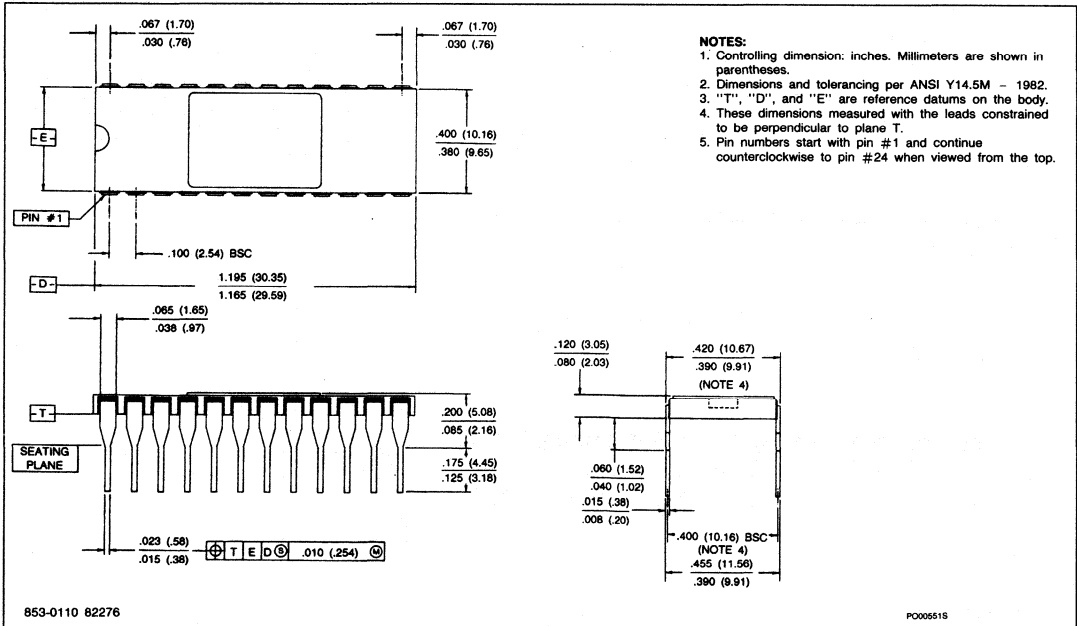

# Package Outlines

## 28-PIN HERMETIC SDIP

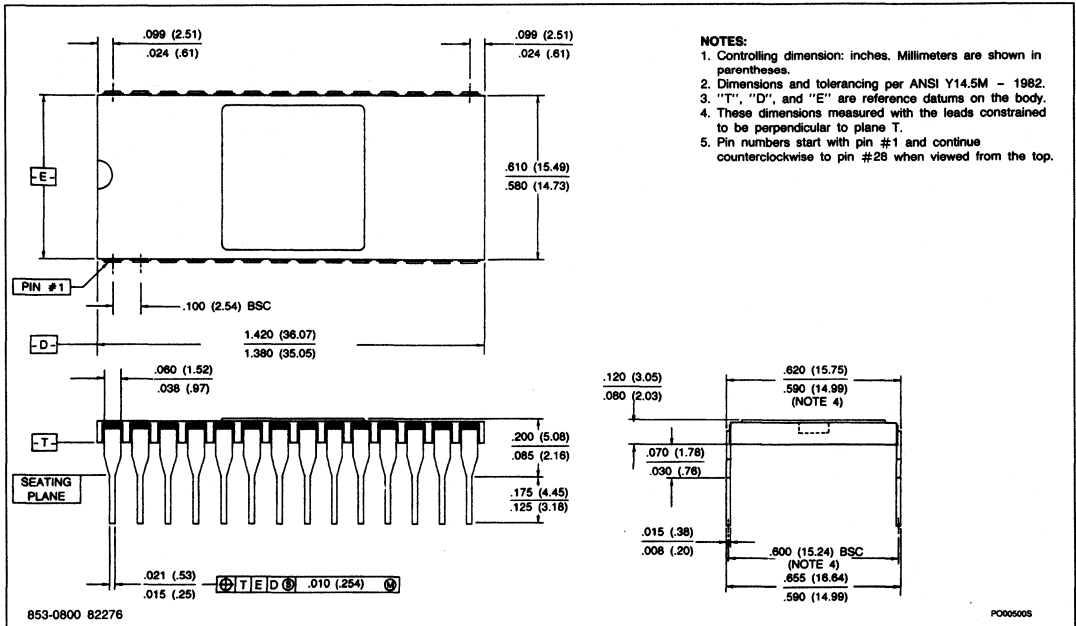

## 40-PIN HERMETIC SDIP

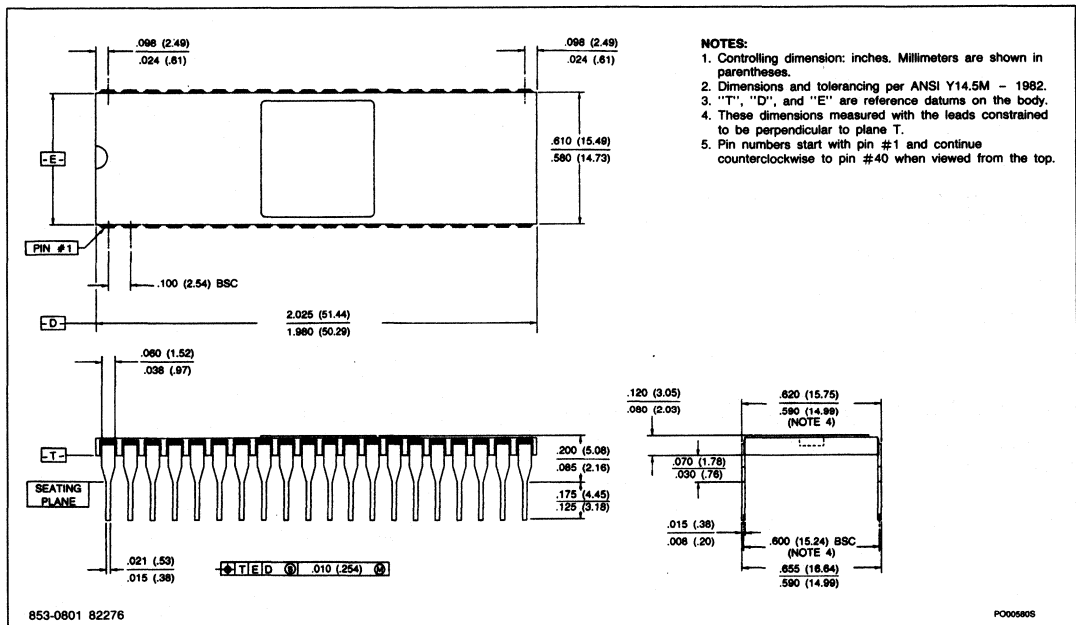

# Package Outlines

## 48-PIN HERMETIC SDIP

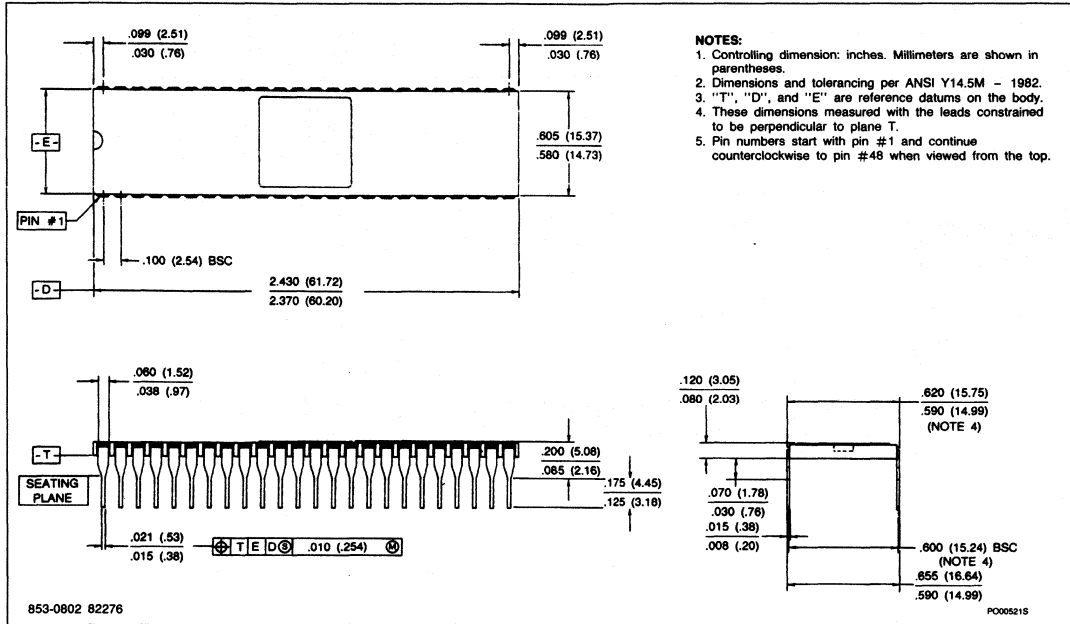

## 50-PIN HERMETIC SDIP

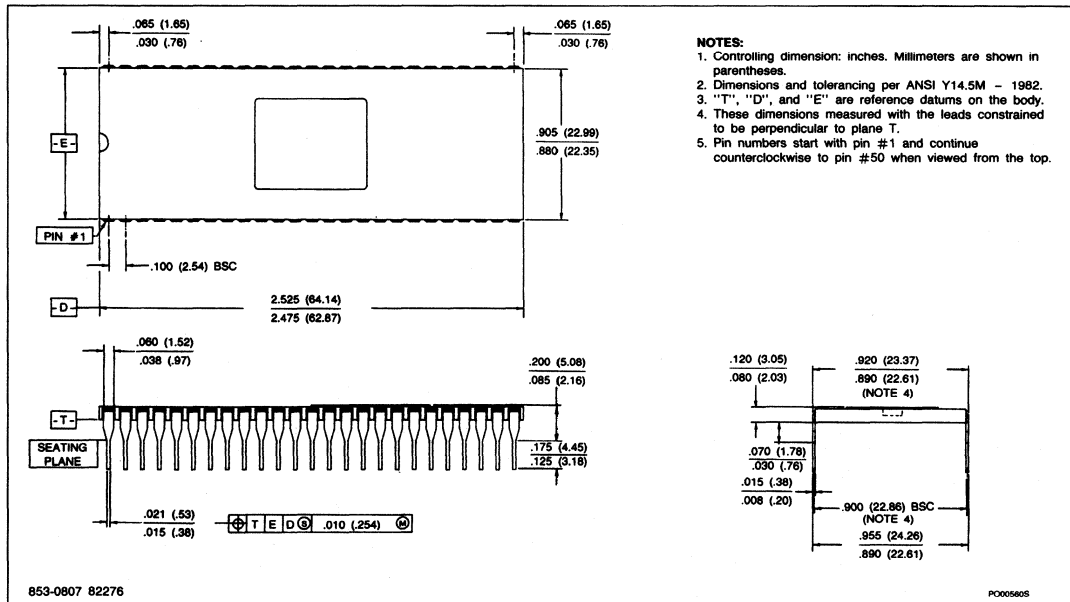

# Package Outlines

## 64-PIN HERMETIC SDIP

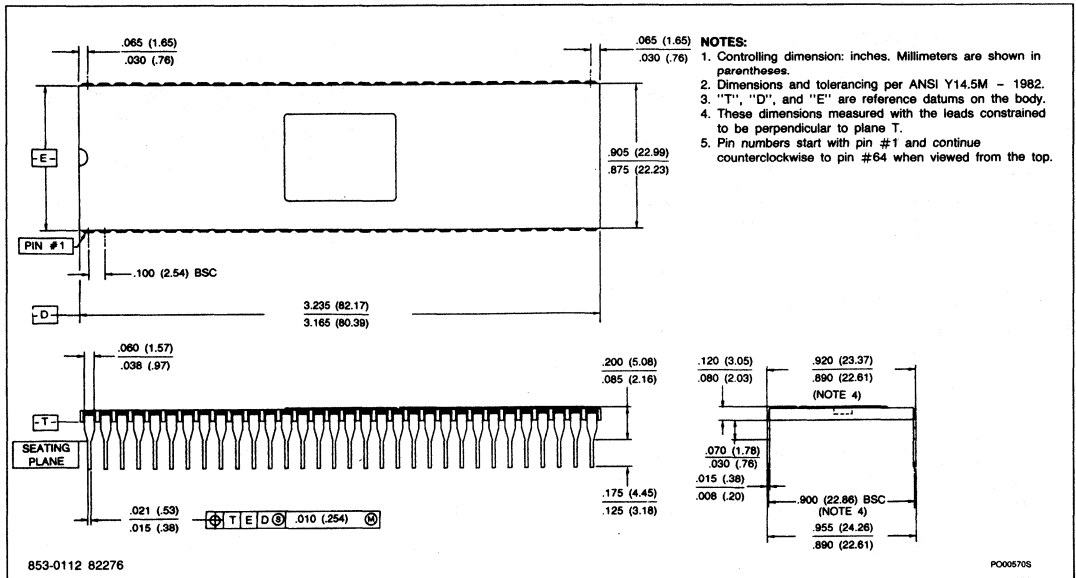

# Package Outlines

## 16-PIN PLASTIC DIP

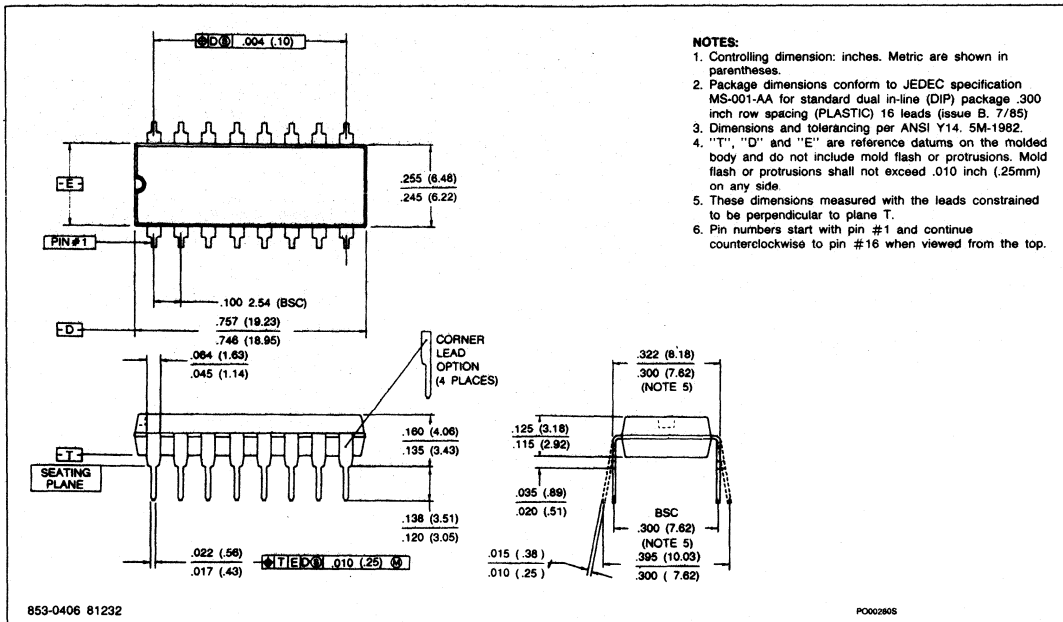

## 20-PIN PLASTIC DIP

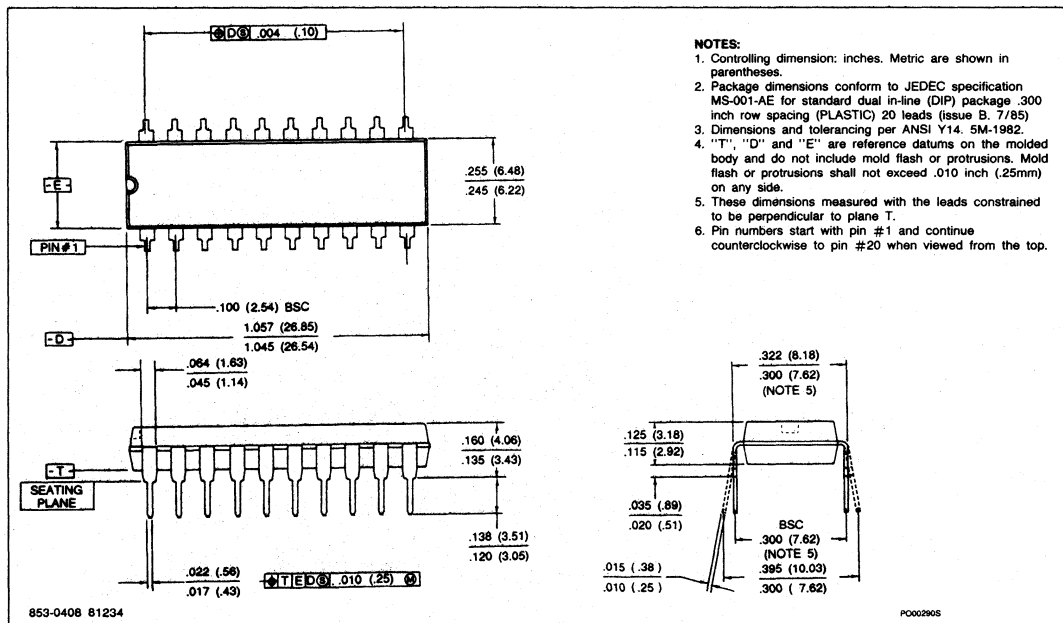

# Package Outlines

## 24-PIN PLASTIC DIP (300mil-wide)

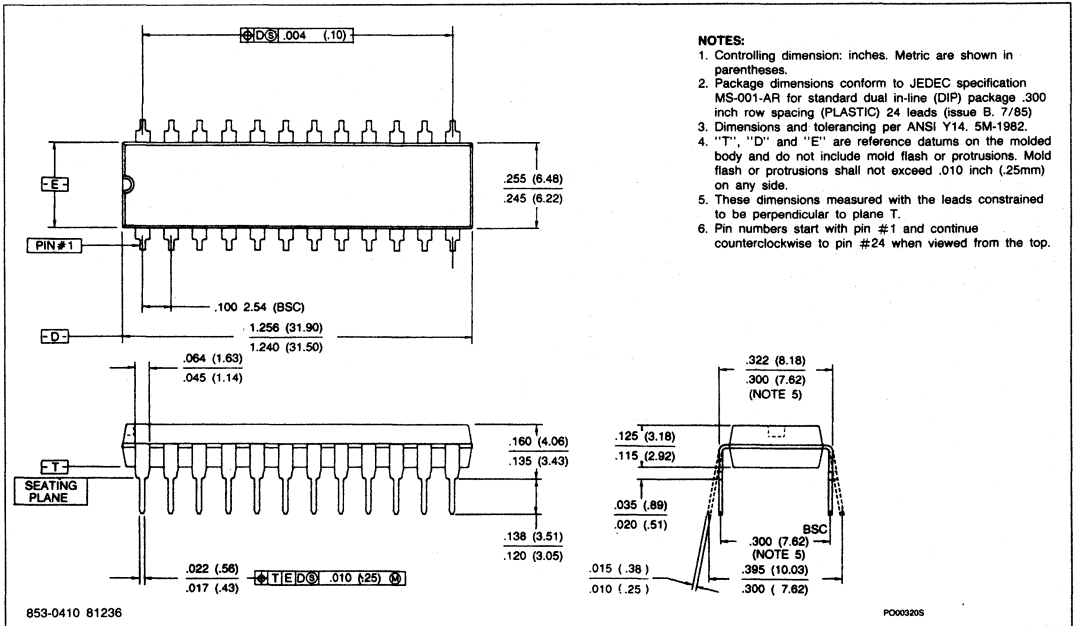

## 24-PIN PLASTIC DIP (400mil-wide)

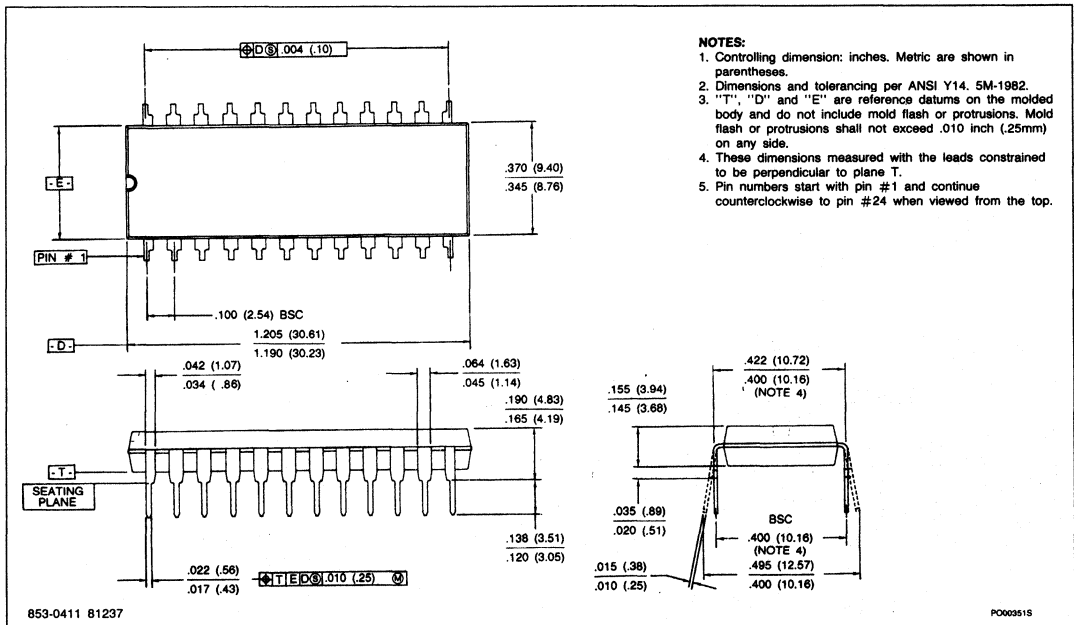

# Package Outlines

## 28-PIN PLASTIC DIP

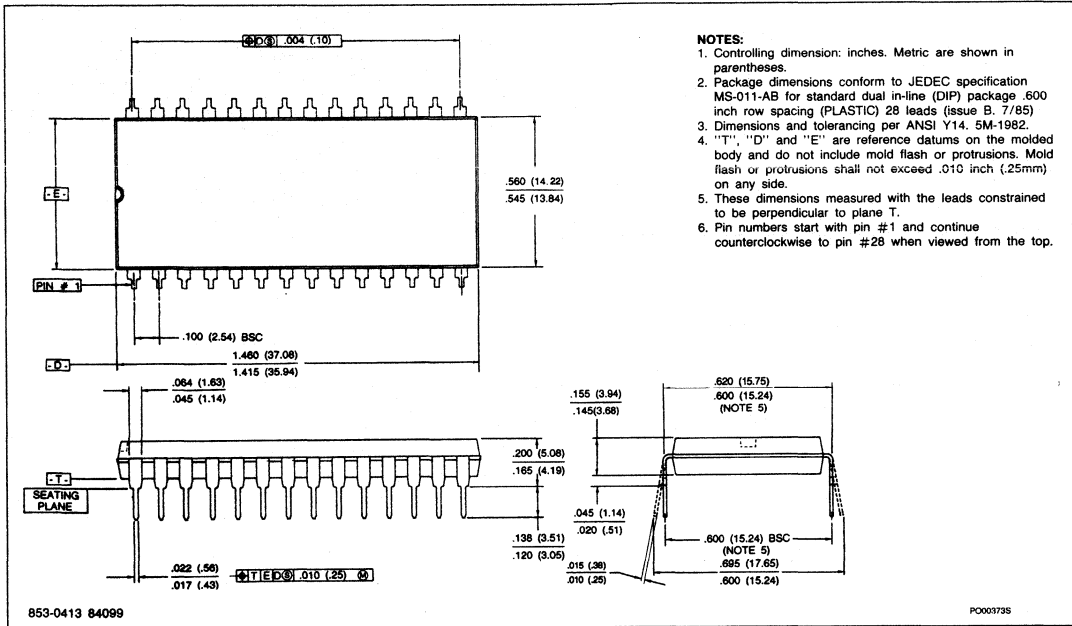

## 40-PIN PLASTIC DIP

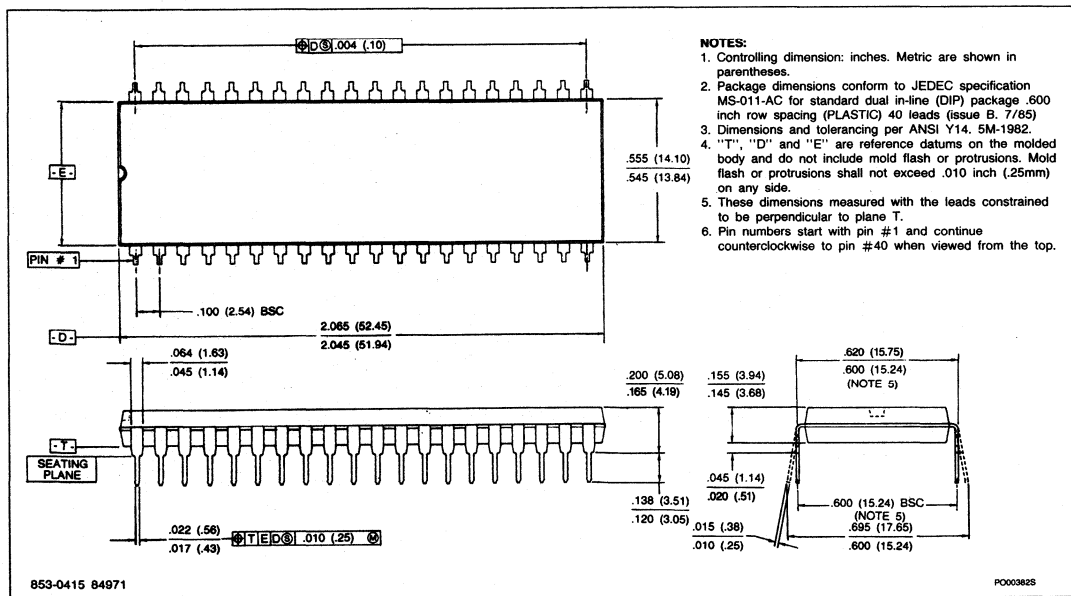

# Package Outlines

## 48-PIN PLASTIC DIP

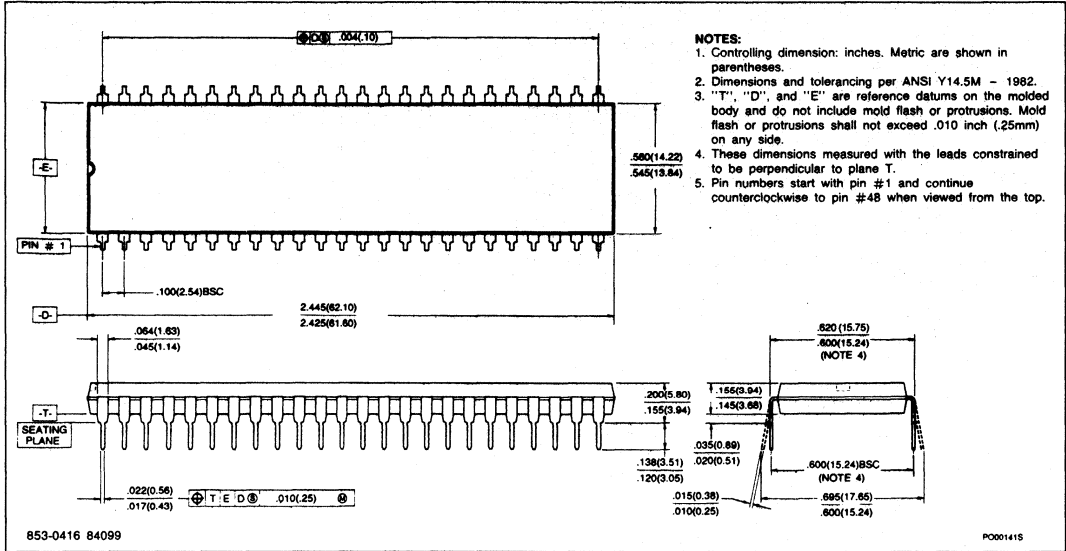

## 50-PIN PLASTIC DIP

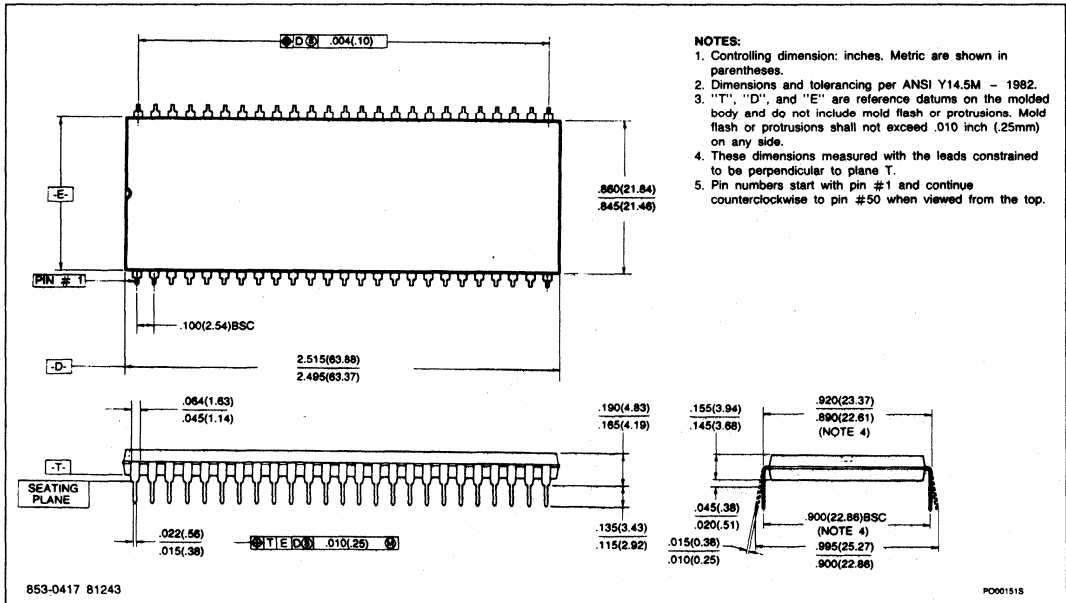



# Package Outlines

## 64-PIN PLASTIC DIP

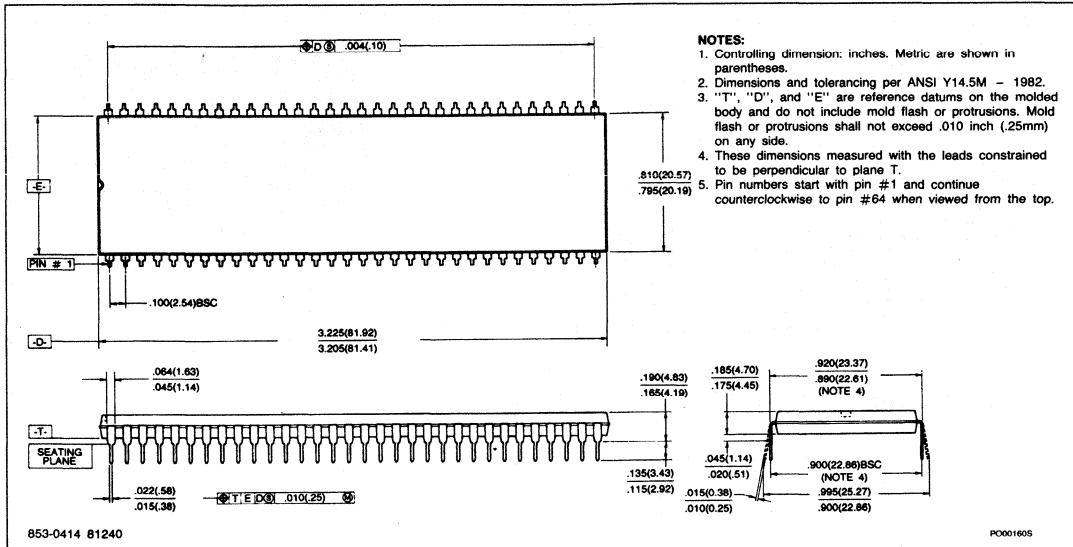

4

# Package Outlines

## 68-PIN GRID ARRAY

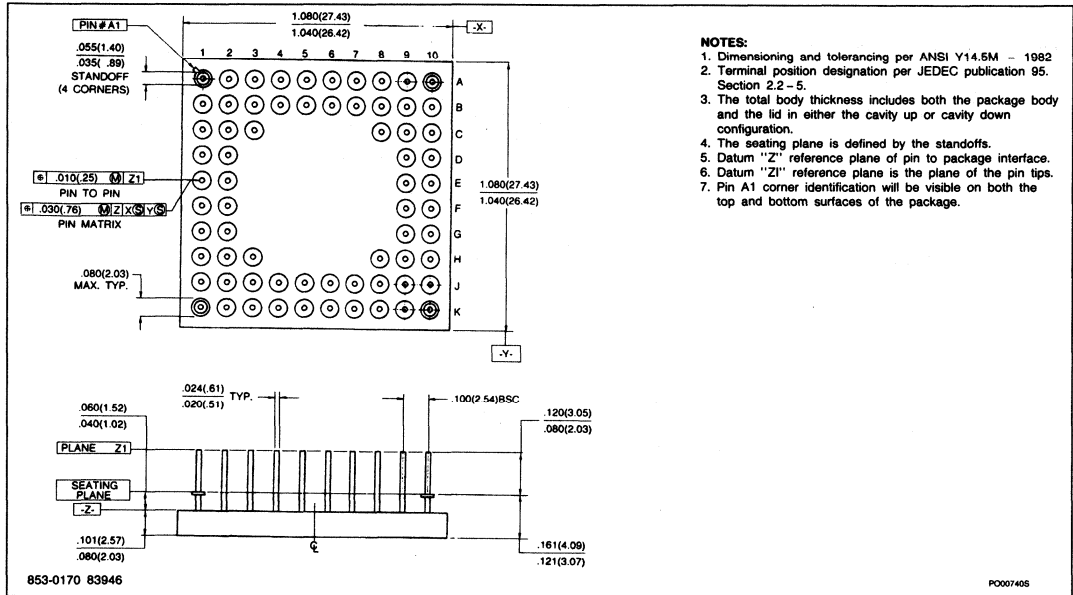

## 120-PIN GRID ARRAY

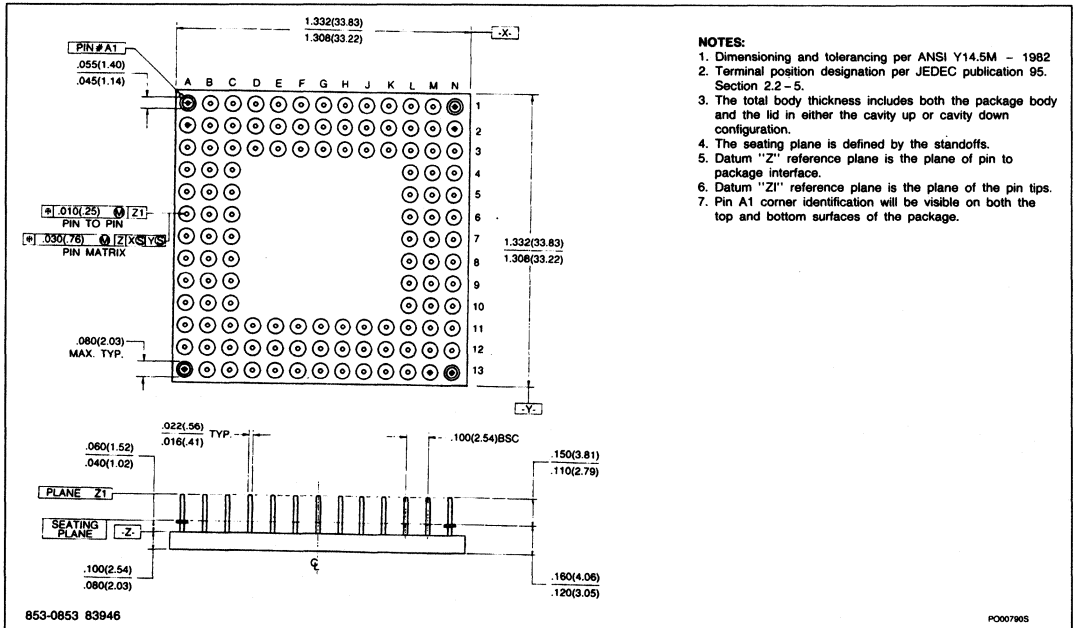

# Section 5 Alphanumeric Index

**Microprocessor Products**

## INDEX

Alphanumeric Index .....	5-3
--------------------------	-----



# Alphanumeric Index

## Microprocessor Products

<b>SCB2673</b>	Video Attributes Controller (VAC) .....	2-132
<b>SCB2675</b>	Color/Monochrome Attributes Controller (CMAC) .....	2-177
<b>SCB2675T</b>	Turbo Color/Monochrome Attributes Controller (Turbo-CMAC) .....	2-188
<b>SCB2677</b>	Video Attributes Controller (VAC) .....	2-199
<b>SCB68154</b>	Interrupt Generator .....	2-471
<b>SCB68155</b>	Interrupt Handler .....	2-482
<b>SCB68171</b>	Very Little Serial Interface Chip (VLSIC) .....	2-499
<b>SCB68172</b>	VMEbus Controller (BUSCON) .....	2-504
<b>SCB68430</b>	Direct Memory Access Interface (DMAI) .....	2-544
<b>SCC2691</b>	Universal Asynchronous Receiver/Transmitter (UART) .....	2-230
<b>SCC2692</b>	Dual Asynchronous Receiver/Transmitter (DUART) .....	2-247
<b>SCC2698</b>	Octal Universal Asynchronous Receiver/Transmitter (Octal UART) .....	2-266
<b>SCC63484</b>	Advanced CRT Controller (ACRTC) .....	2-285
<b>SCC68173</b>	VMSbus Controller (VMSCON) .....	2-530
<b>SCC68692</b>	Dual Asynchronous Receiver/Transmitter (DUART) .....	2-632
<b>SCN2641</b>	Asynchronous Communications Interface .....	2-3
<b>SCN2651</b>	Programmable Communications Interface (PCI) .....	2-16
<b>SCN2652/68652</b>	Multi-Protocol Communications Controller (MPCC) .....	2-32
<b>SCN2653/68653</b>	Polynomial Generator Checker (PGC) .....	2-52
<b>SCN2661/68661</b>	Enhanced Programmable Communications Interface (EPCI) .....	2-70
<b>SCN2671</b>	Programmable Keyboard and Communication Controller (PKCC) .....	2-87
<b>SCN2672</b>	Programmable Video Timing Controller (PVTC) .....	2-109
<b>SCN2674</b>	Advanced Video Display Controller (AVDC) .....	2-145
<b>SCN2681</b>	Dual Asynchronous Receiver/Transmitter (DUART) .....	2-211
<b>SCN68000</b>	16-/32-Bit Microprocessor .....	2-340
<b>SCN68010</b>	16-Bit Virtual Memory Microprocessor .....	2-402
<b>SCN68562</b>	Dual Universal Serial Communications Controller (DUSCC) .....	2-565
<b>SCN68681</b>	Dual Asynchronous Receiver/Transmitter (DUART) .....	2-612



## DATA HANDBOOK SYSTEM





## DATA HANDBOOK SYSTEM

Our Data Handbook System comprises more than 60 books with specifications on electronic components, subassemblies and materials. It is made up of four series of handbooks:

ELECTRON TUBES	BLUE
SEMICONDUCTORS	RED
INTEGRATED CIRCUITS	PURPLE
COMPONENTS AND MATERIALS	GREEN

The contents of each series are listed on pages iv to vii.

The data handbooks contain all pertinent data available at the time of publication, and each is revised and reissued periodically.

When ratings or specifications differ from those published in the preceding edition they are indicated with arrows in the page margin. Where application information is given it is advisory and does not form part of the product specification.

Condensed data on the preferred products of Philips Electronic Components and Materials Division is given in our Preferred Type Range catalogue (issued annually).

Information on current Data Handbooks and on how to obtain a subscription for future issues is available from any of the Organizations listed on the back cover.

Product specialists are at your service and enquiries will be answered promptly.

## ELECTRON TUBES (BLUE SERIES)

The blue series of data handbooks comprises:

- T1**      **Tubes for r.f. heating**
- T2a**     **Transmitting tubes for communications, glass types**
- T2b**     **Transmitting tubes for communications, ceramic types**
- T3**      **Klystrons**
- T4**      **Magnetrons for microwave heating**
- T5**      **Cathode-ray tubes**  
Instrument tubes, monitor and display tubes, C. R. tubes for special applications
- T6**      **Geiger-Müller tubes**
- T8**      **Colour display systems**  
Colour TV picture tubes, colour data graphic display tube assemblies, deflection units
- T9**      **Photo and electron multipliers**
- T10**     **Plumbicon camera tubes and accessories**
- T11**     **Microwave semiconductors and components**
- T12**     **Vidicon and Newvicon camera tubes**
- T13**     **Image intensifiers and infrared detectors**
- T15**     **Dry reed switches**
- T16**     **Monochrome tubes and deflection units**  
Black and white TV picture tubes, monochrome data graphic display tubes, deflection units

## SEMICONDUCTORS (RED SERIES)

The red series of data handbooks comprises:

- S1 Diodes**  
Small-signal silicon diodes, voltage regulator diodes (< 1,5 W), voltage reference diodes, tuner diodes, rectifier diodes
- S2a Power diodes**
- S2b Thyristors and triacs**
- S3 Small-signal transistors**
- S4a Low-frequency power transistors and hybrid modules**
- S4b High-voltage and switching power transistors**
- S5 Field-effect transistors**
- S6 R.F. power transistors and modules**
- S7 Surface mounted semiconductors**
- S8a Light-emitting diodes**
- S8b Devices for optoelectronics**  
Optocouplers, photosensitive diodes and transistors, infrared light-emitting diodes and infrared sensitive devices, laser and fibre-optic components
- S9 Power MOS transistors**
- S10 Wideband transistors and wideband hybrid IC modules**
- S11 Microwave transistors**
- S12 Surface acoustic wave devices**
- S13 Semiconductor sensors**
- S14 Liquid Crystal Displays**

## INTEGRATED CIRCUITS (PURPLE SERIES)

The purple series of handbooks comprises:

IC01	<b>Radio, audio and associated systems</b> Bipolar, MOS	published 1986
IC02a/b	<b>Video and associated systems</b> Bipolar, MOS	published 1986
IC03	<b>Integrated circuits for telephony</b> Bipolar, MOS	published 1986
IC04	<b>HE4000B logic family</b> CMOS	published 1986
IC05N	<b>HE4000B logic family – uncased ICs</b> CMOS	published 1984
IC06N	<b>High-speed CMOS; PC74HC/HCT/HCU</b> Logic family	published 1986
IC08	<b>ECL 10K and 100K logic families</b>	published 1986
IC09N	<b>TTL logic series</b>	published 1986
IC10	<b>Memories</b> MOS, TTL, ECL	new issue 1987
IC11N	<b>Linear LSI</b>	published 1985
Supplement to IC11N	<b>Linear LSI</b>	published 1986
IC12	<b>I<sup>2</sup>C-bus compatible ICs</b>	not yet issued
IC13	<b>Semi-custom</b> Programmable Logic Devices (PLD)	new issue 1987
IC14	<b>Microcontrollers and peripherals</b> Bipolar, MOS	new issue 1987
IC15	<b>FAST TTL logic series</b>	published 1986
IC16	<b>CMOS integrated circuits for clocks and watches</b>	published 1986
IC17	<b>Integrated Services Digital Networks (ISDN)</b>	not yet issued
IC18	<b>Microprocessors and peripherals</b>	new issue 1987

---

## COMPONENTS AND MATERIALS (GREEN SERIES)

The green series of data handbooks comprises:

- C2** Television tuners, coaxial aerial input assemblies
- C3** Loudspeakers
- C4** Ferroxcube potcores, square cores and cross cores
- C5** Ferroxcube for power, audio/video and accelerators
- C6** Synchronous motors and gearboxes
- C7** Variable capacitors
- C8** Variable mains transformers
- C9** Piezoelectric quartz devices
- C11** Varistors, thermistors and sensors
- C12** Potentiometers, encoders and switches
- C13** Fixed resistors
- C14** Electrolytic and solid capacitors
- C15** Ceramic capacitors
- C16** Permanent magnet materials
- C17** Stepping motors and associated electronics
- C18** Direct current motors
- C19** Piezoelectric ceramics
- C20** Wire-wound components for TVs and monitors
- C22** Film capacitors





# Electronic components and materials for professional, industrial and consumer uses from the world-wide Philips Group of Companies

**Argentina:** PHILIPS ARGENTINA S.A., Div. Elcoma, Vedia 3892, 1430 BUENOS AIRES, Tel. (01) 541 - 7141 to 7747.  
**Australia:** PHILIPS INDUSTRIES LTD., Elcoma Division, 11 Waltham Street, ARTARMON, N.S.W. 2064, Tel. (02) 439 3322.  
**Austria:** ÖSTERREICHISCHE PHILIPS INDUSTRIE G.m.b.H., UB Bauelemente, Triester Str. 64, A-1101 WIEN, Tel. (0222) 6291 11-0.  
**Belgium:** N.V. PHILIPS & MBLE ASSOCIATED, 80 Rue Des Deux Gares, B-1070 BRUXELLES, Tel. (02) 525-61-11.  
**Brazil:** CONSTANTA-IBRAPE; (Active Devices): Av. Brigadeiro Faria Lima, 1735-SAO PAULO-SP, Tel. (011) 211-2600,  
(Passive Devices & Materials): Av. Francisco Monteiro, 702 - RIBEIRAO PIRES-SP, Tel. (011) 459-8211.  
**Canada:** PHILIPS ELECTRONICS LTD., Elcoma Division, 601 Milner Ave., SCARBOROUGH, Ontario, M1B 1M8, Tel. (416) 292-5161.  
**Chile:** PHILIPS CHILENA S.A., Av. Santa Maria 0760, SANTIAGO, Tel. (02) 77 38 16.  
**Colombia:** IND. PHILIPS DE COLOMBIA S.A., c/o IPRELENCO LTD., Cra. 21, No. 56-17, BOGOTA, D.E., Tel. (01) 2497624.  
**Denmark:** MINIWATT A/S, Strandlodsvej 2, P.O. Box 1919, DK 2300 COPENHAGEN S, Tel. (01) 54 11 33.  
**Finland:** OY PHILIPS AB, Elcoma Division, Kaivokatu 8, SF-00100 HELSINKI 10, Tel. (90) 1 72 71.  
**France:** RTC-COMPELEC, 130 Avenue Ledru Rollin, F-75540 PARIS 11, Tel. (01) 43 38 80 00.  
**Germany (Fed. Republic):** VALVO, UB Bauelemente der Philips G.m.b.H., Valvo Haus, Burchardstrasse 19, D-2 HAMBURG 1, Tel. (040) 3296-0.  
**Greece:** PHILIPS HELLENIQUE S.A., Elcoma Division, No. 15, 25th March Street, GR 17778 TAVROS, Tel. (01) 48 94 339/48 94 911.  
**Hong Kong:** PHILIPS HONG KONG LTD., Elcoma Div., 15/F Philips Ind. Bldg., 24-28 Kung Yip St., KWAI CHUNG, Tel. (0)-245 21 21.  
**India:** PEICO ELECTRONICS & ELECTRICALS LTD., Elcoma Dept., Band Box Building,  
254-D Dr. Annie Besant Rd., BOMBAY - 400 025, Tel. (022) 4930311/4930590.  
**Indonesia:** P.T. PHILIPS-RALIN ELECTRONICS, Elcoma Div., Setiabudi II Building, 6th Fl., Jalan H.R. Rasuna Said (P.O. Box 223/KBY) Kuningan,  
JAKARTA 12910, Tel. (021) 51 79 95.  
**Ireland:** PHILIPS ELECTRICAL (IRELAND) LTD., Elcoma Division, Newstead, Clonskeagh, DUBLIN 14, Tel. (01) 693355.  
**Italy:** PHILIPS S.p.A., Div. Componenti Elcoma, Piazza IV Novembre 3, I-20124 MILANO, Tel. (02) 6752. 1.  
**Japan:** NIHON PHILIPS CORP., Shuwa Shinagawa Bldg., 26-33 Takanawa 3-chome, Minato-ku, TOKYO (108), Tel. (03) 448-5611.  
(IC Products) SIGNETICS JAPAN LTD., 8-7 Sanbancho Chiyoda-ku, TOKYO 102, Tel. (03) 230-1521.  
**Korea (Republic of):** PHILIPS ELECTRONICS (KOREA) LTD., Elcoma Div., Philips House, 260-199 Itaewon-dong, Yongsan-ku, SEOUL,  
Tel. (02) 794-5011.  
**Malaysia:** PHILIPS MALAYSIA SDN BHD, Elcoma Div., 345 Jalan Gelugor, 11700 PULAU PINANG, Tel. (04) 87 00 44.  
**Mexico:** ELECTRONICA, S.A de C.V., Carr. México-Toluca km. 62.5, TOLUCA, Edo. de México 50140, Tel. Toluca 91 (721) 613-00.  
**Netherlands:** PHILIPS NEDERLAND, Marktgroep Elonco, Postbus 90050, 5600 PB EINDHOVEN, Tel. (040) 78 37 49.  
**New Zealand:** PHILIPS NEW ZEALAND LTD., Elcoma Division, 110 Mt. Eden Road, C.P.O. Box 1041, AUCKLAND, Tel. (09) 605-914.  
**Norway:** NORSK A/S PHILIPS, Electronica Dept., Sandstuveien 70, OSLO 6, Tel. (02) 68 02 00.  
**Pakistan:** PHILIPS ELECTRICAL CO. OF PAKISTAN LTD., Philips Markaz, M.A. Jinnah Rd., KARACHI-3, Tel. (021) 72 57 72.  
**Peru:** CADESA, Av. Alfonso Ugarte 1268, LIMA 5, Tel. (014) 326070.  
**Philippines:** PHILIPS INDUSTRIAL DEV. INC., 2246 Pasong Tamo, P.O. Box 911, Makati Comm. Centre, MAKATI-RIZAL 3116, Tel. (02) 868951 to 59.  
**Portugal:** PHILIPS PORTUGUESA S.A.R.L., Av. Eng. Duarte Pacheco 6, 1009 LISBOA Codex, Tel. (019) 68 31 21.  
**Singapore:** PHILIPS PROJECT DEV. (Singapore) PTE LTD., Elcoma Div., Lorong 1, Toa Payoh, SINGAPORE 1231, Tel. 35 02 000.  
**South Africa:** S.A. PHILIPS (Pty) LTD., EDAC Div., 3rd Floor Rainer House, Upper Railway Rd. & Ove St., New Doornfontein, JOHANNESBURG 2001,  
Tel. (011) 402-4600/07.  
**Spain:** MINIWATT S.A., Balmes 22, BARCELONA 7, Tel. (03) 301 63 12.  
**Sweden:** PHILIPS KOMPONENTER A.B., Lidingsövägen 50, S-11584 STOCKHOLM 27, Tel. (08) 7821000.  
**Switzerland:** PHILIPS A.G., Elcoma Dept., Allmendstrasse 140-142, CH-8027 ZÜRICH, Tel. (01) 488 22 11.  
**Taiwan:** PHILIPS TAIWAN LTD., 150 Tun Hua North Road, P.O. Box 22978, TAIPEI, Taiwan, Tel. (02) 7120500.  
**Thailand:** PHILIPS ELECTRICAL CO. OF THAILAND LTD., 283 Silom Road, P.O. Box 961, BANGKOK, Tel. (02) 233-6330-9.  
**Turkey:** TÜRK PHILIPS TICARET A.S., Elcoma Department, İnönü Cad., No. 78-80, 80090 Ayazpasa ISTANBUL, Tel. (01) 143 59 10.  
**United Kingdom:** MULLARD LTD., Mullard House, Torrington Place, LONDON WC1E 7HD, Tel. (01) 580 6633.  
**United States:** (Active Devices & Materials) AMPEREX SALES CORP., Providence Pike, SLATERSVILLE, R.I. 02876, Tel. (401) 762-9000.  
(Passive & Electromech. Dev.) MEPCO/CENTRALAB, INC., 2001 West Blue Heron Blvd, RIVIERA BEACH, Florida 33404,  
Tel. (305) 881-3200.  
(IC Products) SIGNETICS CORPORATION, 811 East Arques Avenue, SUNNYVALE, CA 94088-3409, Tel. (408) 991-2000.  
**Uruguay:** LUZILECTRON S.A., Avda Uruguay 1287, P.O. Box 907, MONTEVIDEO, Tel. (02) 98 53 95.  
**Venezuela:** IND. VENEZOLANAS PHILIPS S.A., c/o MAGNETICA S.A., Calle 6, Ed. Las Tres Jotas, App. Post. 78117, CARACAS, Tel. (02) 239 39 31.  
**For all other countries apply to:** Philips Electronic Components and Materials Division, International Business Relations, P.O. Box 218,  
5500 MD EINDHOVEN, The Netherlands, Telex 35000 phtcnl

AS54

© Philips Export B.V. 1987

This information is furnished for guidance, and with no guarantee as to its accuracy or completeness; its publication conveys no licence under any patent or other right, nor does the publisher assume liability for any consequence of its use; specifications and availability of goods mentioned in it are subject to change without notice; it is not to be reproduced in any way, in whole or in part, without the written consent of the publisher.